

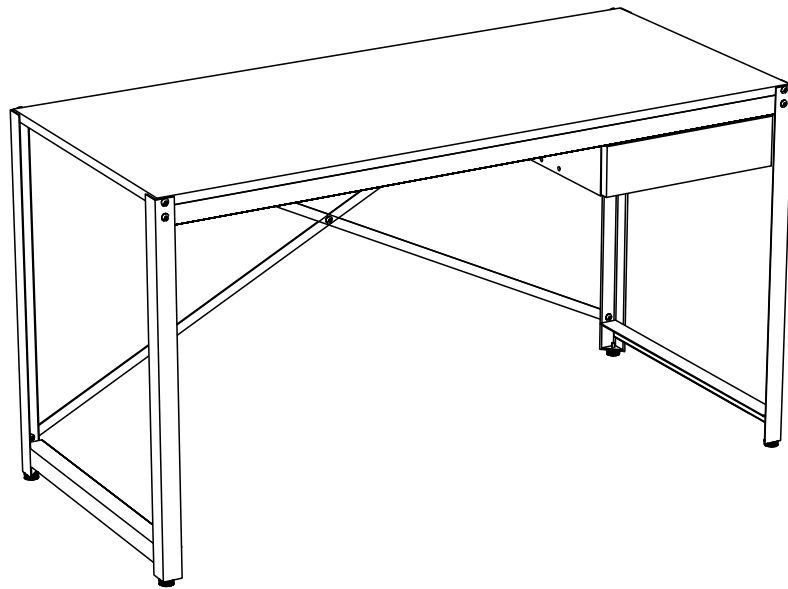













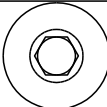

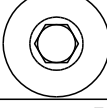
ASSEMBLY INSTRUCTIONS INSTRUCCIONES DE MONTAJE

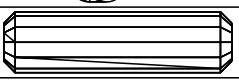

Assemble the furniture as we produce it:
.Arma el mueble como nosotros lo producimos:

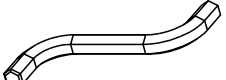
HARDWARE LIST / LISTA DE HERRAJES

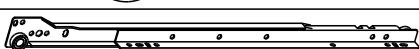
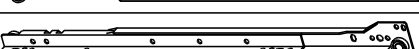
ID	IMAGE REFERENCE IMAGEN REFERENCIA	# OF PIECES CANTIDAD
A	  6,0 x 8mm	04
B	  4,0 x 12mm	04
C	  4,5 x 35mm	22
D	  M8 x 12mm	05
E	  M8 x 25mm	04
F		02
G		02
H	 8 x 30mm	02
I	 Ø18mm	02
J	 1/4" x 30	04
K	 5mm	01
L	 M8	03
M		04
N	 350mm	01
O	 350mm	01

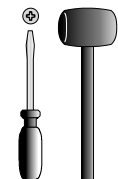
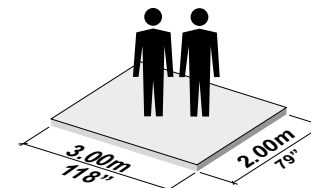

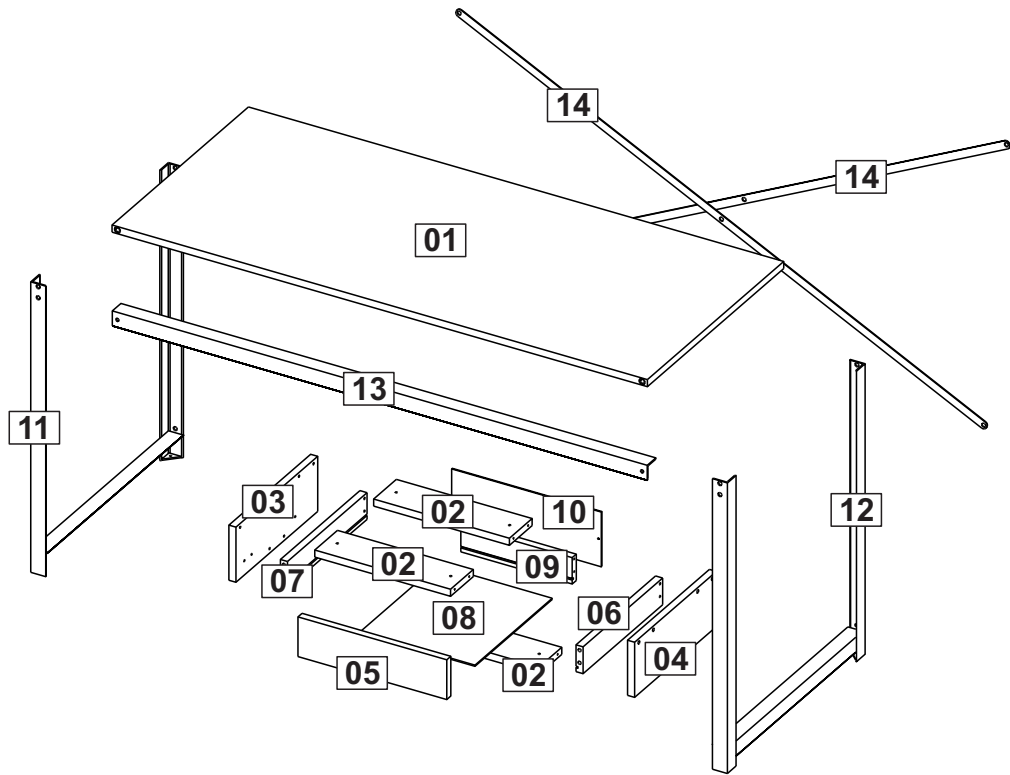

ID	Description / Denominación	Of Pieces cantidad	Dimension (mm) Dimensión (mm)
01	Top/Tapa	01	1360x600x18
02	Crossbar/Travesaño	03	345x100x18
03	Left side/Lateral izquierda	01	140x360x18
04	Right side/Lateral derecha	01	140x360x18
05	Drawer Front/Frente Cajón	01	378x101x18
06	Left Drawer Side/Lateral Izquierda Cajón	01	350x68x18
07	Right Side/Lateral Izquierda Interna	01	350x68x18
08	Drawer Bottom/Fondo Cajón	01	340x292x3
09	Drawer Back/Revés Cajón	01	283x67x18
10	Back/Revés	01	380x139x3
11	Metalic Left Side/Lateral Izquierda Metálica	01	738x606x41
12	Metalic Right Side/Lateral Derecha Metálica	01	738x606x41
13	Stringer/Larguero	01	1359x38x38
14	Reinforcement/Reforzamiento	02	1504x20x2

1 Step
Paso

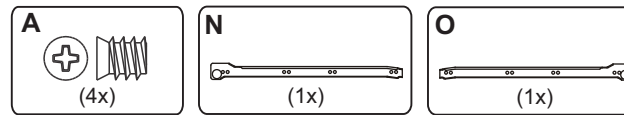
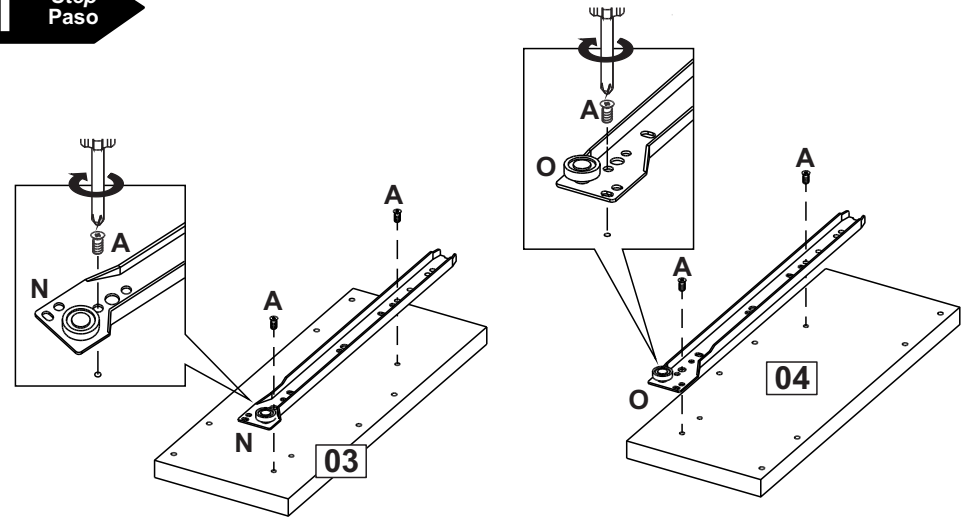

2 Step
Paso

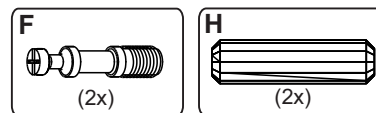
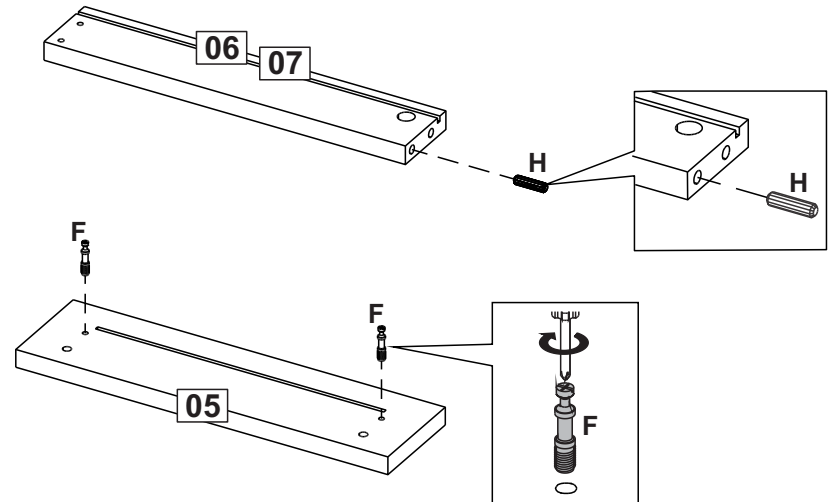

3 Step Paso

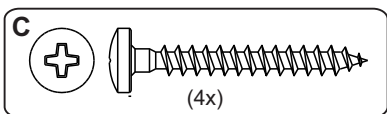
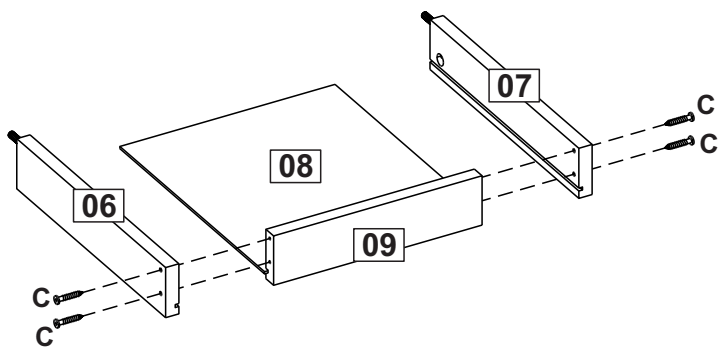

4 Step Paso

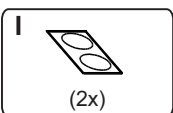
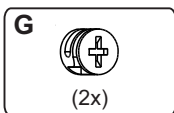
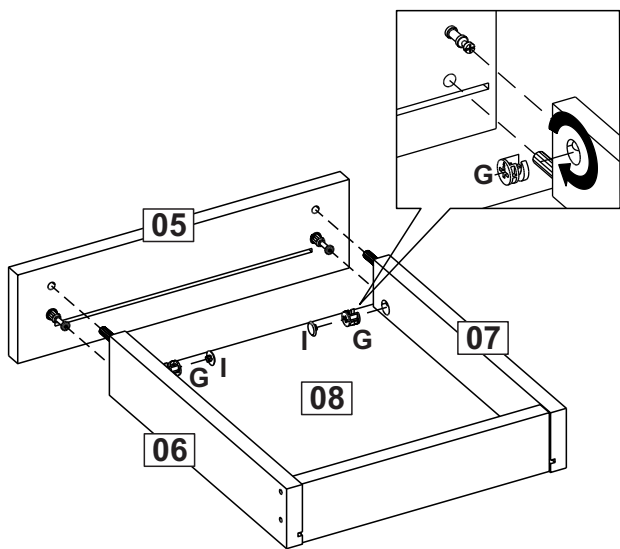

5 Step Paso

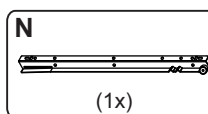
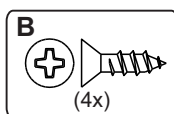
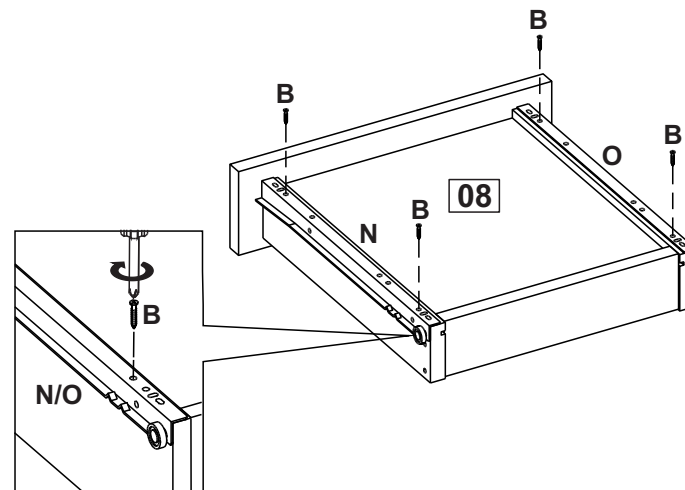

6 Step Paso

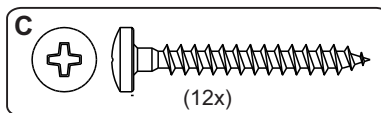
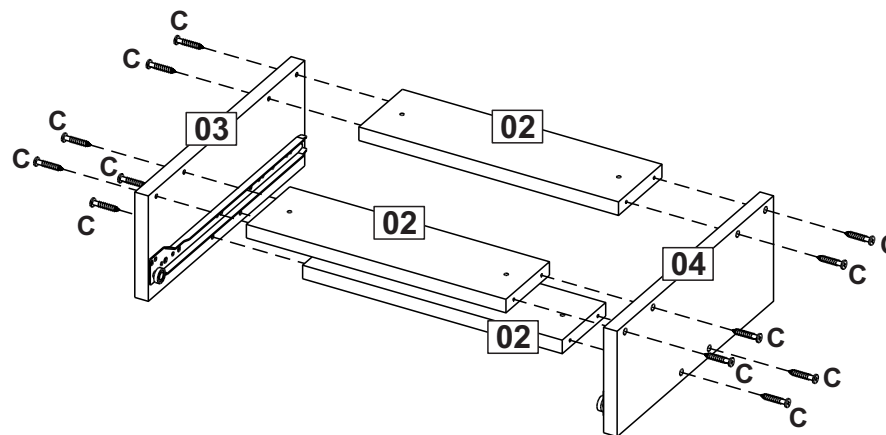

7 Step Paso

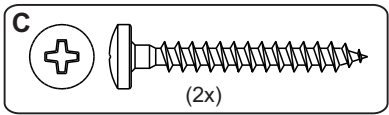
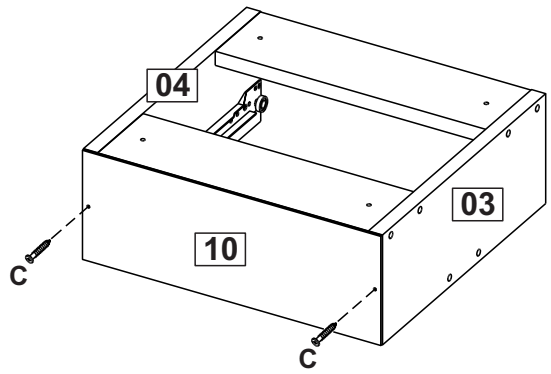

8 Step Paso

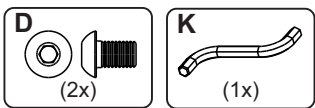
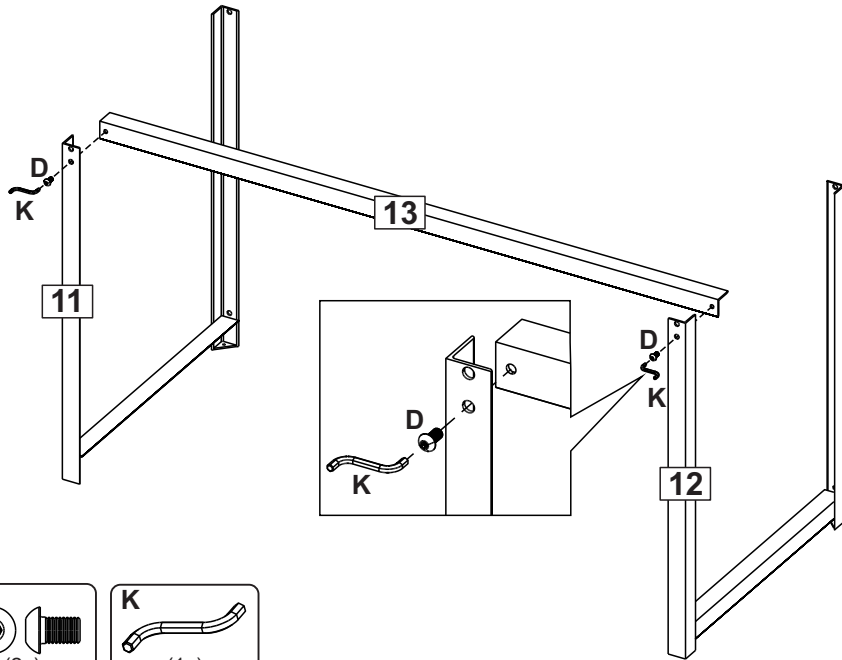

9 Step Paso

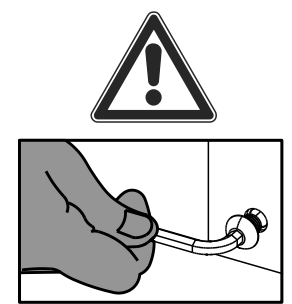
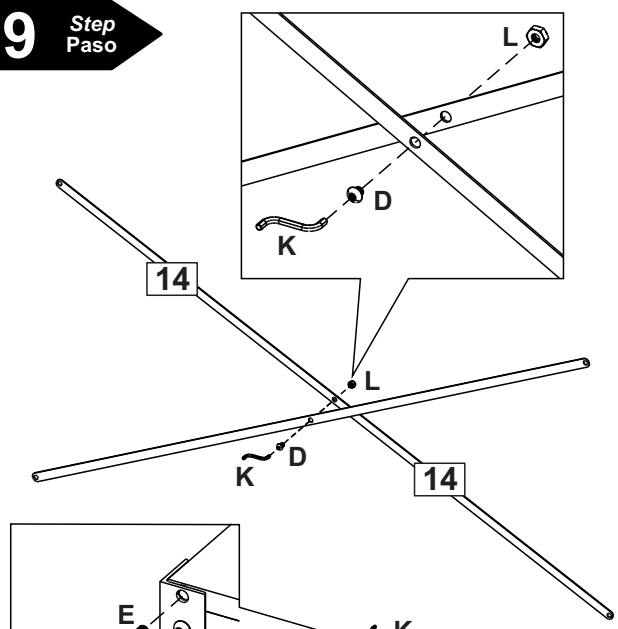

Make hand assembly with the use of key allen to give tightening the screws M8, do not use screwdriver.
 Hacer el montaje a mano con el uso de llave allen para apretar los tornillos M8, no use destornillador.

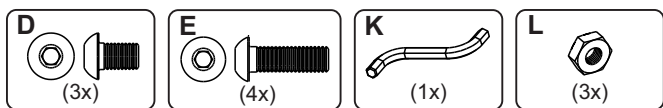
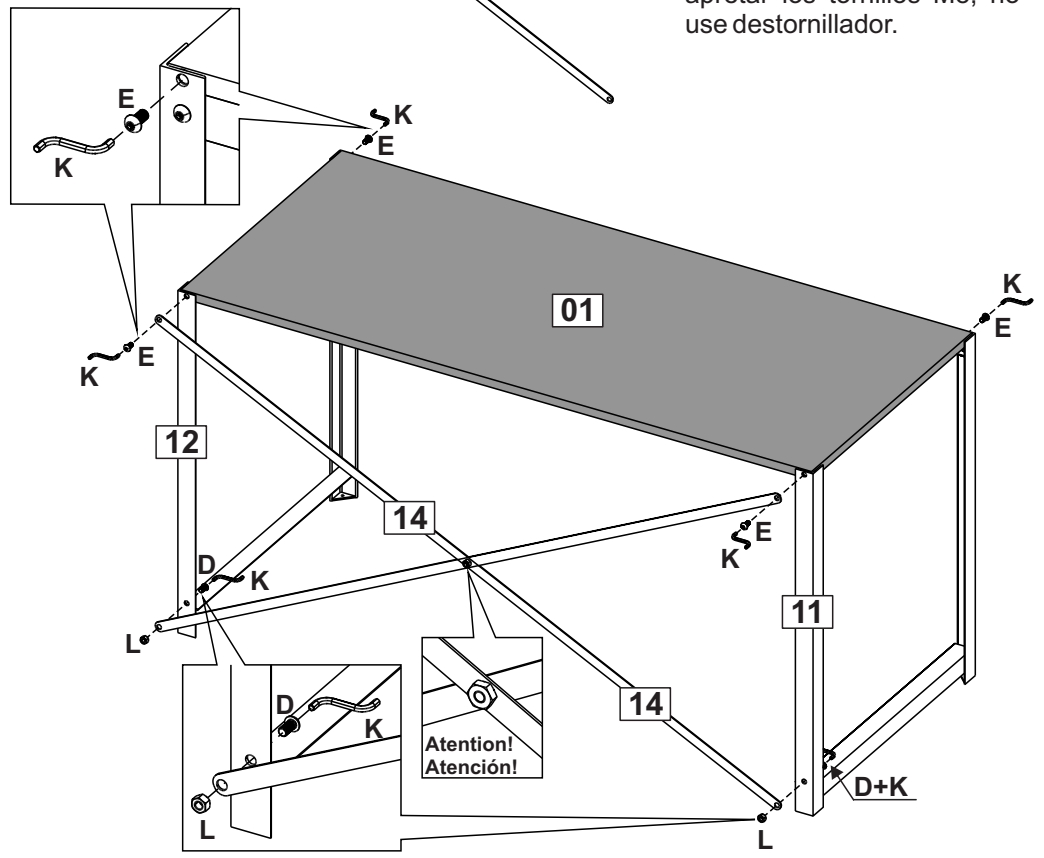

10 Step Paso

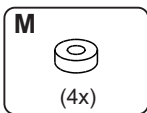
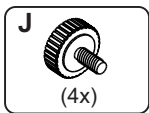
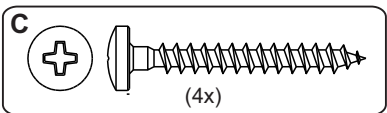
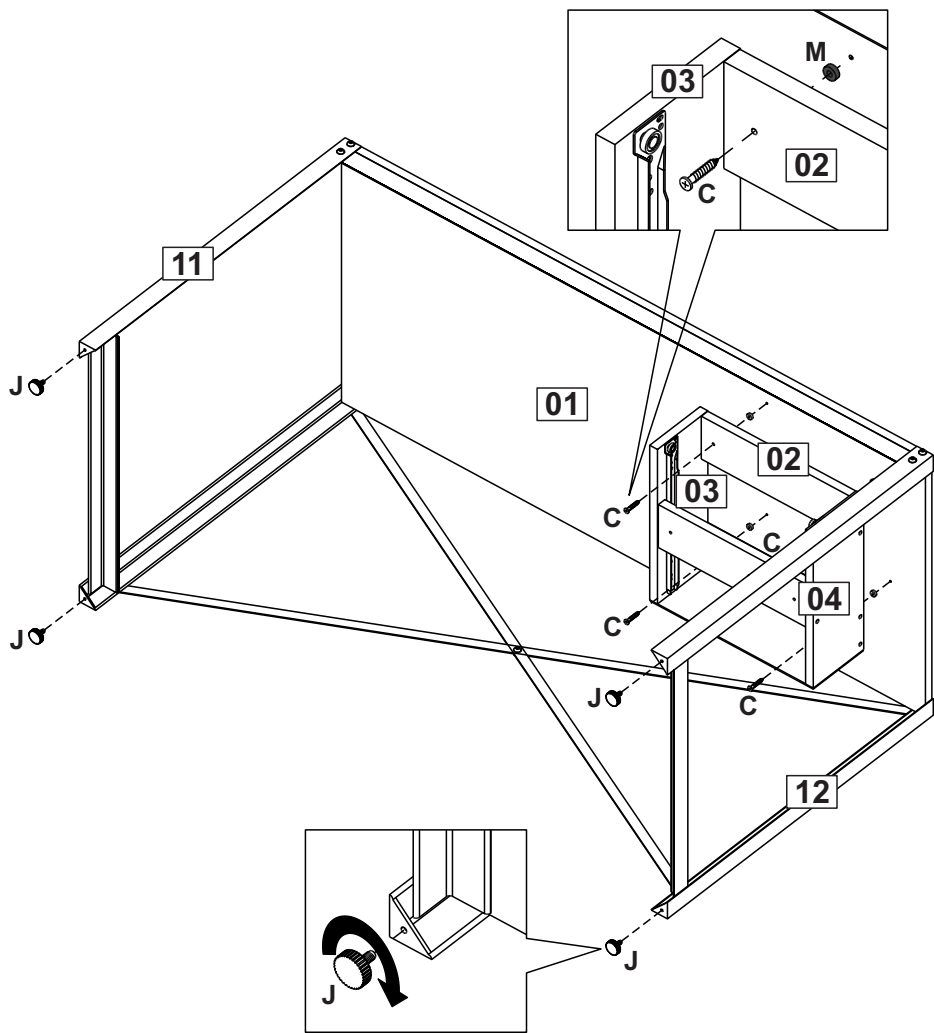

11 Step Paso

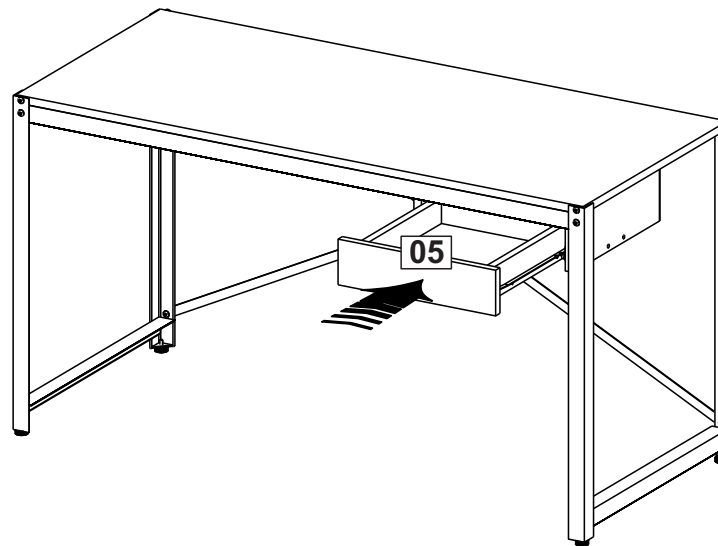

12 Step Paso

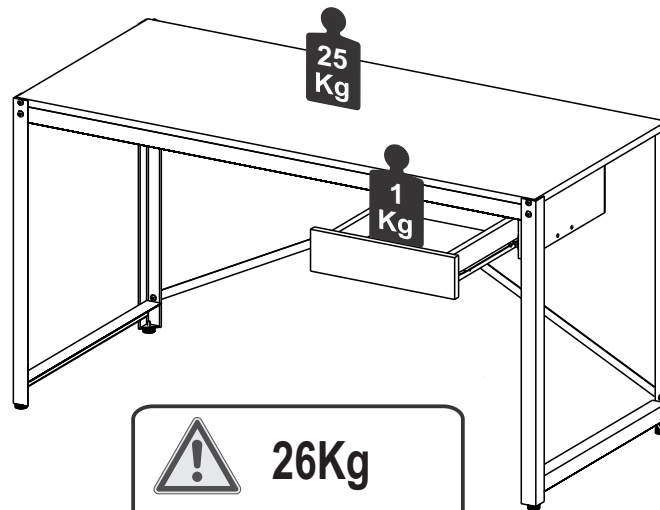

 **26Kg**
MAXIMUM WEIGHT SUPPORTED
PESO MAXIMO SOPORTADO