

Honeywell

48 Can Beverage Cooler User Manual

Read and save these instructions before use

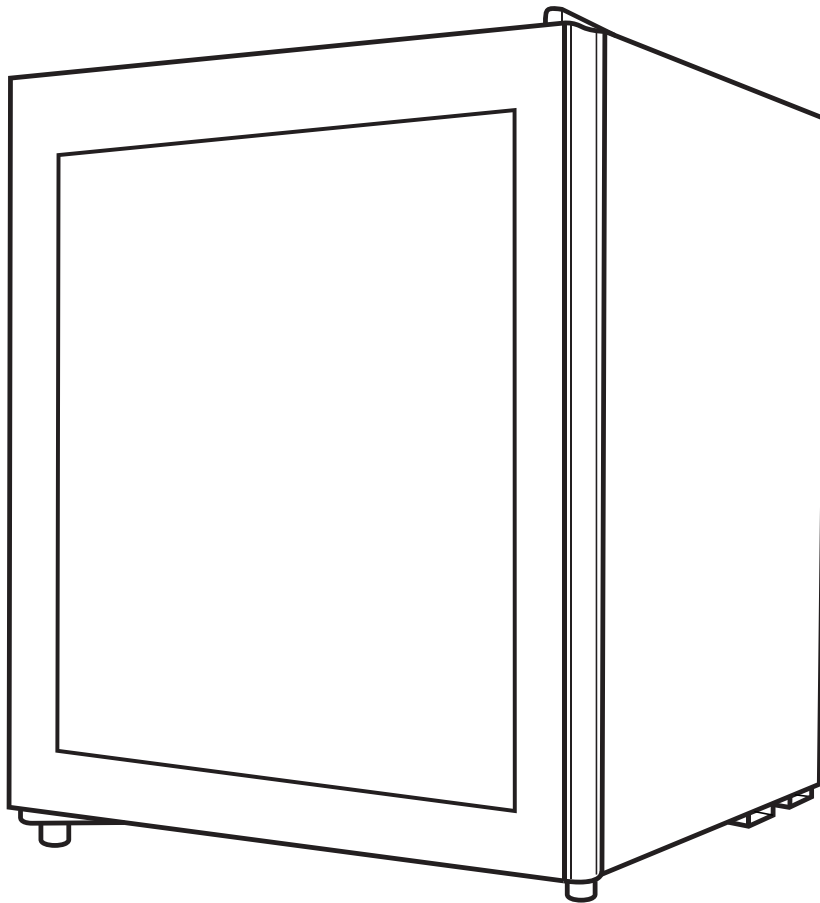

H48BCS

CONTENTS

1 Safety Warnings

1.1 Warning	1
1.2 Electricity related warnings	2
1.3 Related warnings for use	2
1.4 Warnings related to placing items	3
1.5 Warnings for energy	3
1.6 Warnings related to disposal	3

2 Proper Use of Beverage Cooler

2.1 Names of components	4
2.2 Display control	4
2.3 Functions	5-6
2.4 Fast Cool Feature	6
2.5 Placement	7
2.6 Start to Use	7
2.7 The arrangement of bottle	7
2.8 Energy saving tips	7
2.9 Usage of Temperature Zones	7
2.10 Reversing the door swing	8-9

3 Maintenance of Beverage Cooler

3.1 Disconnecting	10
3.2 Stop using	10
3.3 Cleaning	10

4 Troubleshooting

DEAR CUSTOMER:

Thank you for buying this beverage cooler. To ensure that you get the best results from your new beverage cooler, please take time to read through the simple instructions in this booklet. Please ensure that the packing material is disposed of in accordance with the current environmental requirements. When disposing of any beverage cooler equipment please contact your local waste disposal department for advice on safe disposal. This appliance must be only used for its intended purpose.

1 SAFETY WARNINGS

1.1 Warning



WARNING: risk of fire / flammable materials

This appliance is not intended for use by persons (including children) with reduced physical, sensory or mental capabilities unless they have been given permission by a person responsible for their safety. Children should be supervised to ensure that they do not play with the appliance.

If the supply cord is damaged, it must be replaced by the manufacturer, its service agent, or similarly qualified persons in order to avoid a hazard.

The appliance has to be unplugged after use and before carrying out user maintenance.

DO NOT store explosive substances such as aerosol cans in this appliance.

DO NOT use extension cords or ungrounded (two prong) adapters.

WARNING: Keep ventilation openings, in the appliance enclosure or in the built-in structure, clear of obstruction.

WARNING: Do not use mechanical devices or other means to accelerate the defrosting process, other than those recommended by the manufacturer.

WARNING: Do not damage the refrigerant circuit.

WARNING: Do not use electrical appliances inside the food storage compartments of the appliance, unless they are the type recommended by the manufacturer.

WARNING: This appliance uses flammable blowing gas and refrigerant. Please dispose of according to local regulators.

WARNING: When positioning the appliance, ensure the supply cord is not trapped or damaged, and that it is positioned in accordance with the instructions.

WARNING: Do not locate multiple portable socket-outlets or portable power supplies at the rear of the appliance.

DANGER: Risk of child entrapment. Before disposing your old appliance:

- Take off the doors.
- Leave the shelves in place so that children may not easily climb inside.

The appliance must be disconnected from the source of electrical supply before attempting the installation of accessory.

Refrigerant and cyclopentane foaming material used for the appliance are flammable. To prevent damage to the environment or any other harm, when the appliance is scrapped, it shall be kept away from any fire source and be recovered by a recovering company with corresponding qualification.

1.2 Electricity Related Warnings

- Do not pull the power cord when unplugging the appliance. Please firmly grasp the plug and pull out it from the socket directly.
- Do not damage the power cord under any condition, do not use when the power cord is damaged or the plug is worn.
- To prevent a fire, the power plug should be firmly contacted with the socket. Please ensure that the grounding electrode of the power socket is equipped with a reliable grounding line.
- In case of a gas leak, please turn off the valve of the leaking gas and then open the doors and windows. Do not unplug the appliance and other electrical appliances since that spark may cause a fire.
- To ensure safety, it is not recommended to place regulators, rice cookers, microwave ovens and other appliances on the top of the appliance, unless recommended by the manufacturer.

1.3 Related Warnings for Use

- Do not arbitrarily disassemble or reconstruct the appliance, nor damage the refrigerant circuit. Maintenance of the appliance must be conducted by a specialist.
- Damaged power cord must be replaced by the manufacturer, its maintenance department, or related professionals in order to avoid danger.
- To prevent injury, do not to put your hand between the appliance doors and body. Please be gentle when opening the door to avoid falling items.
- To avoid frostbite, do not handle food or containers, especially metal, with wet hands in the freezing chamber when the appliance is running.
- Do not allow children to enter or climb the appliance to prevent entrapment or injury.
- Do not spray, wash, or put the appliance in moist places or places where it can be easily splashed with water to protect the electrical insulation properties.
- Do not place heavy objects on the top of the appliance. Objects may fall when opening the door, and may cause accidental injury.
- Please pull out the plug in case of power failure or cleaning. Do not connect the appliance to power supply within five minutes to prevent damages to the compressor due to successive starts.

1.4 Warnings Related to Placing Items

- Do not put flammable, explosive, volatile, and highly corrosive items in the appliance to prevent damages to the product or fires.
- Do not place flammable items near the appliance to avoid fires.
- This product is a beverage appliance that is suitable for the storage of foods. According to national standards, beverage appliances shall not be used for other purposes, such as storage of blood, drugs or biological products.
- Do not place items such as bottled or sealed container of fluid such as bottled beers and beverages in the appliance.

1.5 Warnings for Energy

- Appliance might not operate consistently when sited for an extended period of time below the range of temperatures that it is designed to withstand.
- Do not exceed the storage time recommended by the food manufacturers for any kind of food and commercially quick-frozen food in appliance.
- A rise in temperature of the frozen food during maintenance or cleaning could shorten the storage life.

1.6 Warnings Related to Disposal

The appliance's refrigerant and cyclopentane foam materials are combustible materials. Discarded appliances should be isolated from fire sources and can not be burned. Please transfer the appliance to qualified professional recycling companies for processing to avoid damages to the environment or other hazards.

Please remove the door of the appliance and shelves to prevent children from entering and playing in the appliance.

Correct Disposal of this product:



This marking indicates that this product should not be disposed with other wastes. To prevent possible harm to the environment or human health from uncontrolled waste disposal, recycle it responsibly to promote the sustainable reuse of material resources. To return your used device, please use the return and collection systems or contact the retailer where the product was purchased. They can take this product for environmentally safe recycling.

2 PROPER USE OF BEVERAGE COOLER

2.1 Names of Components

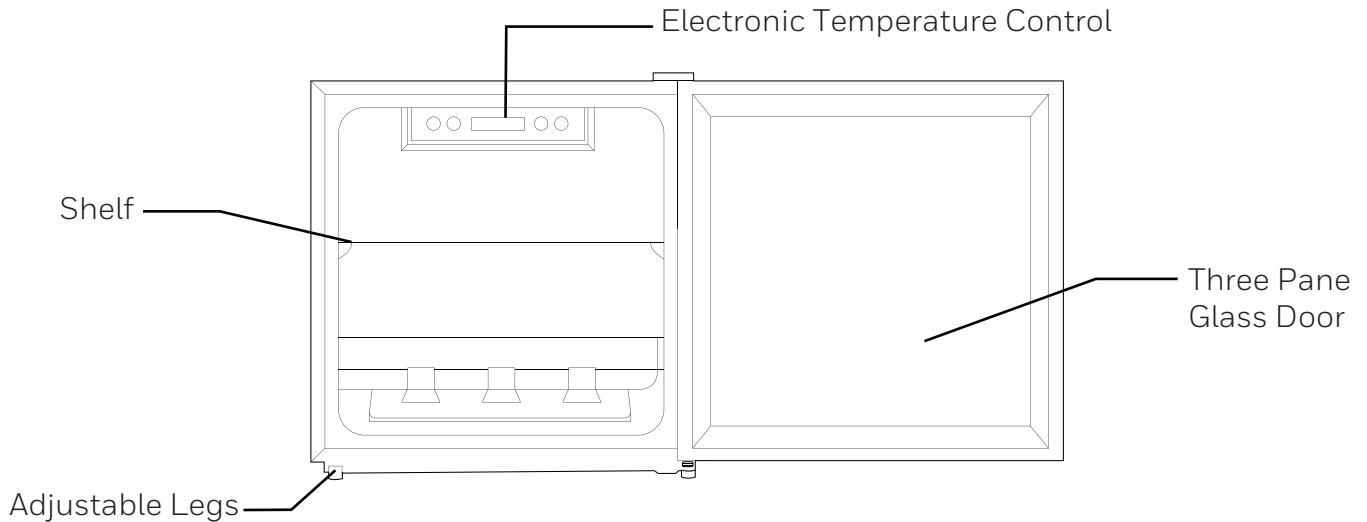

2.2 Display Control

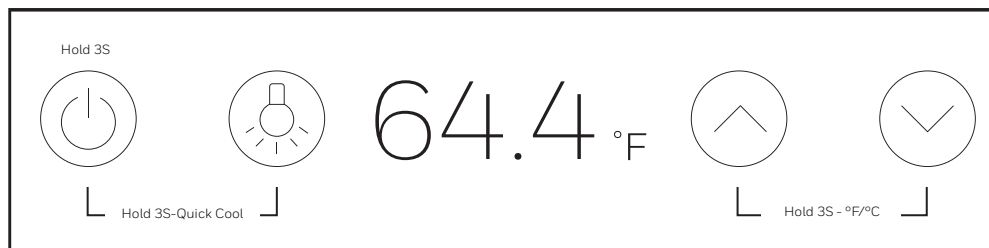

When powering on the cooler for the first time, the display screen will display in full for 3 seconds and the start-up tone will ring, and then the display will enter a normal running state.



Avoid scratching the display panel with sharp objects and keep it away from high magnetic fields and high humidity. Normal settings and operation of the cooler may be affected.

Standby Function

To exit standby state, press the standby button until the buzzer rings. The display screen will then display the set temperature.

To enter the standby state, press the standby button until the buzzer rings. The display screen will turn off.

2.3 Functions

Except for the lighting function, the following functions must be carried out when the display panel is unlocked

Lighting Mode

Press the lighting key until the buzzer rings to turn the internal lamp on or off.

Switching Temperature Units

Press the Temperature-rise key and the Temperature-drop key continuously for 3 seconds to finish the switch of the Celsius temperature and Fahrenheit temperature; the display area will show the setting Fahrenheit temperature or Celsius temperature under the existing mode.

Temperature Setting

Press the temperature-rise key and the temperature will increase 1 °C (or °F). After locking, the cooler will run according to the setting value. Press the temperature-drop key and the temperature will decrease by 1 °C (or °F). After locking, the cooler will run according to the setting value.



- Setting range of the Celsius temperature: 1°C - 10°C.
- Setting range of the Fahrenheit temperature: 33.8°F - 50°F

Memory Function

The cooler has the power-off memory function. If the power supply is reconnected, the cooler will run under the temperature set before power-off.

Error Code

If the following error codes appear on the LED display, please unplug the unit for 24 hours to allow the sensors to completely defrost a restart. If there is still an error when turning the unit back on, please contact the manufacturer.

Error Code	Description
E1	Fault of temperature sensor
E4	Fault of defrosting sensor

Storing too many cans or bottles in the cooler may cause the temperature in the cooler to rise temporarily.

2.4 Fast Cool Feature

- Press and hold the power and light icons together for 3 seconds to activate fast cooling.
- The display will show “FC” to indicate that fast cooling is activated. The unit will cool faster and keep the unit at its cool temperature longer.
- To deactivate fast cooling, press and hold the power and light icons together for 3 seconds again. “FC” will disappear from the display and the regular temperature will appear again.
- Fast Cooling will automatically deactivate when the unit reaches 37.4°F or after 24 hours.

2.5 Placement

- Before using the cooler, remove all packaging materials including bottom cushions, foam pads and tape inside, tear off the protective film on the door and the appliance body.
- The cooler should be placed in a well-ventilated indoor place on ground that is flat and sturdy. (Rotate left or right to adjust the wheel for leveling, if unstable)
- Keep away from heat and avoid direct sunlight. Do not place the appliance in moist or watery places to prevent rust or reduction of insulation.
- Please leave at least 30 cm of space above the appliance, and 10 cm from both sides and backside to facilitate heat dissipation.

2.6 Start to Use

- The cooler must stand upright for half an hour before connecting power when it is first started.
- Clean the interior before using for the first time.
- Do not connect the cooler to electronic energy saving plugs and converters that can convert DC into AC (e.g.: solar energy system, ship grid).
- When the compressor is running, there may be water drops or frost on the backside of the cooler. Wiping out frost or water drops is not needed as the water will be collected into drain tank, then inflow into water disposal pan above the compressor and vaporized.

2.7 The Arrangement of Bottle

Do not let bottles touch the cooler's back in order to maintain good air circulation within the cooler. The bottle number may be different from bottles in different shapes and sizes. Oversized bottles may impact the number of bottles that can be stored inside the beverage cabinet.

2.8 Usage of Temperature Zones Inside the Beverage Cooler

Due to different temperature zones generated due to air circulation in the cooler, the upper area's temperature is higher than the lower area.

2.9 Energy Saving Tips

- The cooler should be placed in a dry and well-ventilated room. The cooler should not be placed in direct sunlight or next to a heat source (such as a radiator, stove, etc.), and a suitable insulation board should be applied if necessary.
- Do not keep the cooler door open for too long.

2.10 Reversing the Door Swing

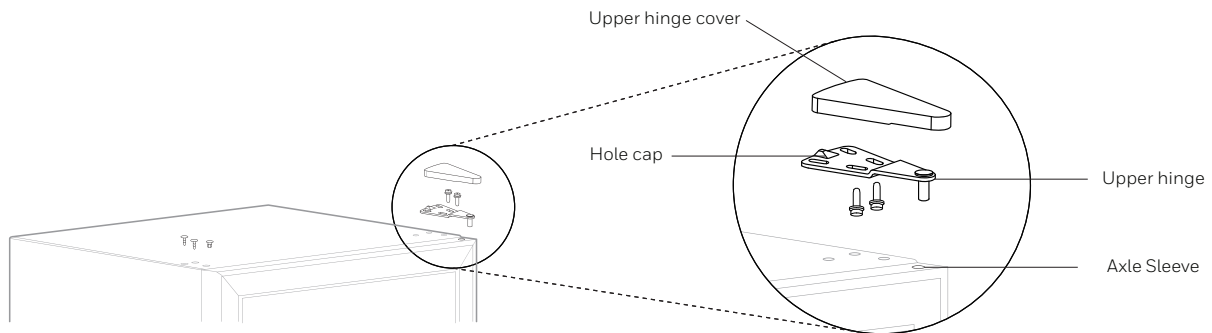

01 Change the installation location of the upper hinge of the beverage cabinet, then the opening direction of the door can be changed at will. Please follow the following instructions for the change of the opening direction of the beverage cabinet's door (for instance: from right-handed door to left-handed door): close the glass door of the beverage cabinet, use a blade to remove the axle sleeve and rivet carefully, loose the mounting cover of the door hinge and three positioning bolts and remove the upper hinge and axle sleeve.

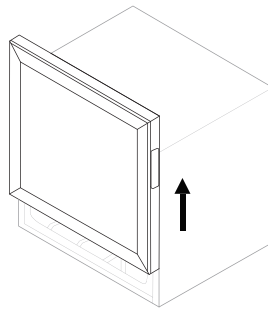

02 Open the door of the beverage cabinet and detach the glass door with tremendous care.

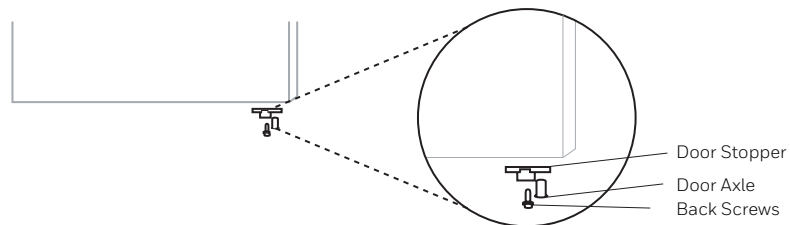

03 Remove the door axle sleeve at the lower part of the glass door, door stopper back screws and door stopper, and fix them to the left side.

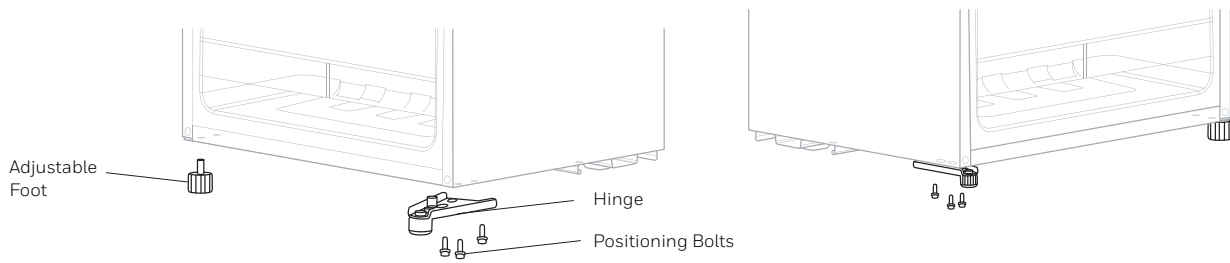

04 Remove the adjustable foot, positioning bolts and lower hinge, then exchange the parts of right and left sides and later use the reverse method to install the adjustable foot and positioning bolts.

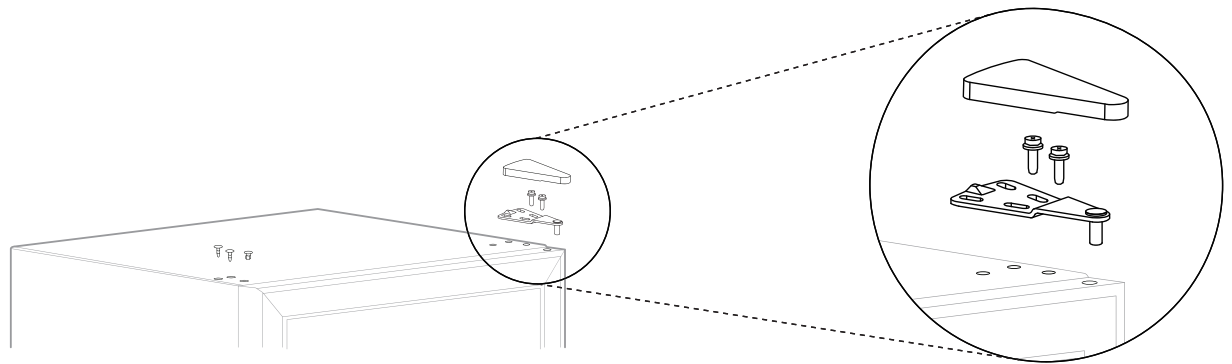

05 Put the glass door on the lower hinge, install the door axle sleeve back and then install the upper hinge. Align the door with the cabinet and check the tightness of gasket.

3 MAINTENANCE OF BEVERAGE COOLER

3.1 Disconnect the cooler

Unplug the power plug to disconnect the cooler.

3.2 Stop using the cooler

- If the cooler is left unused for a long time please:
- Unplug the cooler.
- Clean the cooler.
- Keep the cooler door open.

3.3 Cleaning

- Clean dust behind the cooler and on the ground to improve the cooling effect and energy saving.
- Check the door gasket regularly to make sure there is no debris. Clean the door gasket with a soft cloth dampened with soapy water or diluted detergent.
- Clean the interior of the appliance regularly to avoid odor.
- Please turn off the power before cleaning interior, remove all food, shelves, drawers, etc.
- Use a soft cloth or sponge to clean the inside of the appliance, with two tablespoons of baking soda and a quart of warm water. Then rinse with water and wipe clean. After cleaning, open the door and let it dry naturally before turning on the power.
- For areas that are difficult to clean (such as narrow gaps or corners), it is recommended to wipe them regularly with a soft rag, soft brush, etc. to ensure no contaminants or bacteria accumulate in these areas.
- Do not use soap, detergent, scrub powder, spray cleaner, etc., as these may cause odors in the interior of the appliance or contaminate food.
- Clean the bottle frame, shelves and drawers with a soft cloth dampened with soapy water or diluted detergent. Dry with a soft cloth or dry naturally.
- The wooden wine rack should be cleaned with a dry cloth. The rack should not be directly immersed in liquid to prevent cracking or mold from moisture.
- Wipe the outer surface of the appliance with a soft cloth dampened with soapy water, detergent, etc., and then wipe dry.
- Do not use hard brushes, clean steel balls, wire brushes, abrasives (such as toothpastes), organic solvents (such as alcohol, acetone, banana oil, etc.), boiling water, acid or alkaline items, which may damage the cooler surface and interior. Boiling water and organic solvents such as benzene may deform or damage plastic parts.
- Do not rinse directly with water or other liquids during cleaning to avoid short circuits or damage to the electrical insulation.



Do not use detergent and solvent with sand or acid.



Please unplug the appliance for defrost and cleaning.

4 TROUBLESHOOTING

Inoperation	<p>Ensure the cooler is plugged in and connected to power</p> <p>Check that the voltage is not low</p> <p>Check whether there is a power failure or partial circuits have tripped.</p>
Long-term operation of compressor	<p>Do not overload the coolers</p> <p>Do not open the doors too frequently</p> <p>Note that it is normal that the cooler operates for a longer time in summer when the ambient temperature is higher</p>
Light is out	<p>Check whether the cooler is connected to power supply and whether the indicator light is damaged.</p>
Loud noises	<p>Ensure that the cooler is sitting on a flat and stable surface</p> <p>Ensure that the cooler accessories are properly placed</p>
Cooler enclosure heat condensation	<p>The cooler enclosure may emit heat during operation, especially in summer, caused by the radiation of the condenser; this is normal.</p> <p>Condensation may be detected on the exterior surface and door seals of the appliance when humidity is high; this is normal.</p>
Airflow sound (Buzz / Clatter)	<p>The compressor may cause a buzzing sound when starting up or shutting down.</p> <p>The solenoid valve or electric switch valve may create a clattering sound which is normal and does not affect the operation.</p>



Limited Warranty

Models included are:

H101TFS, H16MRB, H16MRS, H33MRB, H33MRS, H31MRS, H31MRB, H11MFW, H11MFB, H11MFS, H17UFW, H17UFS, H35CFW, H5CFW, H7CFW, H14WCB, H24WCB, H34WCB, H52WCS, H48BCS, H115BCS, H4MFSS, HDS18SS, HDS24SS, HCTDS1W, HCTDS2W, HAC5, HAC5-B, HAC6, HAC6-B, HAC8, HAC8-B, HAC10, HAC10-B, HAC12, HAC12-B, HAC14, HAC12-B, HAC-U8, HAC-U8-B, HAC-U10, HAC-U10-B, HAC-U12-W, HAC-U12-B, H3UFW, H3UFB, H3UFS, HAC-8I, H18TFW, H18TFS

Products listed above are covered by the terms of this Limited Warranty. For purposes of this Limited Warranty, the term “product” means any appliance manufactured for BHRS Group. BHRS Group warrants that it will, at BHRS Group’s option, replace or repair the Purchaser’s BHRS Group product sold in the U.S. or Canada by an authorized retailer if that product is defective due to faulty workmanship or materials, subject to the limitations described in this Limited Warranty. BHRS Group undertakes no responsibility for the quality of the goods except as otherwise provided in this warranty. There are no warranties that extend beyond the description on the face hereof. This Limited Warranty is valid only in connection with the original purchase of new products from authorized retailers and extends from the original purchase date of the original product purchased. This warranty extends only to the original purchaser of the product and lasts for one (1) year from the date of the original purchase or until the original purchaser of the product sells or transfers the product, whichever first occurs. An “original purchaser,” for the purposes of this Limited Warranty, is an individual or entity who purchases the product directly from BHRS Group or an authorized retailer of BHRS Group with the intent to use the product for personal consumer use and commercial or industrial use and not with the intent to resell the product. An “authorized retailer,” for purposes of this Limited Warranty, is an individual or entity authorized by BHRS Group to sell the product directly to original purchasers. An individual or entity that purchases the product from whatever source with the intent to resell the product is an unauthorized reseller (“unauthorized reseller”). For the purpose of this Limited Warranty a “Third Party” would be considered any plumber, maintenance company, or individual hired by the Purchaser.

This Limited Warranty does not apply to used, refurbished, renewed, floor model or “demo” products, or to products sold by unauthorized resellers, including without limitation, unauthorized resellers on third party websites, including, without limitation, Craigslist, eBay, Amazon, etc. Unauthorized resellers are not “original purchasers” for the purpose of this Limited Warranty. If the purchaser is not the original purchaser of this product, the purchaser takes the product “AS IS,” “with all faults” and without warranty. BHRS Group reserves the right to require a valid serial number located on your product to submit a valid claim under this Limited Warranty. Products where the serial number has been removed or evidence showing the removal or attempted removal of the serial number label will not be eligible to make a claim under this Limited Warranty. IF THE PURCHASE OF THIS PRODUCT WAS NOT DIRECTLY FROM BHRS GROUP, PROOF OF PURCHASE WILL BE REQUIRED TO DEMONSTRATE THAT PURCHASER IS THE ORIGINAL PURCHASER AND THE PRODUCT WAS PURCHASED FROM AN AUTHORIZED RETAILER, AND ELIGIBLE TO MAKE A VALID CLAIM UNDER THIS LIMITED WARRANTY.

Your purchase date is established from the date of your sales receipt. BHRS Group may require the purchaser to provide proof of the quality and condition of the appliance if the purchaser makes a claim under this Limited Warranty. BHRS Group reserves the right to invalidate this Limited Warranty if the appliance is determined, in BHRS Group’s reasonable discretion, to be inadequate or if the appliance is found to be in an unsanitary condition. This warranty does not apply if the product was damaged or failed because of accident, improper handling or operation, relocation, abuse, misuse, unauthorized repairs made or attempted, or improper installation or maintenance. Under this Limited Warranty, products are required to be plugged directly into a grounded wall outlet. Plugging a product into an extension cord or surge protector will be considered misuse and will void this Limited Warranty. If damage to the product has occurred during shipping, the damage must be reported to BHRS Group within the first 30 days from the original purchase date to be eligible to make a claim under the Limited Warranty. Shipping damage reported to BHRS Group outside of the first 30 days from the original purchase date will not be eligible for a valid

claim under this Limited Warranty. This warranty does not cover shipping costs for the return of products to BHRS Group for repair or replacement.

To submit a valid claim under this Limited Warranty, troubleshooting the product with a BHRS Group Customer Success Expert is required. If troubleshooting the product is refused by the Purchaser, BHRS Group reserves the right to deny the Limited Warranty Claim. In the event a part is necessary to correct the problem with a Product, BHRS Group will provide the part at no cost to the original purchaser under this Limited Warranty. Replacing parts or attempting to correct an issue with the Product is required prior to submitting a claim for a replacement product under this Limited Warranty. Instructions for troubleshooting a Product or replacing a part will be provided by BHRS Group. Troubleshooting, repairs, part replacement, installation, and proper maintenance are the responsibility of the Purchaser. Instructions for proper installation and maintenance will be provided in the user manual.

Installation, maintenance, or repairs of the Product is the responsibility of the Purchaser. The Purchaser reserves the right to use a Third Party for installation, maintenance, and repair at their own risk. BHRS Group is not responsible for any additional cost incurred for installation, maintenance, or repair of the Product including but not limited to additional material needed for installation or the cost of a Third Party. Damage or failure of the Product due to improper installation, maintenance, or repair caused by a Third Party or the Purchaser is not the responsibility of BHRS Group and will not be covered under this Limited Warranty. Instructions for proper installation and maintenance will be provided in the user manual.

ANY AND ALL WARRANTIES, EXPRESSED OR IMPLIED (INCLUDING, WITHOUT LIMITATION, ANY IMPLIED WARRANTY OF MERCHANTABILITY), LAST ONE YEAR FROM THE DATE OF ORIGINAL PURCHASE OR UNTIL THE ORIGINAL PURCHASER OF THE PRODUCT SELLS OR TRANSFERS THE PRODUCT, WHICHEVER FIRST OCCURS. IN NO EVENT SHALL BHRS GROUP'S LIABILITY UNDER ANY EXPRESS OR IMPLIED WARRANTY INCLUDE (I) INCIDENTAL OR CONSEQUENTIAL DAMAGES FROM ANY CAUSE WHATSOEVER, INCLUDING BUT NOT LIMITED TO ELECTRICAL OR WATER DAMAGE, OR (II) REPLACEMENT OR REPAIR OF ANY HOUSE FUSES, CIRCUIT BREAKERS OR RECEPTACLES. NOTWITHSTANDING ANYTHING TO THE CONTRARY, IN NO EVENT SHALL BHRS GROUP'S LIABILITY UNDER ANY EXPRESS OR IMPLIED WARRANTY EXCEED THE PURCHASE PRICE OF THE PRODUCT AND ANY SUCH LIABILITY SHALL TERMINATE UPON THE EXPIRATION OF THE WARRANTY PERIOD.

Except as otherwise provided, BHRS Group will not charge Original Purchaser to repair or replace the purchaser's Product if it is deemed defective during the length of this Limited Warranty, but any transportation costs associated with repairs or replacements are Purchaser's responsibility. No new warranty is provided with a replacement product. The warranty for the replacement product runs from the date of the original purchase of the original product. In the event that repair is necessary, such repair will be at no charge to the Purchaser except for transportation costs associated with such repair or replacement of a product in compliance with the terms of this Limited Warranty.

In the event, a warranty claim is filed and a warranty replacement is deemed necessary, the purchaser will be required to surrender the original product to BHRS Group at the time of replacement. Some states and provinces do not allow limitations on how long an implied warranty lasts or the exclusion or limitation of incidental or consequential damages, so these exclusions or limitations may not apply to you. This warranty gives you specific legal rights. You may also have other rights which vary from state to state and province to province.

If you want to return or replace the product, please contact the store where it was purchased (remember to bring the purchase invoice). If your product needs repair, please contact us via email or phone.

BHRS Group, LLC

585 Prospect St.
Lakewood, NJ 08701

Customer Service Tel: 1-888-604-0295
Customer Service Email: support@honeywellcoolingappliances.com
Website: honeywellcoolingappliances.com

©2023 BHRS Group, LLC. All Rights Reserved.

The Honeywell Trademark is used under license from Honeywell International Inc. Honeywell International Inc. makes no representations or warranties with respect to this product. This product is manufactured by BHRS Group, LLC.

MADE IN CHINA

Honeywell