



furnishing better
lives together[®]





WWW.JOFRAN.COM

ASSEMBLY INSTRUCTIONS & PARTS IDENTIFICATION

MODEL # 2546-66T/B

WESTPORT NAVY 48" ROUND/OVAL TOP

Thank you for purchasing this quality product. Be sure to check all packing material carefully for small parts that may have come loose inside the carton during shipment.

Hardware kit (2546-66P01)			
No		Description	Q'Ty
A		Flat Washer Ø8.2	12 pcs
B		Lock Washer Ø8.2	12 pcs
C		Nut M7.9 x 0.794	12 pcs
D		Key Wrench	1 pc
E		Allen Key	1 pc

Key Parts			
No	Code	Description	Q'Ty
1	NOT A PART	Table Top	1 pc
2	2546-66TP29	Mounting Plate	1 pc
3	NOT A PART	Pedestal	1 pc
4	2546-66BP14	Base Legs	4 pcs
5	2546-66P01F	Floor Glide	4 pcs
6	2546-66TP01A	Apron Spacer	4 pcs
7	2546-66P13L	Extension Lock	4 pcs

**TWO PERSONS ARE REQUIRED
TO SET UP THE TABLE
DO NOT USE POWER TOOLS**

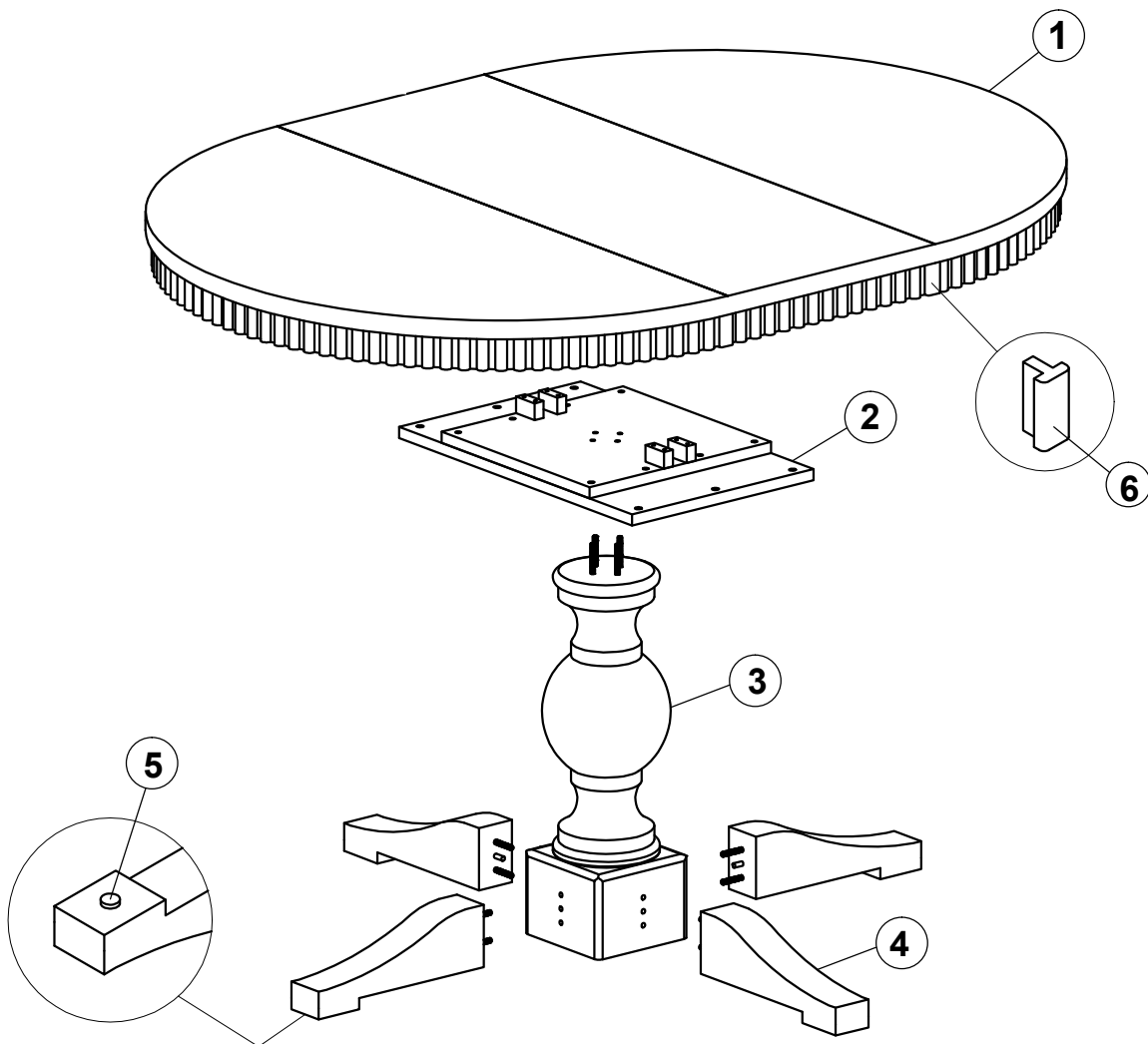



furnishing better
lives together[®]

WWW.JOFRAN.COM

ASSEMBLY INSTRUCTIONS & PARTS IDENTIFICATION

MODEL # 2546-66T/B

WESTPORT NAVY 48" ROUND/OVAL TOP

Thank you for purchasing this quality product. Be sure to check all packing material carefully for small parts that may have come loose inside the carton during shipment.

STEP 1

- Carefully lay the Table Top on a smooth, flat surface to prevent scratches.
- Remove the Mounting Plate from Table Top using the Allen Key (E) provided.

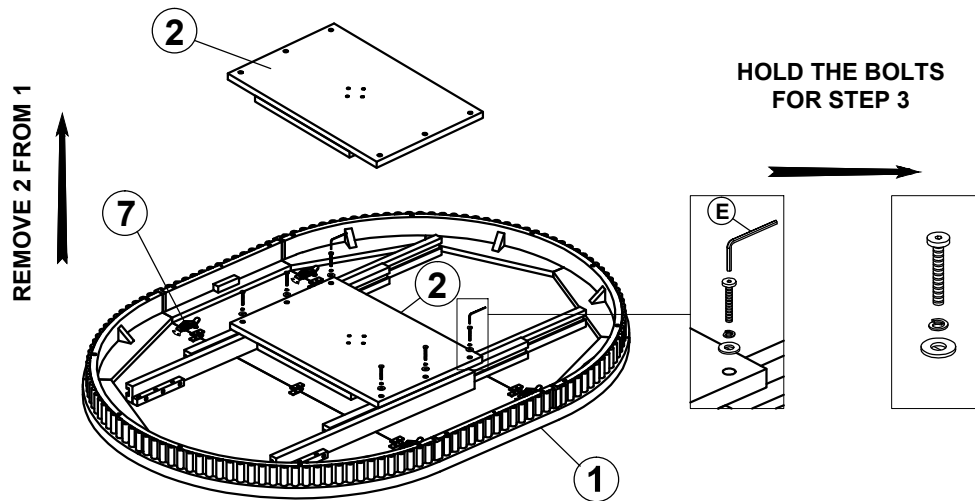

STEP 2

- Attach the Mounting Plate to the top of the Pedestal using the Nut, Lock Washer, Flat Washer, and the Key Wrench (D) provided. (See Detail A)
- Make sure all nuts are securely tightened.

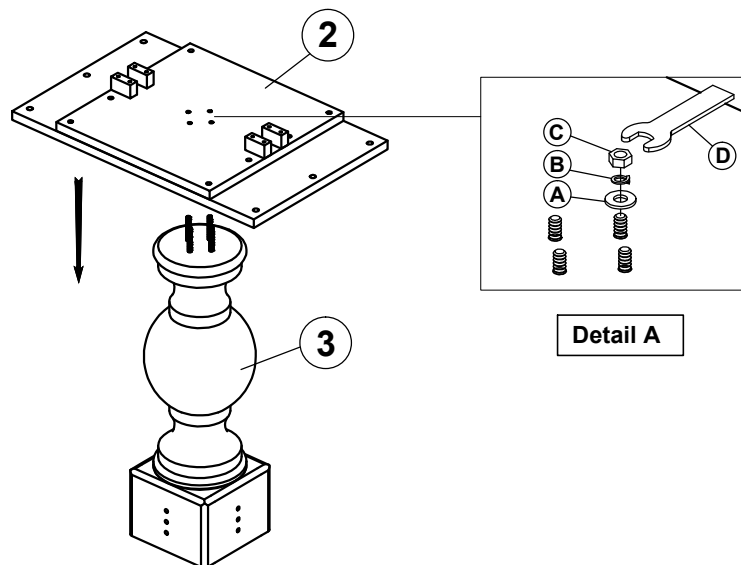



furnishing better
lives together[®]

WWW.JOFRAN.COM

ASSEMBLY INSTRUCTIONS & PARTS IDENTIFICATION

MODEL # 2546-66T/B

WESTPORT NAVY 48" ROUND/OVAL TOP

Thank you for purchasing this quality product. Be sure to check all packing material carefully for small parts that may have come loose inside the carton during shipment.

STEP 3

- Attach the Mounting Plate to the Table Top using the Bolts, Lock Washers, and Flat Washers removed in Step 1, with the Allen Key (E) provided. (See Detail B)
- Make sure all bolts are securely tightened.

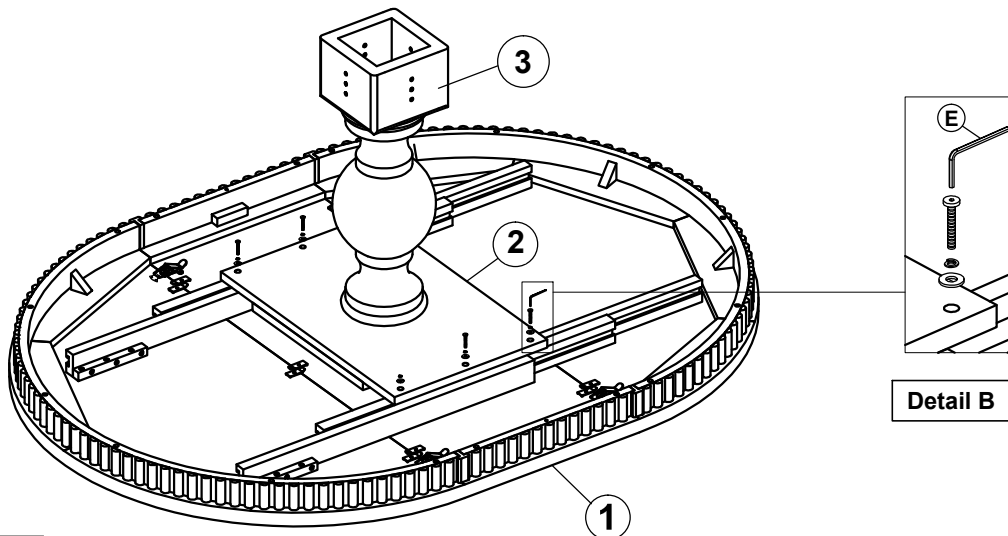

STEP 4

- Attach the Base Legs to the Pedestal using Nut, Lock Washer, Flat Washer and Key Wrench (D) provided. (See Detail C)
- Make sure all Nuts are securely tightened.
- With help from the second person, carefully turn the table upright.

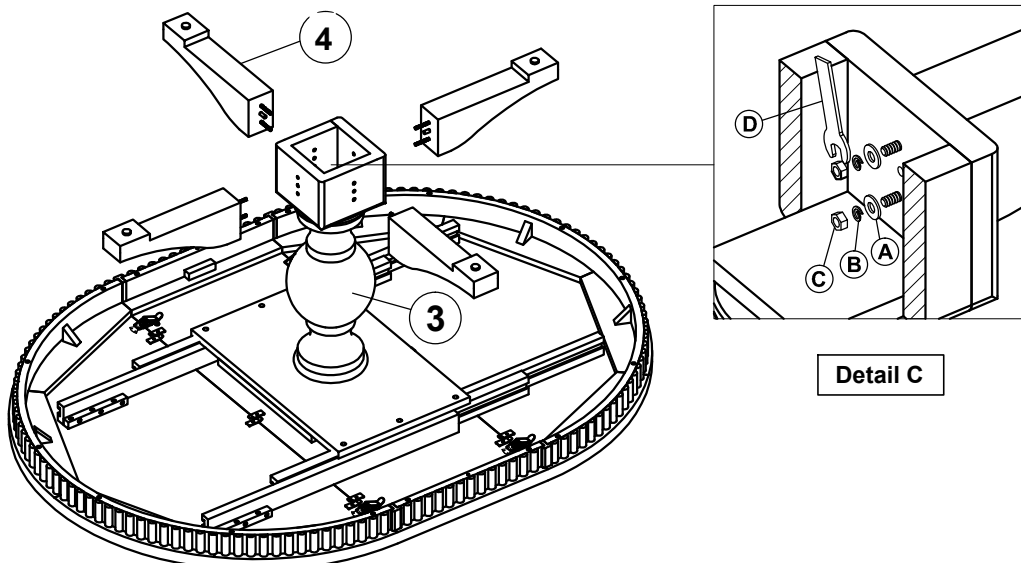



furnishing better
lives together[®]

WWW.JOFRAN.COM

ASSEMBLY INSTRUCTIONS & PARTS IDENTIFICATION

MODEL # 2546-66T/B

WESTPORT NAVY 48" ROUND/OVAL TOP

Thank you for purchasing this quality product. Be sure to check all packing material carefully for small parts that may have come loose inside the carton during shipment.

STEP 5

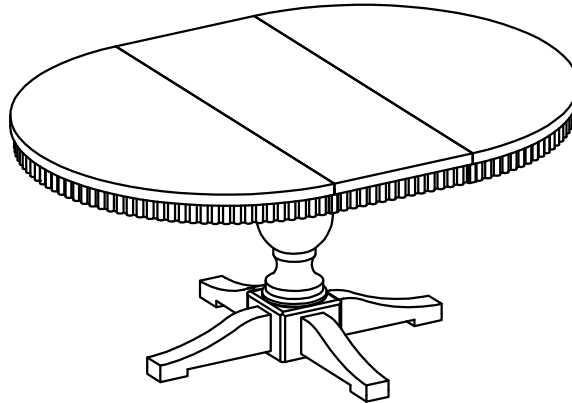

STEP 6

- Unlock the Extension Locks.
- With two people, pull both ends of the Table Top outward.
- Remove the Leaf Panel from the center.

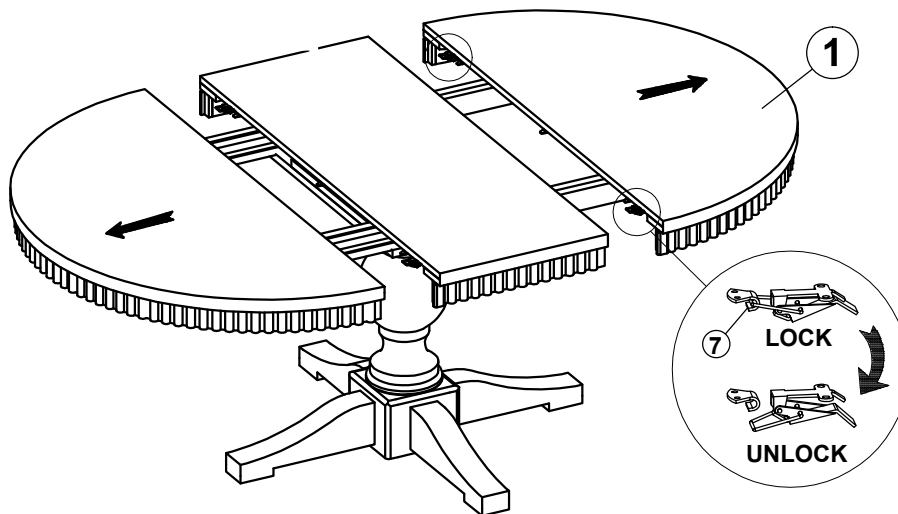

- When installing the Leaf Panel, make sure the alignment block on the panel is properly aligned and positioned between the two alignment blocks on the Mounting Plate underneath.

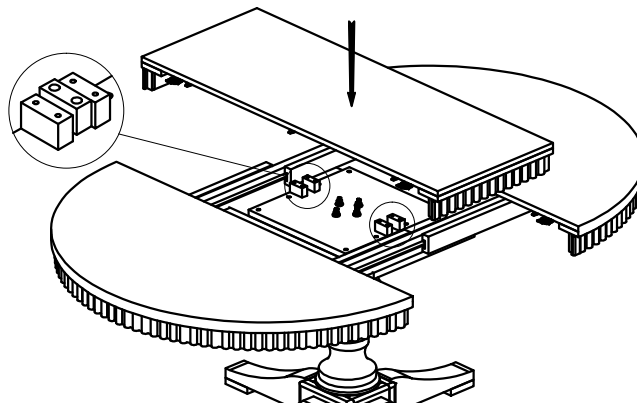



furnishing better
lives together[®]

WWW.JOFRAN.COM

**ASSEMBLY INSTRUCTIONS &
PARTS IDENTIFICATION**
MODEL # 2546-66T/B
WESTPORT NAVY 48" ROUND/OVAL TOP

Thank you for purchasing this quality product. Be sure to check all packing material carefully for small parts that may have come loose inside the carton during shipment.

STEP 7

- With two people, push both ends of the Table Top back together.
- Lock the Extension Locks.
- The table is now in round position.

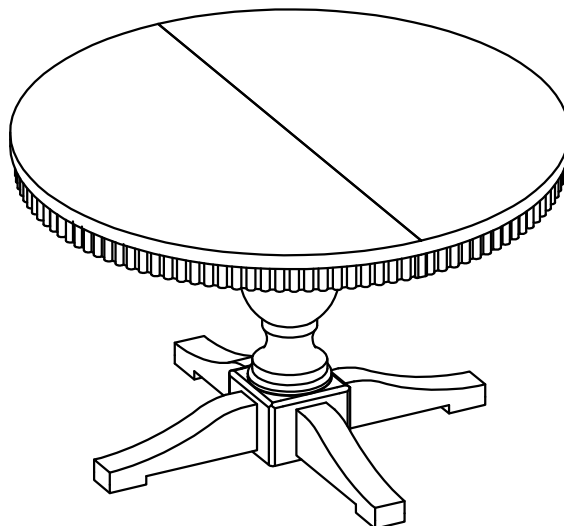
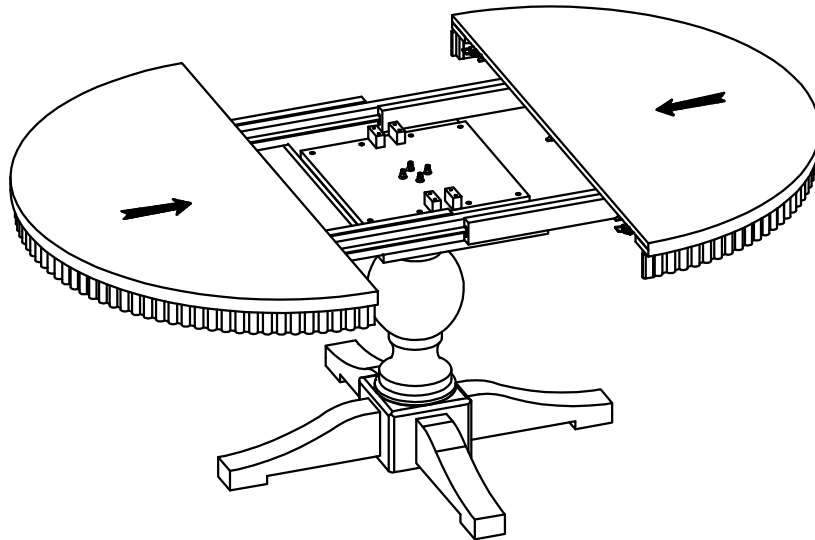

ASSEMBLY COMPLETED

DO NOT ATTEMPT TO TRANSPORT THE TABLE WITH THE BASE ATTACHED.
TOP MUST BE REMOVED AND TRANSPORTED AS TWO PIECES.