

WHITE : BLANC : *BLANCO*

DEEP GREY : GRIS PROFOND : *GRIS PROFONDO*

BARK GREY : GRIS ÉCORCE : *CORTEZA GRIS*

CHOCOLATE : CHOCOLAT : *CHOCOLATE*

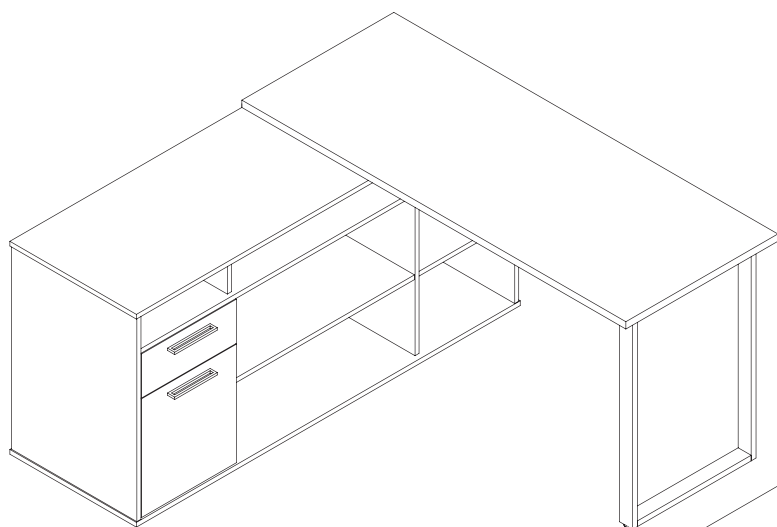

**ASSEMBLY
INSTRUCTIONS**

**INSTRUCTIONS
D'ASSEMBLAGE**

**INSTRUCCIONES DE
ENSAMBLAJE**

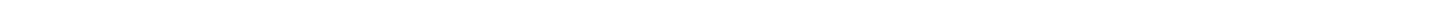

Thank you for choosing a product. Your total satisfaction is our #1 priority.

Customer Service and warranty information



MERCI D'AVOIR CHOISI LES PRODUITS. VOUS SATISFAIRE EST NOTRE PRIORITÉ.

Service à la clientèle et informations relatives à la garantie

***Gracias por elegir un producto.
Su entera satisfacción es nuestra prioridad N°1.***

Servicio de atención al cliente e información sobre la garantía

PARTS / PIÈCES / PIEZAS

01	1	20	2	42	1	67	1
02	1	21	2	43	1	70	1
09	1	30	2	44	1	CA05A	1
10	1	40	1	45	1	CA13A	1
15 bottom / fond / fondo 16" x 12 1/2" (406 mm x 316 mm)	2	41	1	66	1		



two people are required to assemble and move this model.
deux personnes sont requises pour assembler et déplacer ce modèle.
se necesitan dos personas para ensamblar y desplazar este mueble.

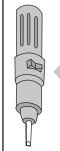





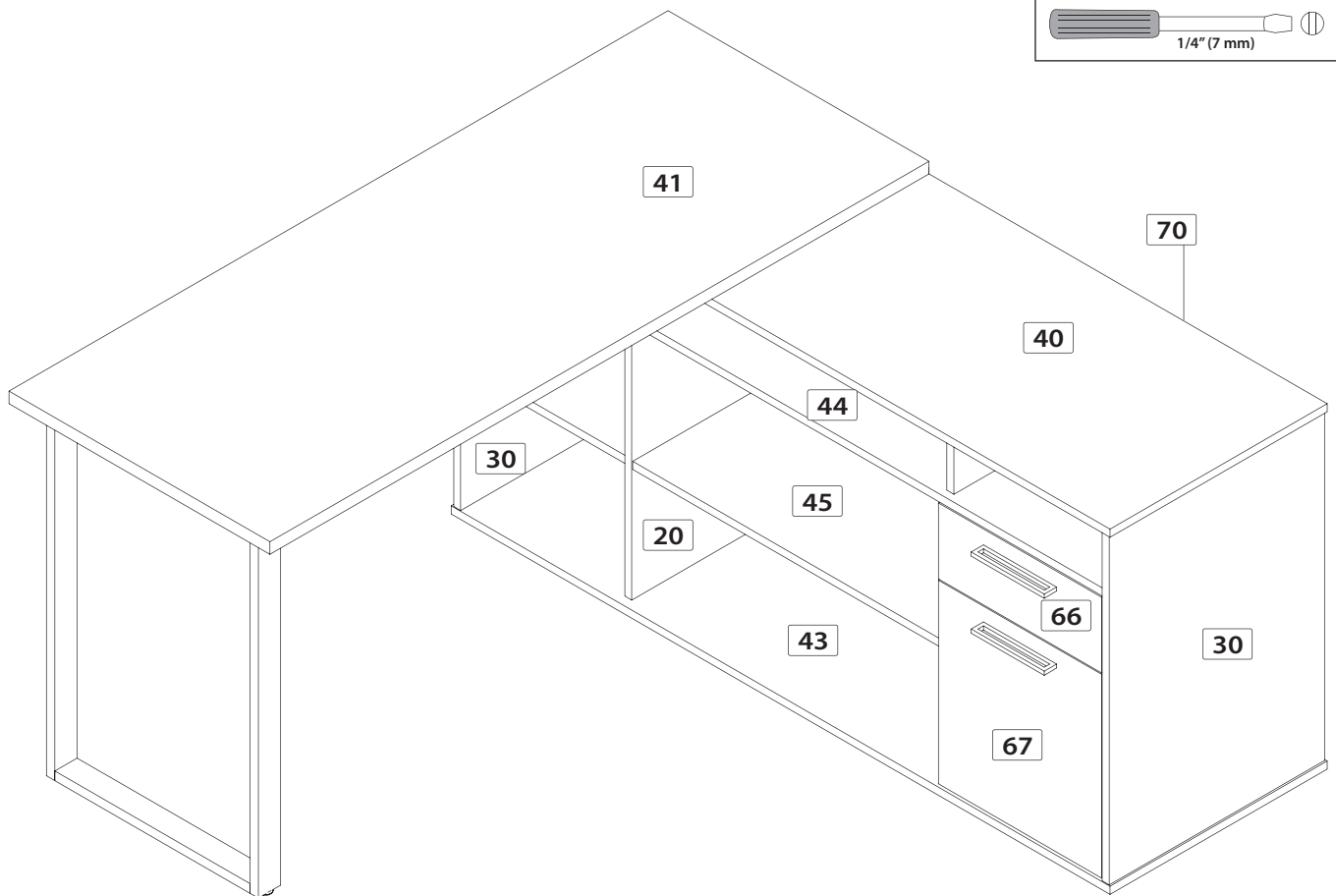
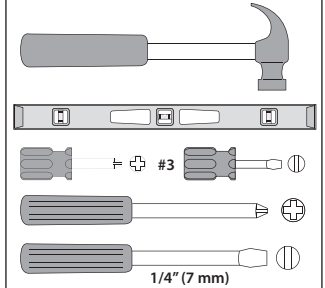









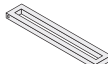

the use of electric tools must be made with vigilance.
l'utilisation d'outils électriques doit être faite avec vigilance.
las herramientas eléctricas deben utilizarse con sumo cuidado.

tools required
outils requis
herramientas necesarias

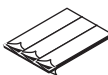

HARDWARE / QUINCAILLERIES / ARTÍCULOS DE FERRETERÍA

CODE / CÓDIGO	QTY / QTÉ / CANT.	CODE / CÓDIGO	QTY / QTÉ / CANT.	CODE / CÓDIGO	QTY / QTÉ / CANT.	CODE / CÓDIGO	QTY / QTÉ / CANT.				
AM-182	 1/16" (2 mm)	2	GO-796	 green / vert / verde	2	PA-7392	 1	TI-683	 11 5/8" (295 mm)	1	
CA-99		20	H-03		30	PA-97		6	3500-501627		2
CO-249	runners 406 mm (16") coulisseaux 406 mm correderas 40,6 cm	2	H-36		26	PO-778		2	TI-452		8
EX-743	 11 15/16" (30,3 cm)	2	H-04		10	RU-420		1			
	 16 3/16" (41,1 cm)		H-991		6	SU-682		2			

REAL SIZE / GRANDEUR RÉELLE / TAMAÑO REAL

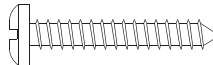
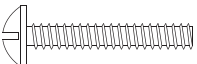
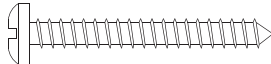
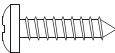
CODE / CÓDIGO	QTY / QTÉ / CANT.	CODE / CÓDIGO	QTY / QTÉ / CANT.		
VE-244	 3/8" (10 mm)	8	VR-212	 1" (25 mm)	8
VF-232	 7/8" (22 mm)	4	VR-213	 1 1/4" (32 mm)	4
VR-207	 1/2" (13 mm)	12			

▶ IMPORTANT NOTICE / NOTE IMPORTANTE / NOTA IMPORTANTE

Duly complete the self-adhesive sticker. / Assurez-vous de bien remplir l'autocollant. / Asegúrese de completar correctamente la etiqueta.

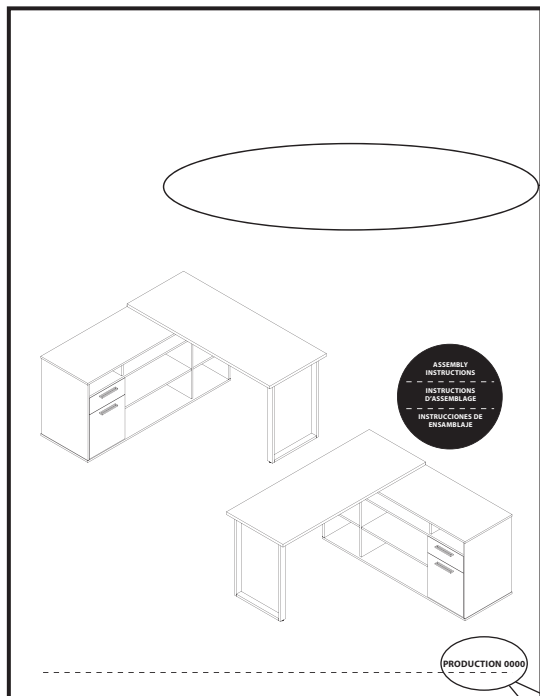

PRODUCTION 0000

To better serve you!
Pour mieux vous servir!

Model / Modèle: _____

Production Number
Numéro de production: _____

Customer Service
Service à la clientèle

Important/Importante

Please retain the self-adhesive sticker which you will find at step 9 of the instruction manual.

Conservez l'autocollant qui sera collé seulement à l'étape 9 du feuillet d'instructions.

Conserve la etiqueta que será pegada sólo en la etapa 9 de la hoja de instrucciones.

▶ IMPORTANT NOTICE / NOTE IMPORTANTE / NOTA IMPORTANTE

Main hardware system / Système de quincaillerie principal / Sistema principal de quincalla

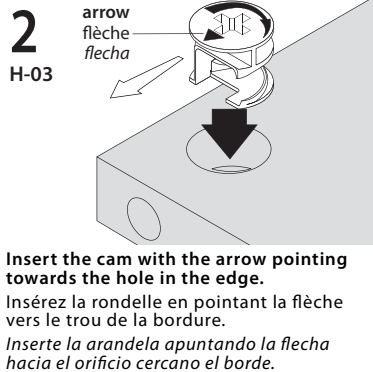
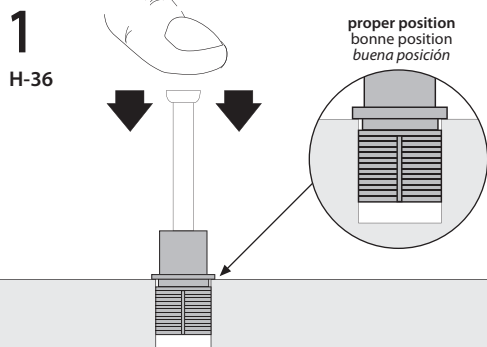

If needed / En cas de nécessité
En caso de necesidad

How to remove a misplaced assembly bolt (H-36).
Comment retirer un boulon (H-36) mal situé.
Cómo retirar un perno (H-36) mal ubicado.

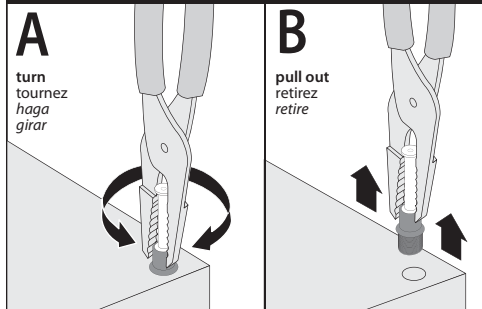

Assembling sequence
 Séquence d'assemblage
 Secuencia de ensamblaje
 Parts / Pièces / Piezas:

- 70
- 30
- 44
- 30

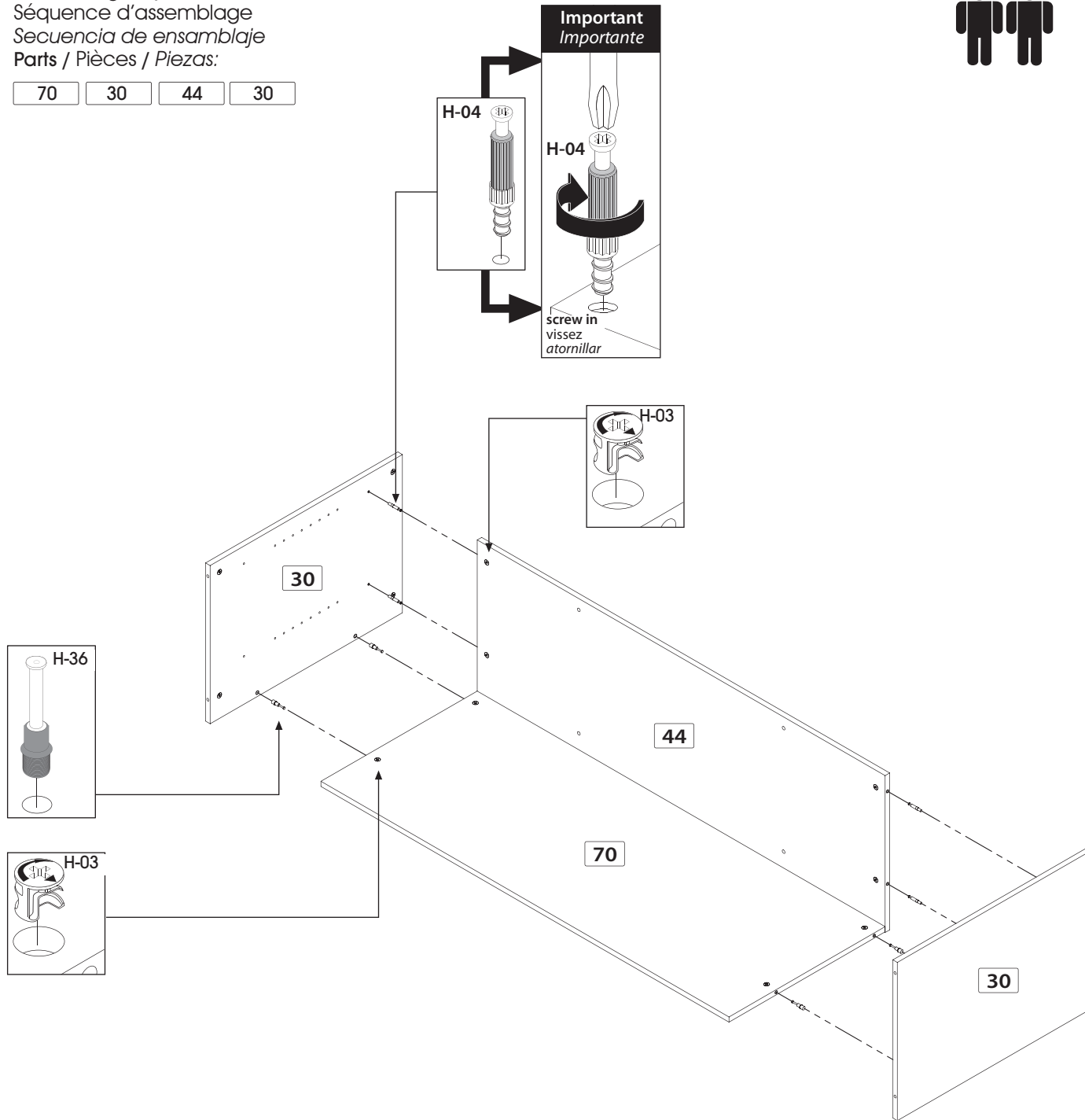

Important
 Importante

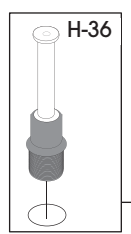
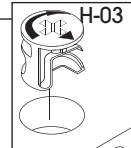
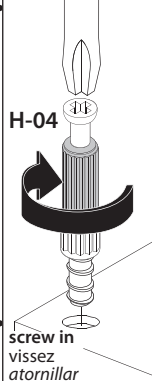

When you have completed the assembly of your new furniture, install plastic caps.
 Lorsque vous avez complété l'assemblage de votre meuble, installez les capuchons de plastique.
 Una vez que haya ensamblado el mueble, coloque los capuchones de plástico.

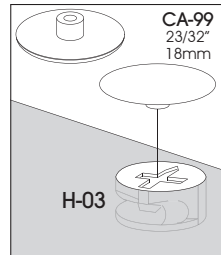

Code / Código	H-03	H-36	H-04
Qty / Qté / Cant.	x 16	x 4	x 4

Assembling sequence

Séquence d'assemblage

Secuencia de ensamblaje

Parts / Pièces / Piezas:

30 44 30 + 20 20 43

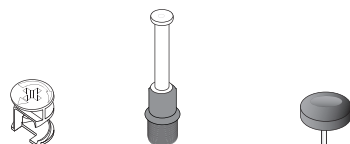
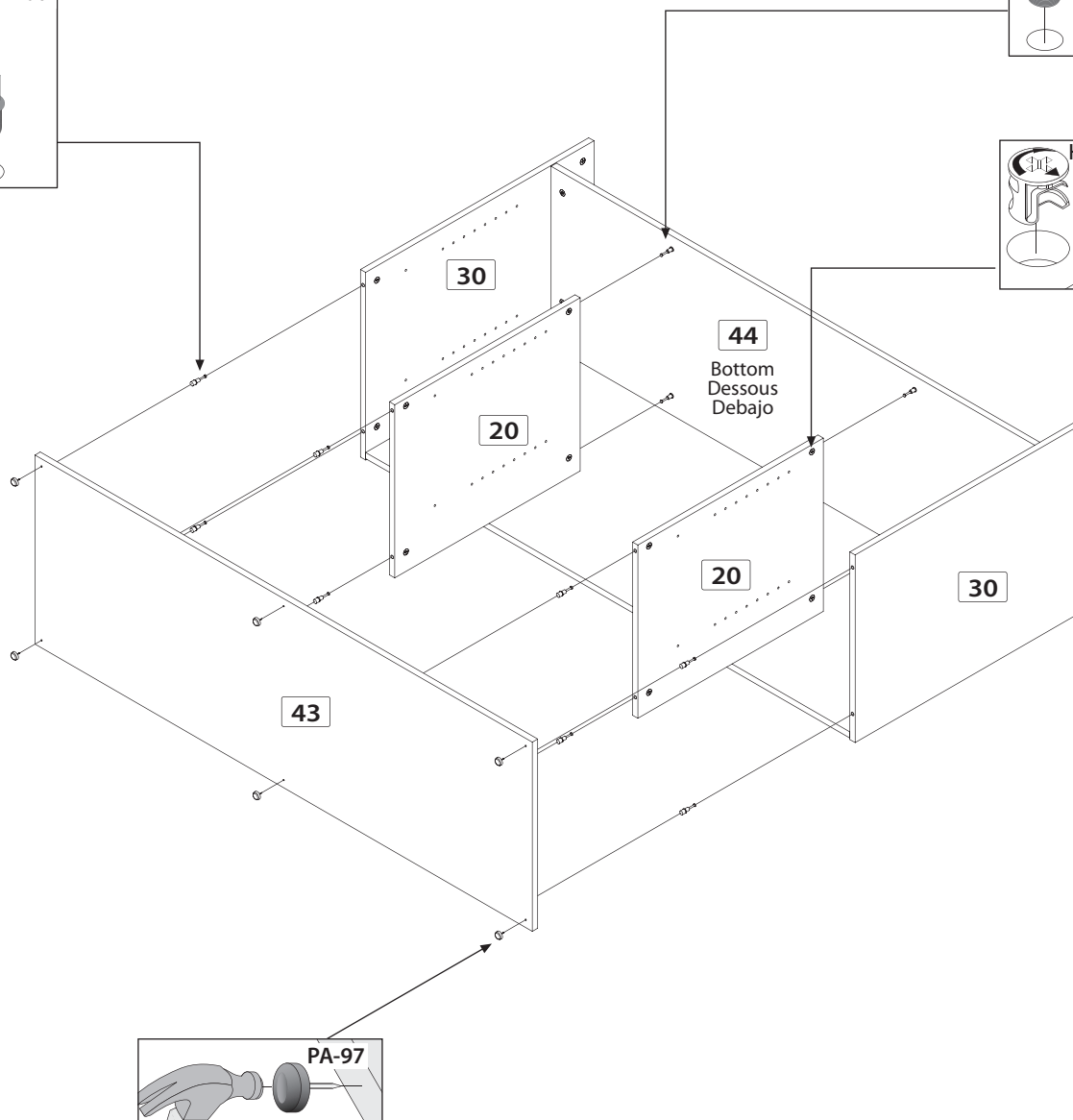
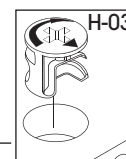
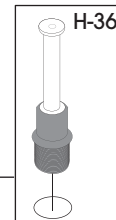
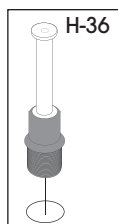

Code / Código

H-03

H-36

PA-97

Qty / Qté / Cant.

x 8

x 12

6



Assembling sequence
 Séquence d'assemblage
 Secuencia de ensamblaje
Parts / Pièces / Piezas:

30 44 30 + **21 21 40**

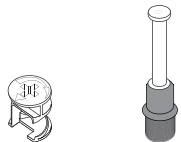
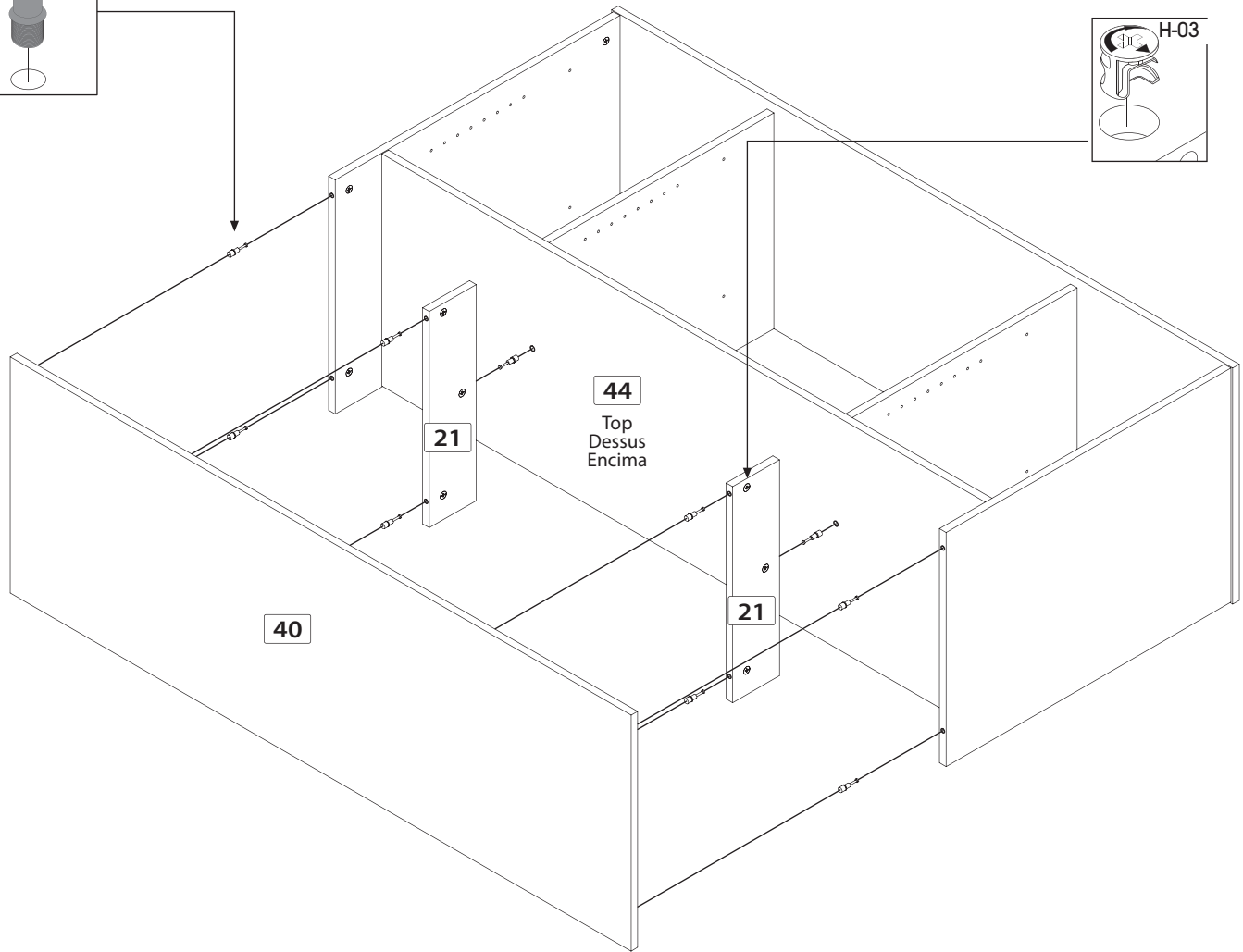
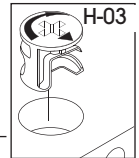
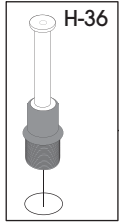

Code / Código	H-03	H-36
Qty / Qté / Cant.	x 6	x 10



Important/Importante

RU-420



Remove paper on one side only of RU-420.
Retirez le papier sur seulement une des faces du RU-420.
Retire el papel de sólo uno de los costados del RU-420.

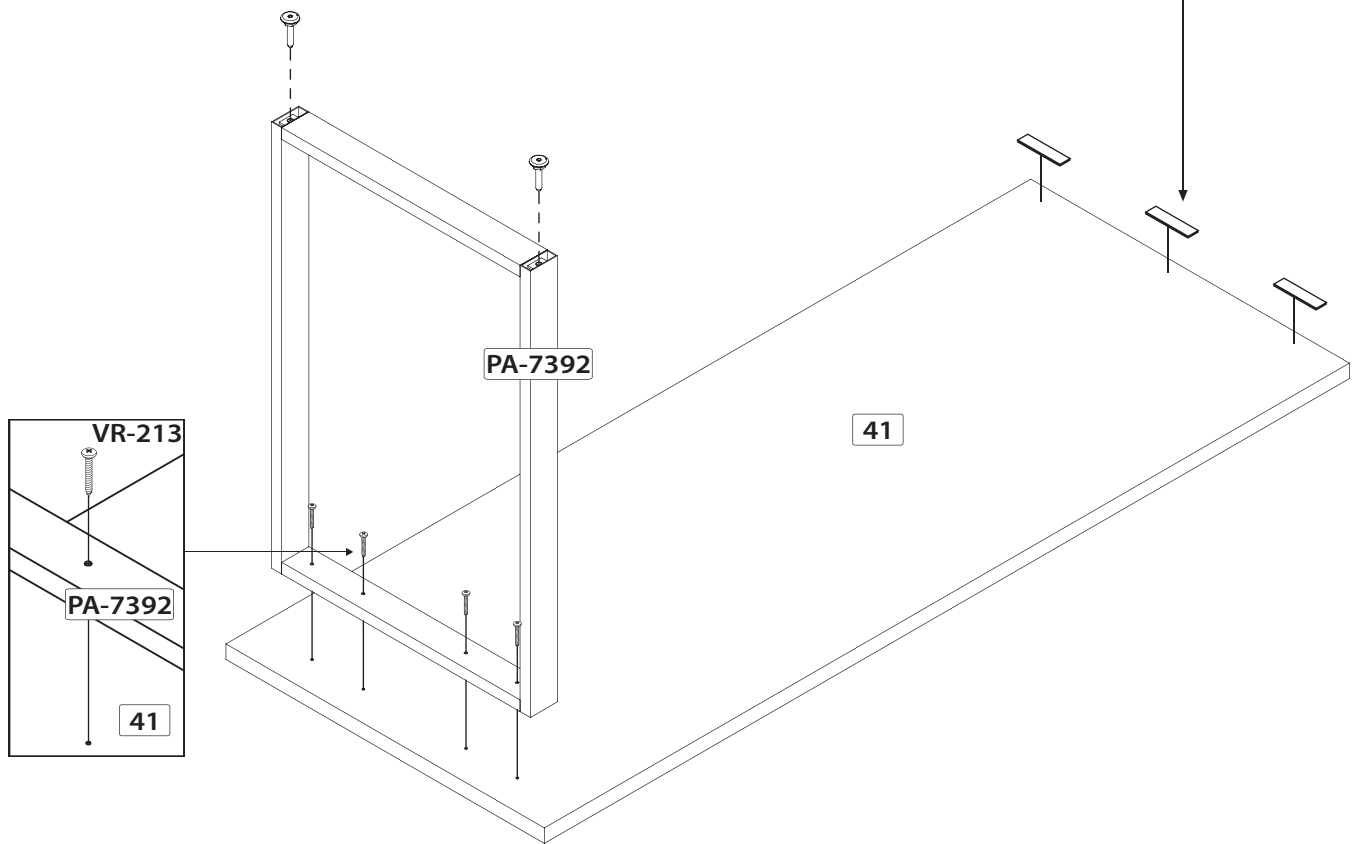

4

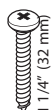

VR-213

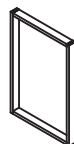

PA-7392



3500-501627



RU-420

Code / Código

Qty / Qté / Cant.

x 4

x 1

x 2

x 1

Important/Importante

RU-420



Remove paper from RU-420.
Retirez le papier du RU-420.
Retire el papel del RU-420.



RIGHT ASSEMBLY INSTRUCTIONS P.11-12-13
INSTRUCTIONS D'ASSEMBLAGE DROIT P.11-12-13
INSTRUCCIONES DE ENSAMBLAJE DERECHO P.11-12-13

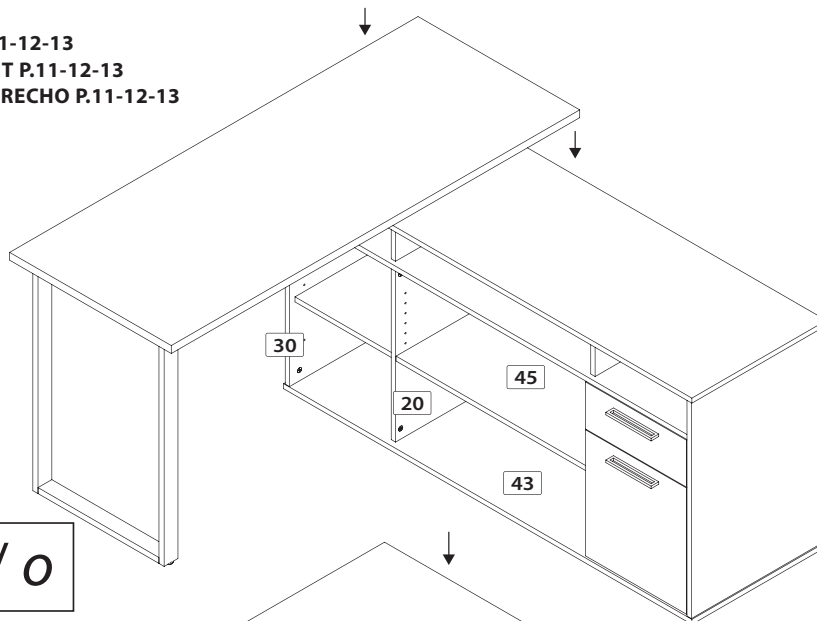

or / ou / o

LEFT ASSEMBLY INSTRUCTIONS P.14-15-16
INSTRUCTIONS D'ASSEMBLAGE GAUCHE P.14-15-16
INSTRUCCIONES DE ENSAMBLAJE IZQUIERDO P.14-15-16

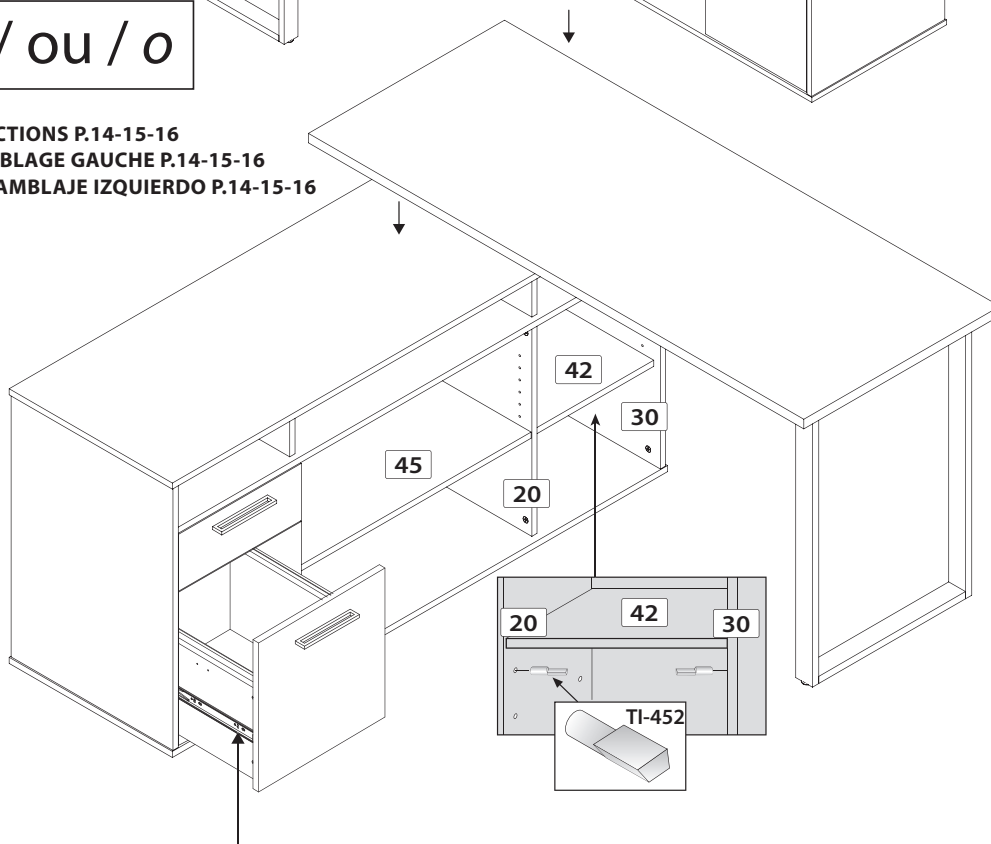

Important / Importante

09

Use screw for vertical adjustment.
Utilisez la vis pour l'ajustement vertical.
Utilice el tornillo para el ajuste vertical.

5	
Code / Código	TI-452
Qty / Qté / Cant.	x 8

Important/Importante

2 possibilities / 2 possibilités / 2 posibilidad
Installation of drawers to the left or to the right
 Installation des tiroirs à gauche ou à droite
 Instalación de cajones a la izquierda o a la derecha

**Attention / Atención**

Refer to page 14 for the left assembly.
 Référez-vous à la page 14 pour l'assemblage gauche.
 Vea la paje 14 para el ensamblaje izquierdo.

RIGHT ASSEMBLY INSTRUCTIONS
INSTRUCTIONS D'ASSEMBLAGE DROIT
INSTRUCCIONES DE ENSAMBLAJE DERECHO

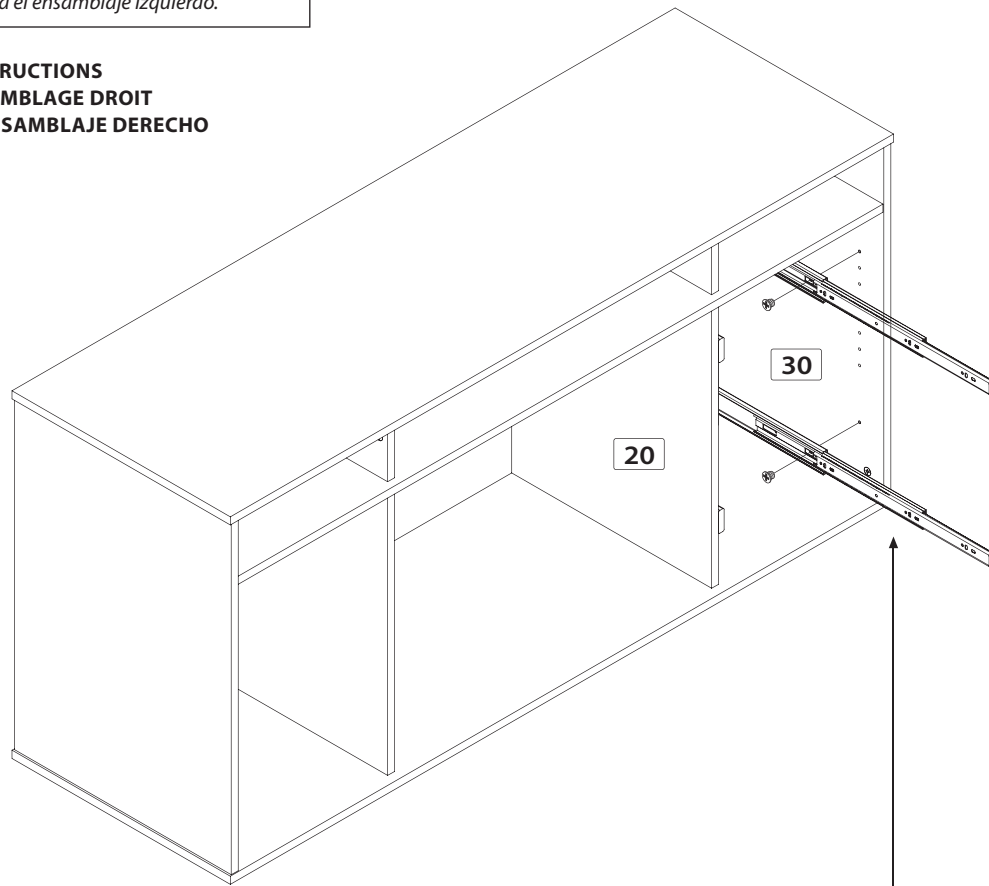

CO-249

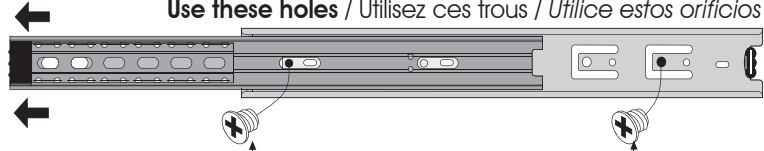

VE-244



Code / Código

CO-249

Qty / Qté / Cant.

x 2



VE-244

x 8

Assembling sequence
 Séquence d'assemblage
 Secuencia de ensamblaje
 Parts / Pièces / Piezas:

CA13A EX-681 09 EX-702 10 EX-702
 bottom / fond / fondo + 67

RIGHT ASSEMBLY INSTRUCTIONS
INSTRUCTIONS D'ASSEMBLAGE DROIT
INSTRUCCIONES DE ENSAMBLAJE DERECHO

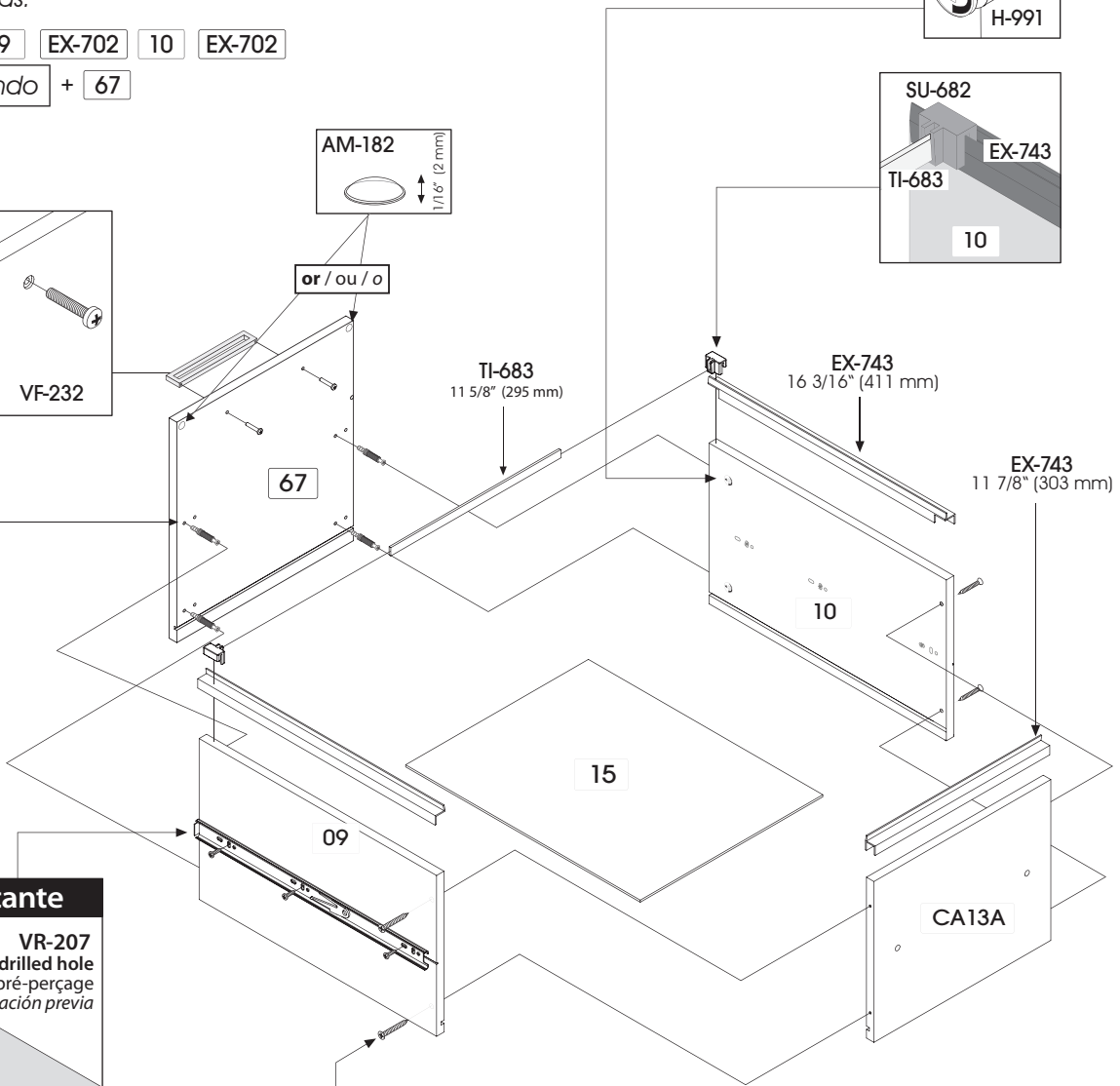
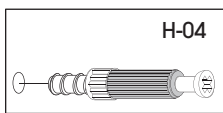
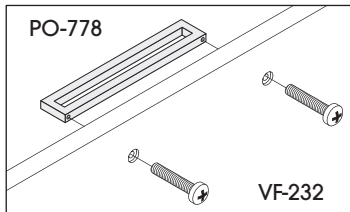
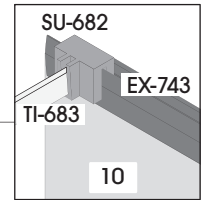
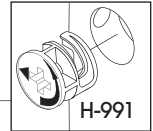

important / importante

CO-249 VR-207
 without pre-drilled hole
 sans pré-perçage
 sin perforación previa

align
 aligner
 alinear

Use the remaining piece from step 4
 Utilisez la section restante de l'étape 4
 Utilizar la sección restante de la etapa 4

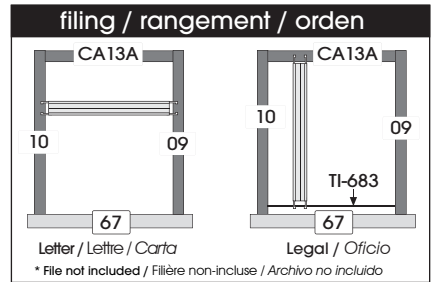
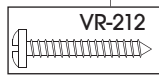

Code / Código	EX-743	H-991	H-04	PO-778	SU-682	TI-683	VR-207	VF-232	VR-212	AM-182
Qty / Qté / Cant.	x 1	x 4	x 4	x 1	x 2	x 1	x 6	x 2	x 4	x 1

RIGHT ASSEMBLY INSTRUCTIONS
INSTRUCTIONS D'ASSEMBLAGE DROIT
INSTRUCCIONES DE ENSAMBLAJE DERECHO

Assembling sequence
 Séquence d'assemblage
 Secuencia de ensamblaje
 Parts / Pièces / Piezas:

01 CA05A 02 + bottom / fond / fondo + 66

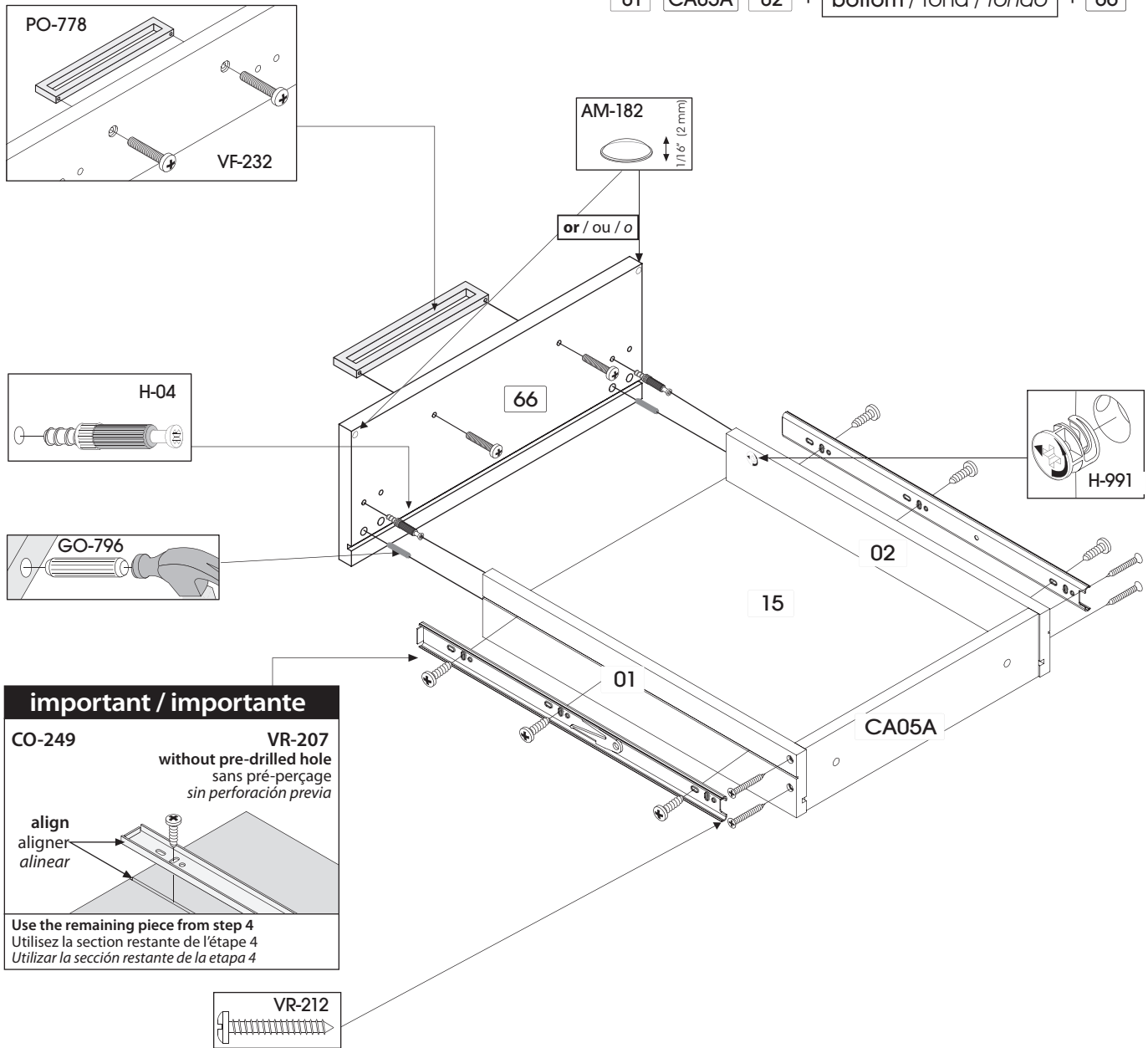

Code / Código	CO-249	AM-182	PO-778	VR-207	VF-232	VR-212	H-991	H-04	GO-796
Qty / Qté / Cant.	x 2	x 1	x 1	x 6	x 2	x 4	x 2	x 2	x 2

LEFT ASSEMBLY INSTRUCTIONS
INSTRUCTIONS D'ASSEMBLAGE GAUCHE
INSTRUCCIONES DE ENSAMBLAJE IZQUIERDO



Important/Importante
2 possibilities / 2 possibilités / 2 posibilidad
Installation of drawers to the left or to the right
Installation des tiroirs à gauche ou à droite
Instalación de cajones a la izquierda o a la derecha

Attention / Atención
Refer to page 11 for the right assembly.
Référez-vous à la page 11 pour l'assemblage droit.
Vea la paje 11 para el ensamblaje derecho.

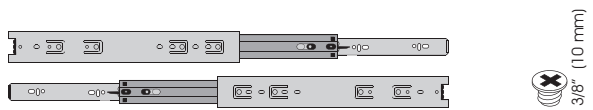
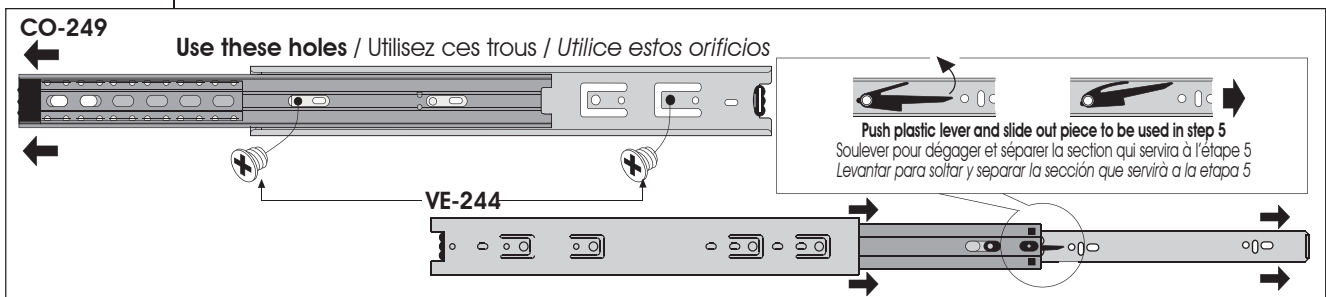
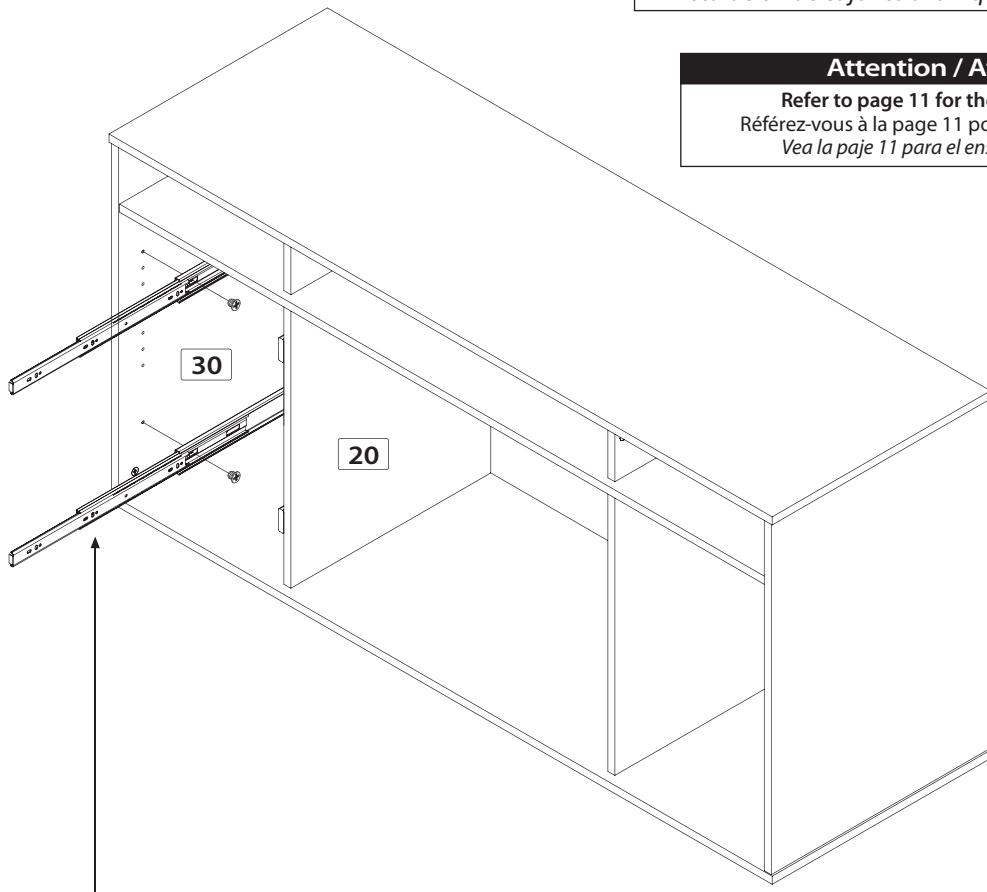

Code / Código	CO-249	VE-244
Qty / Qté / Cant.	x 2	x 8

Assembling sequence
 Séquence d'assemblage
 Secuencia de ensamblaje
 Parts / Pièces / Piezas:

CA13A EX-681 09 EX-702 10 EX-702
 bottom / fond / fondo + 67

LEFT ASSEMBLY INSTRUCTIONS
INSTRUCTIONS D'ASSEMBLAGE GAUCHE
INSTRUCCIONES DE ENSAMBLAJE IZQUIERDO

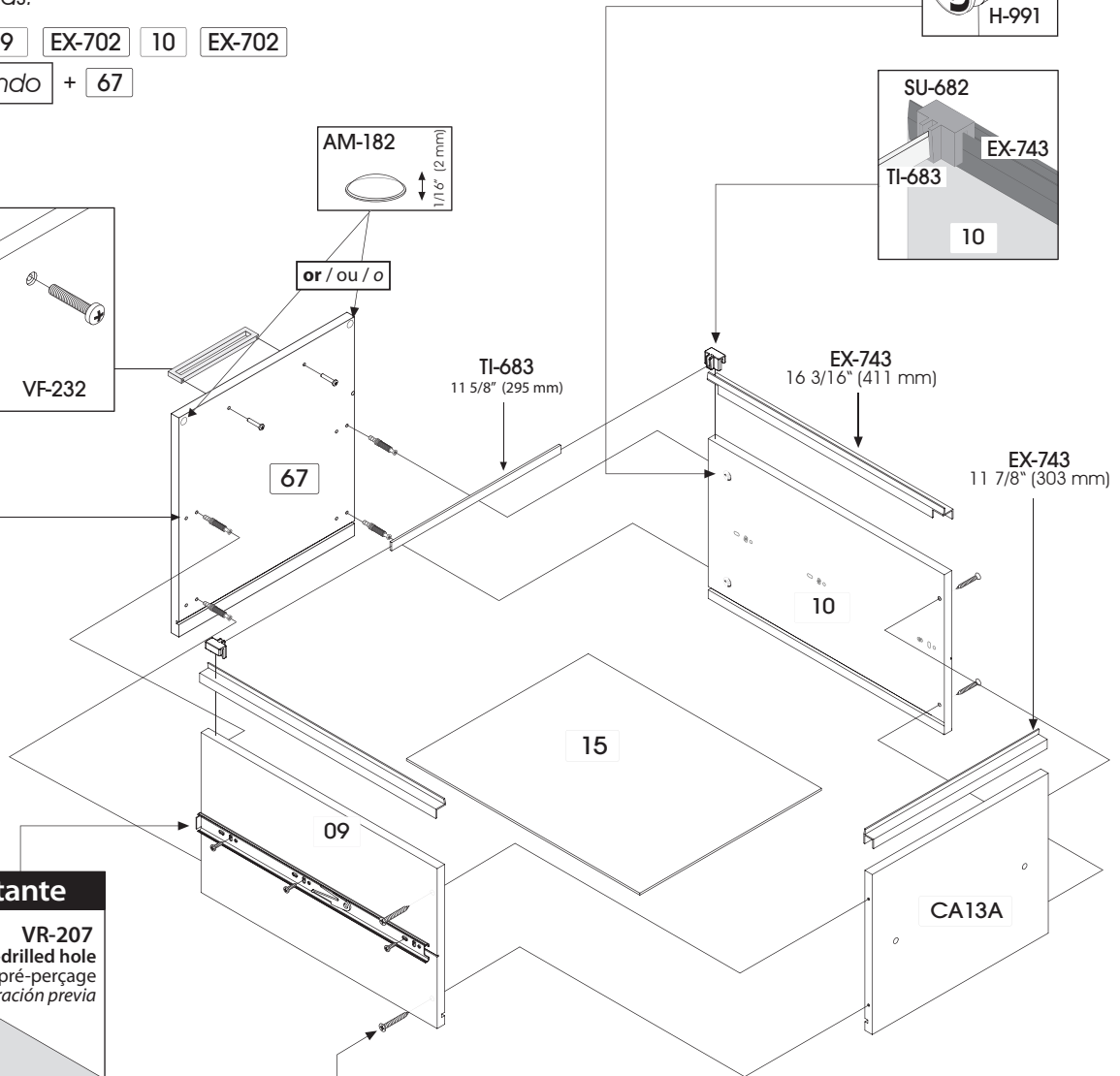
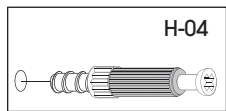
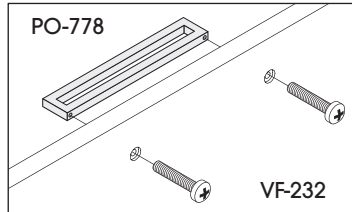
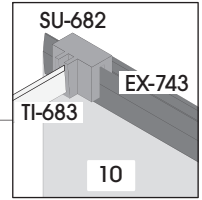
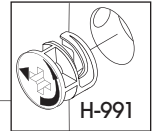

important / importante

CO-249 **VR-207**
 without pre-drilled hole
 sans pré-perçage
 sin perforación previa

align
 aligner
 alinear

Use the remaining piece from step 4
 Utilisez la section restante de l'étape 4
 Utilizar la sección restante de la etapa 4

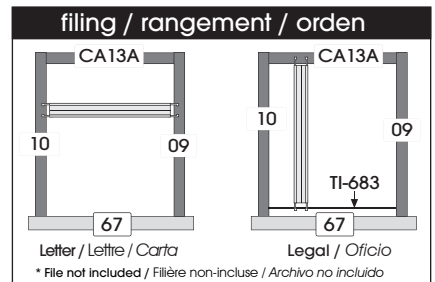

Code / Código	CO-249	EX-743	H-991	H-04	PO-778	SU-682	TI-683	VR-207	VF-232	VR-212	AM-182
Qty / Qté / Cant.	x 2	x 1	x 4	x 4	x 1	x 2	x 1	x 6	x 2	x 4	x 1

LEFT ASSEMBLY INSTRUCTIONS
INSTRUCTIONS D'ASSEMBLAGE GAUCHE
INSTRUCCIONES DE ENSAMBLAJE IZQUIERDO

Assembling sequence
 Séquence d'assemblage
 Secuencia de ensamblaje
 Parts / Pièces / Piezas:

01 CA05A 02 + bottom / fond / fondo + 66

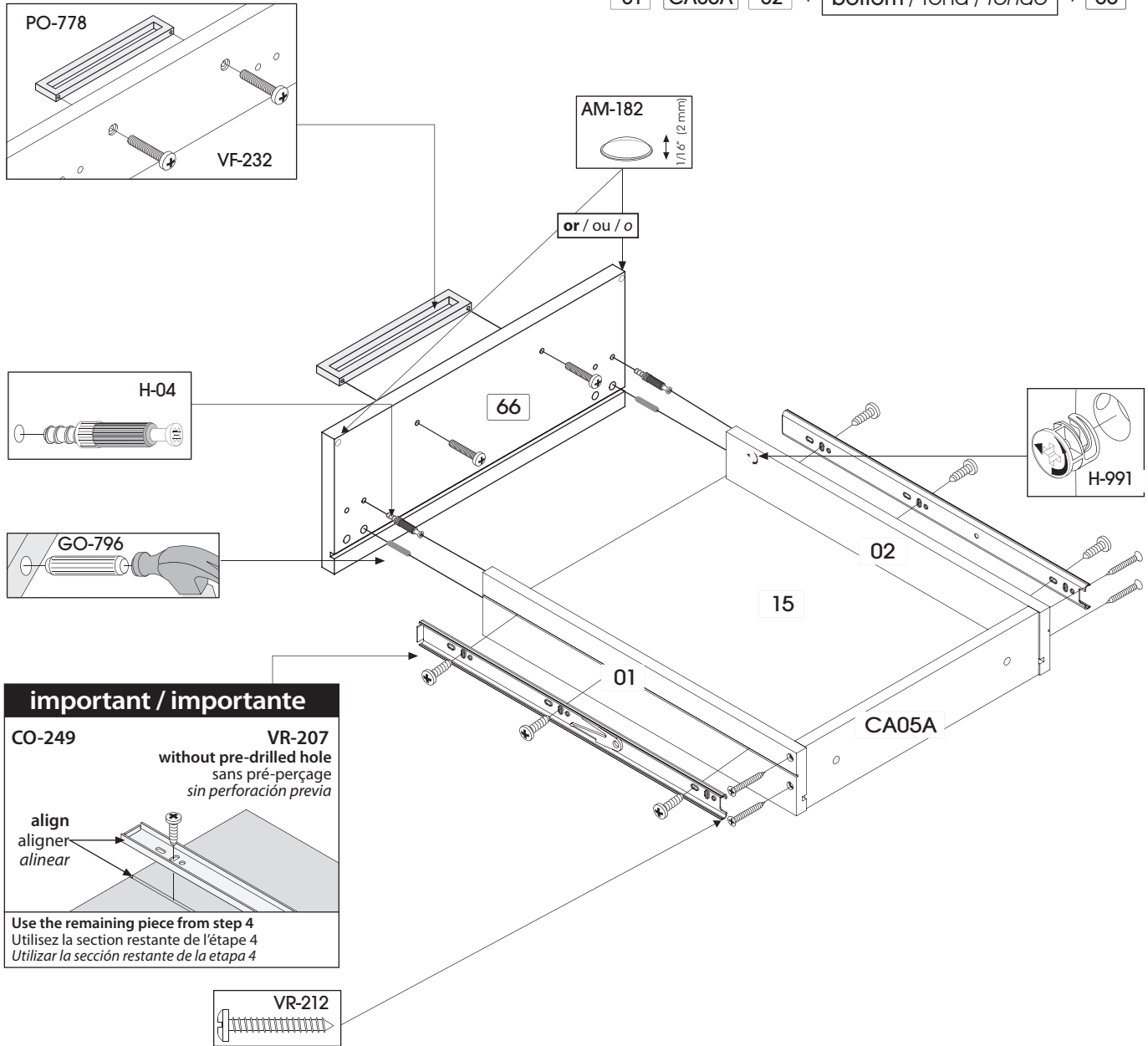

important / importante

CO-249 **VR-207**
 without pre-drilled hole
 sans pré-perçage
 sin perforación previa

align
 aligner
 alinear

Use the remaining piece from step 4
 Utilisez la section restante de l'étape 4
 Utilizar la sección restante de la etapa 4

Code / Código	CO-249	AM-182	PO-778	VR-207	VF-232	VR-212	H-991	H-04	GO-796
Qty / Qté / Cant.	x 2	x 1	x 1	x 6	x 2	x 4	x 2	x 2	x 2

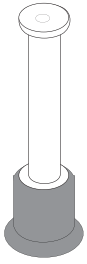

You are at a step of hardware installation and some H-36 are missing:

Before calling to order your missing bolts (H-36), please make sure you have not installed any bolts (H-36) in the wrong place. To remove a bolt (H-36) which is not in the correct place, please refer to your instruction manual.

Vous êtes à une étape d'installation de quincaillerie et il vous manque des H-36 :

Avant d'appeler pour commander des boulons (H-36), assurez-vous de ne pas avoir installé des boulons (H-36) au mauvais endroit. Pour enlever un boulon (H-36) mal situé, consultez le feuillet d'instructions.

Usted está en alguna etapa de la instalación de quincallas y le faltan las H-36 :

Antes de llamar para pedir los pernos (H-36), asegúrese de que no los haya instalado en el lugar equivocado.

Para retirar un perno (H-36) mal puesto, consulte el folleto de instrucciones.

How to separate and install your CO-249 and CO-684 slides:

The CO-249 & CO-684 slides consist of two sections which you must separate. To separate the slides, please refer to your instruction manual. The slides are installed on distinct parts which will be re-grouped only when the drawers are installed on the furniture.

Comment séparer et installer les coulisseaux CO-249 et CO-684 :

Les coulisseaux CO-249 et CO-684 sont constitués d'une partie que vous devez séparer en deux sections. Pour séparer le coulisseau, référez-vous au feuillet d'instructions. Les coulisseaux sont installés sur deux pièces distinctes et seront regroupés seulement lors de l'installation des tiroirs dans le meuble.

Cómo separar y instalar las guías correderas CO-249 y CO-684 :

Las guías correderas CO-249 y CO-684 están constituidas por una parte que usted debe separar en dos secciones. Para separar las guías correderas, consulte el folleto de instrucciones. Las guías correderas se instalan en dos piezas distintas y sólo serán reagrupadas una vez se instalen los cajones en el mueble.

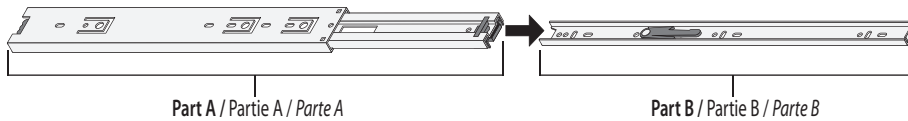

PRODUCT CARE / ENTRETIEN DU PRODUIT / MANTENIMIENTO DEL PRODUCTO

Avoid placing the furniture in the sunlight or near a source of heat. Use a soft dry cloth for dusting. To clean heavy dirt, use a cloth dipped in a solution of mild detergent and water. Avoid leaving wet objects on the surface or using commercial chemical cleaning products.

Évitez d'exposer le meuble au soleil ou près de toute source de chaleur. Pour le nettoyage, utilisez un chiffon doux et sec. Pour la grosse saleté, utilisez un chiffon humidifié avec un peu de détergent dilué dans l'eau. Évitez de laisser des objets mouillés sur la surface de votre meuble ou d'utiliser des nettoyeurs chimiques.

Evite exponer el mueble al sol o las fuentes de calor. Para limpiarlo, utilice un paño suave y seco. Para limpiar las manchas rebeldes, utilice un trapo húmedo con un poco de detergente diluido en agua. No deje objetos mojados encima del mueble ni utilice limpiadores que contengan productos químicos.

CONGRATULATIONS! YOU ARE NOW THE OWNER OF A QUALITY PRODUCT
FÉLICITATIONS! VOUS AVEZ MAINTENANT EN VOTRE POSSESSION UN PRODUIT DE QUALITÉ
¡FELICIDADES! AHORA ES USTED DUEÑO DE UN PRODUCTO DE CALIDAD.



For more information or to discover our new products

Pour toute information ou pour découvrir nos nouveaux produits

Para obtener más información o para obtener nuevos productos



**YOU
and US**

**VOUS
et NOUS**

**USTEDES y
NOSOTROS**

FOR LONG TIME
POUR LONGTEMPS
POR MUCHO TIEMPO