

ASSEMBLY INSTRUCTIONS



CAUTION

- Inspect the wire insulation for any cuts, abrasions or exposed copper that may have resulted during shipping. If there is a defect in the wire, do not attempt installation.
- Before starting installation of this fixture or removal of a previous fixture, disconnect the power by turning off the circuit breaker or by removing the fuse at the fuse box.

TOOLS REQUIRE

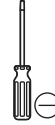
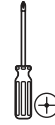

* PARTS SHOWN MAY DIFFER SLIGHTLY PER LIGHT FIXTURE

HARDWARE INCLUDED



Fixture

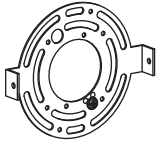

Mounting Unit



Screws



Rubber Rings



Mounting Screws



Wire Nuts

EXPLODED PARTS

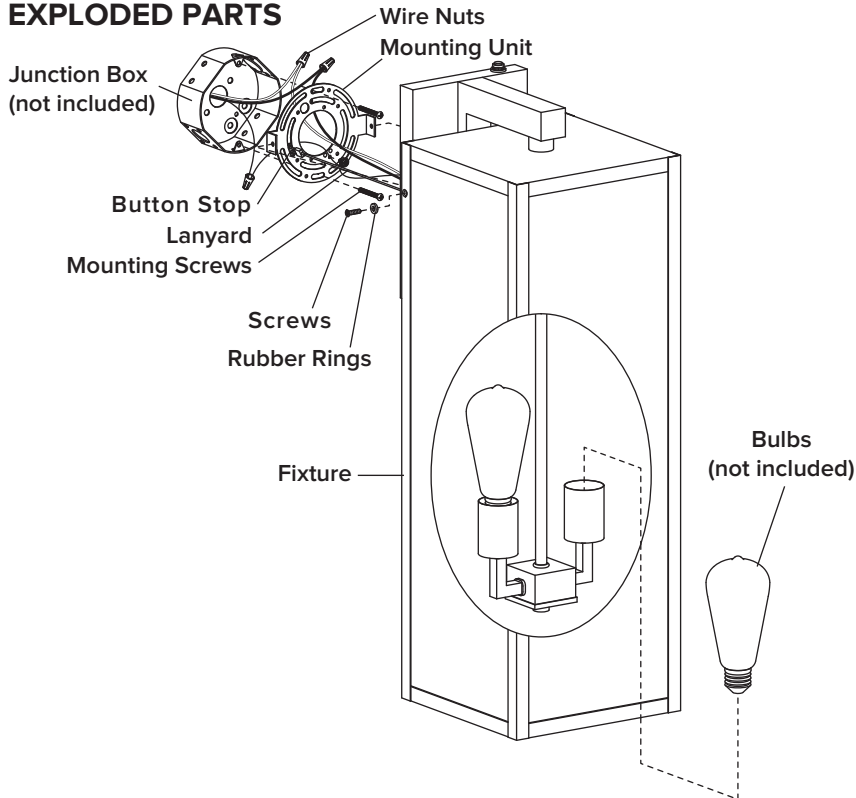

STEP 2

Turn the **button stop** from the **lanyard** and insert it completely inside the slot of **mounting unit**. This enables the **fixture** to hang from the **mounting unit** and your hands are free to make the wire connections.

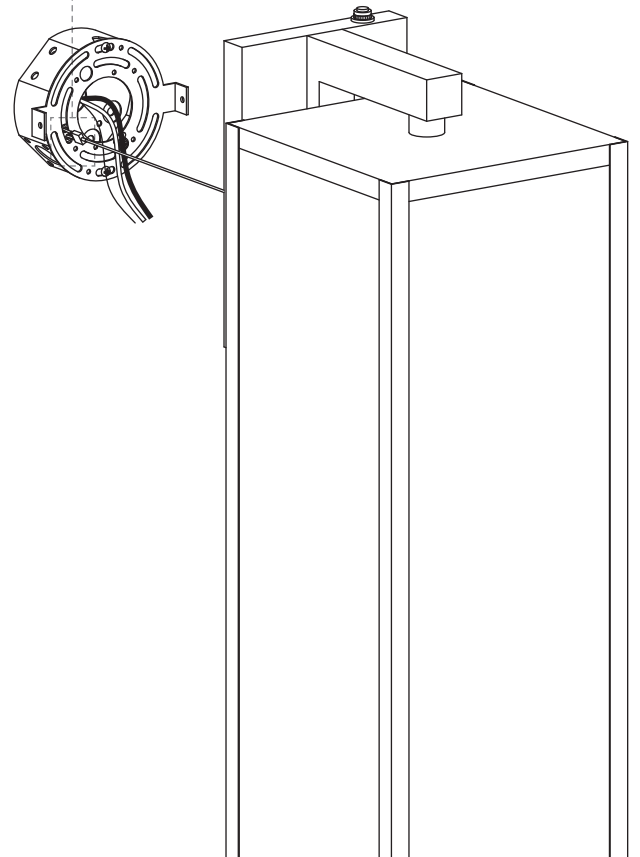
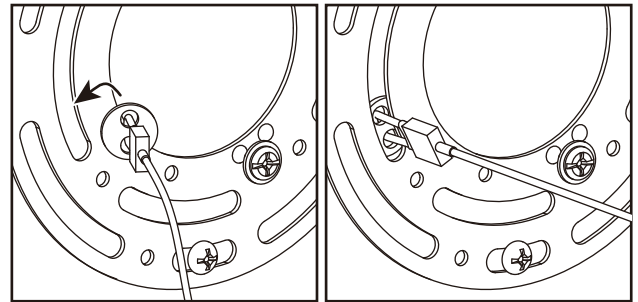

INSTALLATION

STEP 1

Unscrew the **rubber rings** and **screws** from the **mounting unit**. Use the **mounting screws** to attach the **mounting unit** to the junction box(not included).

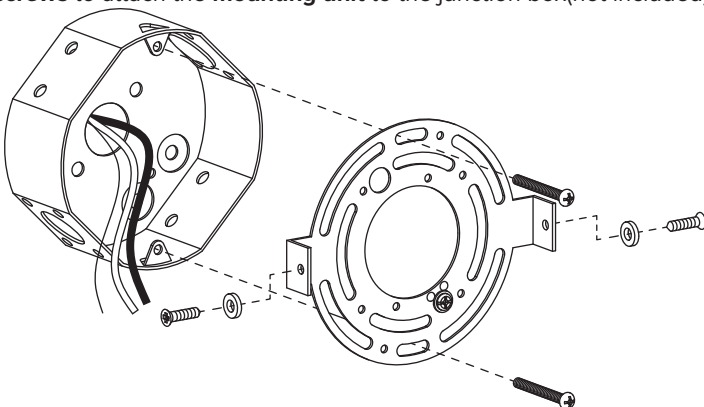

STEP 3

Make the electrical connection from the junction box (not included) to the **fixture**. Connect the ground wire to the **mounting unit** using the preinstalled green ground screw. Next, connect the live wire, neutral wire and ground wires with the supplied **wire nuts**. Secure with electrical tape.

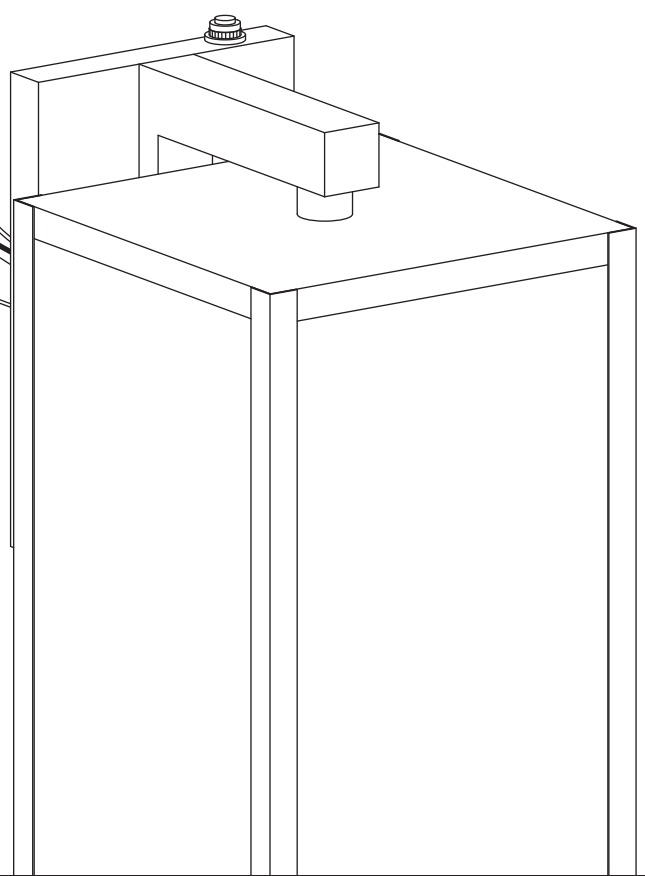
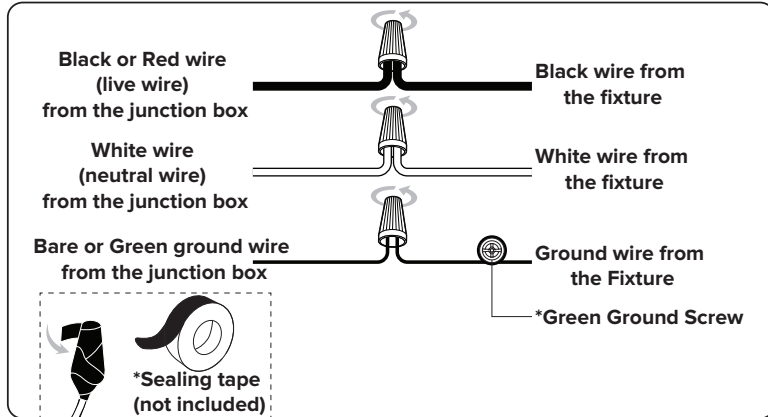
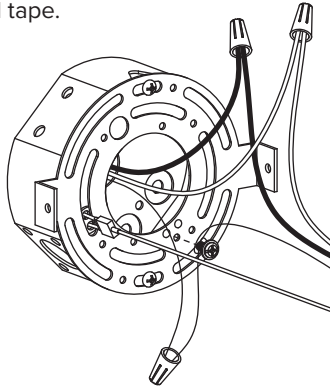

STEP 4

Attach the **fixture** to the **mounting unit** through **screw holes** as shown, and secure it with **rubber rings** and **screws**.

NOTICE: Please use caulk in the back plate and wall mounting surface to prevent water from entering.

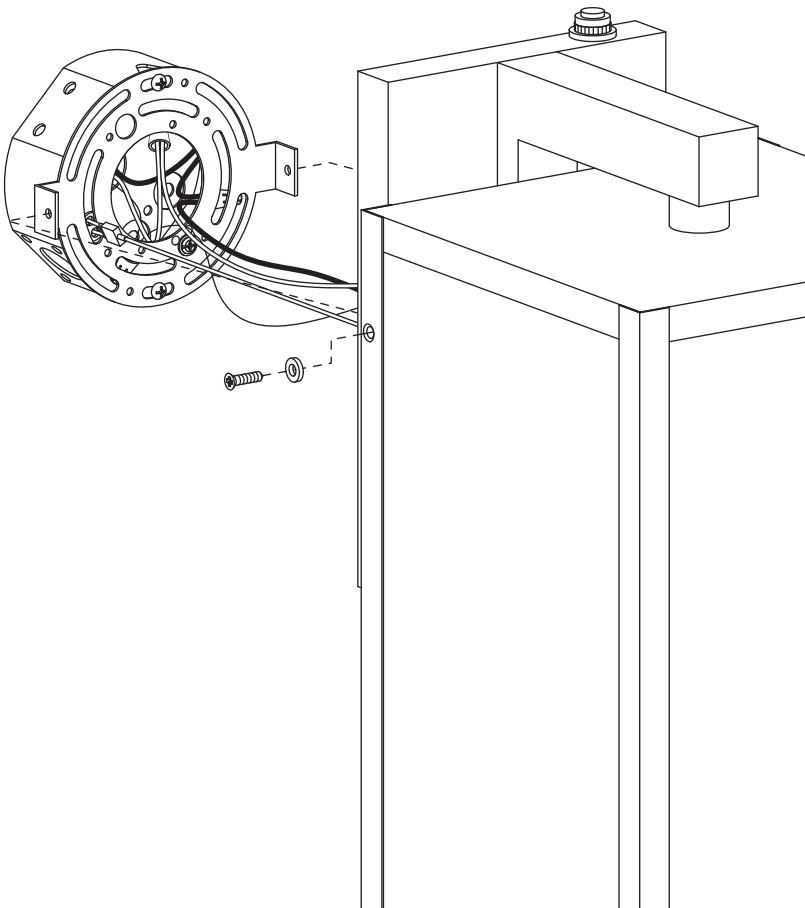

STEP 5

Install bulbs (not included).

