

MONTERINGSANVISNING BUFFÉSKÅP

ASSEMBLY INSTRUCTIONS SIDEBOARD

MONTAGEANLEITUNG SIDEBOARD

INSTRUCTIONS DE MONTAGE BAHUT

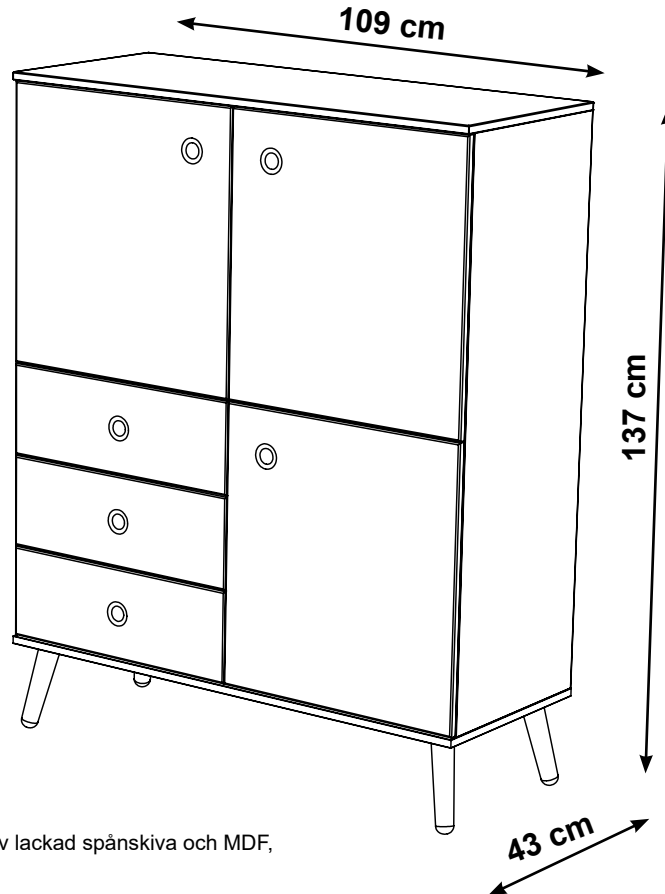

PRODUKTBESKRIVNING

Bufféskåp med 3 dörrar och 3 lådor. Möbeln är tillverkad av lackad spånskiva och MDF, toppskiva med lackad ekfaner. Ben av lackad massiv ek.

PRODUCT DESCRIPTION

Sideboard 3 doors 3 drawers. Made of lacquered chipboard and MDF, top - lacquered oak veneer. Leg of lacquered solid oak.

PRODUKTBESCHREIBUNG

Sideboard mit 3 Türen und 3 Schubladen. Spanplatte und MDF lackiert; Topplatte aus Eiche Furnier. Lackiert. Beine aus massiver Eiche. Lackiert.

DESCRIPTION DU PRODUIT

Bahut 3 ports et 3 tiroirs. MDF et Panneaux de particules laques, plateau en de placage chene lacque. Pieds chene massif - lacque.

VIKTIGT

Läs notisen innan ni börjar. Kontrollera innehållet. Sortera skruvar enligt instruktionen. Montera möbeln efter nummerordning som visas enligt bilderna. Om det fattas något, ring till affären.

Efter några veckor behövs eventuellt skruvar och bultar dras åt igen.

Denna möbel bör monteras på en mjuk och plan yta, för att förhindra uppkomst av skador.

WICHTIG

Lesen Sie sich die Anleitung aufmerksam durch, bevor Sie mit der Montage beginnen. Überprüfen Sie, ob alle Teile vorhanden sind. Sortieren Sie die Schrauben entsprechend der Anleitung. Das Möbelstück wird in der Reihenfolge der angegebenen Abbildungen montiert. Sollten Teile fehlen, dann informieren Sie bitte das Geschäft, in dem Sie das Möbelstück gekauft haben. Nach einigen Wochen müssen Schrauben und Bolzen eventuell etwas nachgezogen werden.

Dieses Möbel soll auf einer weichen Unterlage montiert werden, um Schäden zu vermeiden

IMPORTANT











Read the notice before you start. Check the contents. Sort the screws As per instructions. assemble the piece of furniture in number order as shown in the pictures. If there is anything missing, phone the shop. After a few weeks, the screw and bolts may need tightening up again.

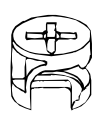

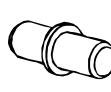
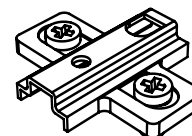
This unit should be assembled on a soft, flat surface to prevent any damage.

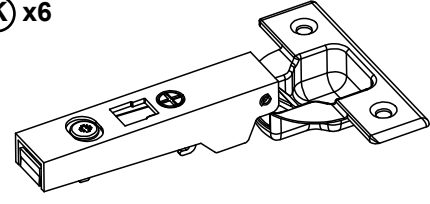
IMPORTANT

Lire la notice avant de commencer. Vérifier le contenu. Trier les vis conformément aux instructions. Monter le meuble selon l'ordre Indique par les images. Si quelque chose devait manquer, téléphoner au magasin. Après quelques semaines, il est éventuellement nécessaire de resserrer les vis et les boulons.

Afin d'éviter tout dommage, ce meuble doit être monté sur une surface plane.

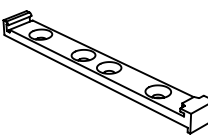
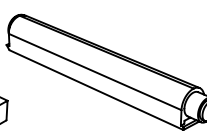
(A) x16 3200000639  30 mm	(B) x28 3300001093 	(C) x20 3300000193 	(D) x12 3300002193 	(E) x48 3100054093 	
(G) x24 3100002793 	(H) x12 3200000193 	(I) x6 3250005693 	(J) x12 3100000293 	(K) x6 3250005493 	
(L) x8 3100000993 	(M) x2 3200000339  50 mm	(N) x2 3300002493 			

(O) x3 3250005793 	(P) x3 	(Q) x3 	(R) x12 
---	---	---	--



Före montering se till att ha dessa verktygen.

Before assembly make sure that you have these tools.

Vor der Montage ist darauf zu achten dass diesen Werkzeuge vorhande sind.

Avant montage, veuillez vous assurer que vous avez ces outils.

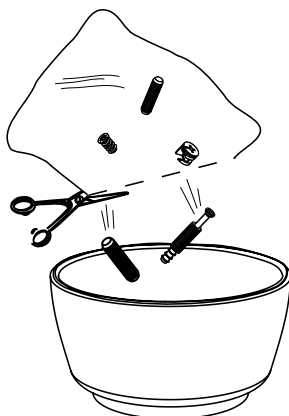
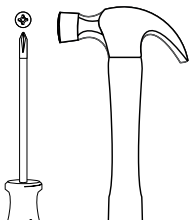

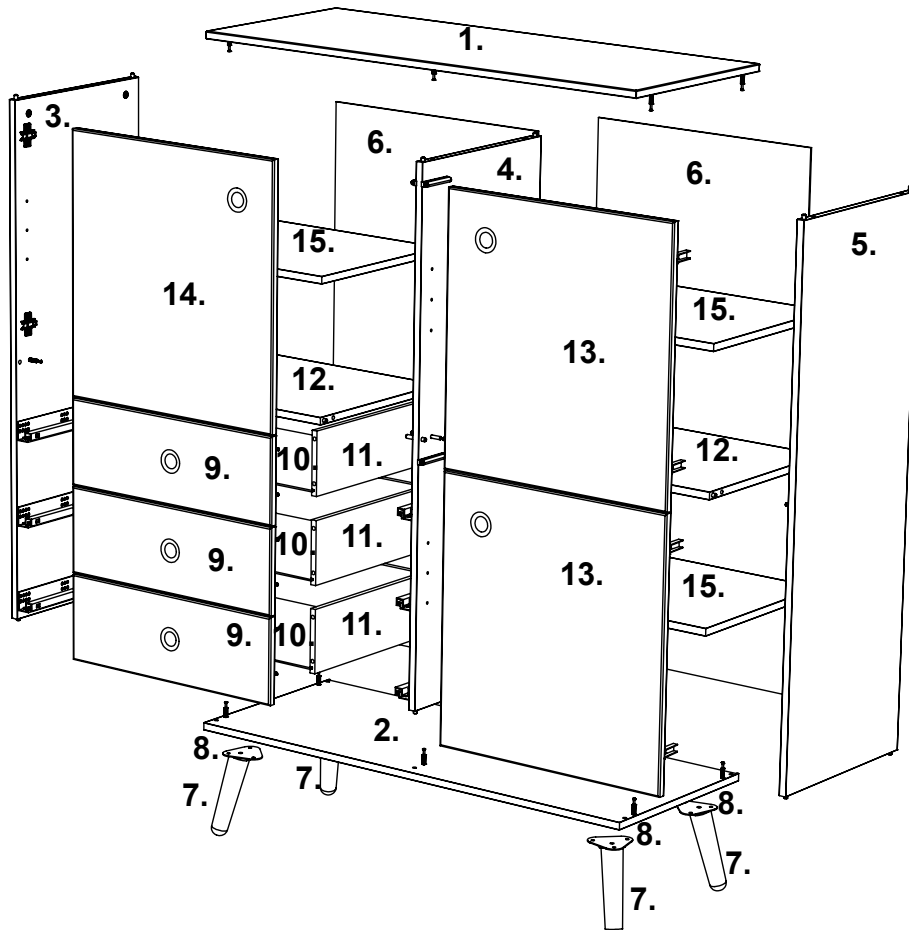

16.x6

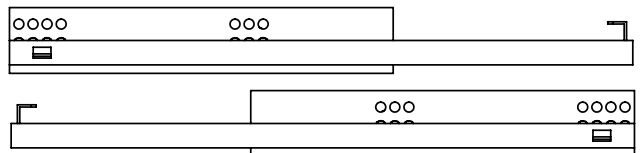

1.

G x12

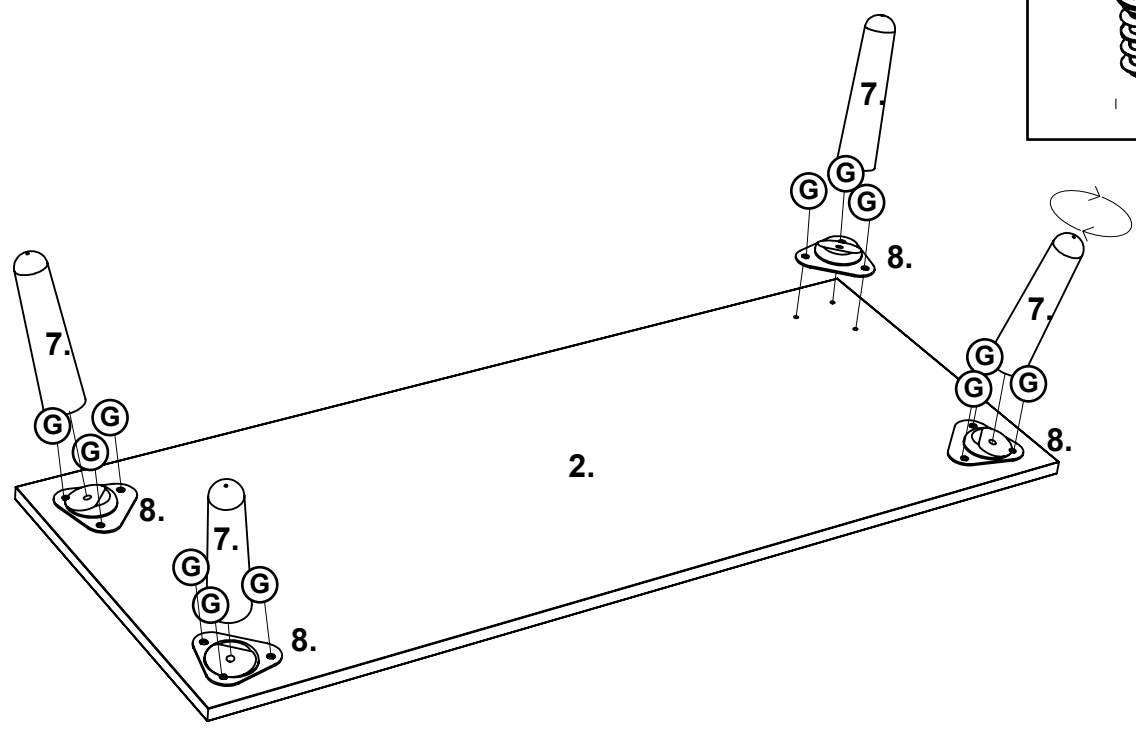

2.

B x12

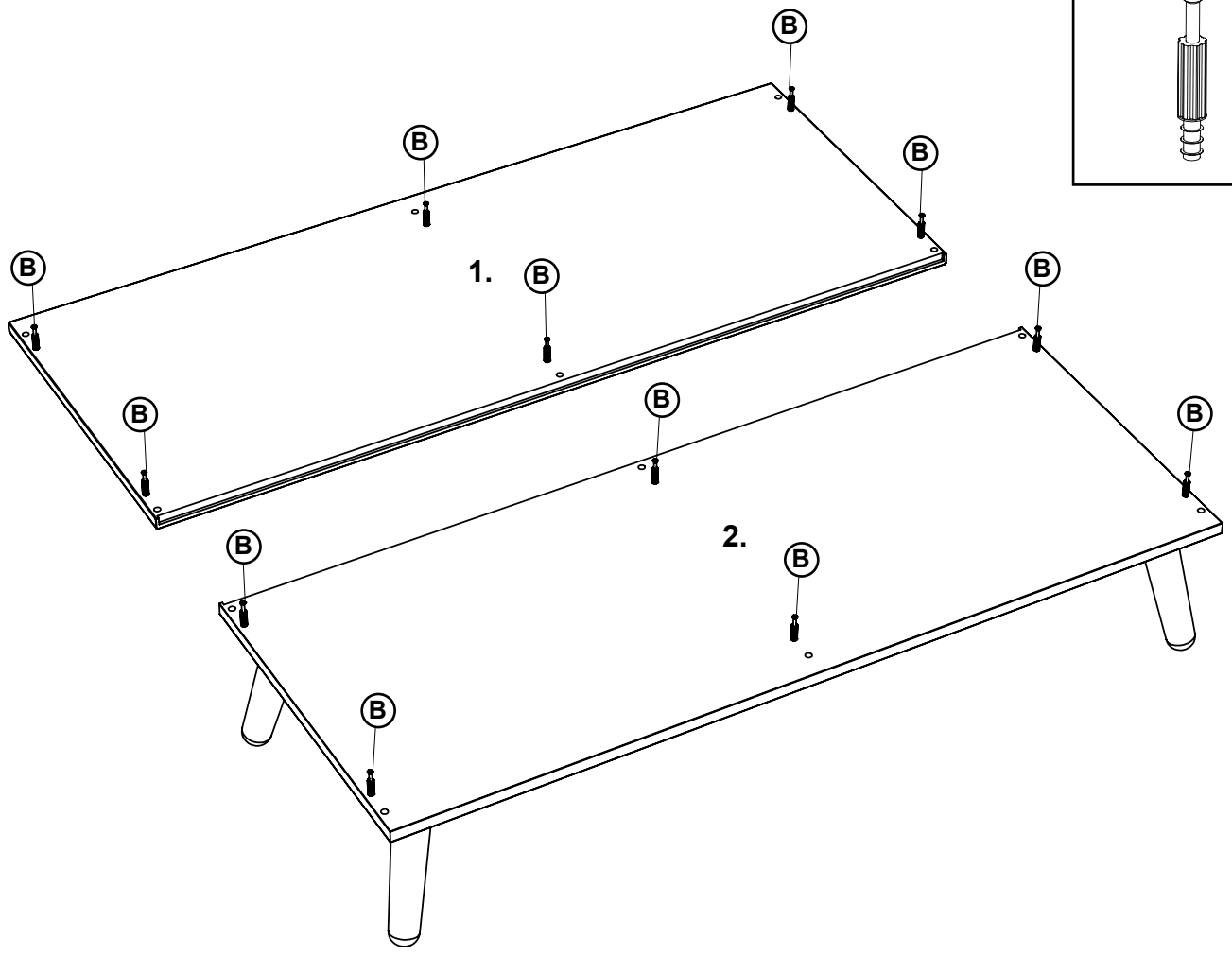
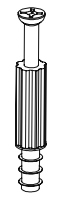

3.

A x12

B x4

C x12

G x8

I x6

O x3

P x3

R x9

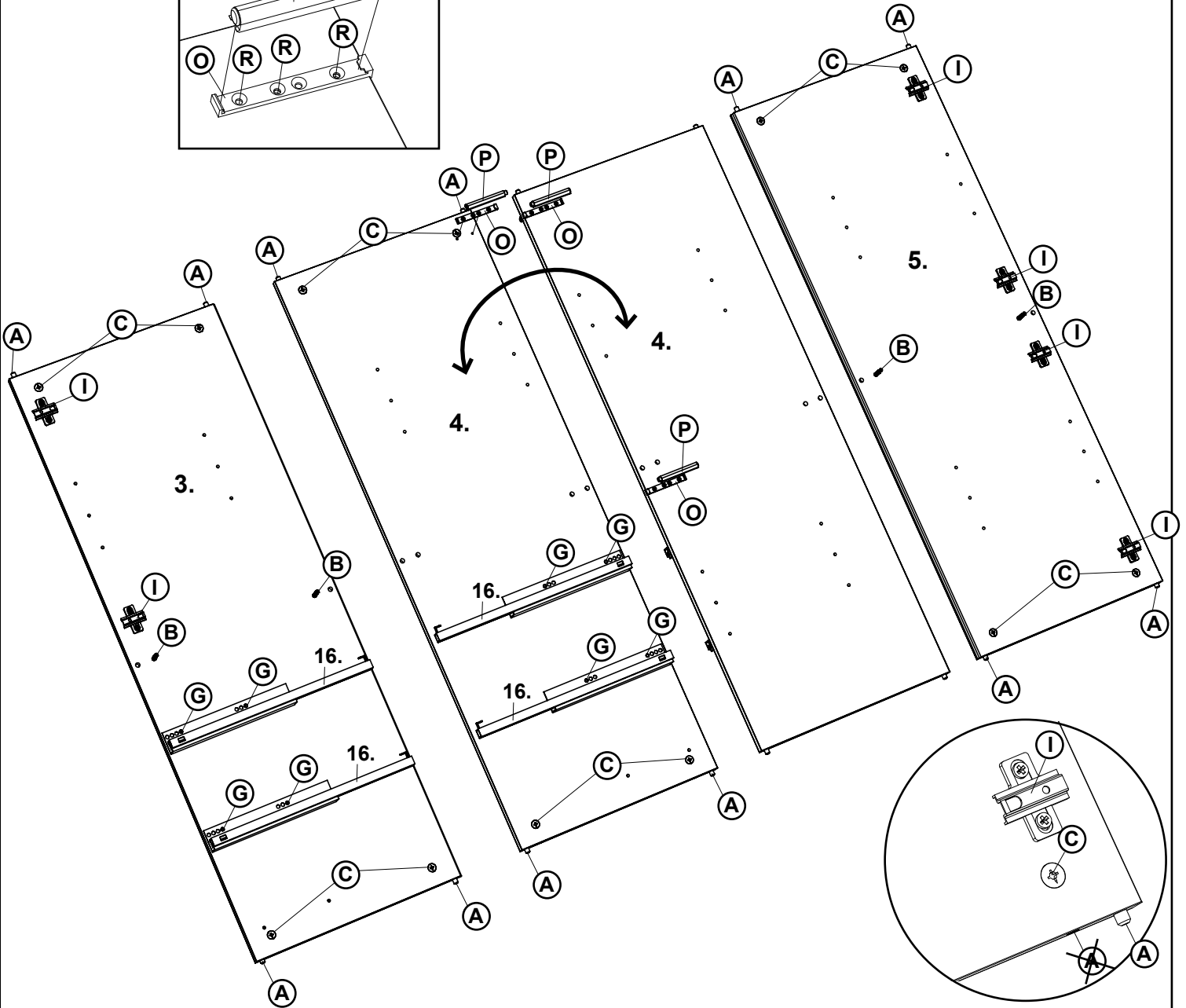
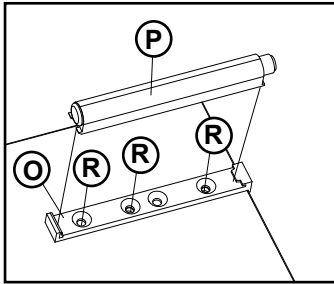
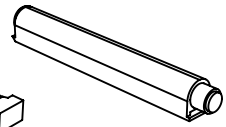
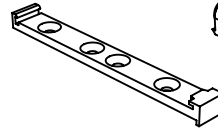
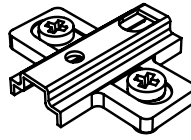
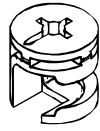
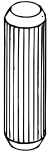

16.

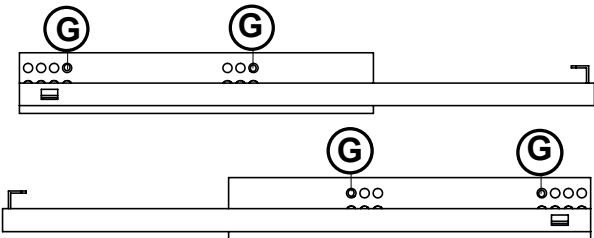

4.

C x8

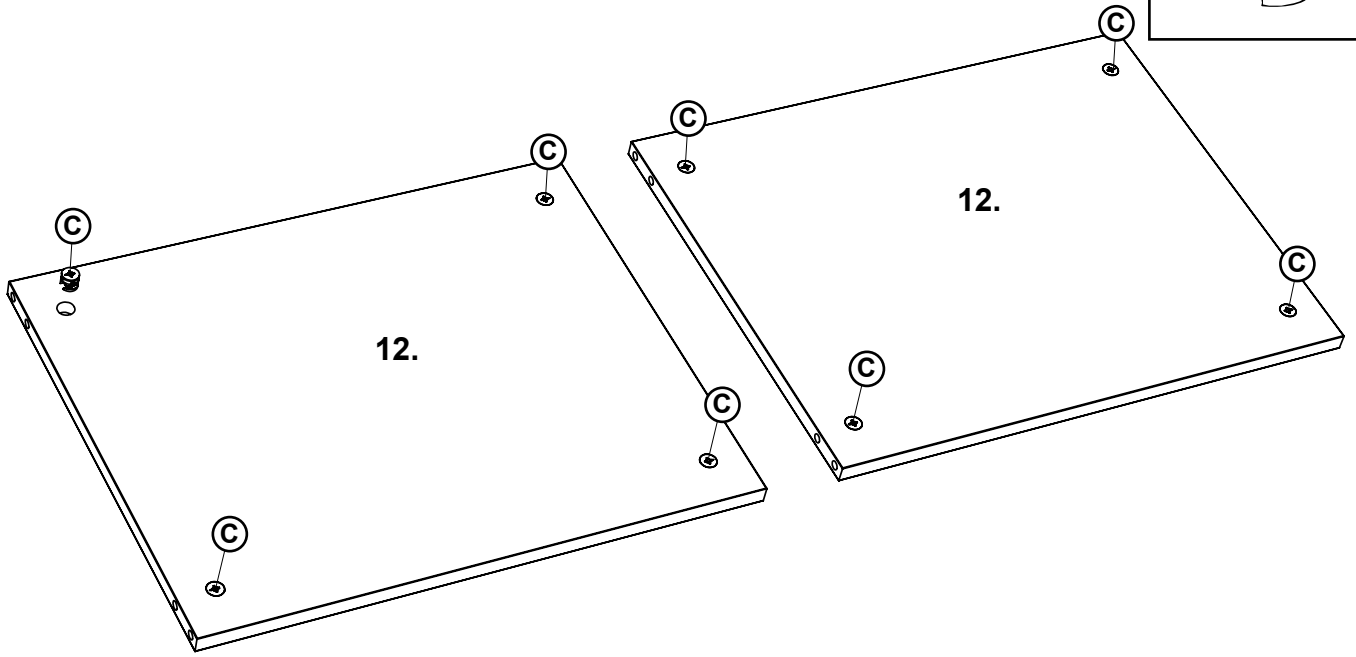
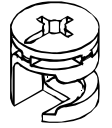

5.

A x4

M x2

N x2



30 mm



50 mm

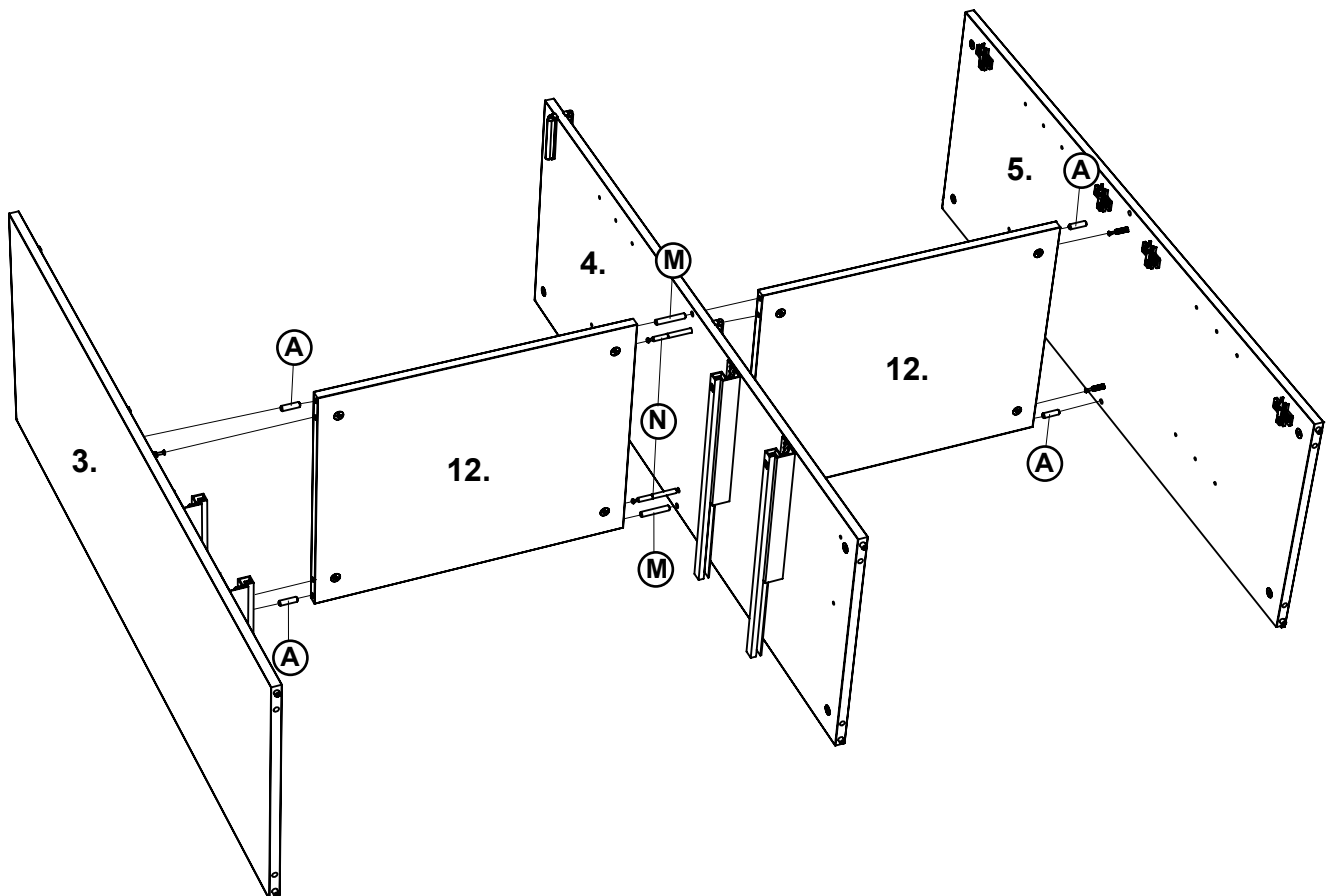
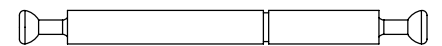

6.

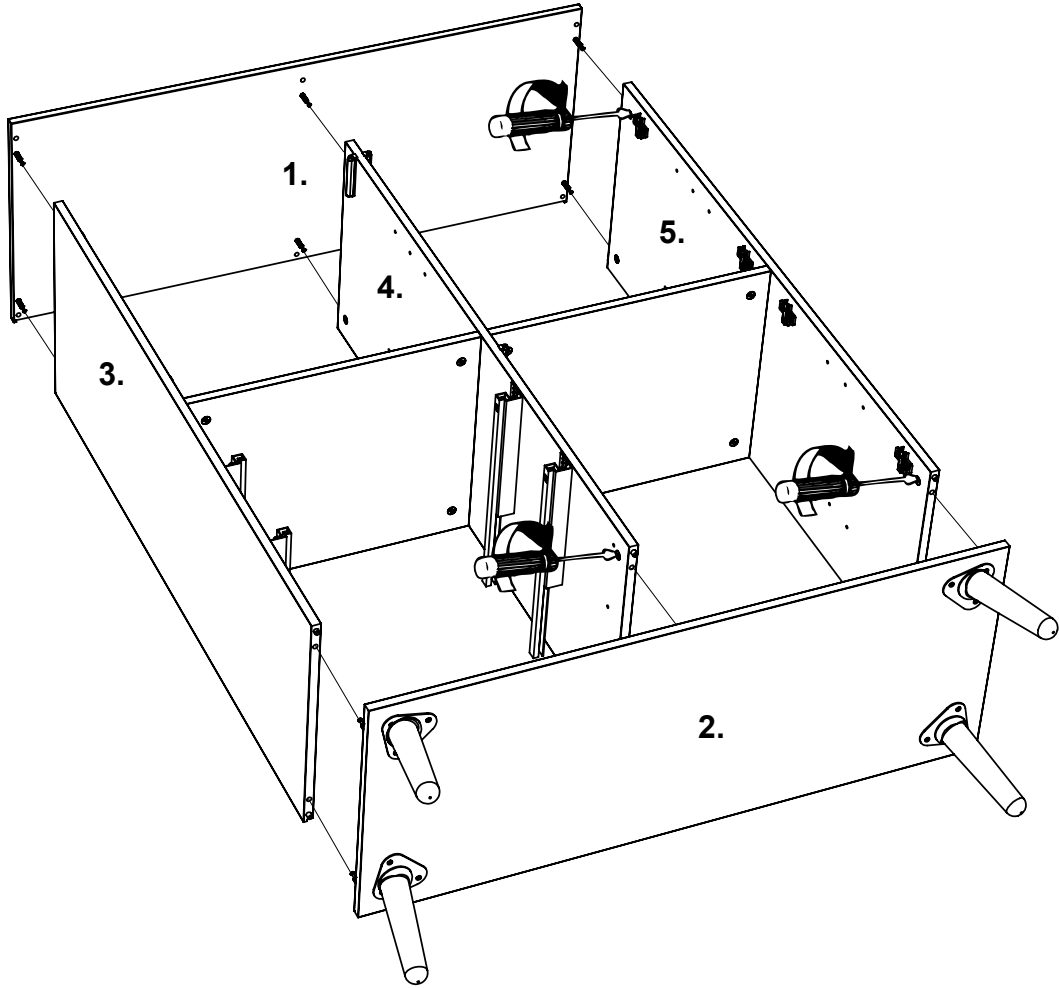

7.

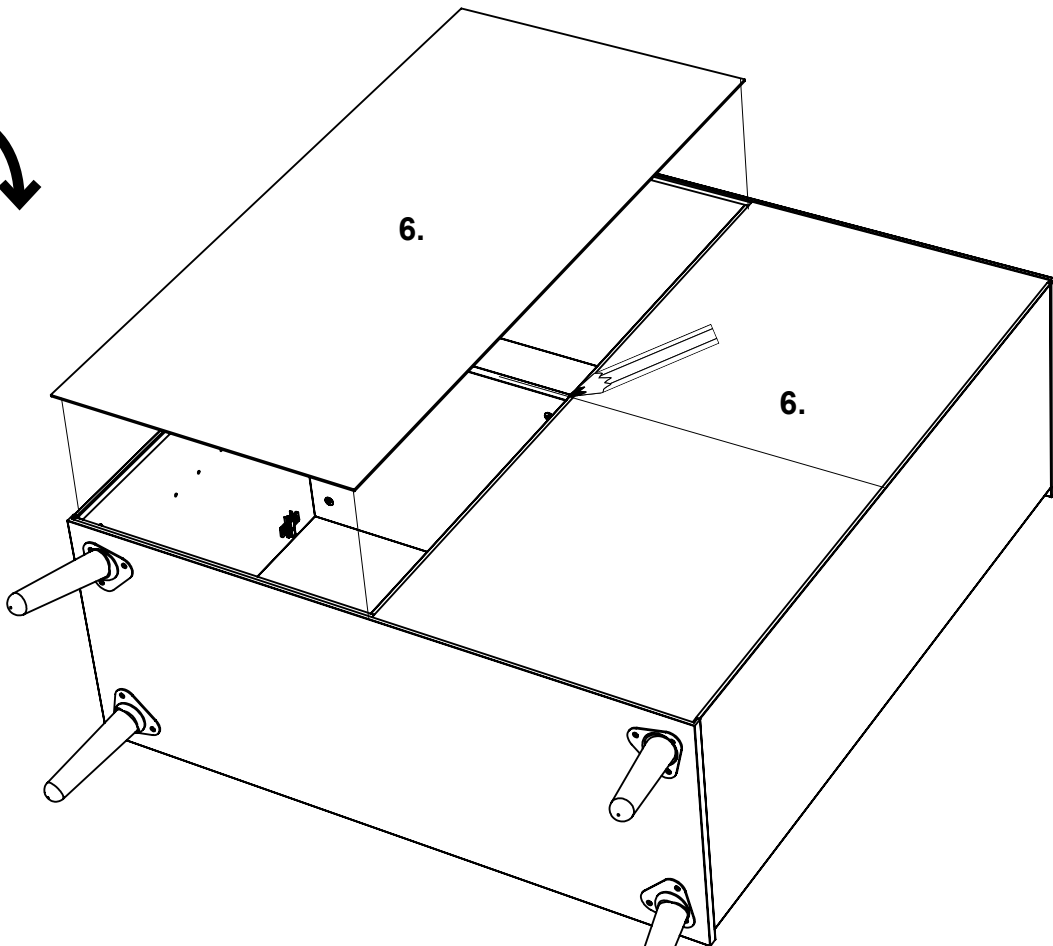

8.

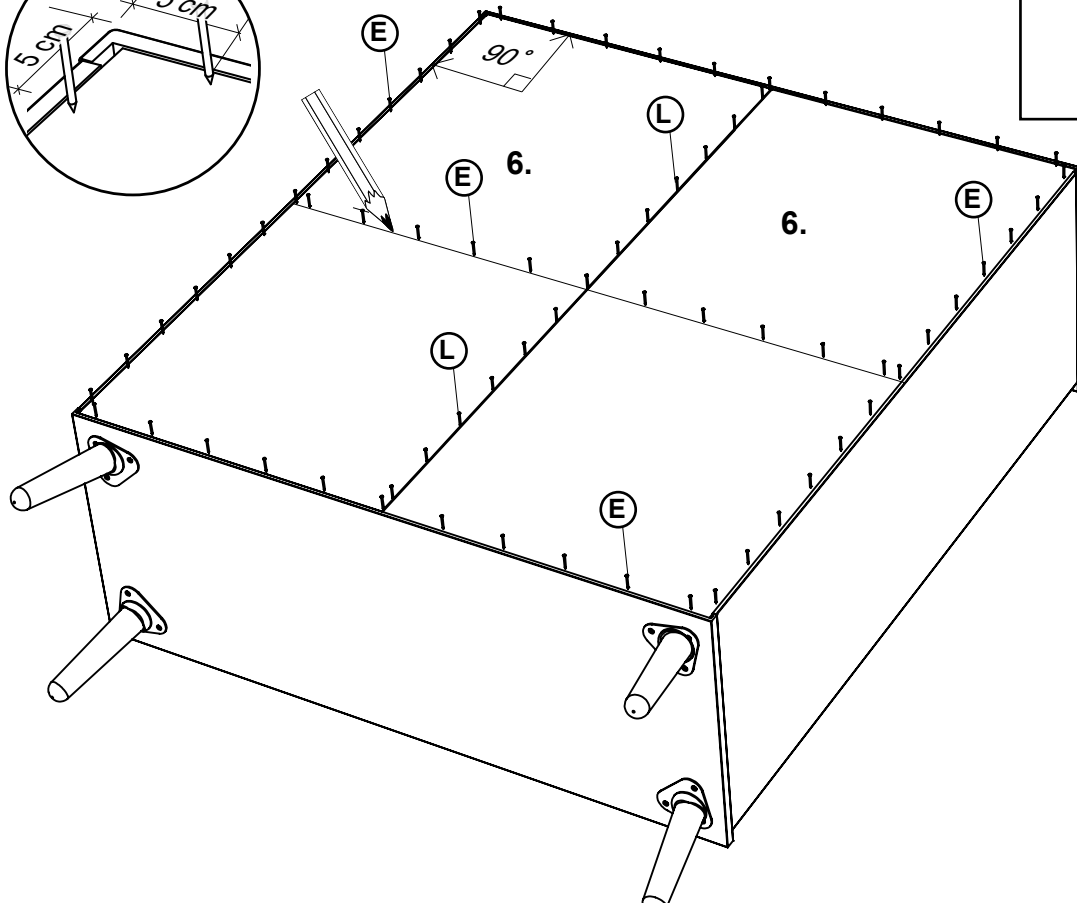
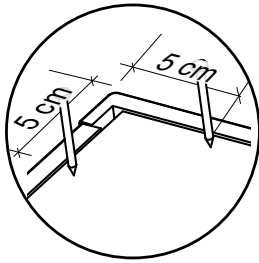

(E) x48

(L) x8



9.

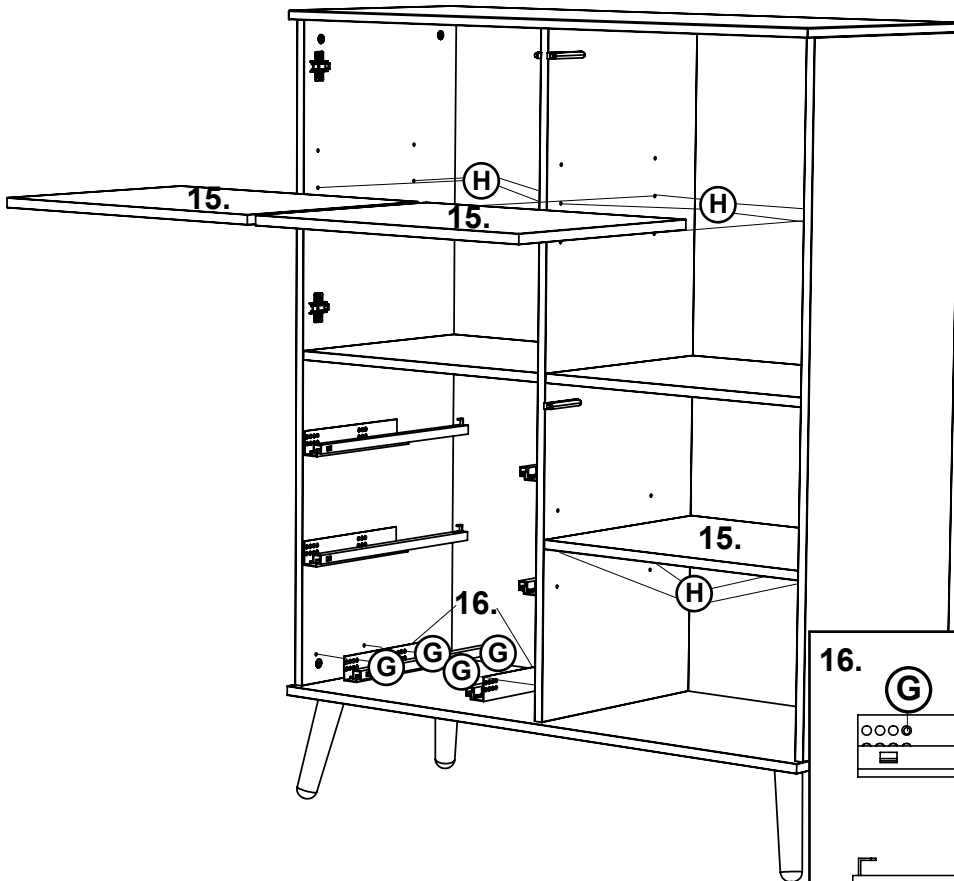

(G) x4

(H) x12

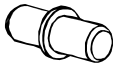

16.

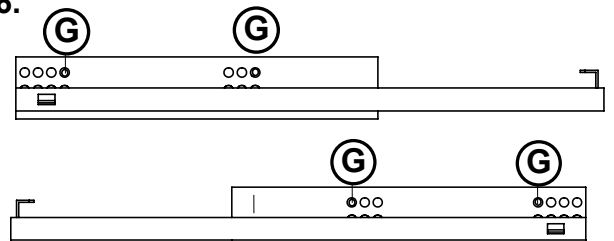

10. (x3)

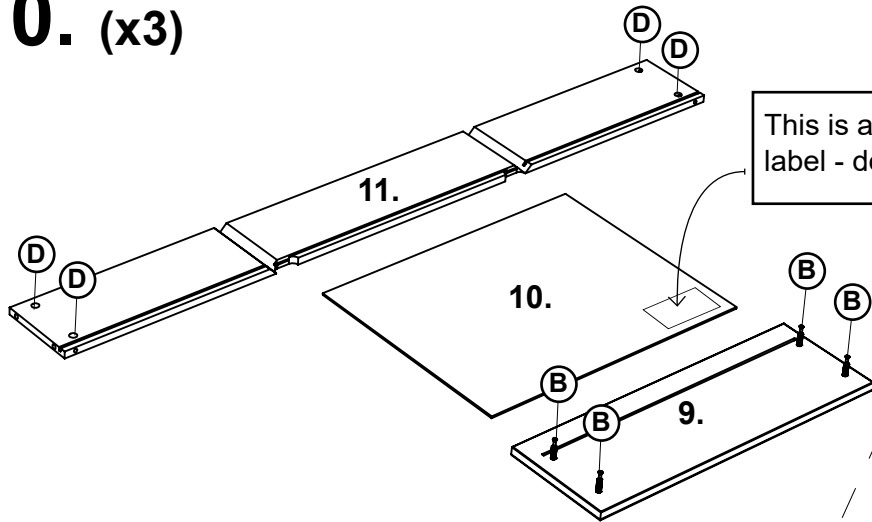

(B) x12

(D) x12



This is a permanent label - do not remove

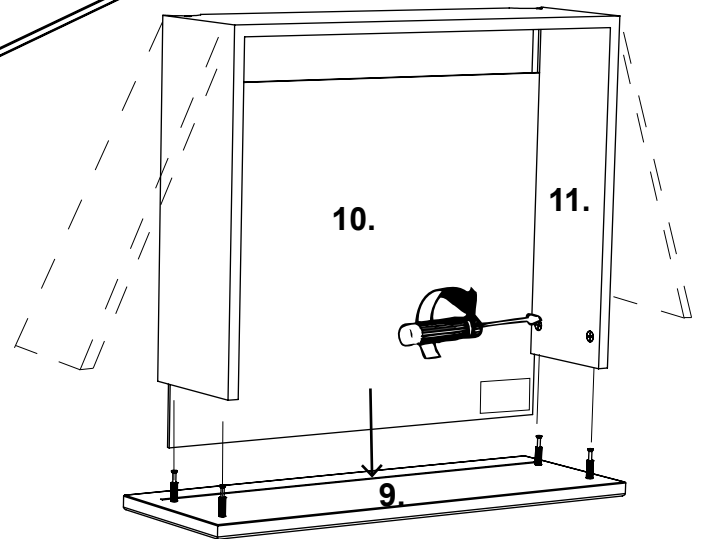

11.

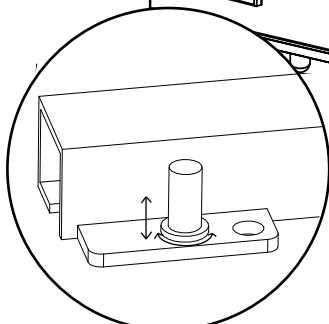
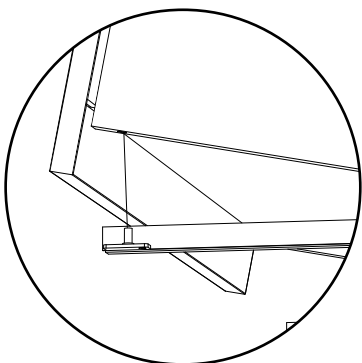
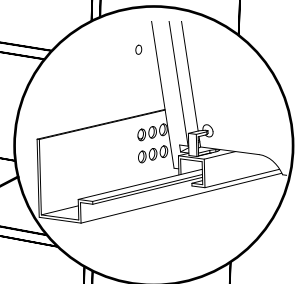
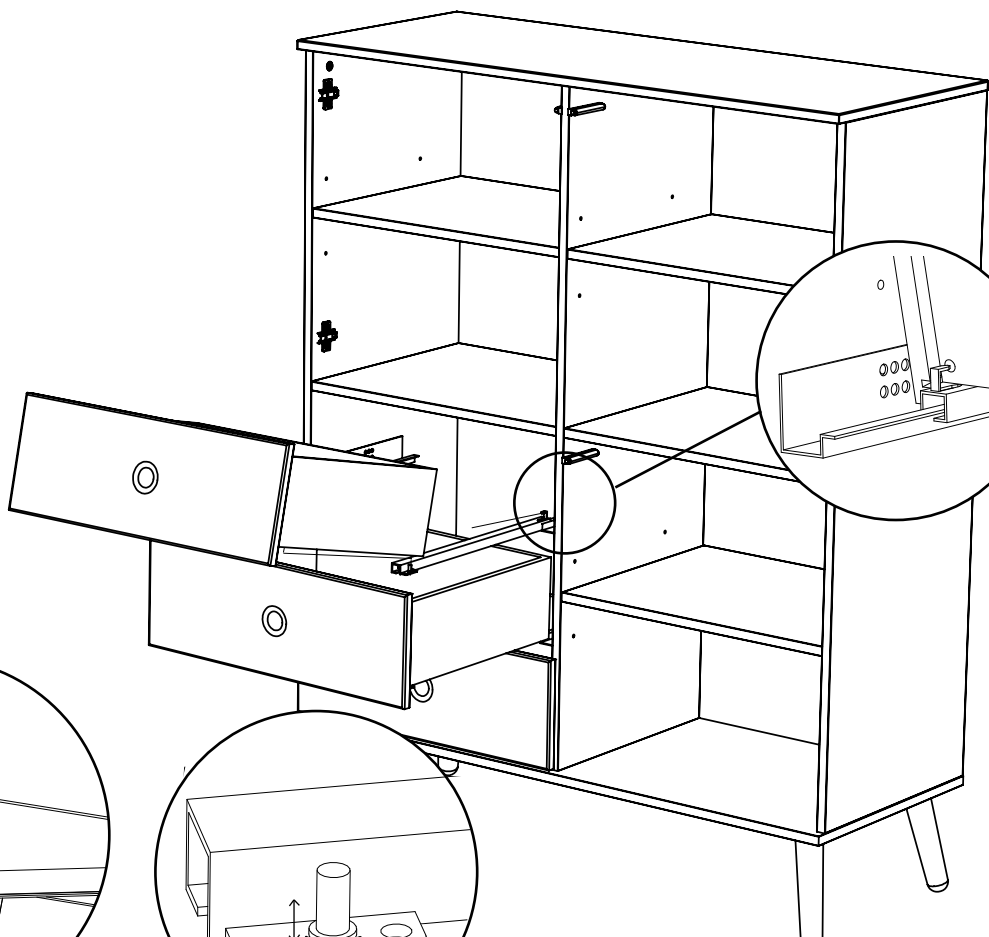

12.

(K) x6

(J) x12

(Q) x3

(R) x3

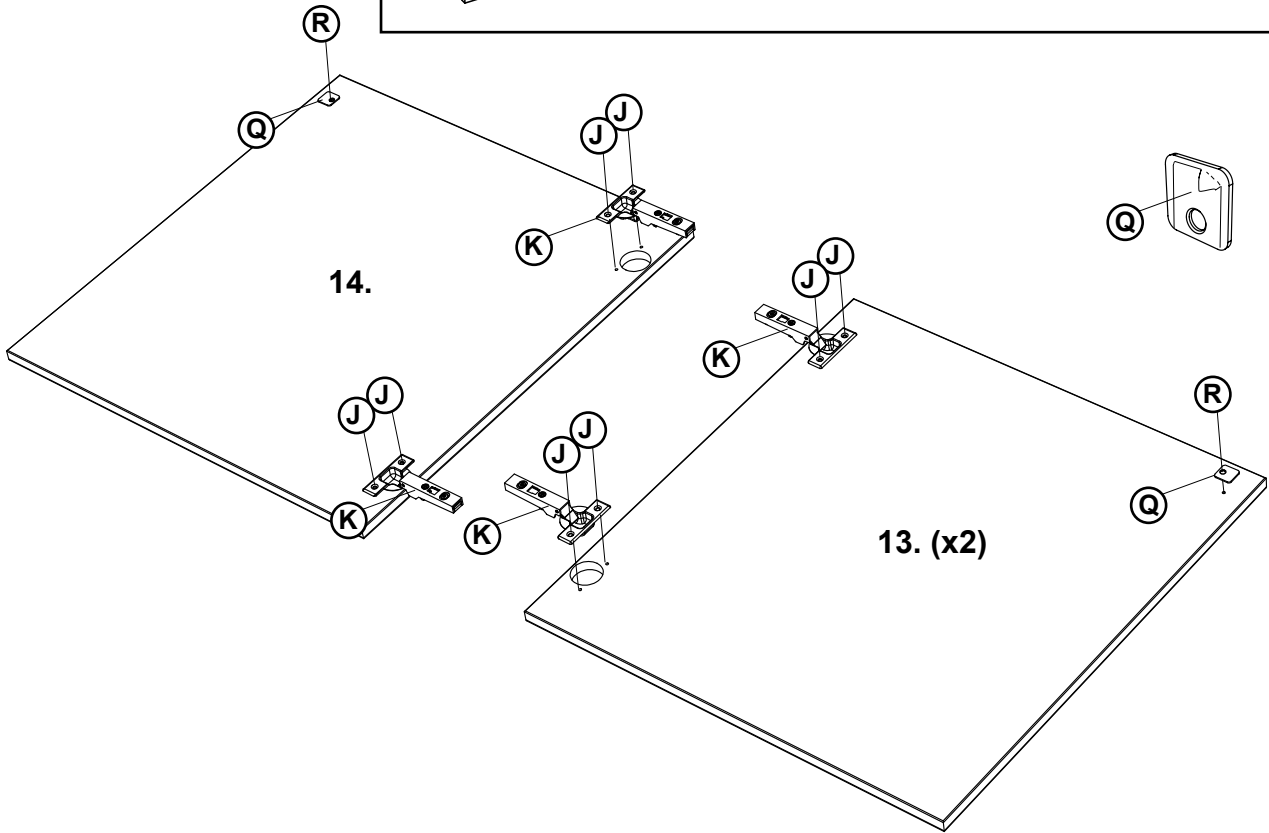
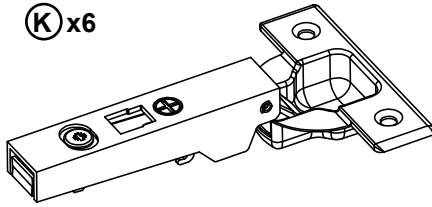

13.

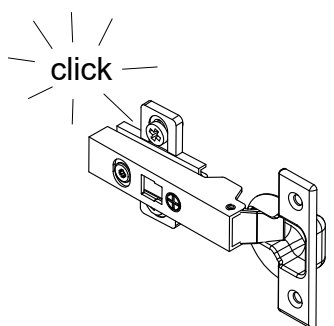
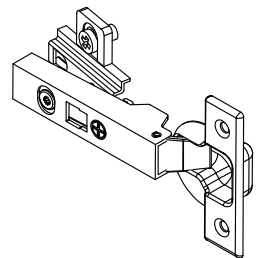
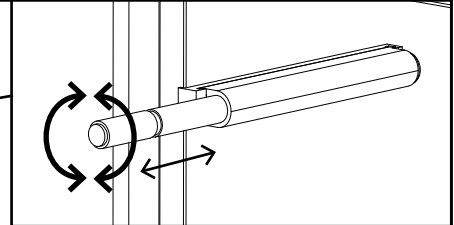
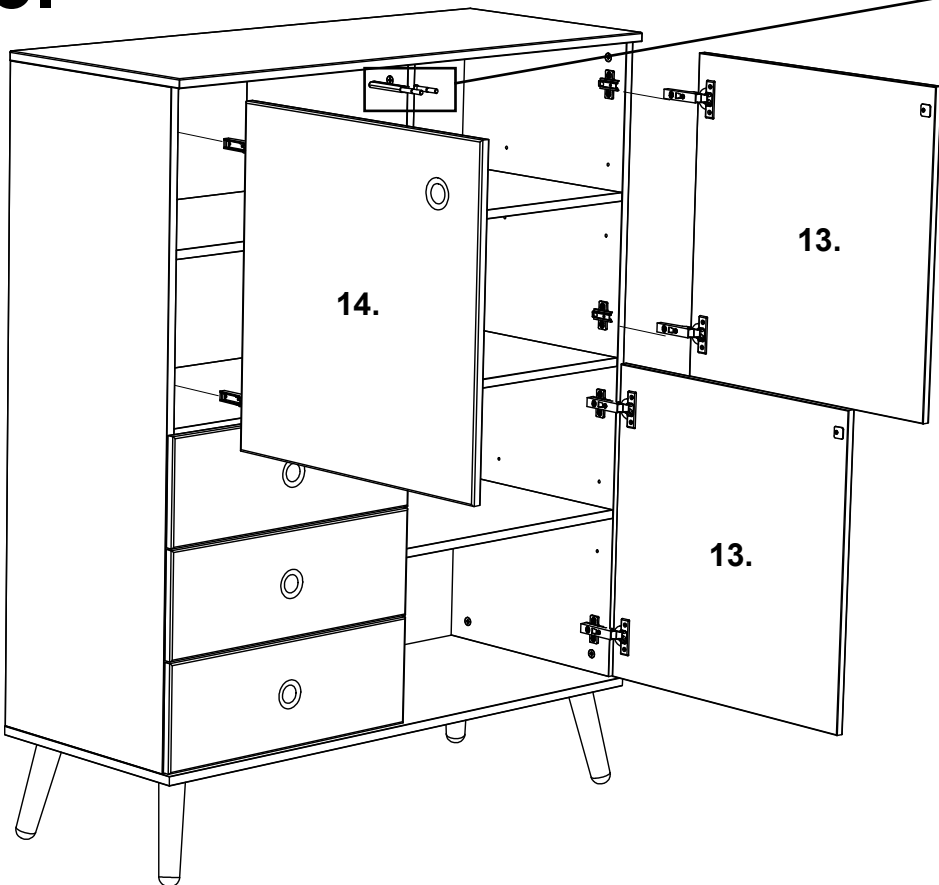

14.

FURNITURE ANTI-TIP KIT



⚠ WARNING

Serious or fatal crushing injuries can occur from furniture tipover. To help prevent tipover:

- Install tipover restraint provided.
- Place heaviest items in the lower drawers
- Unless specifically designed to accommodate,, do not set TVs or other heavy objects on top of this product.
- Never allow children to climb or hang on drawers, doors or shelves.
- Never open more than one drawer at a time (OR)
- Do not defeat or remove the drawer interlock system.



Use of tipover restraints may only reduce, but not eliminate, the risk of tipover.

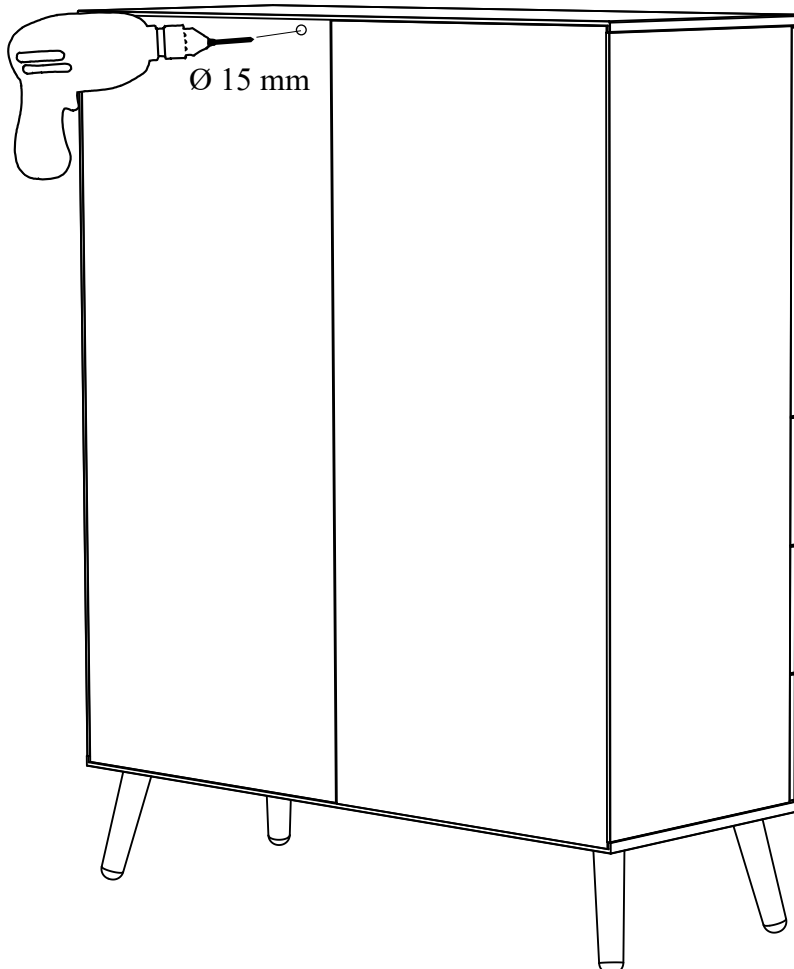
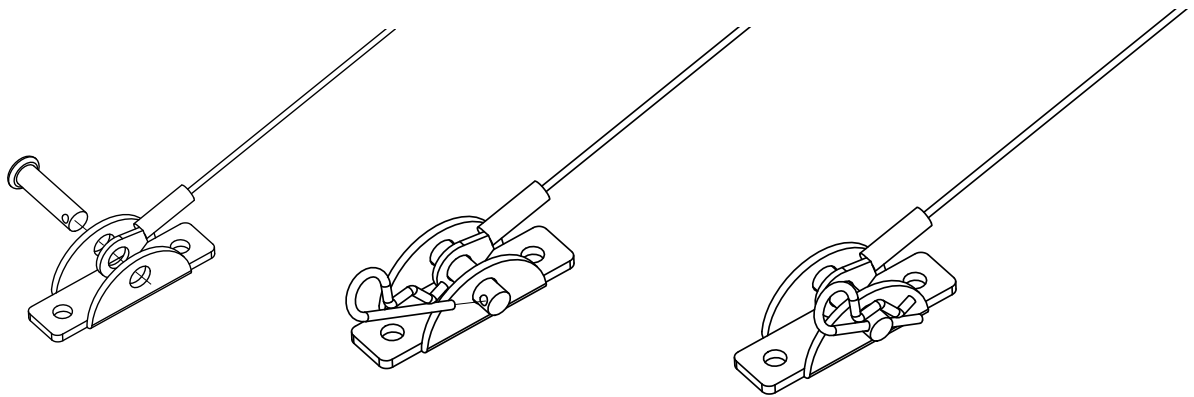

15.

Do **not** attach the product to the backpanel of the furniture

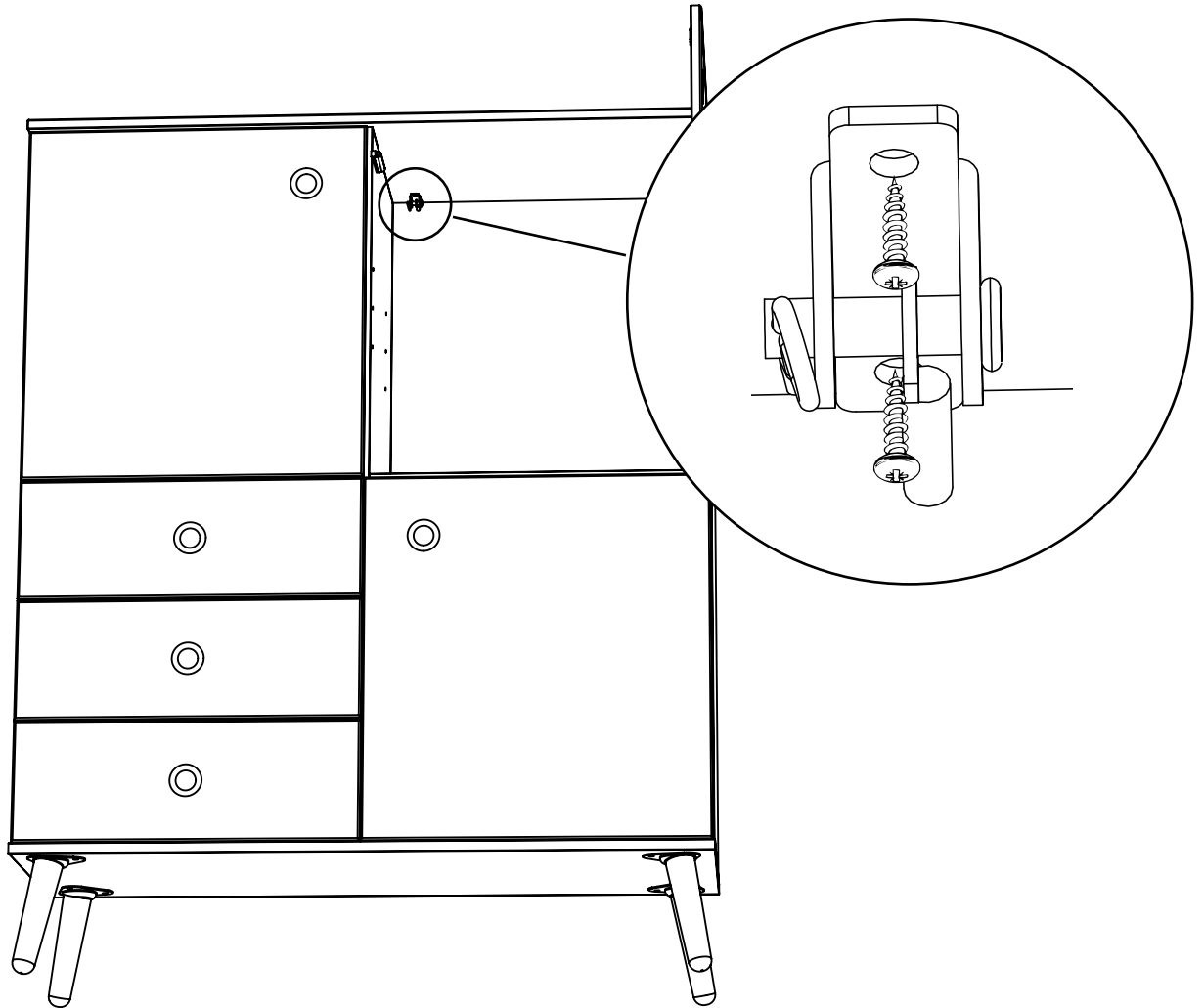

16.

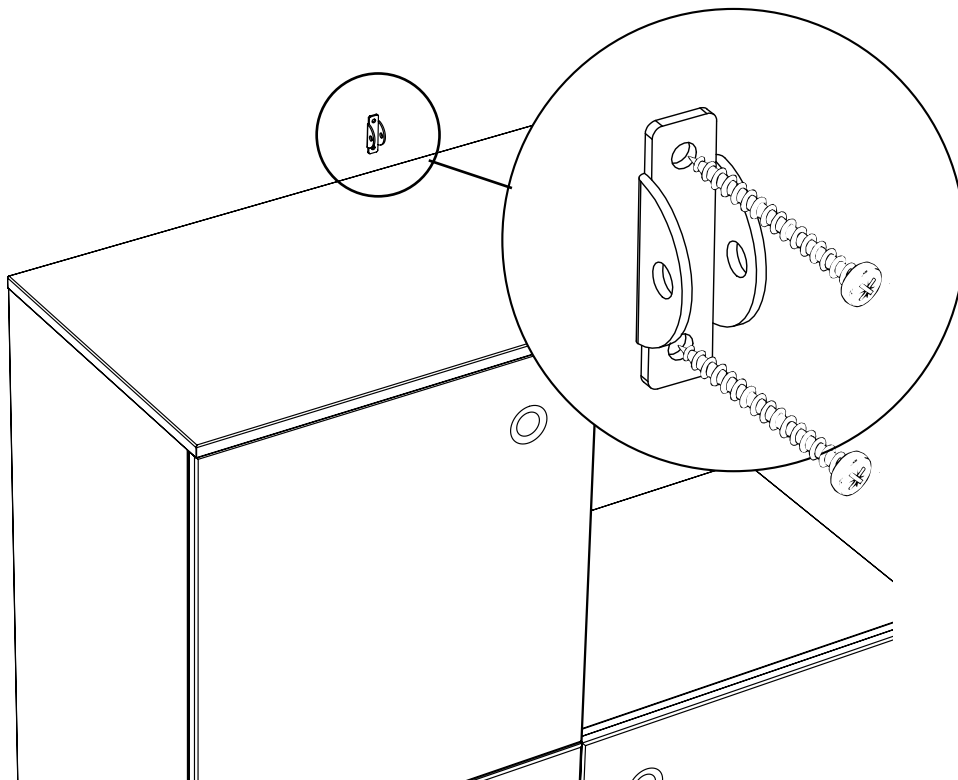

Before attaching the product to the wall, Please ensure the wall is suitable for attachment of this kind of product. Please use suitable Dowels and screws for your wall.

Es muß sichergestellt sein, daß die Wand für die Montage geeignet ist. Bitte prüfen Sie vor der Montage gründlich den Zustand der Wand. Bitte benutzen Sie einen für Ihre Wand geeigneten Dübel und Schraube

L'installation doit être réalisée par une personne compétente qui s'assurera de l'adéquation entre le dispositif de fixation et le mur. Prend s.v.p. des chevilles et vis convenables au mur

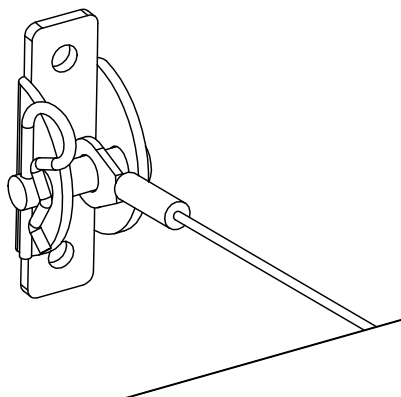
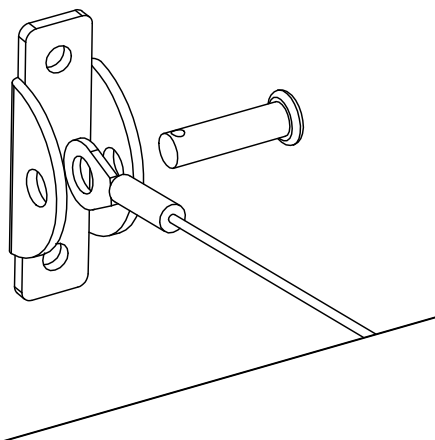

17.

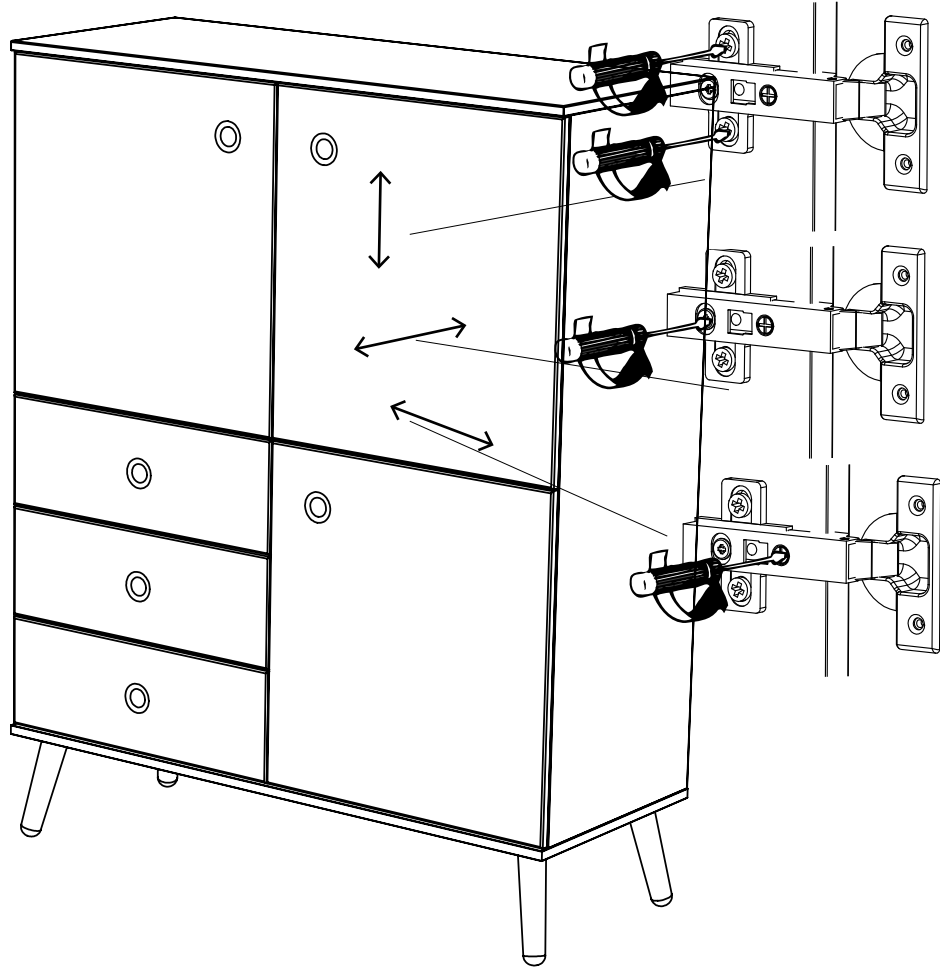

Råd för skötsel och underhåll

För att skydda ditt golv bör produkten kompletteras med filttassar. Möbeln är avsedd för inomhusbruk. Ställ aldrig möbeln på fuktigt underlag eller i direkt solljus. Var försiktig med vilka föremål du placerar på möbeln då det kan orsaka skador så som repor och missfärgningar. För underhåll eller borttagning av eventuell smuts eller märken, använd en trasa med vatten och tvål. Eftertorka med en mjuk torr trasa. För svårare fläckar kontakta din återförsäljare eller fackman.

Advice on care and maintenance

To protect your floor, you should fit felt pads to the product. This item of furniture is designed for use indoors. Never stand the furniture item on a damp surface or in direct sunlight. Be careful about what you stand on your furniture, as some items can cause damage in the form of scratches or discoloration. To maintain the furniture or remove any dirt or marks, use a cloth with soap and water. Dry off with a soft dry cloth. For more difficult stains, contact your dealer or specialist.

Pflegehinweise

Um Ihren Boden zu schonen, versehen Sie das Produkt am besten mit Filzgleitern.

Das Möbelstück ist für den Einsatz im Innenbereich vorgesehen. Achten Sie darauf, dass das Möbelstück nicht auf einer feuchten Unterlage steht und keiner direkten Sonneneinstrahlung ausgesetzt ist. Vorsicht beim Platzieren von Gegenständen auf dem Möbelstück: Diese könnten Kratzer, Verfärbungen oder andere Schäden verursachen. Benutzen Sie zum Pflegen und zum Entfernen von Verunreinigungen oder Flecken ein Tuch, das Sie in Wasser mit leicht seifigem Zusatz leicht angefeuchtet haben. Mit einem trockenen weichen Tuch nachwischen. Wenden Sie sich bei hartnäckigen Flecken bitte an Ihren Händler oder einen anderen Fachmann.

Conseils d'entretien

Pour protéger votre parquet, il est conseillé de poser des patins en feutre. Ce meuble est destiné à être utilisé à l'intérieur. N'installez jamais le meuble sur un support humide et ne l'exposez pas au rayonnement solaire direct. Veillez à ne poser sur le meuble aucun objet qui pourrait le rayer ou le décolorer, par exemple. Pour l'entretien ou l'élimination de taches ou traces éventuelles, utilisez un chiffon avec de l'eau et du savon. Séchez ensuite à l'aide d'un chiffon sec. Pour les taches difficiles, contactez votre revendeur ou un spécialiste.