

PLEASE NOTE: Check that you have received all components and hardware before assembling.

Assembly Instructions

Flat Low Back Office Chair

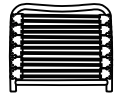

A (1 pc)



B (1 pc)

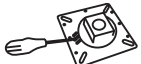

C (1 pc)



D (1 pc)



E (1 pc)



F (1 pc)



* see important note

G (4 pcs)
M8 x 14mm



H (2 pcs)
1/4" x 5/8"



I (1 pc)
5mm



J (1 pc)
4mm

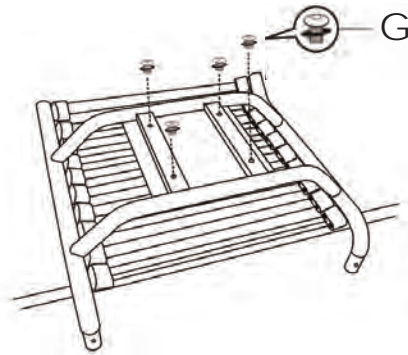

IMPORTANT NOTE:
Screws and washers (Parts G) are preassembled into the underside of the seat (Part B). Remove screws and washers from seat and then use to attach Part C to Part B, as shown in step 1.

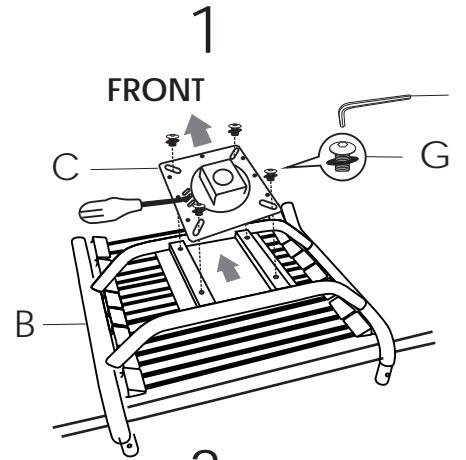

1

FRONT

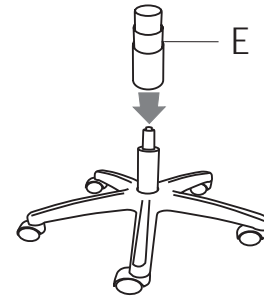

3

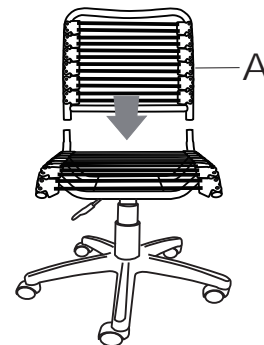

5

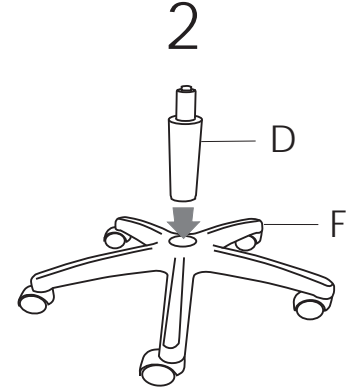

2

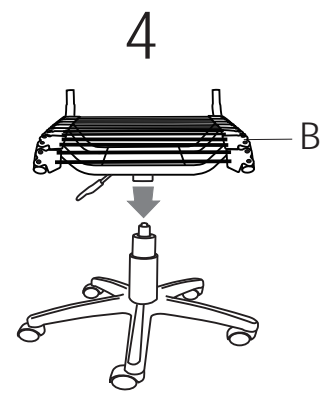

4

6

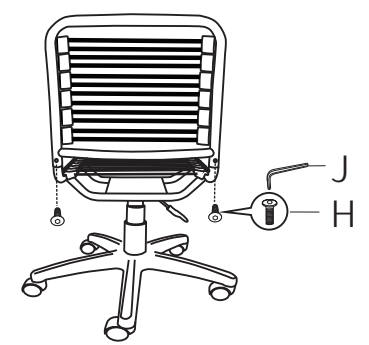

During assembly, hand tighten screws only. When the screws are in place, tighten completely.