

ASSEMBLY INSTRUCTIONS

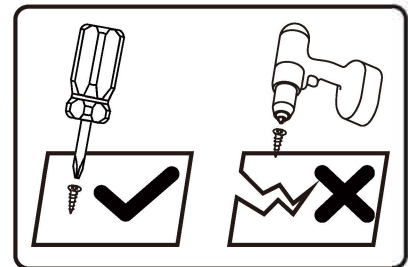
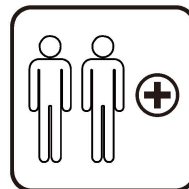
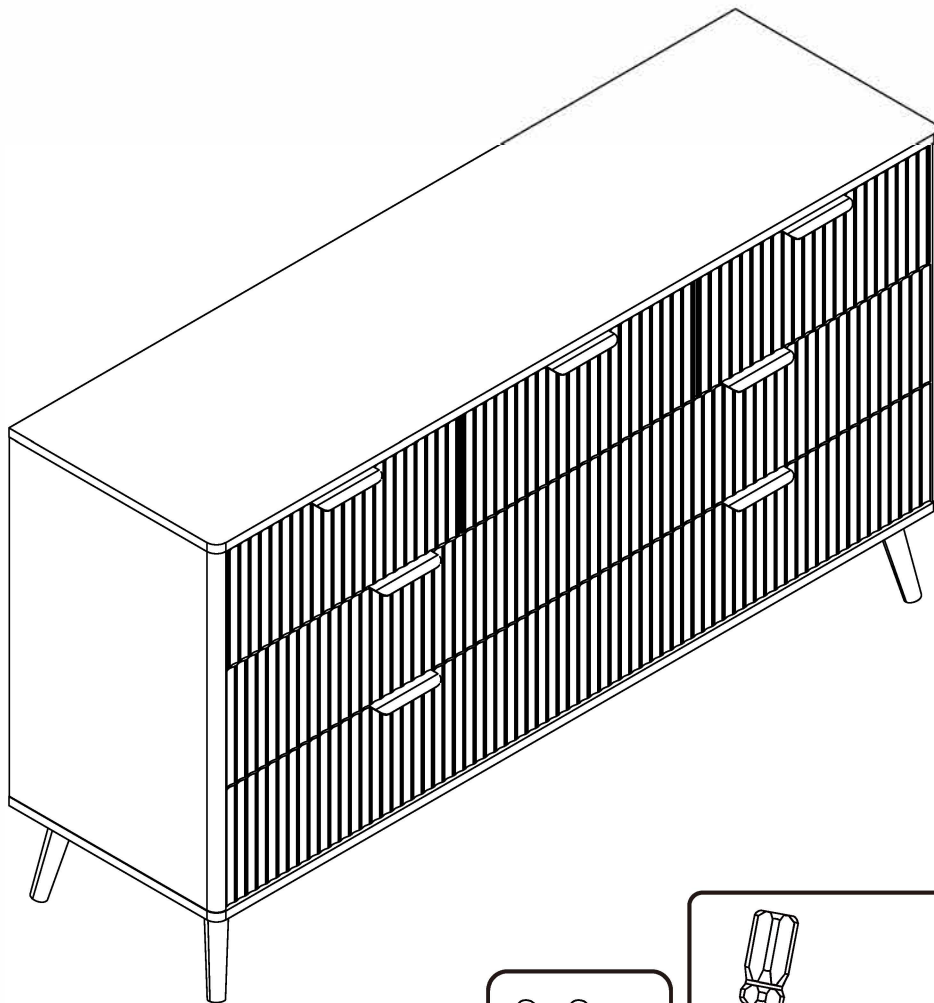

Tools Recommended

THIS INSTRUCTIONS CONTAINS IMPORTANT SAFETY INFORMATION.
PLEASE READ BEFORE ASSEMBLY AND KEEP FOR FUTURE REFERENCE.

Need Parts or Assistance?

IMPORTANT NOTICE



- This product contains small components, please ensure that they are kept away from small children.
- THIS INSTRUCTIONS CONTAINS IMPORTANT SAFETY INFORMATION. PLEASE READ BEFORE ASSEMBLY AND KEEP FOR FUTURE REFERENCE.
- Read each step carefully. It is very important that each step of instruction is performed in the correct order. If these steps are not followed in sequence, assembly difficulties will occur.
- Make sure all parts are included. Most parts are labelled or stamped on the raw edge.
- Work in spacious area, preferably on a carpet, near the place the unit will be used.
- Do not use power tools to assemble your furniture. Power tools may strip or damage the parts.
- Move your new furniture carefully, with two people lift and carry the unit to it's new location.
- Never push, drag or pull your furniture (especially on carpet)



PLEASE DO NOT RETURN PRODUCT TO US IMMEDIATELY









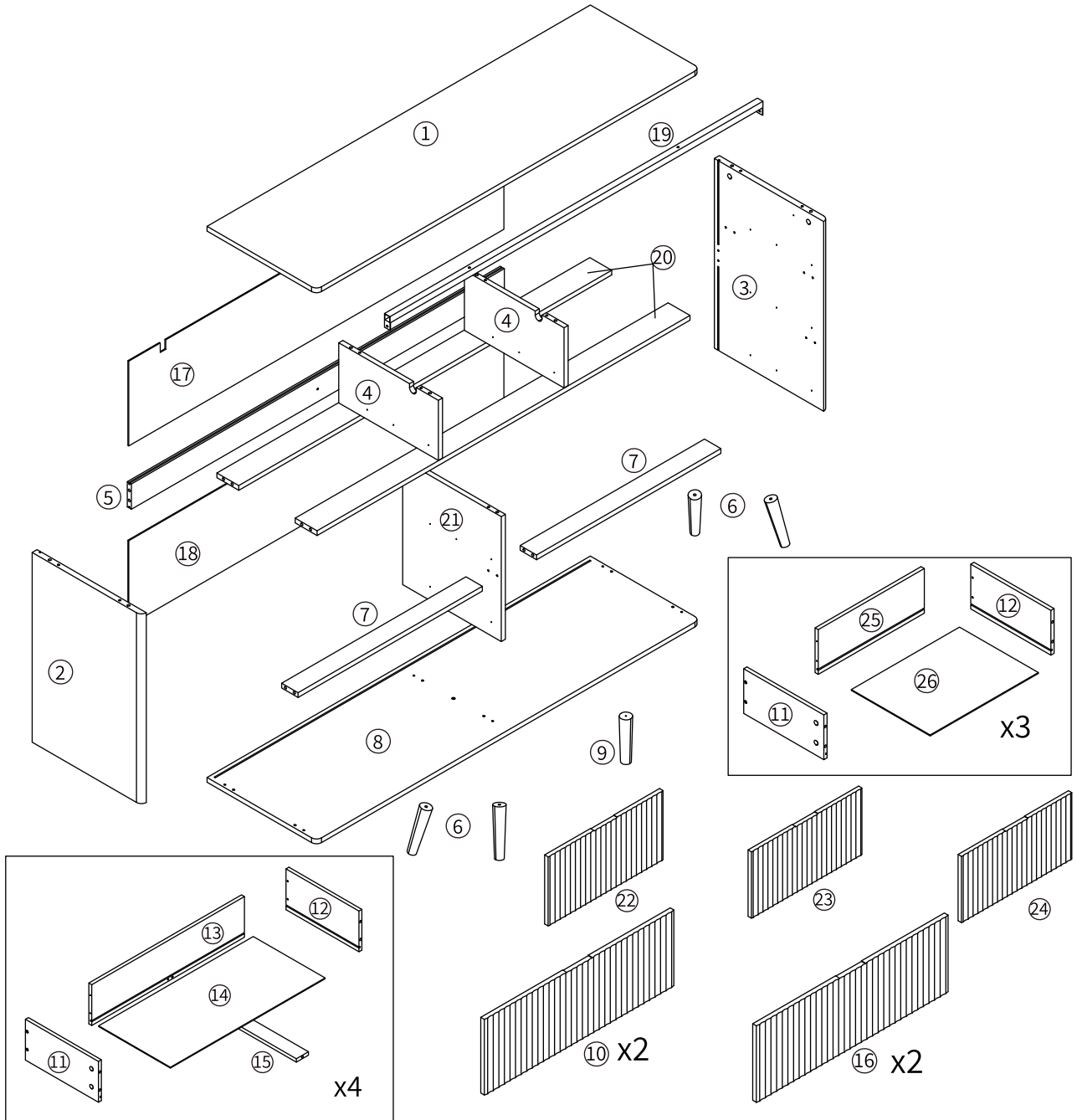













If a part is missing or damaged, email our customer service. We will gladly ship your replacement parts FREE of charge.

For Prompt, reliable service, please have your assemble instruction ready

 WARNING	
	Children have died from furniture tipover. To reduce the risk of furniture tipover: <ul style="list-style-type: none">- ALWAYS install Anti-tip device provided.- NEVER put a TV on this product.- NEVER allow children to stand, climb or hang on any drawers, doors, or shelves.- NEVER open more than one drawer at a time.- Place heaviest items in the lowest drawers.
	<p><i>This is a permanent label. Do not remove!</i></p>

The installation direction should be aligned with the instructions to prevent plate breakage caused by product tipping during installation.



A x62  6x35mm	B x62  6x30mm	C x20  4x40mm	D x12  4x35mm	E x7  3x12mm	F x14  3.5x12mm	G x16  3x14mm
H x16 	I x2 	J x24  4x14mm	K x2  4x30mm	L x2 	M x36  4x30mm	N x84  3.5x12mm
O x4 	P x1 	R x2  4x30mm	S x4 	CL x7 	CR x7 	DL x7 
DR x7 						

Step 1

Firstly lock the guide rail (CL) to the left side of the part ④x2 with screw (N), then turn it in 180 degrees and lock the guide rail (CR) to the right side of part ④x2, the installation position is as shown.

x2

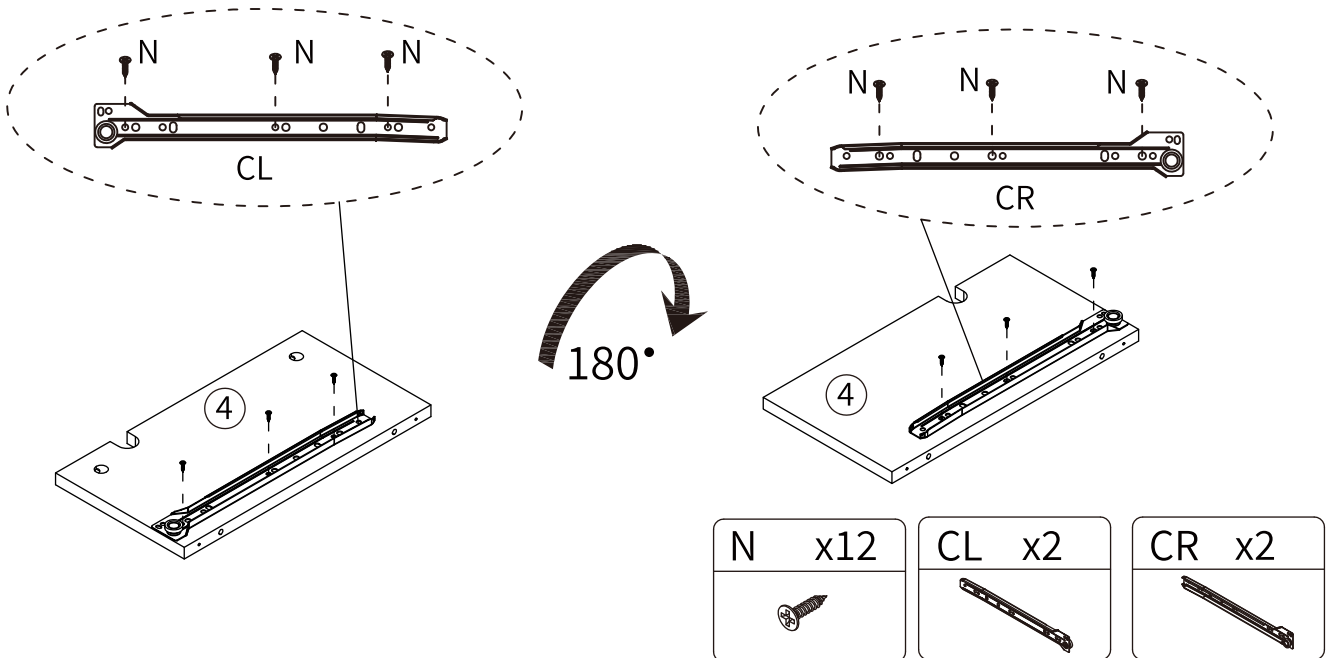

Step 2

Firstly lock the guide rail (CL) to the left side of the part ②1 with screw (N), then turn it in 180 degrees and lock the guide rail (CR) to the right side of part ②1. Insert the screw (A) on the right and left of part ②1, the installation position is as shown.

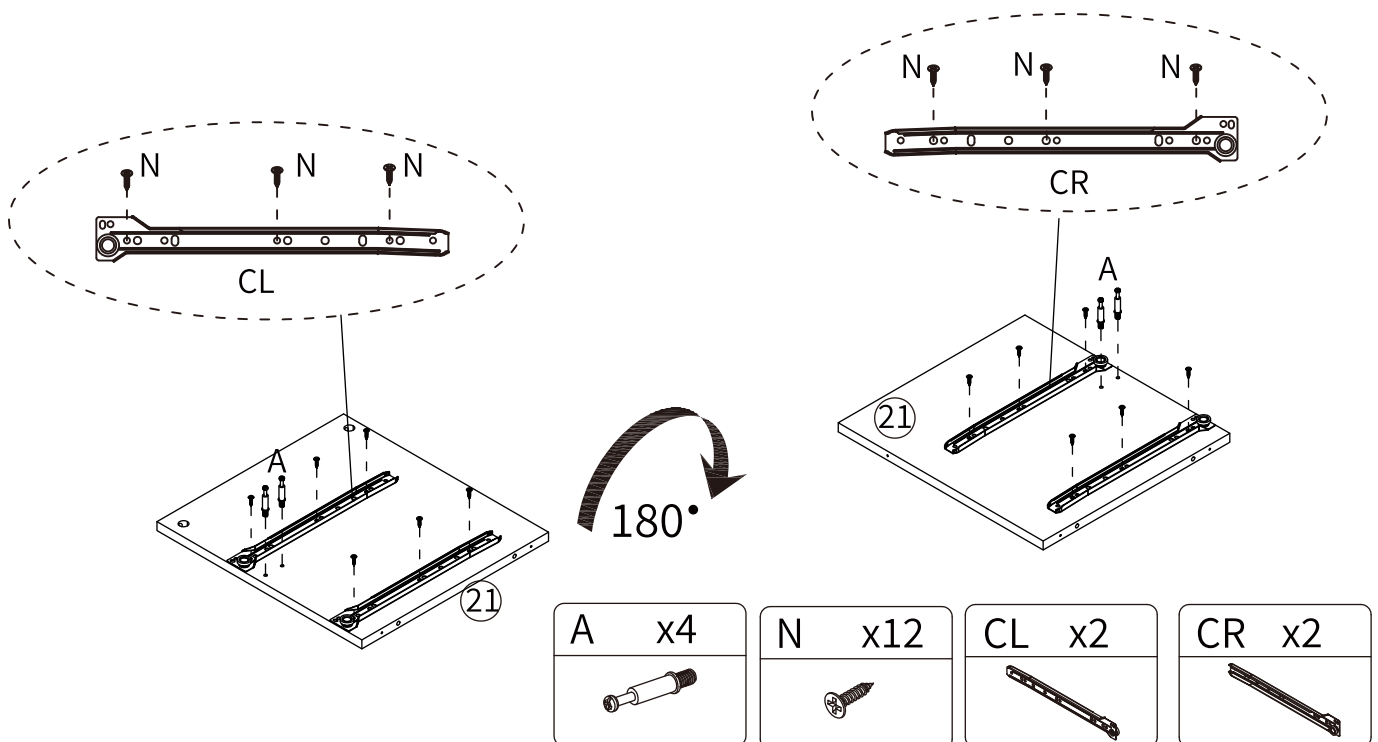

Step 3

Lock the guide rail (CL) to the part ② with screw (N) and lock the guide rail (CR) to the part ③ with screw (N), the installation position is as shown.

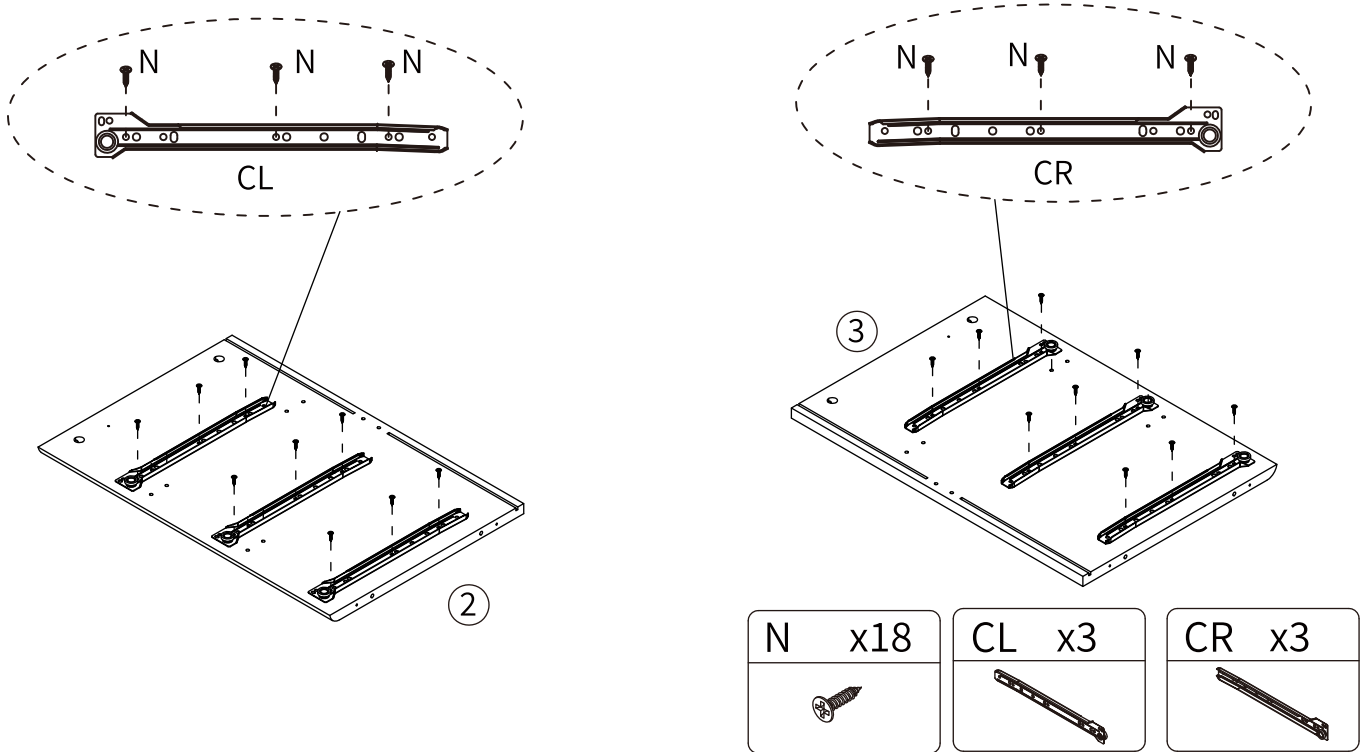

Step 4

Insert screw (A) into corresponding holes on part ② & ③.

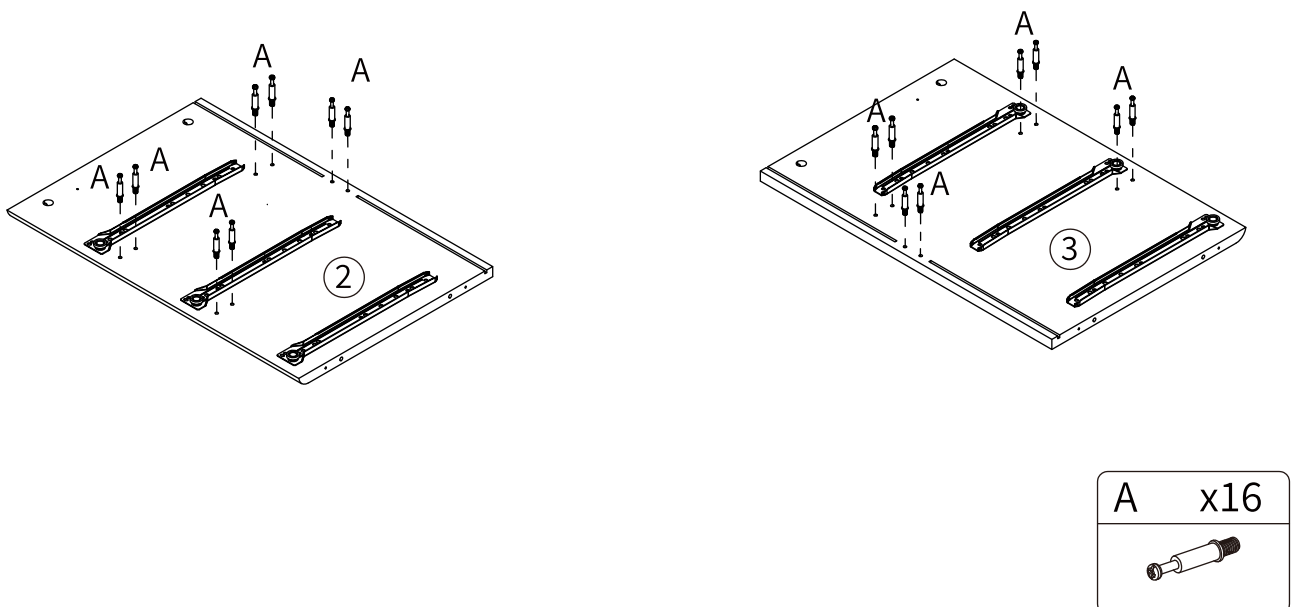

Step 5

Insert screw (A) into corresponding holes on part ②① (X2)&①, fasten the L-shaped iron piece (I) with screw (J) on part ①, the installation position is as shown.

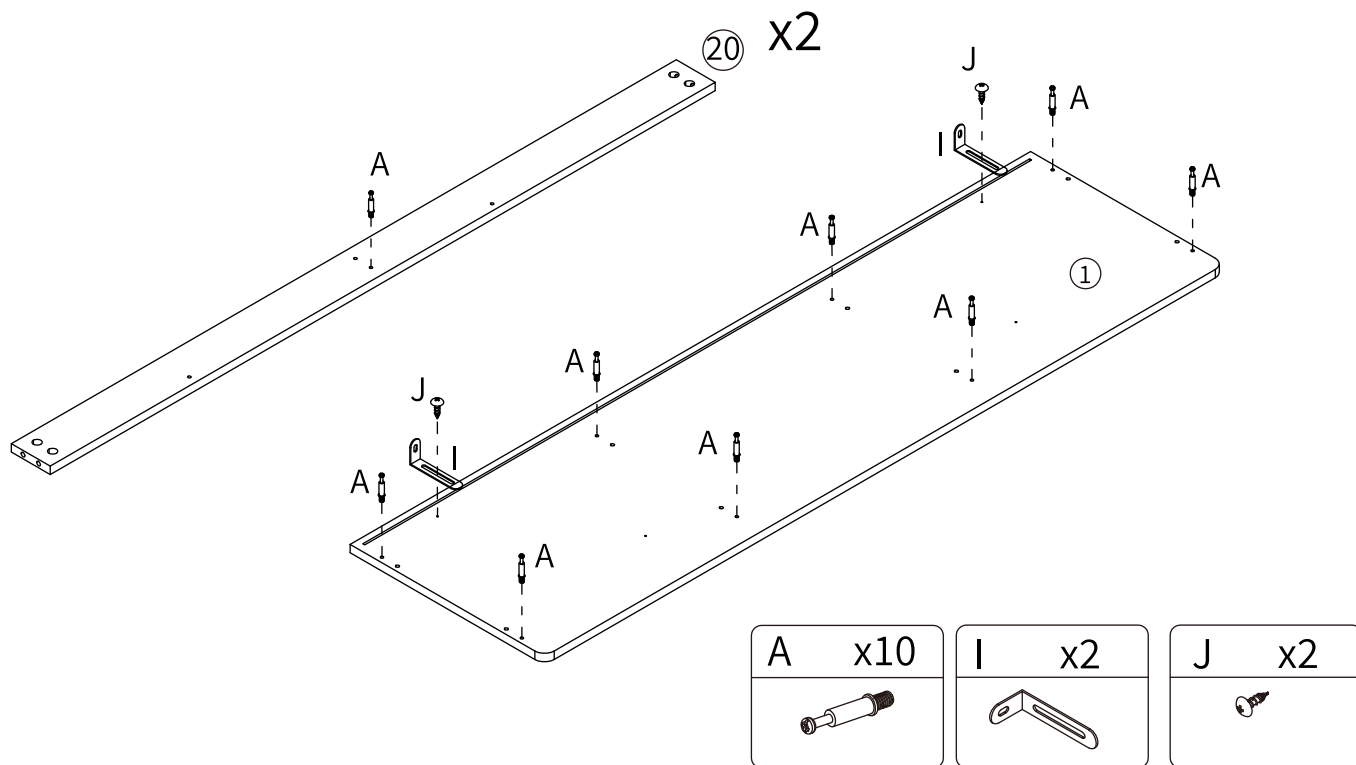

Step 6

Firstly insert the dowel (C) on part ④ (X2), then connect part ④ (X2) to part ②① (X2) with screw (D), the installation position is as shown.

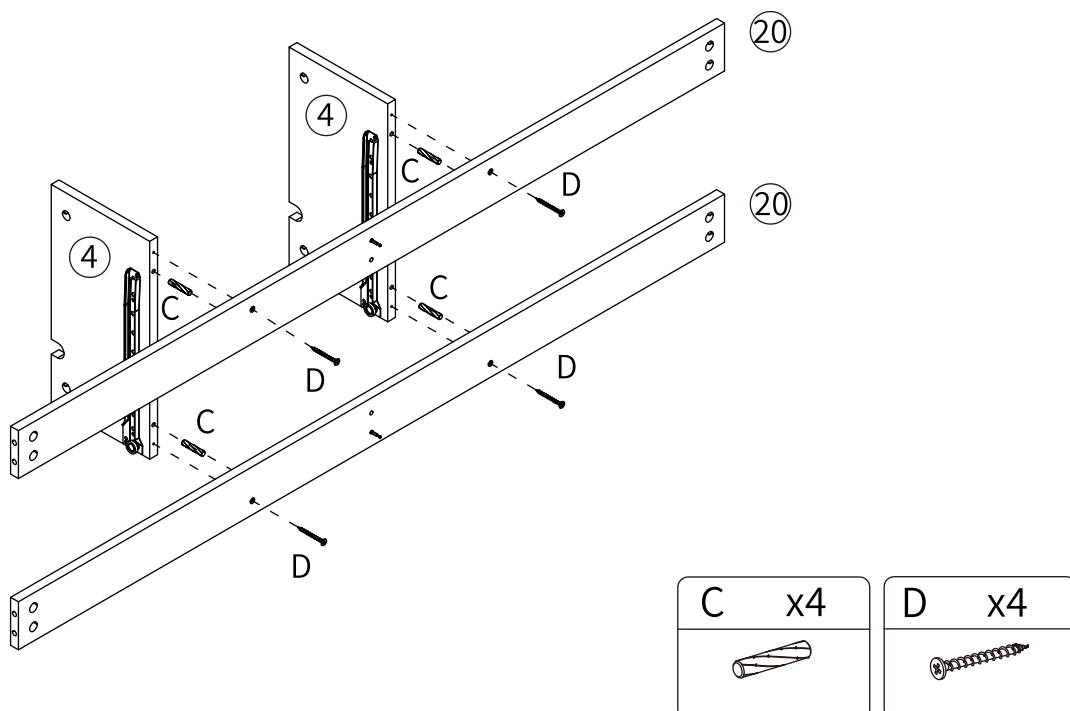

Step 7

Firstly insert the dowel (C) on part ②①, then connect part ②① to part ②① (X2) with cam lock (B), insert cam lock (B) into the corresponding holes on part ②① and use a screwdriver to turn it clockwise to tighten, the installation position is as shown.

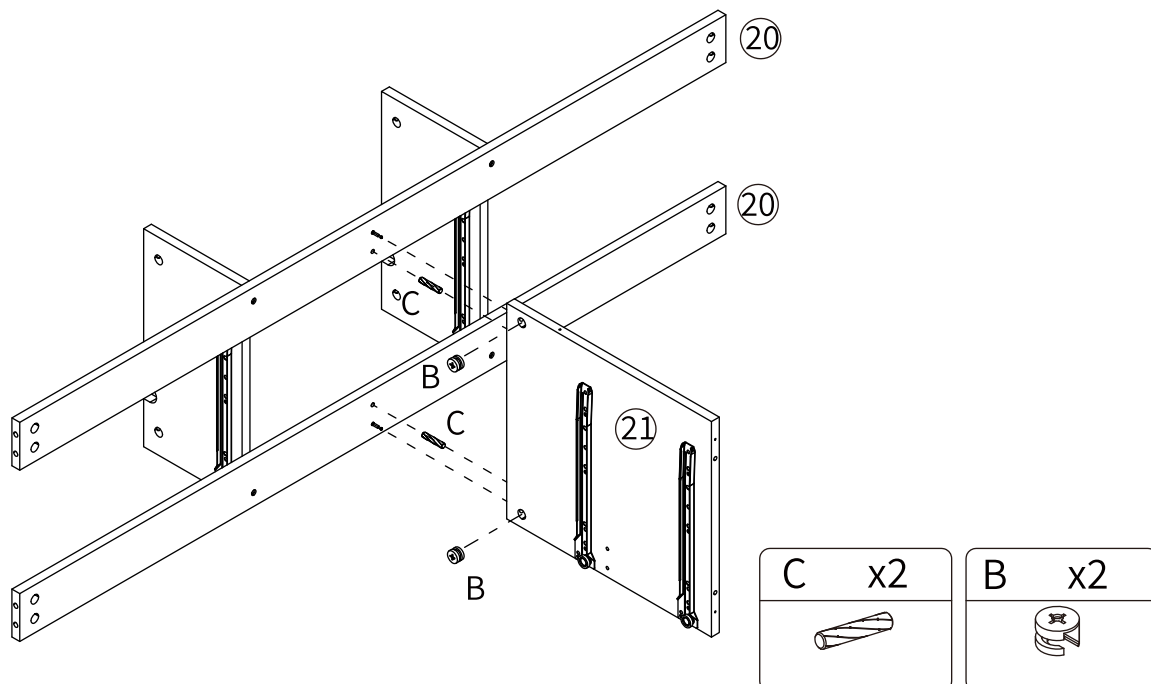

Step 8

Connect part ⑦ (X2) to part ②① with cam lock (B), insert cam lock (B) into the corresponding holes on part ⑦ (X2) and use a screwdriver to turn it clockwise to tighten, the installation position is as shown.

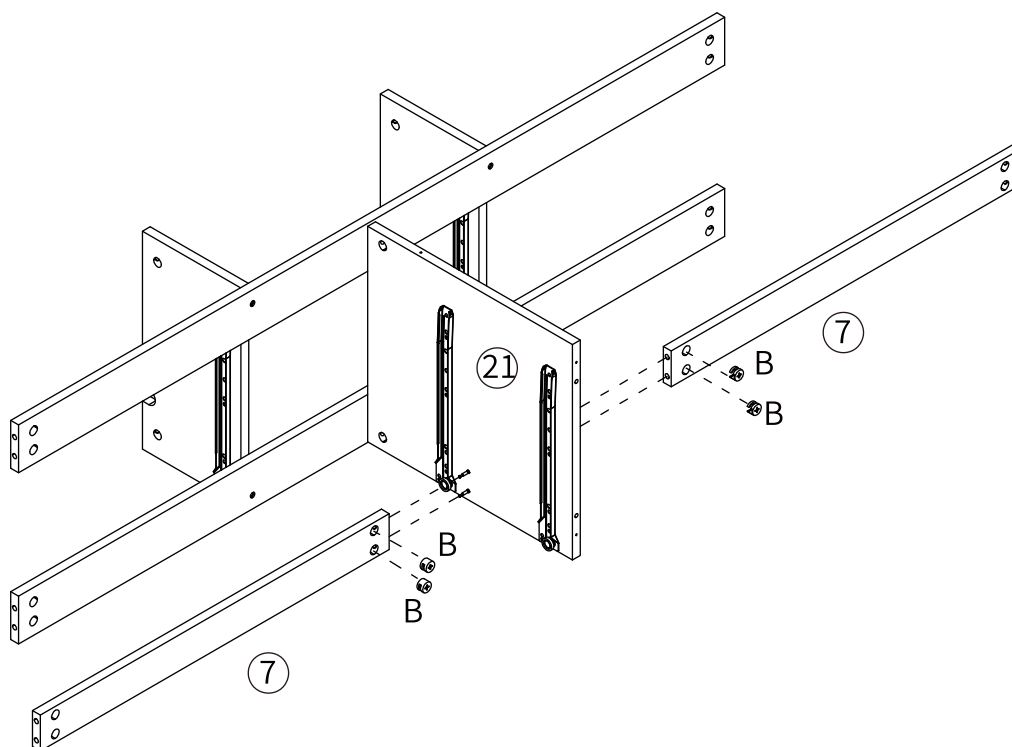

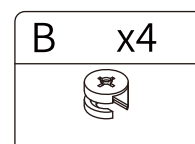

The installation direction should be aligned with the instructions to prevent plate breakage caused by product tipping during installation.

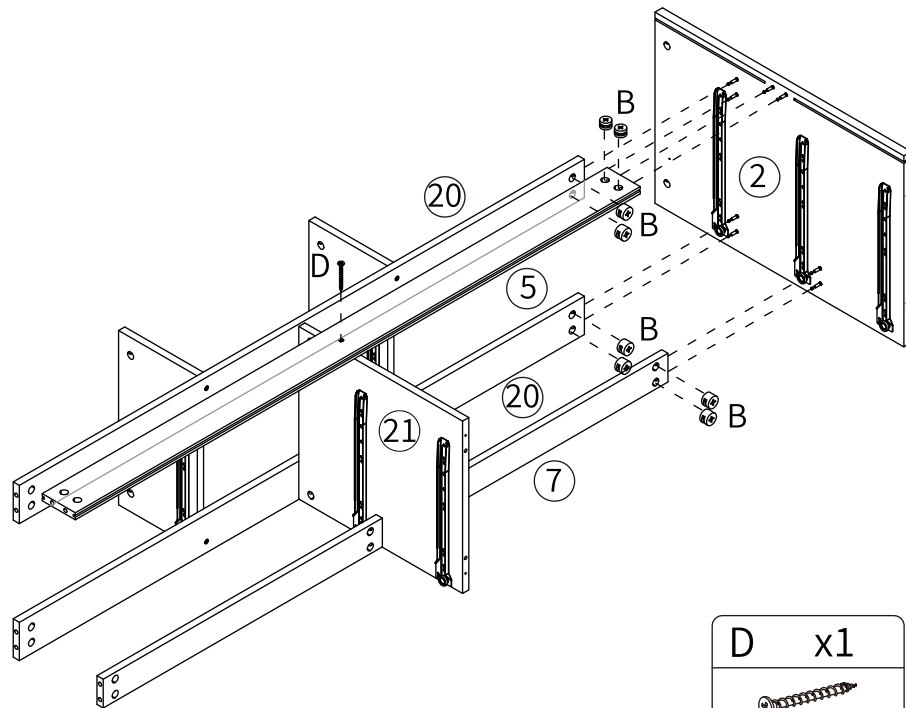

Step 9

Connect part (5) to part (21) with screw (D), connect part (20) (X2) & (5) & (7) to part (2) with cam lock (B), insert cam lock (B) into the corresponding holes on part (20) (X2) & (5) & (7) and use a screwdriver to turn it clockwise to tighten, the installation position is as shown.



D x1	B x8
	

Step 10

Connect part (20) (X2) & (5) & (7) to part (3) with cam lock (B), insert cam lock (B) into the corresponding holes on part (20) (X2) & (5) & (7) and use a screwdriver to turn it clockwise to tighten, the installation position is as shown.

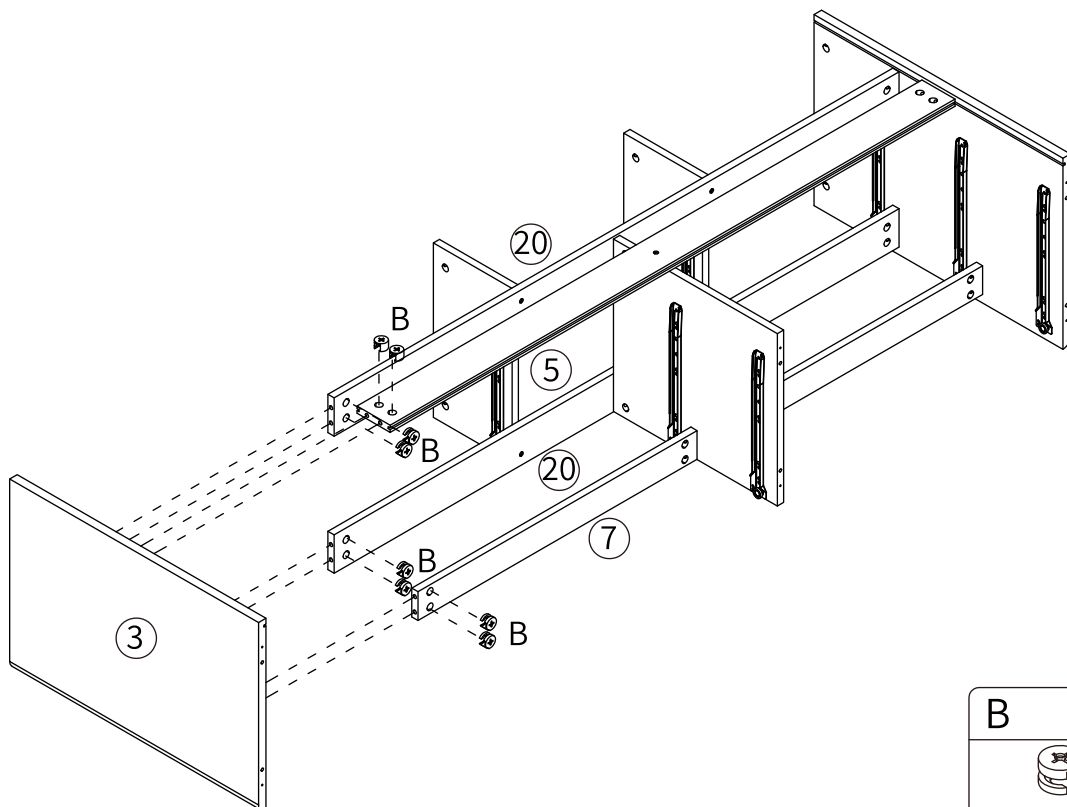

B x8

Step 11

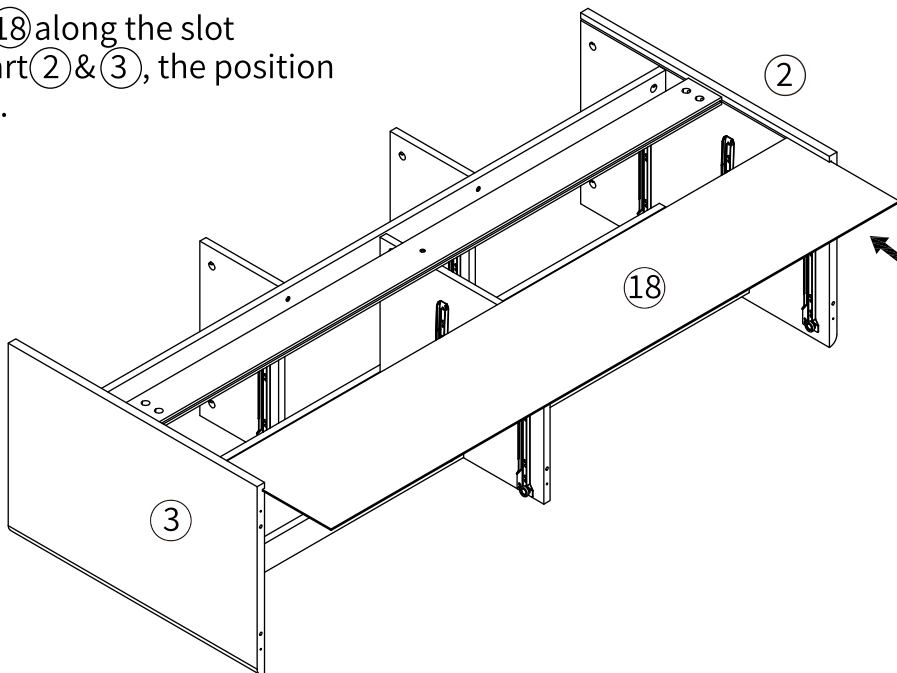

Insert part ⑱ along the slot between part ② & ③, the position is as shown.

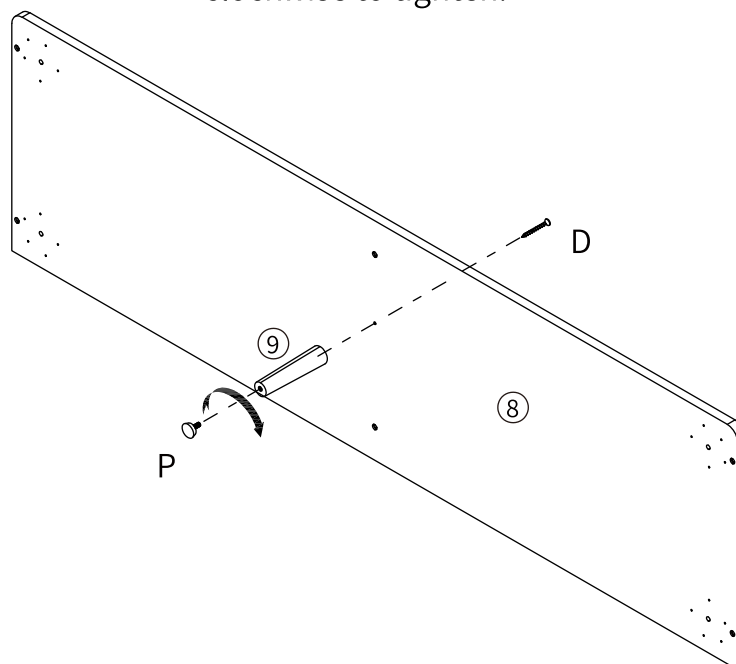

Step 12

Connect part ⑨ to part ⑧ with screw (D), connect tack glide (P) to part ⑨ in clockwise to tighten.



P	x1	D	x1
			

Step 13

Firstly insert the dowel (C) on part (2)&(3)&(21), then connect part (2)&(3)&(21) to bottom panel (8) with screw (D), the installation position is as shown.

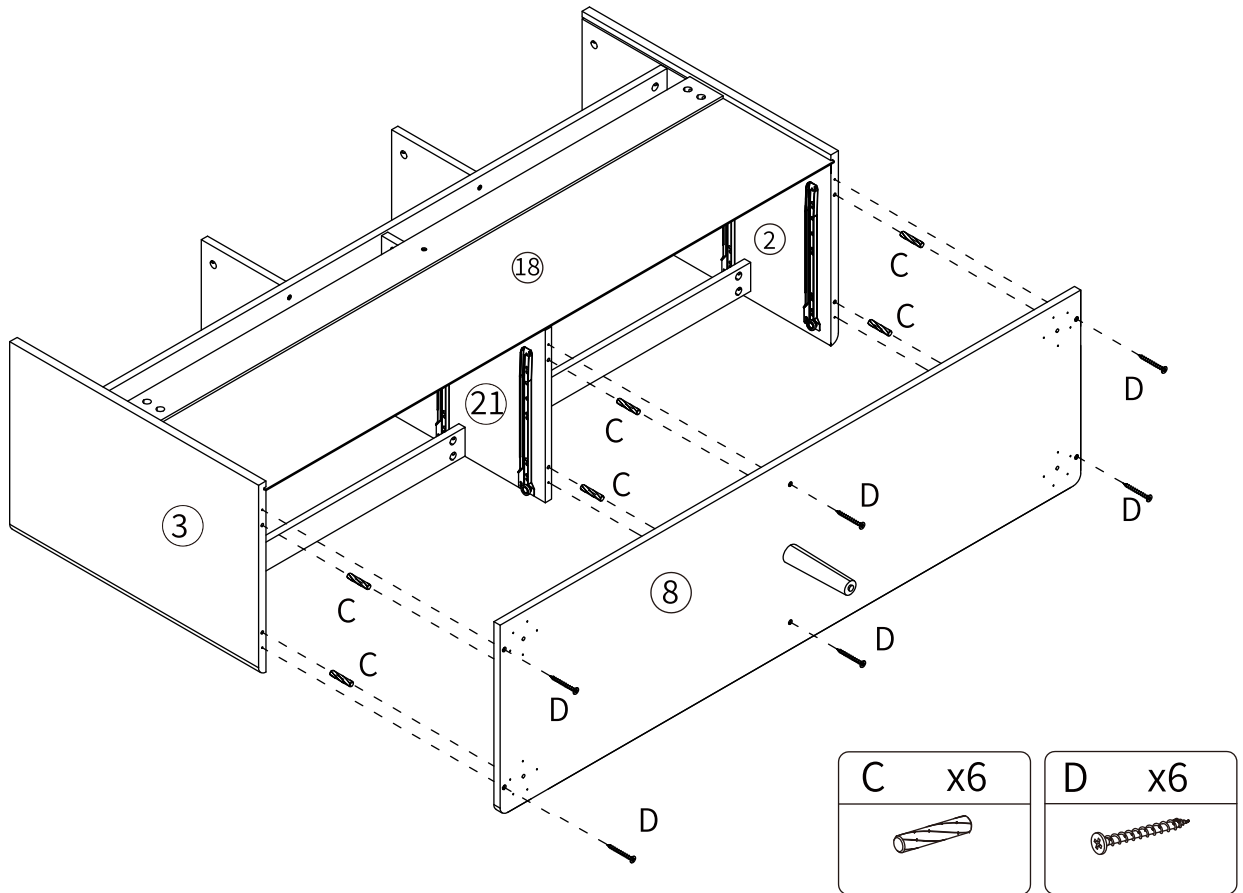

Step 14

Install metal plate (S) on bottom panel (8) with screw (J).

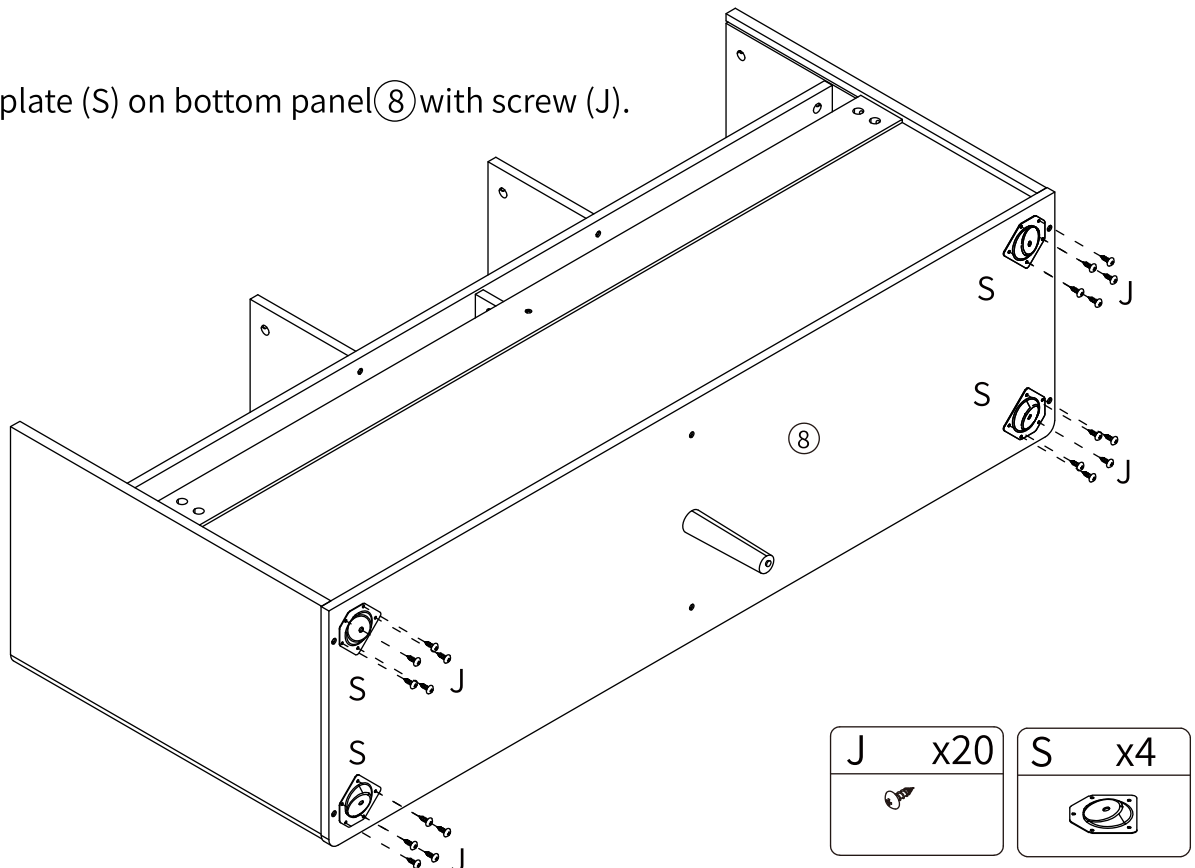

Step 15

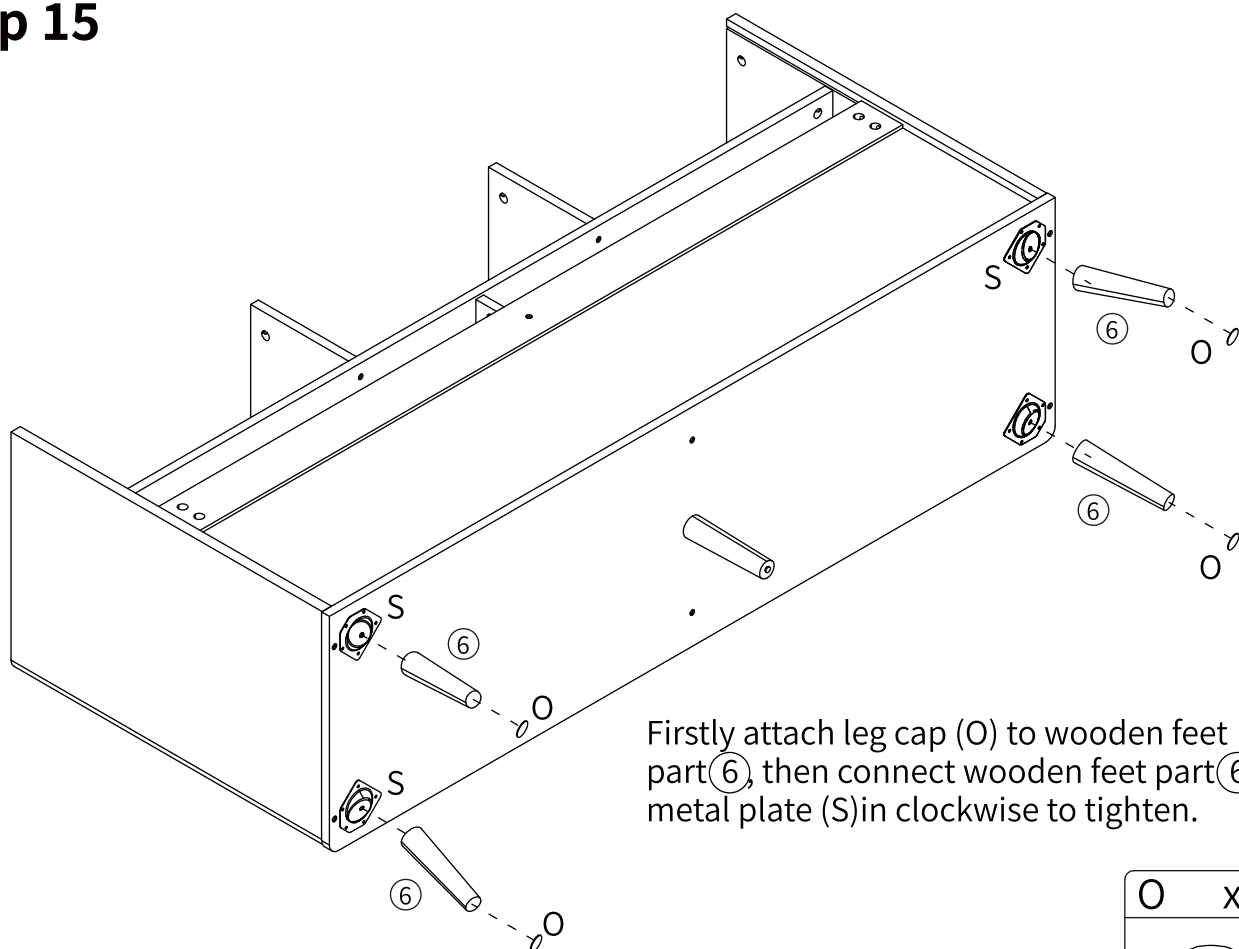

Firstly attach leg cap (O) to wooden feet part (6), then connect wooden feet part (6) to metal plate (S) in clockwise to tighten.

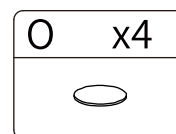

Step 16

Insert part (17) along the slot between part (2) & (3), the position is as shown.

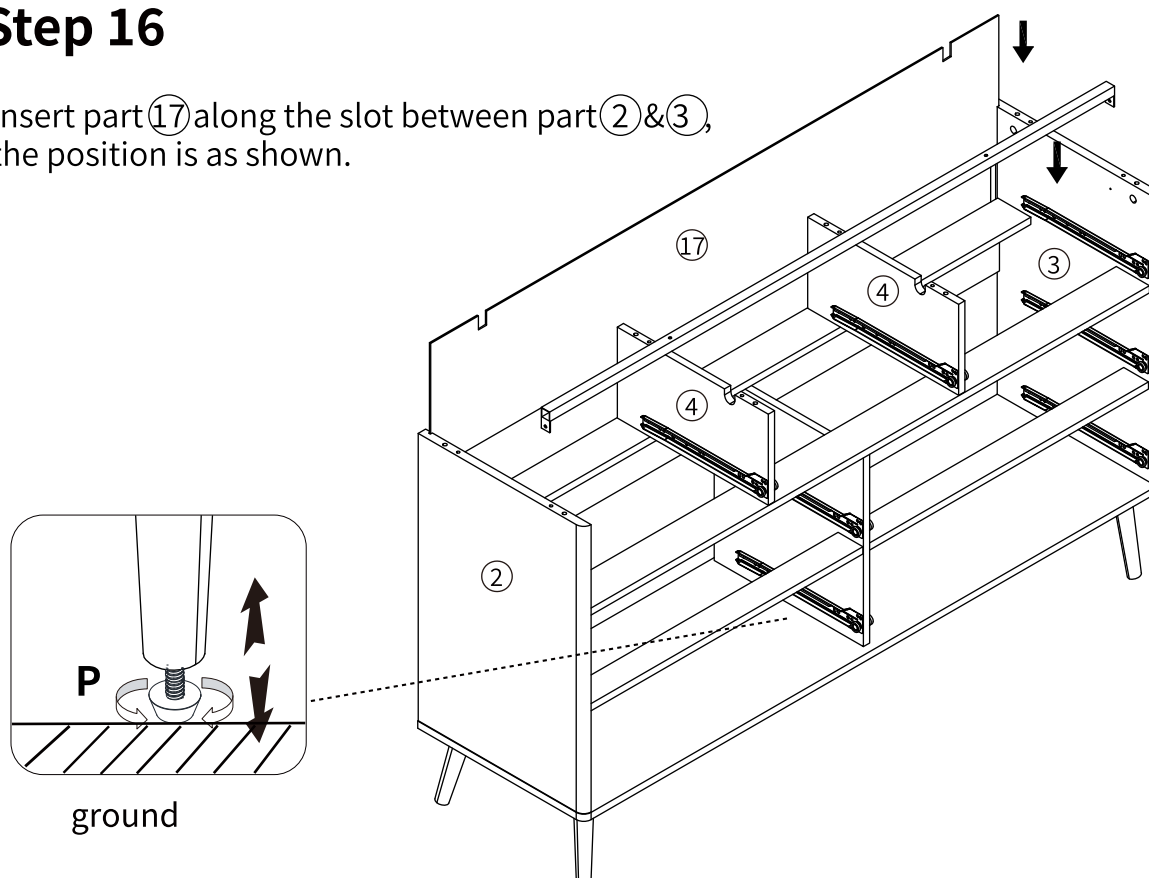

Adjusting the pad (P) on the middle leg, please ensure that it is firmly grounded to prevent any potential dresser collapse caused by hanging.

Step 17

Lock the metal tube (19) to part (2) & (3) with screw (J).

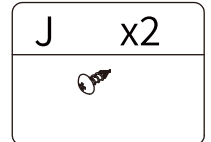
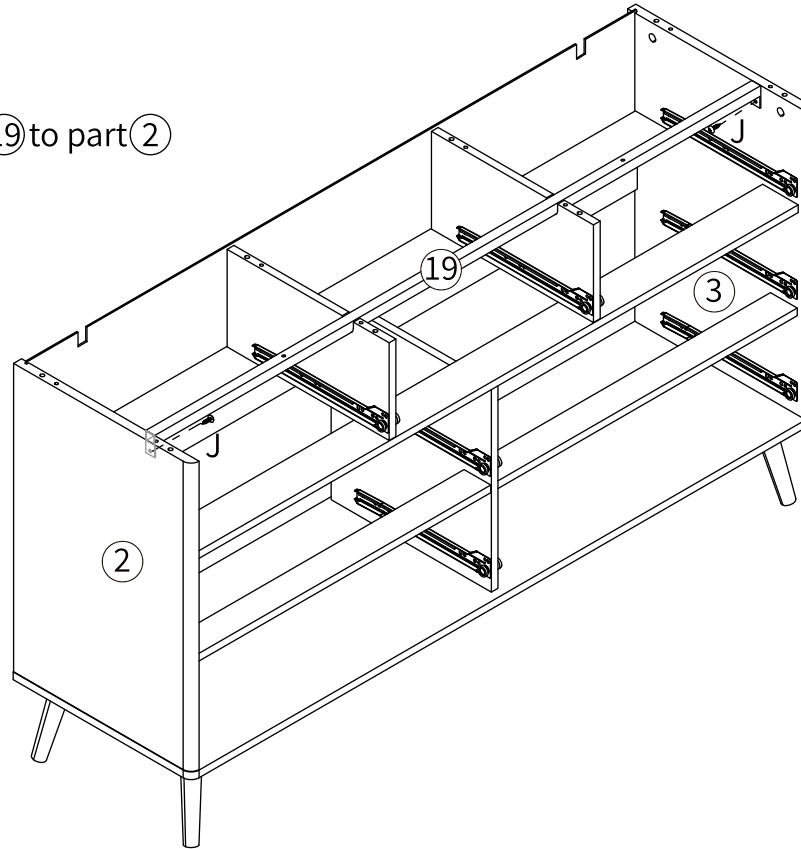

Step 18

Insert the dowel (C) on part (2) & (4) (X2) & (3), connect assembled parts (2) & (4) (X2) & (3) to part (1) with cam lock (B), put the cam lock (B) into the corresponding holes on part (2) & (4) (X2) & (3) and use a screwdriver to turn it clockwise to tighten. Connect part (19) to part (1) with screw (R), the installation position is as shown.

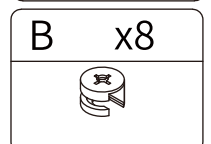
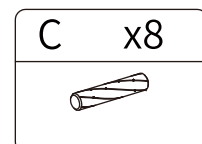
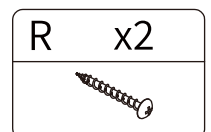
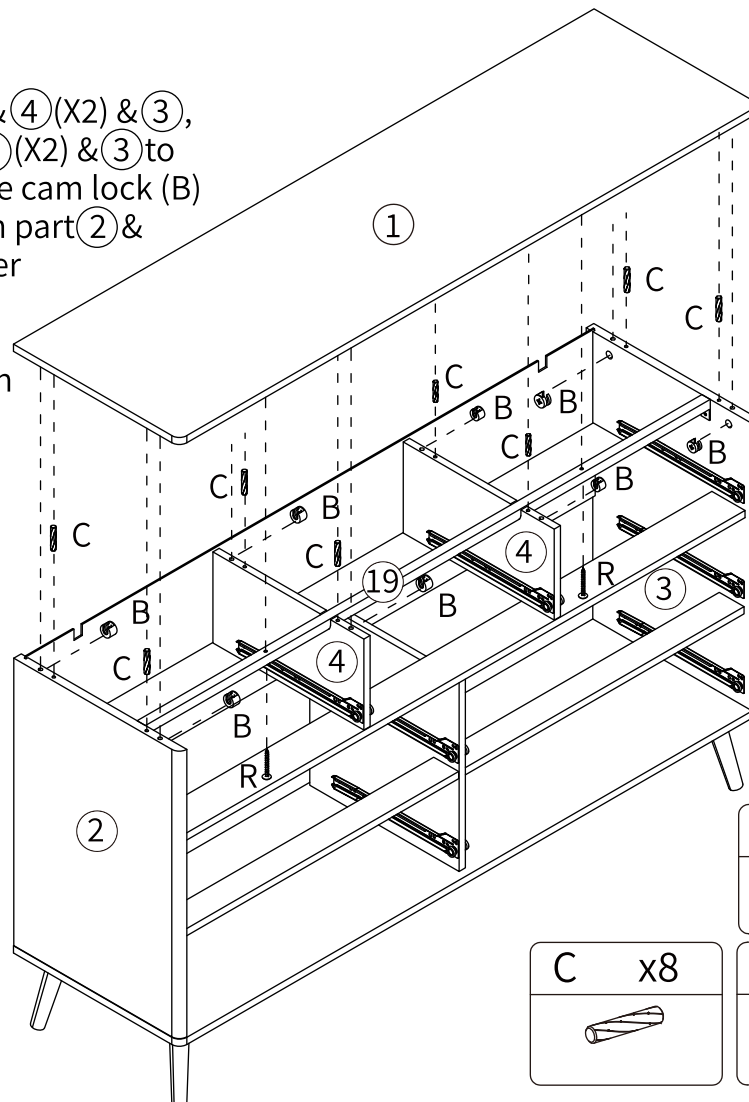

Step 19

Use the screws in component (G), (H) to fasten the back plate buckle. The installation position is as shown.

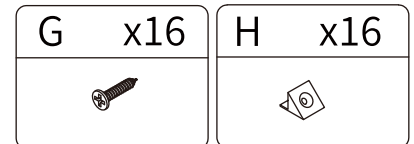
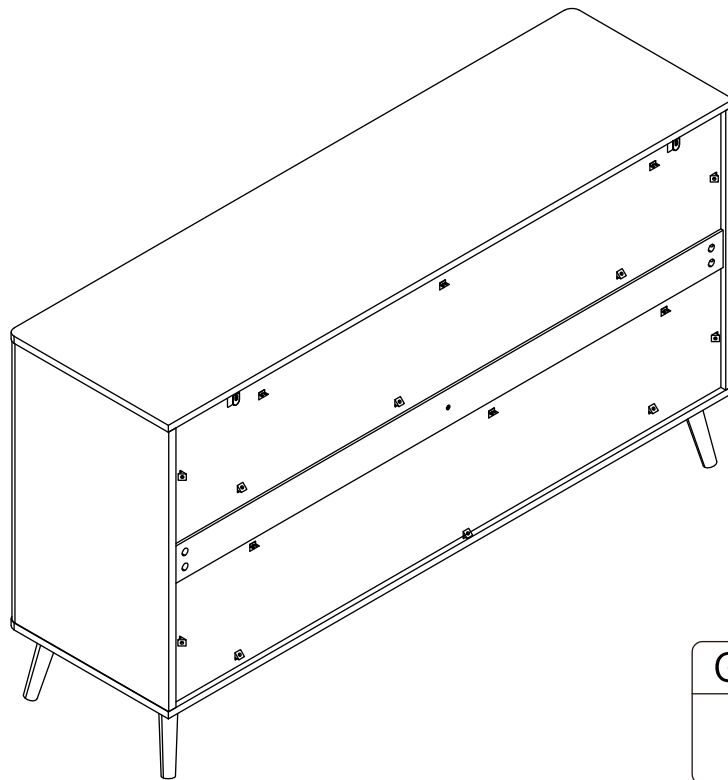

Step 20

First drill holes on the wall where it is placed, then use expansion screw (L) to fix the cabinet with screw (K). The installation location is as shown.

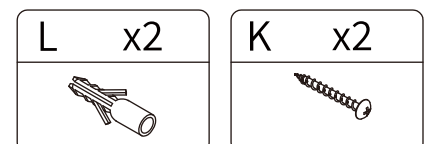
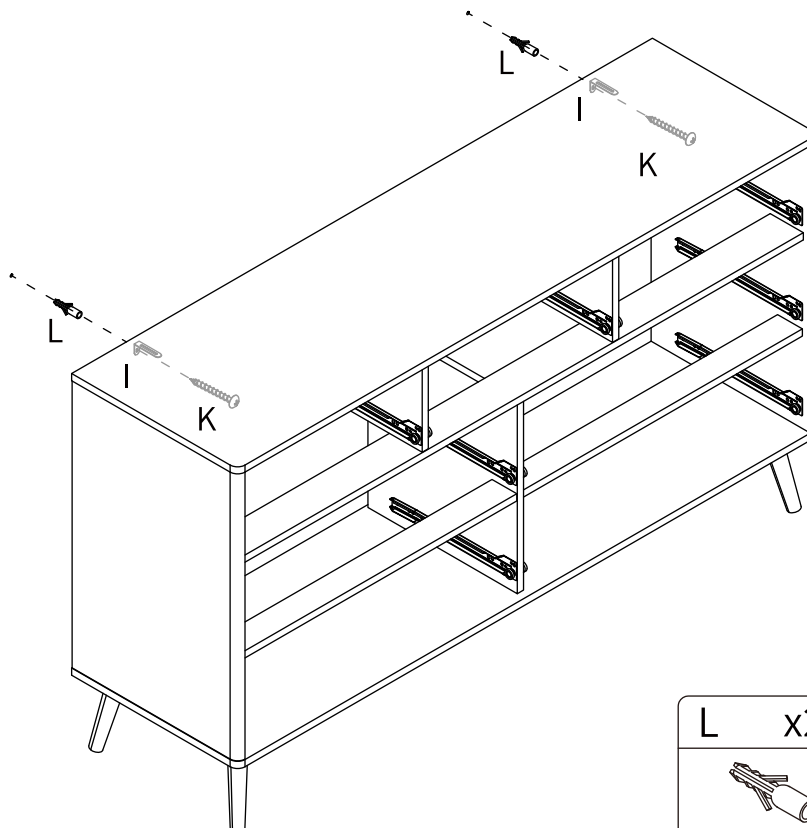

Step 21

Install the screw (A) on the drawer panels ②④ & ②③ & ②② firstly, then use the screw (F) to lock the handle (E) on the drawer panels ②④ & ②③ & ②②.

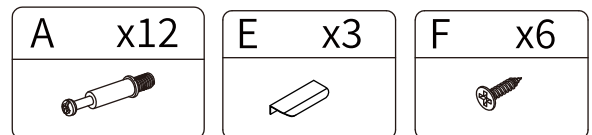
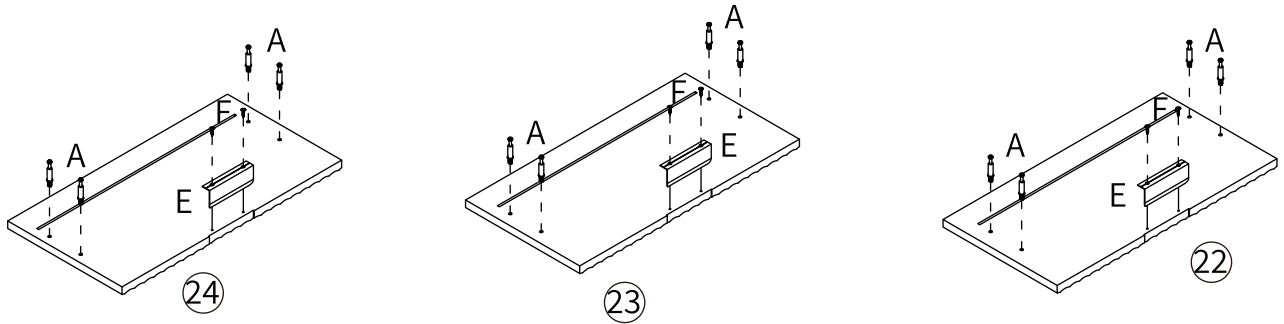

Step 20

Use the screw (M) to connect the side panels ①① & ①② to the back panel ②⑤.

Insert the bottom plate ②⑥ along the slots.

x3

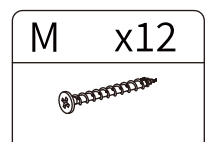
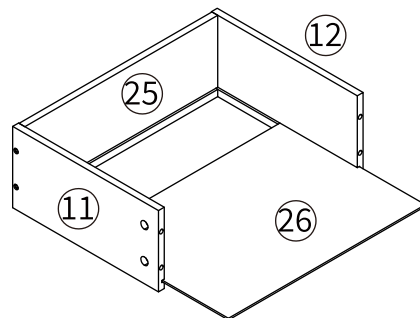
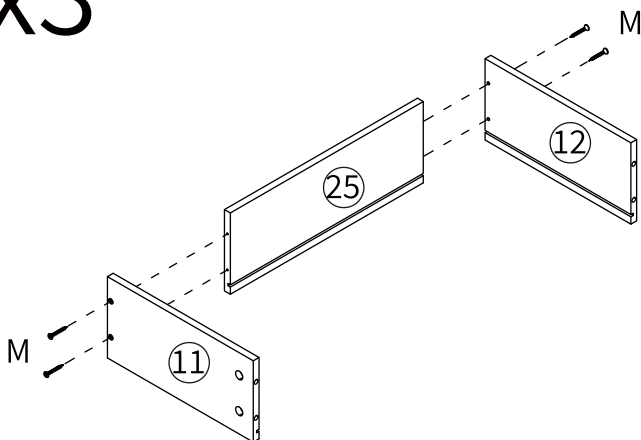

Step 23

Assemble the drawer front plate (22)&(23)&(24) to part (11)&(12), put the cam lock (B) into the corresponding holes on part (11)&(12) and use a screwdriver to turn clockwise to tighten.

x3

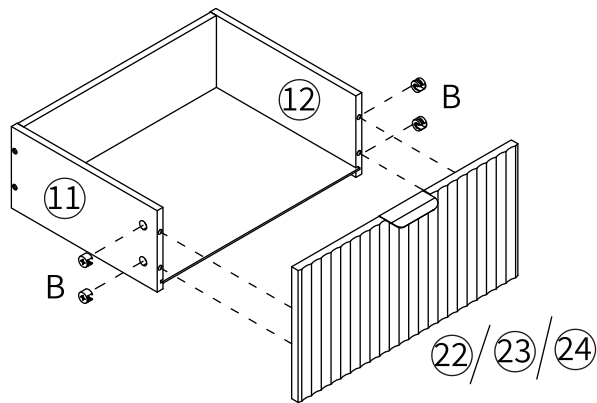

B	x12

Step 24

Use the screw (N) to install the guide rail (DR) on the side panel (12) and install the guide rail (DL) on the side panel (11) with screw (N), the installation position is as shown.

x3

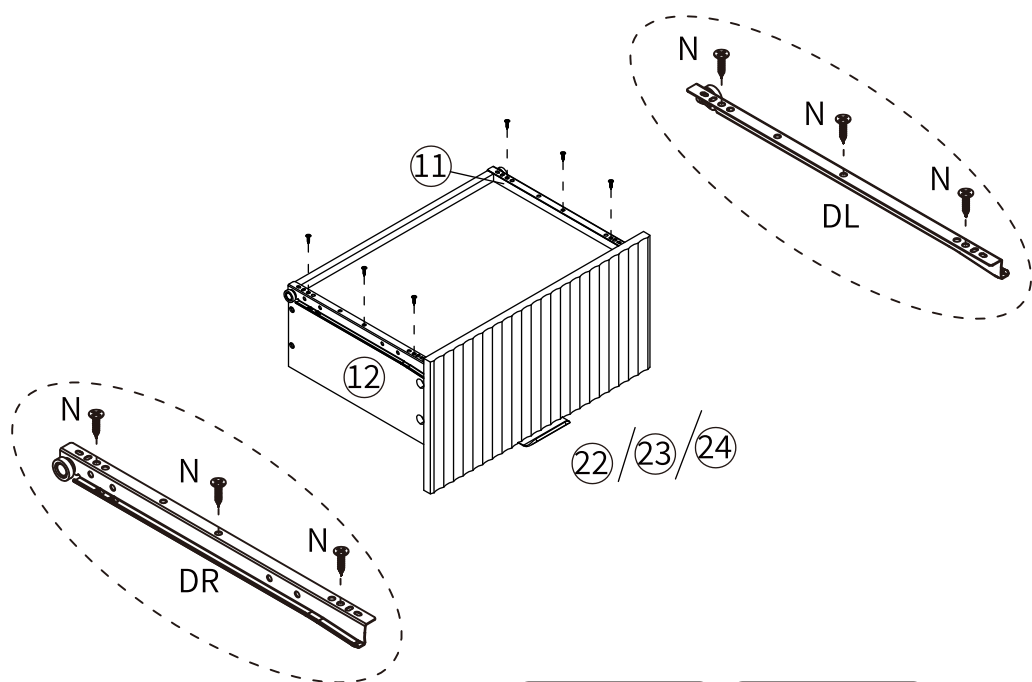

DL	x3

DR	x3

N	x18

Step 25

Install the screw (A) on the drawer panels (16) & (10) firstly, then use the screw (F) to lock the handle (E) on the drawer panels (16) & (10).

x2

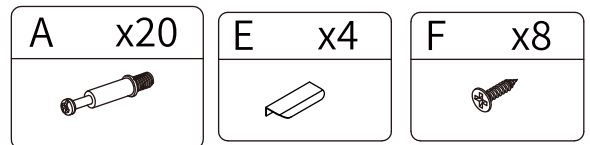
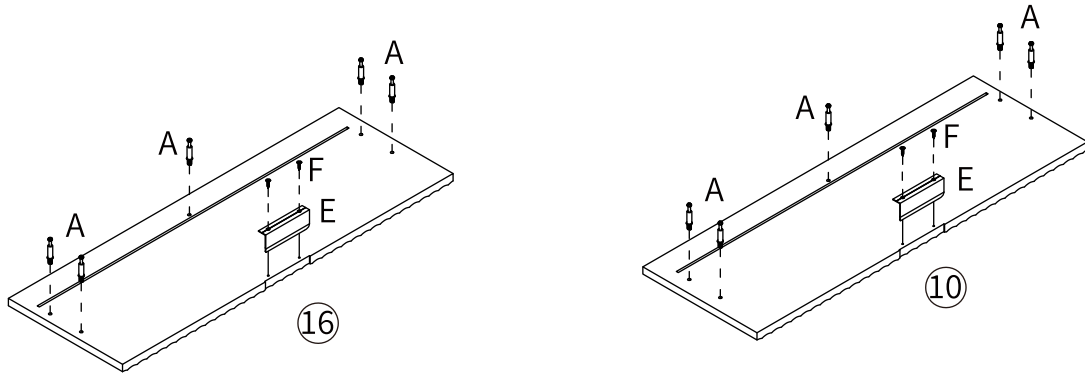

Step 26

Connect part (11) & (12) & (15) and part (13) with screw (M), the installation position is as shown below.

x4

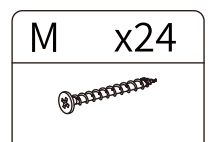
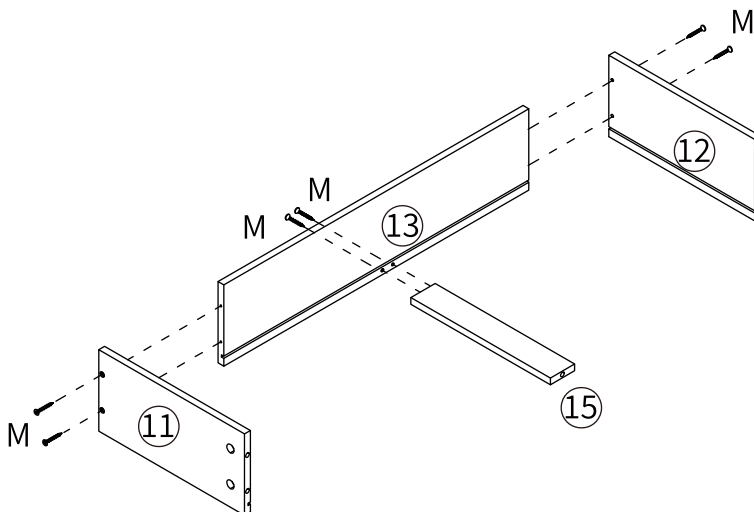

Step 27

Insert the bottom plate (14) along the slots.

x4

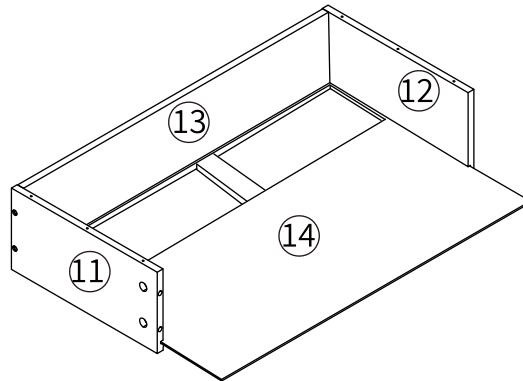

Step 28

Assemble the drawer front plate (10 & 16) to part (11 & 12), put the cam lock (B) into the corresponding holes on part (11 & 12 & 15) and use a screwdriver to turn clockwise to tighten.

x4

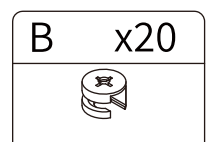
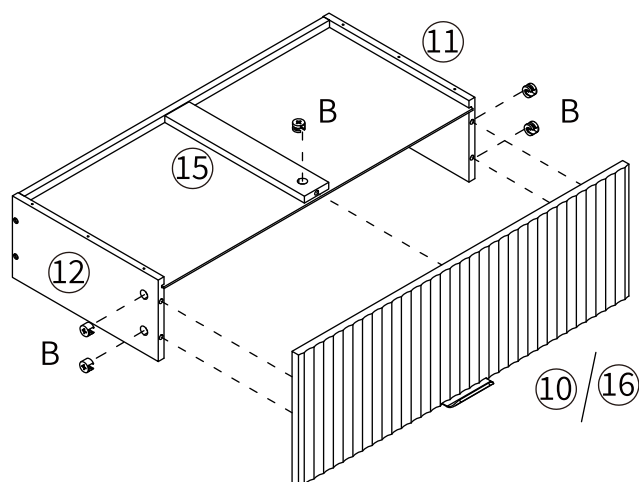

Step 29

Use the screw (N) to install the guide rail (DR) on the side panel (12) and install the guide rail (DL) on the side panel (11) with screw (N), the installation position is as shown.

x4

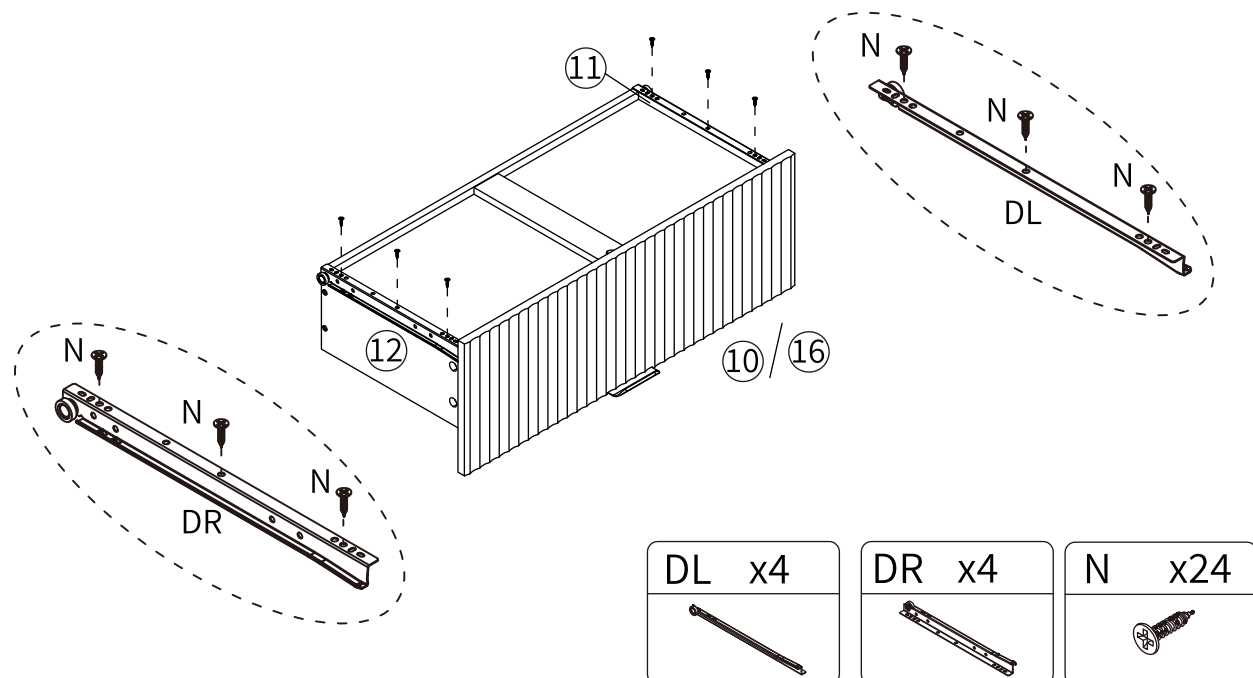

Step 30

Install the drawers into corresponding drawer spaces as shown.

