

---

Before you start, here are some helpful advice:

1. We suggest you spend a short time reading through this leaflet and then follow the simple step-by step instructions
  2. Owing to the size and weight of the sofa, we recommend that it is assembled by two adults on a carpeted or padded area, in the room that it is intended for. Approximate time: 30 minutes.
  3. Please do not use any tools other than those provided or recommended in these instructions.
  4. Please do not throw away any of the packaging or instructions until you have checked all the components and hardware and the furniture is fully assembled.
  5. Assemble all components loosely until advised to tighten. Depending on use, it may be necessary to tighten the component from time to time,so please save the tools that have been provided.
  6. Please keep all pieces out of reach of children.
- 

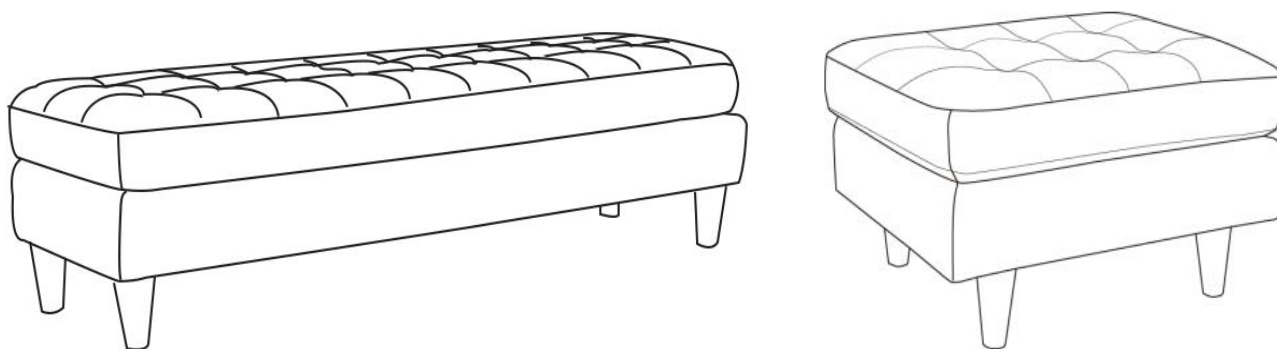

---

**Components:**

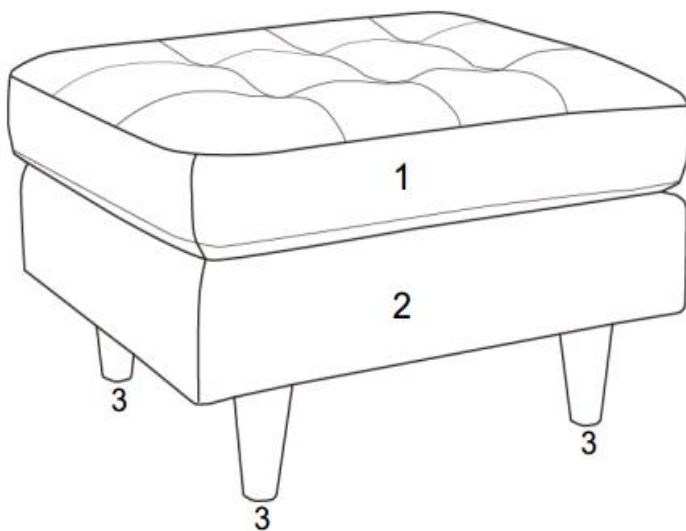

1. Ottoman Cushion x1

2. Ottoman Base x1

3. Leg x4

---

**STEP 1:**

Please put the **Ottoman Base (2)** upside down on a carpeted or padded area.

Open the Zipper on the bottom of **Ottoman Base (2)** as shown, take out the packages of 4 pieces of **Legs (3)**, then close the Zipper on the bottom of **Ottoman Base(2)**. Take off the Black Protection Cover on the **Legs (3)**.

Please insert 1 piece of **Leg (3)** into the hole on the round metal plate in the corner. Use hands to tighten the **Leg (3)** clockwise until secure. Repeat the same steps for other 3 pieces of **Legs (3)**.

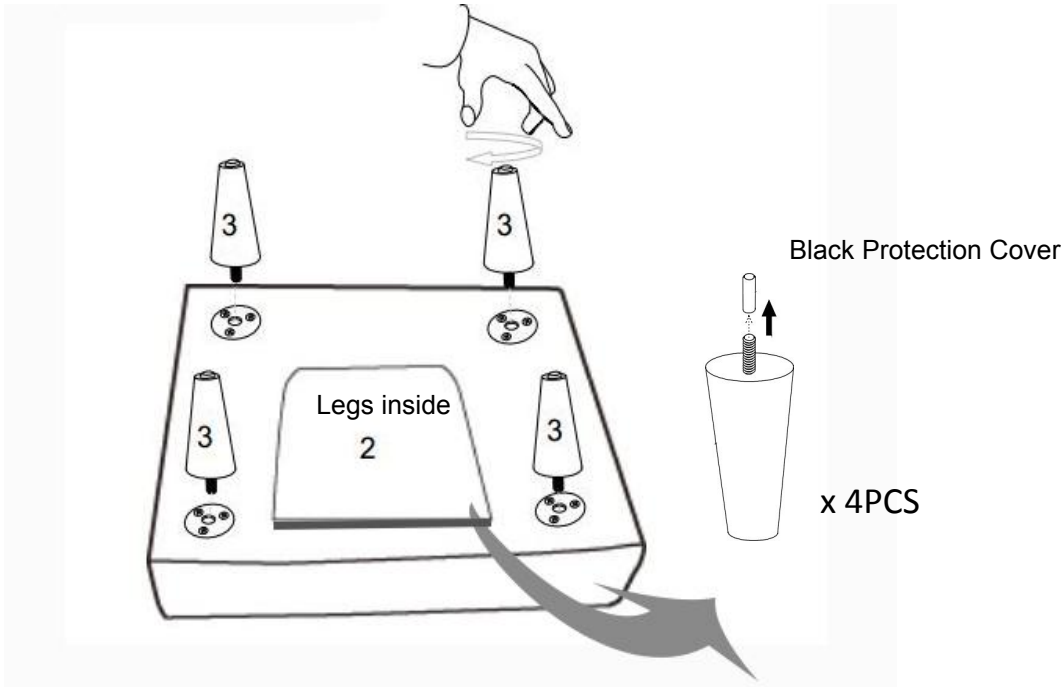

---

**STEP 2:**

Carefully turn over the **Ottoman Base (2)**, please take off the protection film on the Velcro of **Ottoman Base (2)**.

Attach the **Ottoman Cushion (1)** to the **Ottoman Base (2)** by the Velcro at the top of **Ottoman Base (2)** as shown.

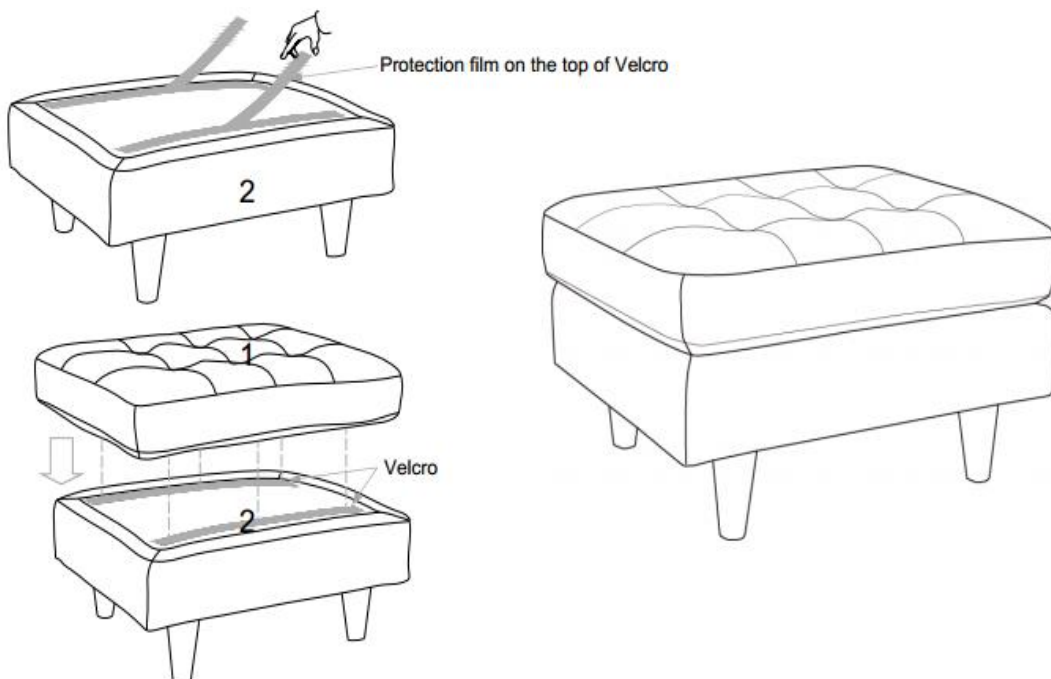

Assembly is complete. The ottoman is ready to enjoy now!