

# ASSEMBLY INSTRUCTIONS

---

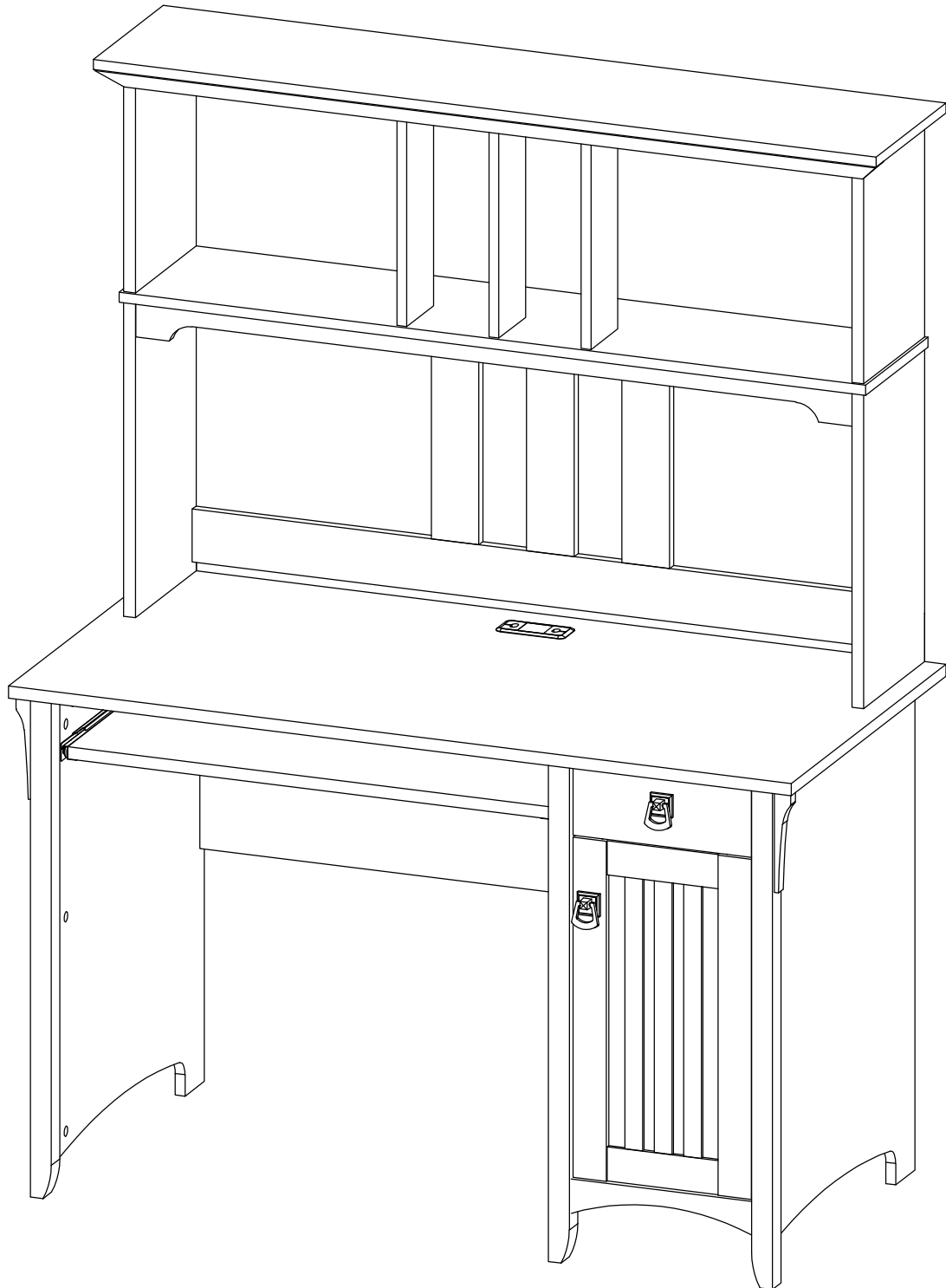

**Thank you for purchasing** this

product. We trust that you will be completely satisfied with your product for many years to come.

Our products are backed by a 1-year warranty and crafted with today's styles in mind for the way you work.

**Merci d'avoir acheté** ce produit

Nous sommes sûr que vous serez complètement satisfait de votre meuble pendant de nombreuses années. Les produits sont garantis pendant 1 ans et sont conçus dans les styles actuels tout en gardant à l'esprit votre façon de travailler.

**Gracias por comprar** este producto de

. Confiamos que usted estará completamente satisfecho con su mueble por muchos años. Los productos de tienen 1 años de garantía y son diseñados con los estilos de hoy en mente para la manera que usted vive.

# IT'S AS EASY AS 1,2,3

**Assembly tips:**

1. Read the instructions and become familiar with the parts.
2. Ensure this carton contains all parts, fasteners and hardware.
3. To protect floors, assemble the furniture on the carton.
4. An assistant may be helpful.
5. Use of power tools is not recommended.

**Conseils d'assemblage:**

1. Lisez les instructions et familiarisez-vous avec les pièces.
2. Assurez-vous que le carton contient toutes les pièces, toutes les pièces de fixation et toute la quincaillerie.
3. Pour protéger vos sols, assemblez le meuble sur le carton.
4. Il peut être utile de vous faire aider.
5. L'utilisation d'outils électriques n'est pas recommandée.

**Consejos de Ensamblaje:**

1. Lea las instrucciones y familiarícese con las partes.
2. Asegúrese de que esta caja contenga todas las piezas, los sujetadores y el equipo.
3. Para proteger el piso, ensamble el mueble en el carton.
4. Un asistente puede serle útil.
5. El uso de herramientas eléctricas no se recomienda.

## IMPORTANT SAFETY INFORMATION



### WARNING

Units must be assembled with the instructions, parts and hardware provided. Improper assembly or use could cause structural failure, instability, tip over, and/or serious injury.

Las unidades deben ser ensambladas de acuerdo a las instrucciones y usando el herraje incluido. El ensamblado incorrecto puede causar un fallo estructural, inestabilidad, o que la unidad se derrumbe, causando posibles heridas personales.

Les unités doivent être assemblées avec les instructions et les matériels donnés. Si vous ne le construisez pas correctement ceci pourrait causer des dommages structuraux, instabilité, se renverser et blesser quelqu'un.

### NOTICE (STEP19)

This compartment is intended to hold computer equipment. the door must be kept open when equipment is operated. failure to do so could restrict airflow and may result in equipment overheating.

El compartimiento está diseñado para acomodar un computador. la puerta debe mantenerse abierta mientras el equipo es operado. el no mantener la puerta abierta durante la operación puede restringir el flujo de aire y resultar en el computador calentarse demasiado.

Ce compartiment est prévu pour tenir le matériel informatique. la porte doit être maintenue ouverte tandis que le matériel est utilisé. le manque de faire ainsi a pu limiter la circulation d'air et peut avoir comme conséquence la surchauffe du matériel.



### WARNING

Do not move unit when loaded. Doing so could cause instability, product collapse, tip over, and/or serious injury.

No mueva la unidad cuando esté cargada. Hacerlo puede causar inestabilidad, que el producto se derrumbe, que se la caiga encima y/o heridas (golpes) serias.

Ne pas déplacer l'unité lorsqu'elle est chargée. Faire ainsi peut causer l'instabilité, l'effondrement ou le renversement du meuble et/ou des endommagements sérieux.



### WARNING

Do not load unit without properly attaching back panel. Doing so could cause instability, product collapse, and/or serious injury.

No cargue esta unidad sin el panel de atrás. Hacerlo puede causar inestabilidad, que el producto se derrumbe, y/o heridas (golpes) serias.

Ne pas charger le produit sans attacher correctement le panneau arrière. Faire ainsi peut causer l'instabilité ou l'effondrement du produit et peut vous causer des endommagements sérieux.

## IMPORTANT SAFETY INFORMATION



### WARNING

**Caution, restricting airflow may result in equipment overheating.**

Vent hole punch outs must be removed to provide adequate venting and cooling of electronic equipment. If power exceeds a maximum recommended wattage of 400 W per shelf location, the door must be left open when in use. Failure to do so could restrict airflow and may result in equipment overheating.

**Precaución, la restricción del flujo de aire puede provocar el sobrecalentamiento del equipo.**

Las perforaciones de los orificios de ventilación deben retirarse para proporcionar ventilación y enfriamiento adecuados de los equipos electrónicos. Si la potencia excede una potencia máxima recomendada de 400 W por ubicación de estante, la puerta debe dejarse abierta cuando esté en uso. De lo contrario, se podría restringir el flujo de aire y el equipo podría sobrecalentarse.

**Attention, la limitation du débit d'air peut entraîner une surchauffe de l'équipement.**

Les perforations des trous d'évent doivent être retirées pour permettre une ventilation et un refroidissement adéquats de l'équipement électronique. Si la puissance dépasse une puissance maximale recommandée de 400 W par emplacement, la porte doit rester ouverte lors de son utilisation. Si vous ne le faites pas, cela pourrait limiter le flux d'air et entraîner une surchauffe de l'équipement.



### WARNING

This hutch must be assembled, installed, and supported as defined in the assembly manual. Hutch must be placed against a permanent wall structure at least as tall as the hutch or placed back-to-back with another hutch of same size. Failure to assemble, install, or support this hutch as described in the assembly manual could cause loss of stability or tip over and result in serious injury or death.

Este armario debe ser ensamblado, instalado y apoyado como esta descrito por el manual de ensamblaje. Este armario debe ser colocado en contra de una estructura de pared permanente o por lo menos la misma altura del armario o posicionado espalda con espalda con otro armario de la misma altura. Fracaso en ensamblaje, instalacion o apoyo de este armario como esta dispuesto en el manual de ensamblaje puede causar perdida de estabilidad o volcar y resultar en lesiones serias o muerte.

Cette huche être monté, installé et soutenue tel que défini dans le manuel de montage. La huche doit être placé contre une structure de mur permanent au moins aussi grande que la huche ou placé dos à dos avec unautre huche de même taille. Défaut d' assembler, installer, ou soutenir cette huche tel que décrit dans le manuel de montage pourrait entraîner une perte de stabilité ou la faire basculer ce qui entraine des blessures graves ou la mort.



### WARNING

Failure to install every indicated nail and/or screw could lead to excessive shelf sagging or product collapse resulting in serious injury or death.

Si no se instalan todos los clavos y / o tornillos indicados, se podría producir un hundimiento excesivo del estante o el colapso del producto, lo que podría provocar lesiones graves o la muerte.

Le fait de ne pas installer chaque clou et / ou vis indiqué pourrait entraîner un affaissement excessif de l'étagère ou un effondrement du produit, entraînant des blessures graves, voire mortelles.

**MAXIMUM RECOMMENDED WEIGHT LOADS**

**MAXIMUM WEIGHT: 0 LBS (0 KG)  
PESO MÁXIMO: 0 LIBRAS (0 KILOGRAMO)  
POIDS MAXIMUM: 0 LIVRES (0 KILOGRAMME)**

**MAXIMUM WEIGHT: 50 LBS (22.7 KG)  
PESO MÁXIMO: 50 LIBRAS (22.7 KILOGRAMO)  
POIDS MAXIMUM: 50 LIVRES (22.7 KILOGRAMME)**

**MAXIMUM WEIGHT: 150 LBS (68.2 KG)  
PESO MÁXIMO: 150 LIBRAS (68.2 KILOGRAMO)  
POIDS MAXIMUM: 150 LIVRES (68.2 KILOGRAMME)**

**MAXIMUM WEIGHT: 20 LBS (9 KG)  
PESO MÁXIMO: 20 LIBRAS  
(9 KILOGRAMO)  
POIDS MAXIMUM: 20 LIVRES  
(9 KILOGRAMME)**

**MAXIMUM WEIGHT: 6 LBS (2.7 KG)  
PESO MÁXIMO: 6 LIBRAS (2.7 KILOGRAMO)  
POIDS MAXIMUM: 6 LIVRES (2.7 KILOGRAMME)**

**MAXIMUM WEIGHT: 50 LBS (22.7 KG)  
PESO MÁXIMO: 50 LIBRAS (22.7 KILOGRAMO)  
POIDS MAXIMUM: 50 LIVRES (22.7 KILOGRAMME)**

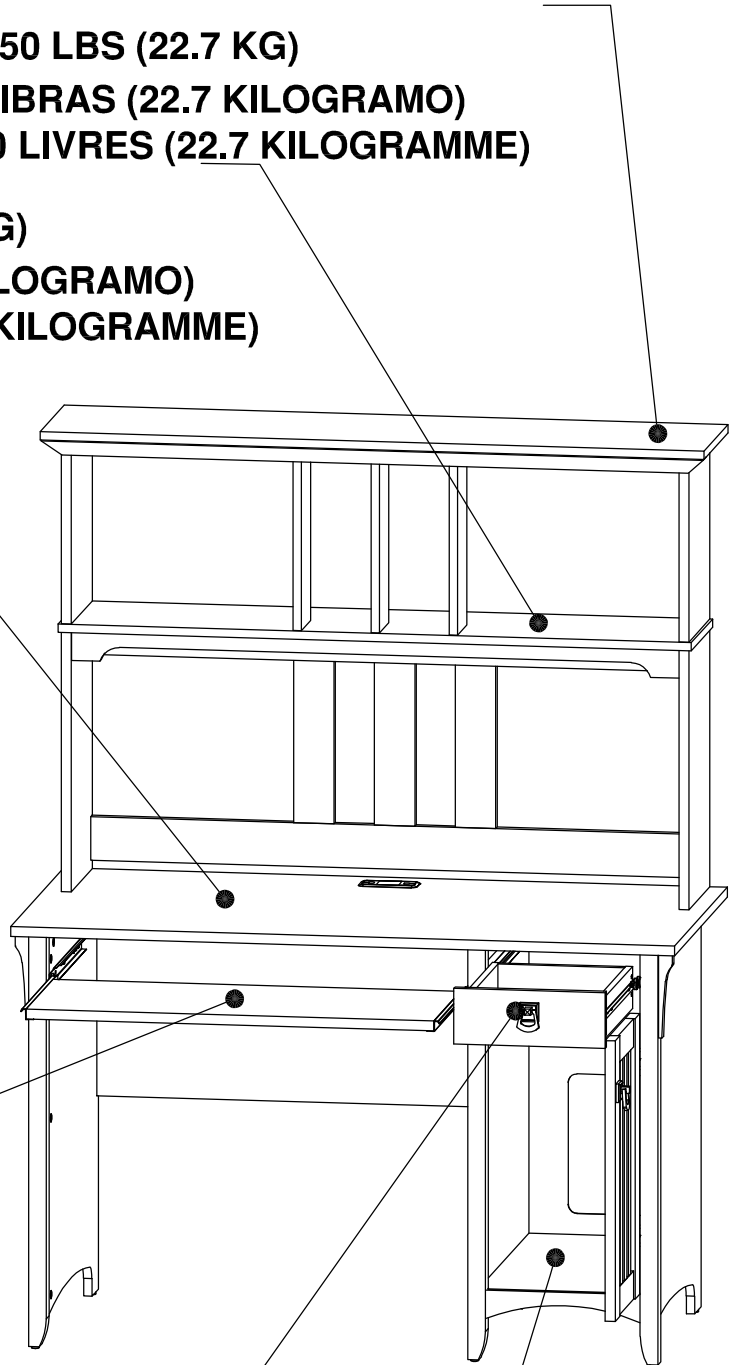



## PARTS LIST

---

A [1]	W159958	Q [1]	W159974
B [1]	W159959	R [1]	W159975
C [1]	W159960	S [1]	W159976
D [1]	W159961	T [1]	W159977
E [1]	S159962	U [1]	W159978
F [1]	W159963	V [1]	W159979
G [1]	S159964	W [3]	W159980
H [1]	W159965	X [1]	W159981
I [1]	W159966	Y [1]	W159982
J [1]	W159967	Z [1]	W159983
K [1]	W159968	AA [1]	W159984
L [1]	W159969	BB [1]	S159985
M [1]	W159970	CC [1]	W159986
N [1]	W159971	DD [1]	W159987
O [1]	W159972	EE [1]	W159988
P [1]	W159973	FF [1]	W159989

## PARTS LIST

---

A [1]	W174645	Q [1]	W174661
B [1]	W174646	R [1]	W174662
C [1]	W174647	S [1]	W174663
D [1]	W174648	T [1]	W174664
E [1]	S174649	U [1]	W174665
F [1]	W174650	V [1]	W174666
G [1]	S174651	W [3]	W174667
H [1]	W174652	X [1]	W174668
I [1]	W174653	Y [1]	W174669
J [1]	W174654	Z [1]	W174670
K [1]	W174655	AA [1]	W174671
L [1]	W174656	BB [1]	S174672
M [1]	W174657	CC [1]	W174673
N [1]	W174658	DD [1]	W174674
O [1]	W174659	EE [1]	W174675
P [1]	W174660	FF [1]	W174676

## PARTS LIST

---

A [1] W188623	Q [1] W188639
B [1] W188624	R [1] W188640
C [1] W188625	S [1] W188641
D [1] W188626	T [1] W188642
E [1] S188627	U [1] W188643
F [1] W188628	V [1] W188644
G [1] S188629	W [3] W188645
H [1] W188630	X [1] W188646
I [1] W188631	Y [1] W188647
J [1] W188632	Z [1] W188648
K [1] W188633	AA [1] W188649
L [1] W188634	BB [1] S188650
M [1] W188635	CC [1] W188651
N [1] W188636	DD [1] W188652
O [1] W188637	EE [1] W188653
P [1] W188638	FF [1] W188654

# FASTENERS

---

Fasteners are shown in actual size.

Los fijadores son demostrados en su tamaño actual.

Les attaches sont montrées dans l'échelle grandeur.

H181468

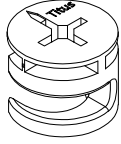

KD Cam

[ 45 ]

H180604

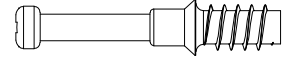

KD Bolt

[ 45 ]

H124395

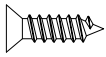

#6 x 1/2"

[ 18 ]

H38169

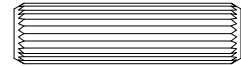

Wood Dowel  
8 x 30mm

[ 57 ]

H26053

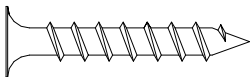

#10 x 1-1/4"

[ 4 ]

H27771

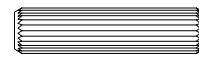

Wood Dowel  
6 x 25mm

[ 5 ]

H158986

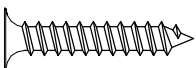

#8 x 1"

[ 5 ]

H160460



M4 x 22mm

[ 1 ]

## FASTENERS

---

Fasteners are shown in actual size.

Los fijadores son demostrados en su tamaño actual.

Les attaches sont montrées dans l'échelle grandeur.

H101725

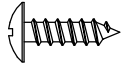

[ 18 ]

#6 x 1/2"

H153031

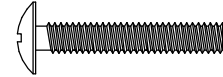

[ 1 ]

M4x25mm

H167433

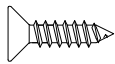

[ 4 ]

#6 x 9/16"

H150019

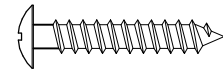

[ 8 ]

#8 x 1"

H23491

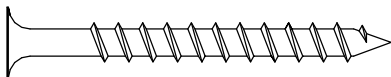

[ 4 ]

#10 x 2"

H35251

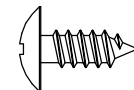

[ 2 ]

#10 x 1/2"

H34174



[ 43 ]

#3 x 3/4"

HARDWARE

---

H149994

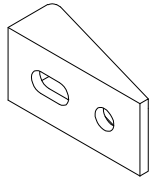

[ 1 ]

Plastic Bracket

H85966

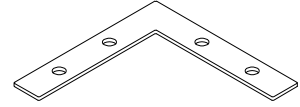

[ 2 ]

Bracket

H160281

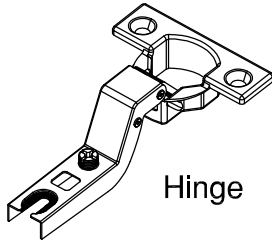

[ 2 ]

Hinge

H160282

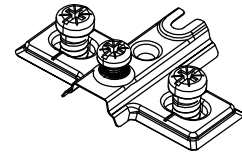

[ 2 ]

Mounting Plate

H137197

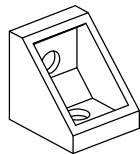

[ 4 ]

Plastic Bracket

H100444

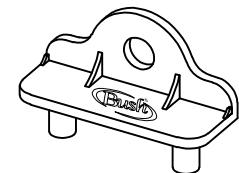

[ 2 ]

Drawer Bracket

H159990



[ 2 ]

Pull

H157530

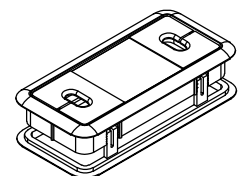

[ 1 ]

Grommet

HARDWARE

H27145  [ 1 ]  
Glue

H149989  [ 1 ]  
Bumper

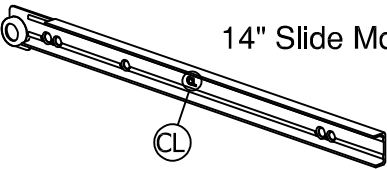
Z89893  14" Slide Mount [ 1 ]

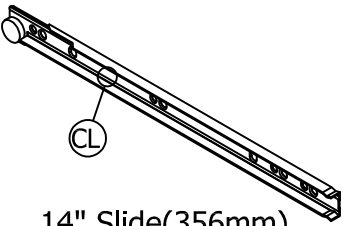
Z35219  14" Slide(356mm) [ 1 ]

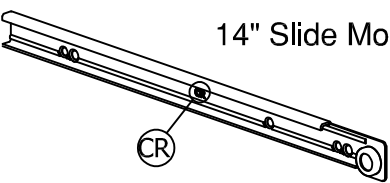
Z89894  14" Slide Mount [ 1 ]

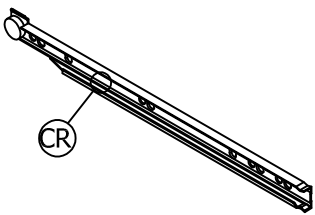
Z35218  14" Slide(356mm) [ 1 ]

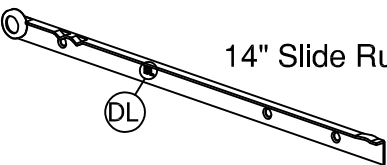
Z89895  14" Slide Runner [ 1 ]

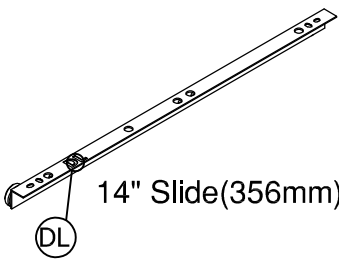
Z35217  14" Slide(356mm) [ 1 ]

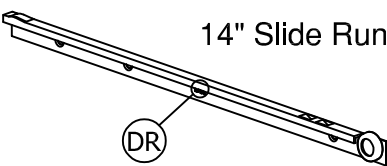
Z89896  14" Slide Runner [ 1 ]

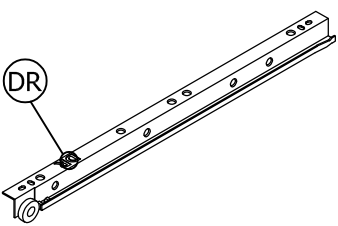
Z35216  14" Slide(356mm) [ 1 ]

HARDWARE

---

H174677

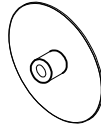

[ 15 ]

Cover Cap

H160399

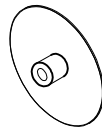

[ 15 ]

Cover Cap

H186180

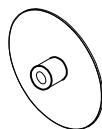

[ 15 ]

Cover Cap

STEP 1

H180604

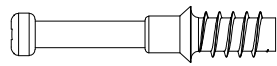

[ 9 ]

KD Bolt

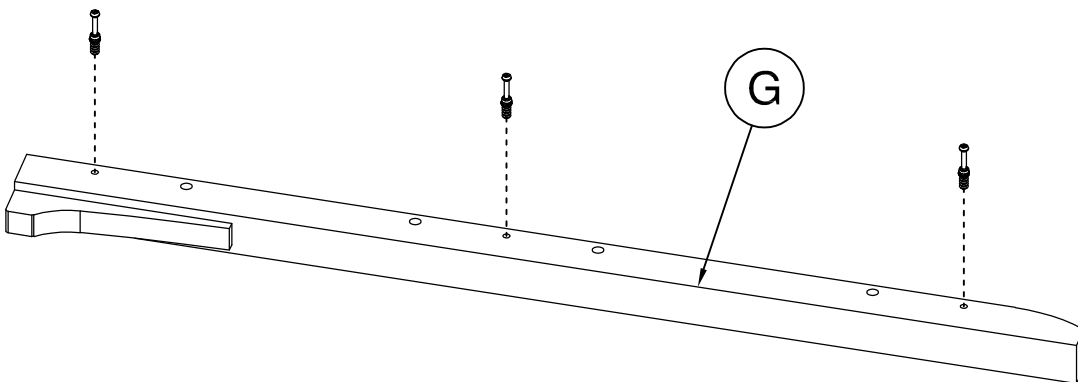
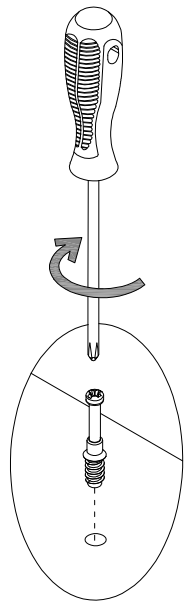
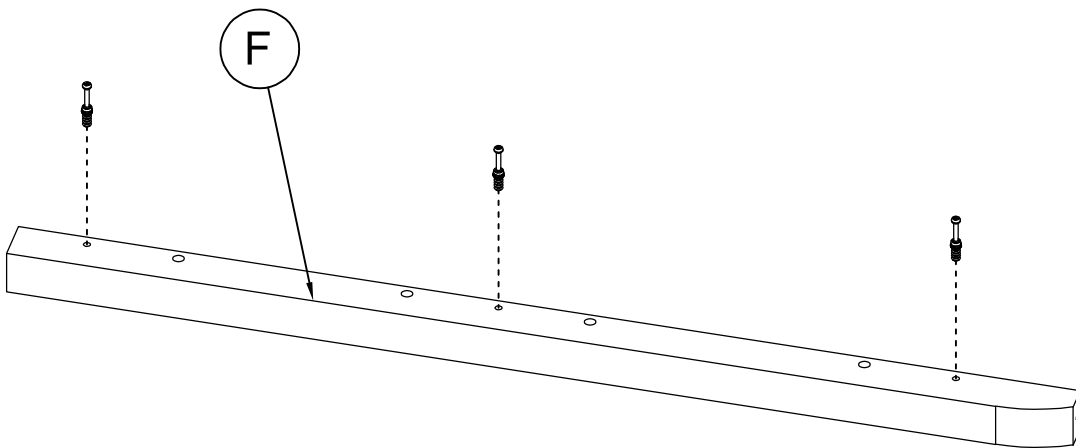
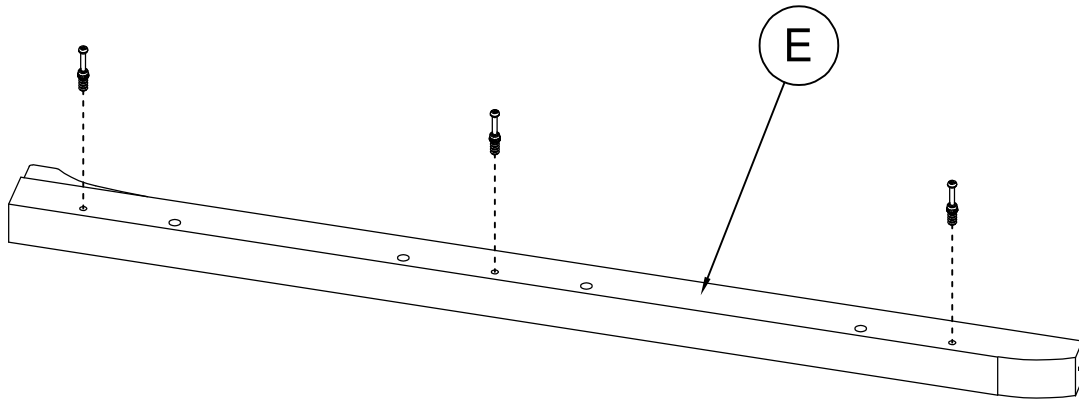

STEP 2

H180604

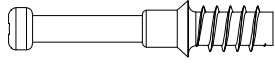

KD Bolt

[ 2 ]

H124395

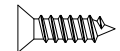

#6 x 1/2"

[ 3 ]

H38169



Wood Dowel  
8 x 30mm

[ 6 ]

H27145

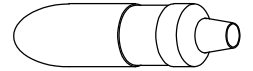

Glue

Z35219

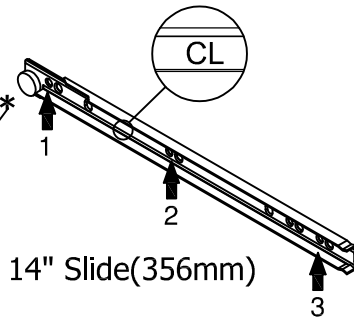

[ 1 ]

Orientation  
Orientación  
L'orientation

14" Slide(356mm)

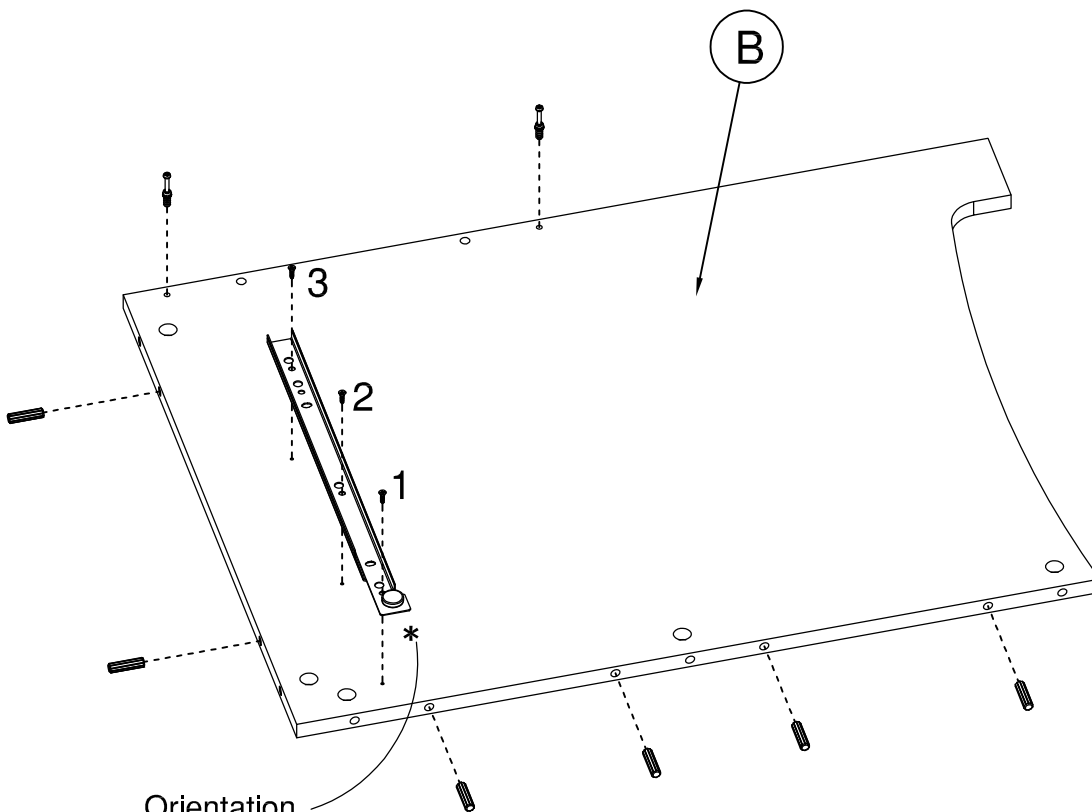

Orientation  
Orientación  
L'orientation

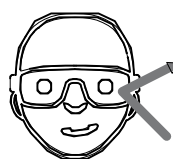

Safety glasses  
Gafas de seguridad  
Lunettes de protection

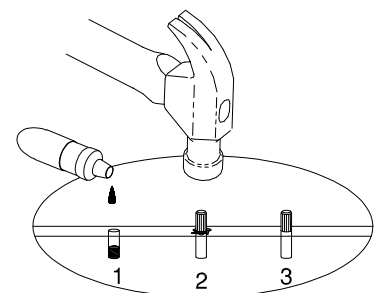

# STEP 3

H181468

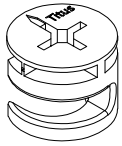

[ 3 ]

KD Cam

H160399

H174677

H186180



[ 3 ]

Cover Cap

Push the KD cam all the way into the hole before tightening.  
Empujar la leva KD hasta el final en el agujero antes de apretar.  
Pousser la came de KD tout le chemin dans le trou avant de serrer.

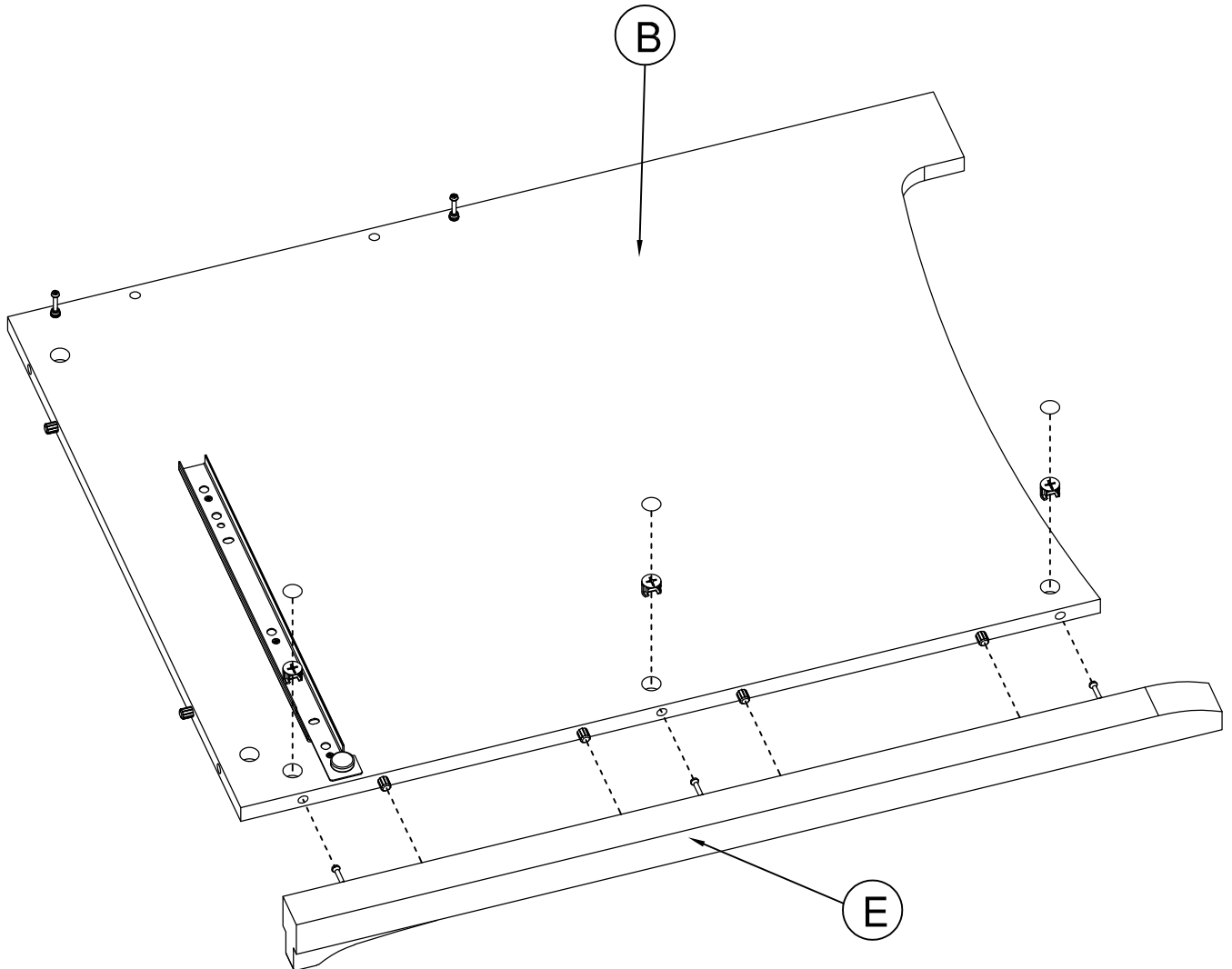
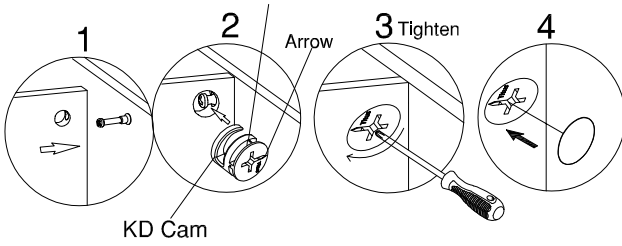

STEP 4

H38169

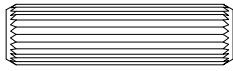

Wood Dowel  
8 x 30mm

[ 6 ]

H27145

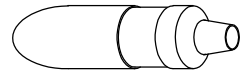

Glue

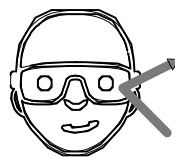
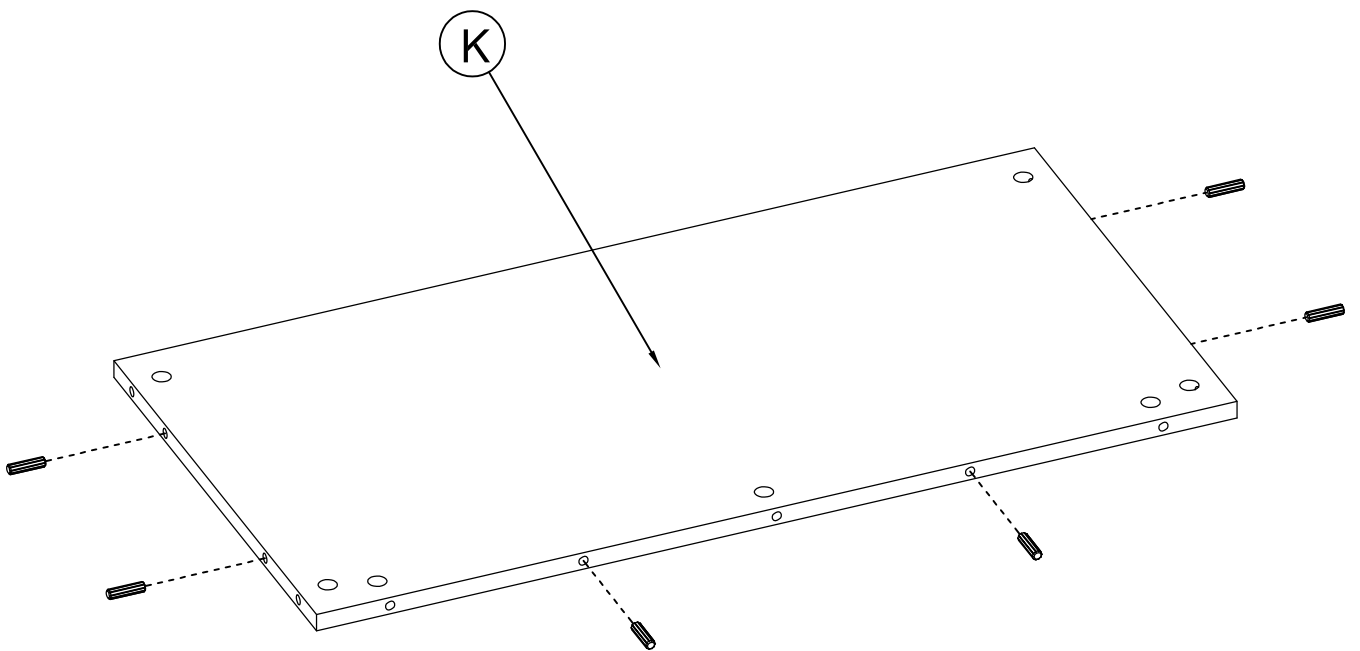

Safety glasses  
Gafas de seguridad  
Lunettes de protection

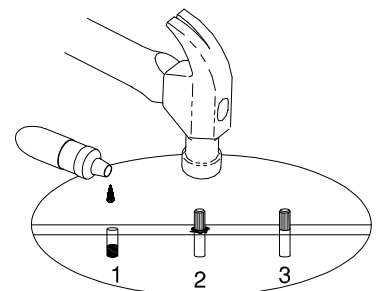

STEP 5

H181468

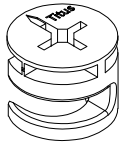

[ 2 ]

KD Cam

Push the KD cam all the way into the hole before tightening.  
Empujar la leva KD hasta el final en el agujero antes de apretar.  
Pousser la came de KD tout le chemin dans le trou avant de serrer.

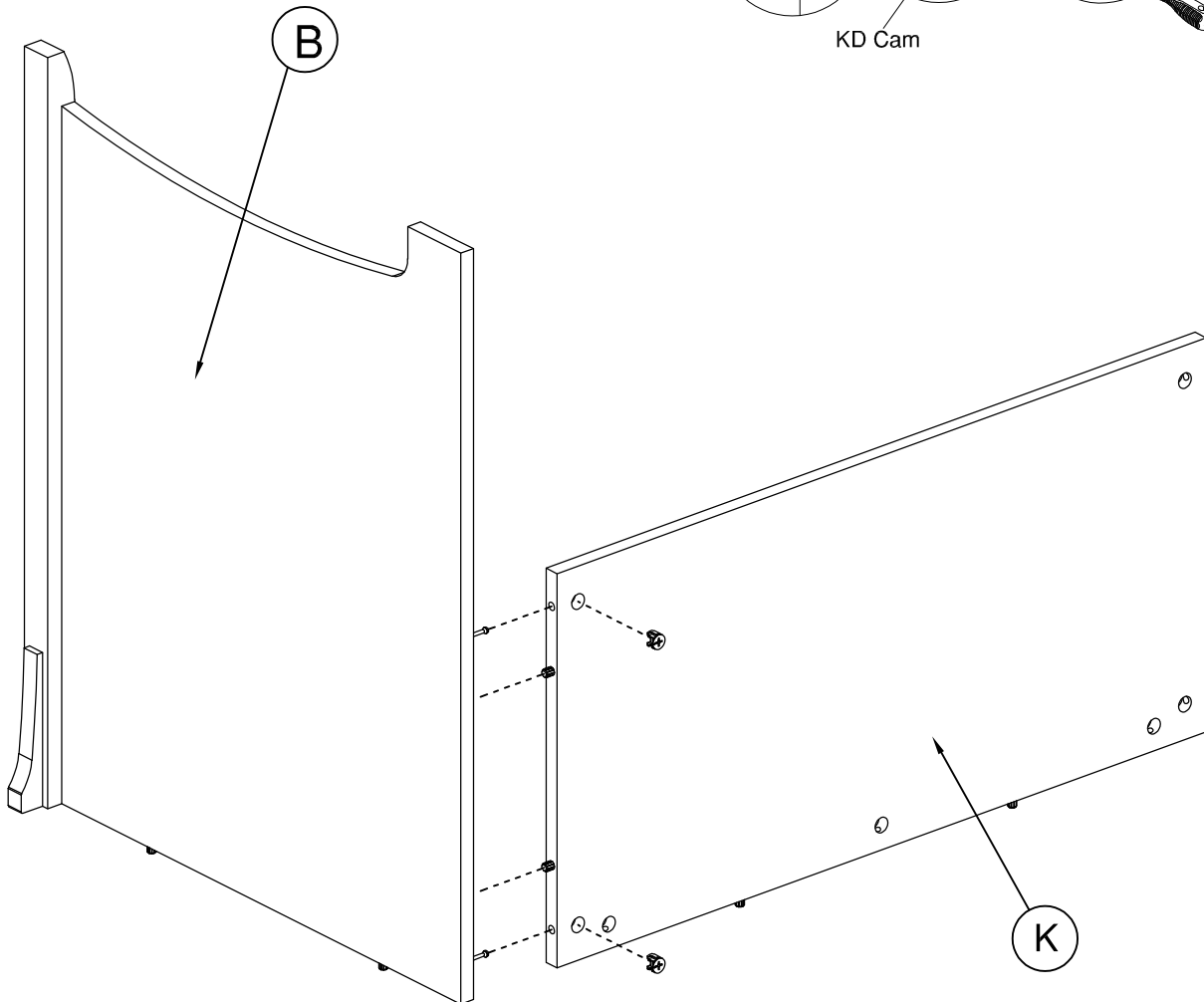
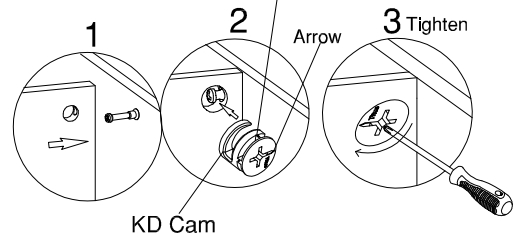

An assistant is required.  
Es necesario un ayudante.  
Un assistant est nécessaire.



# STEP 7

H181468

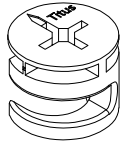

[ 3 ]

KD Cam

H160399  
H174677  
H186180

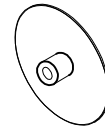

[ 1 ]

Cover Cap

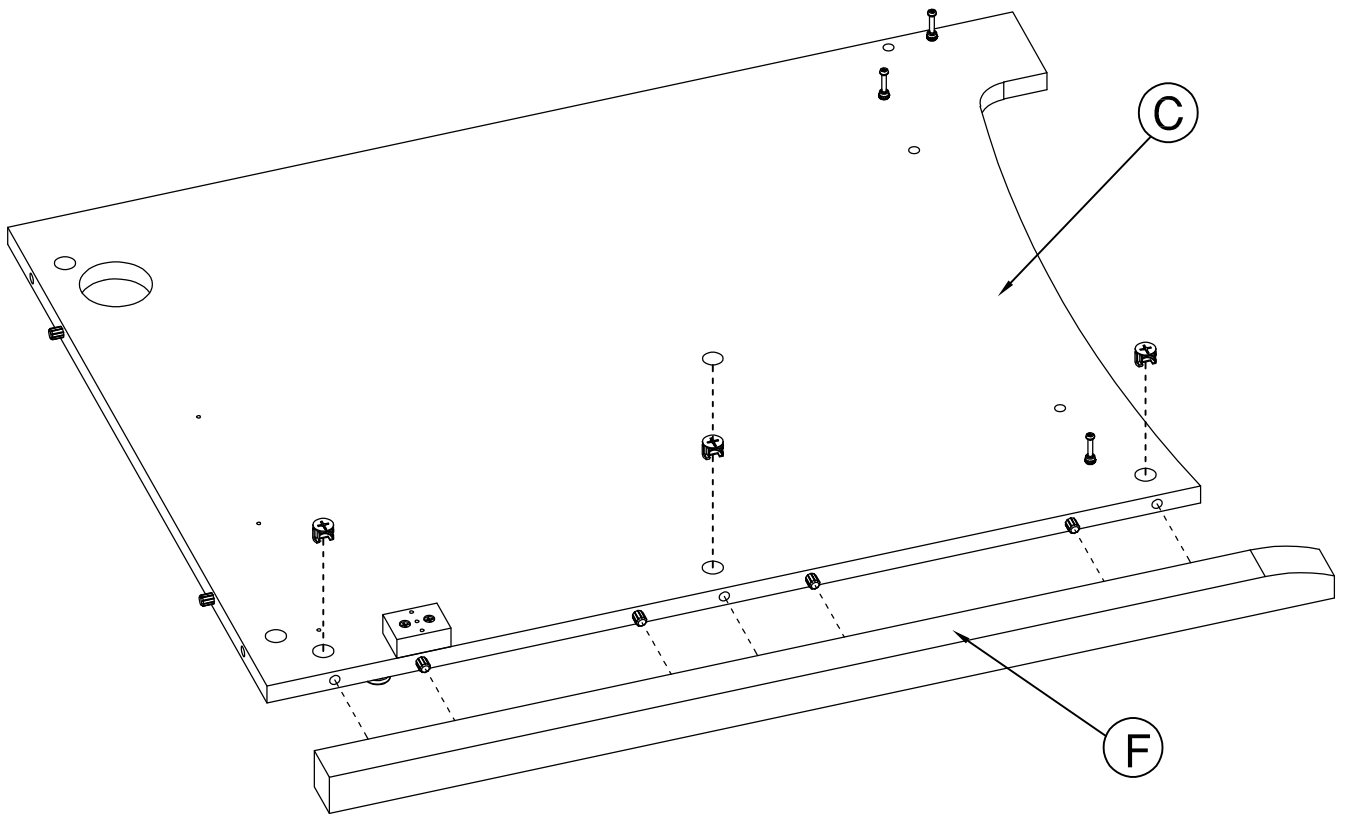

Push the KD cam all the way into the hole before tightening.  
Empujar la leva KD hasta el final en el agujero antes de apretar.  
Pousser la came de KD tout le chemin dans le trou avant de serrer.

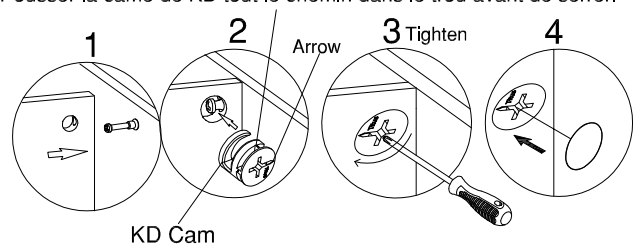

STEP 8

H101725

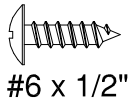

[ 2 ]

H158986

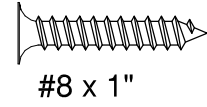

[ 3 ]

H149994

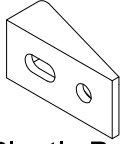

[ 1 ]

Plastic Bracket

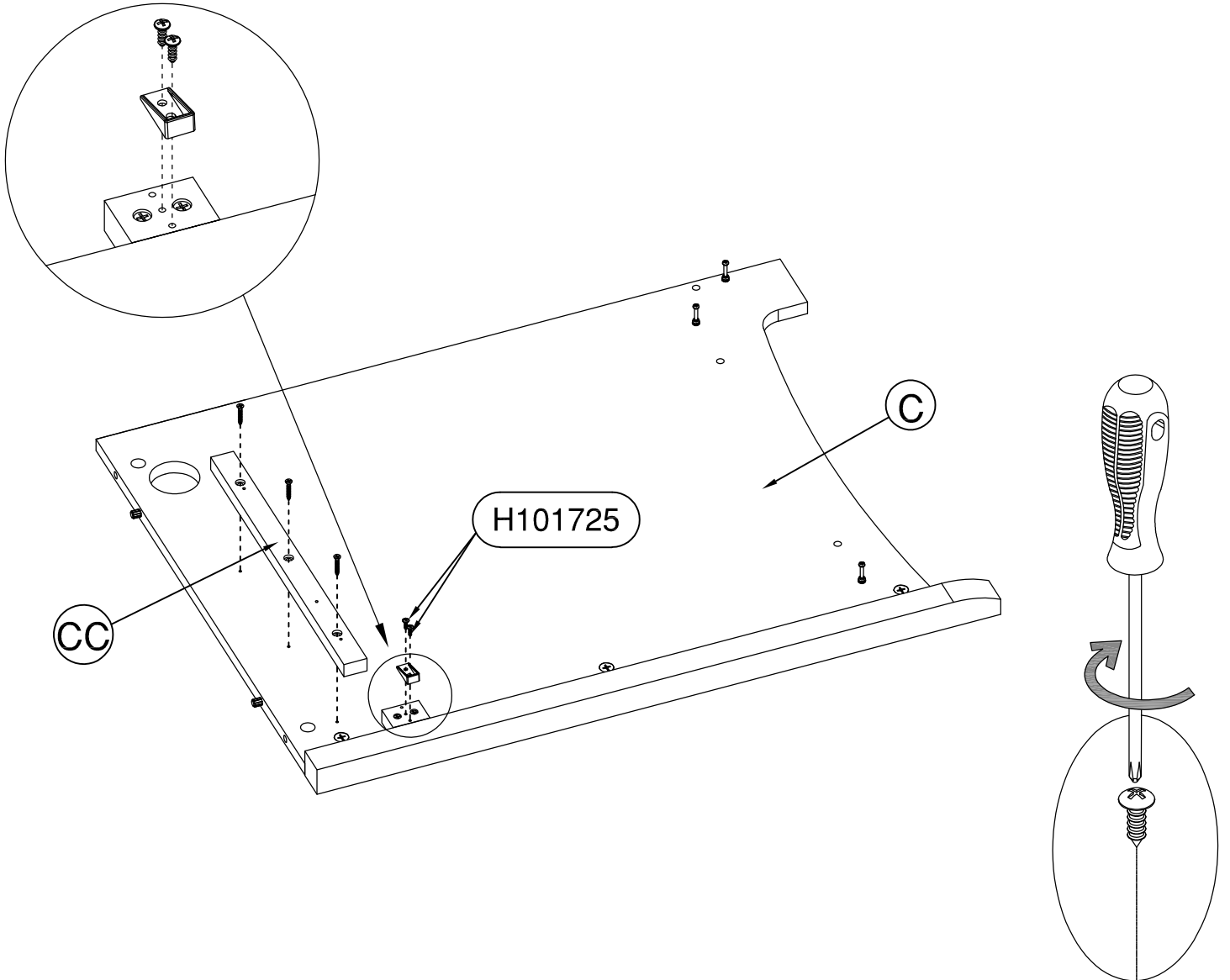

STEP 9

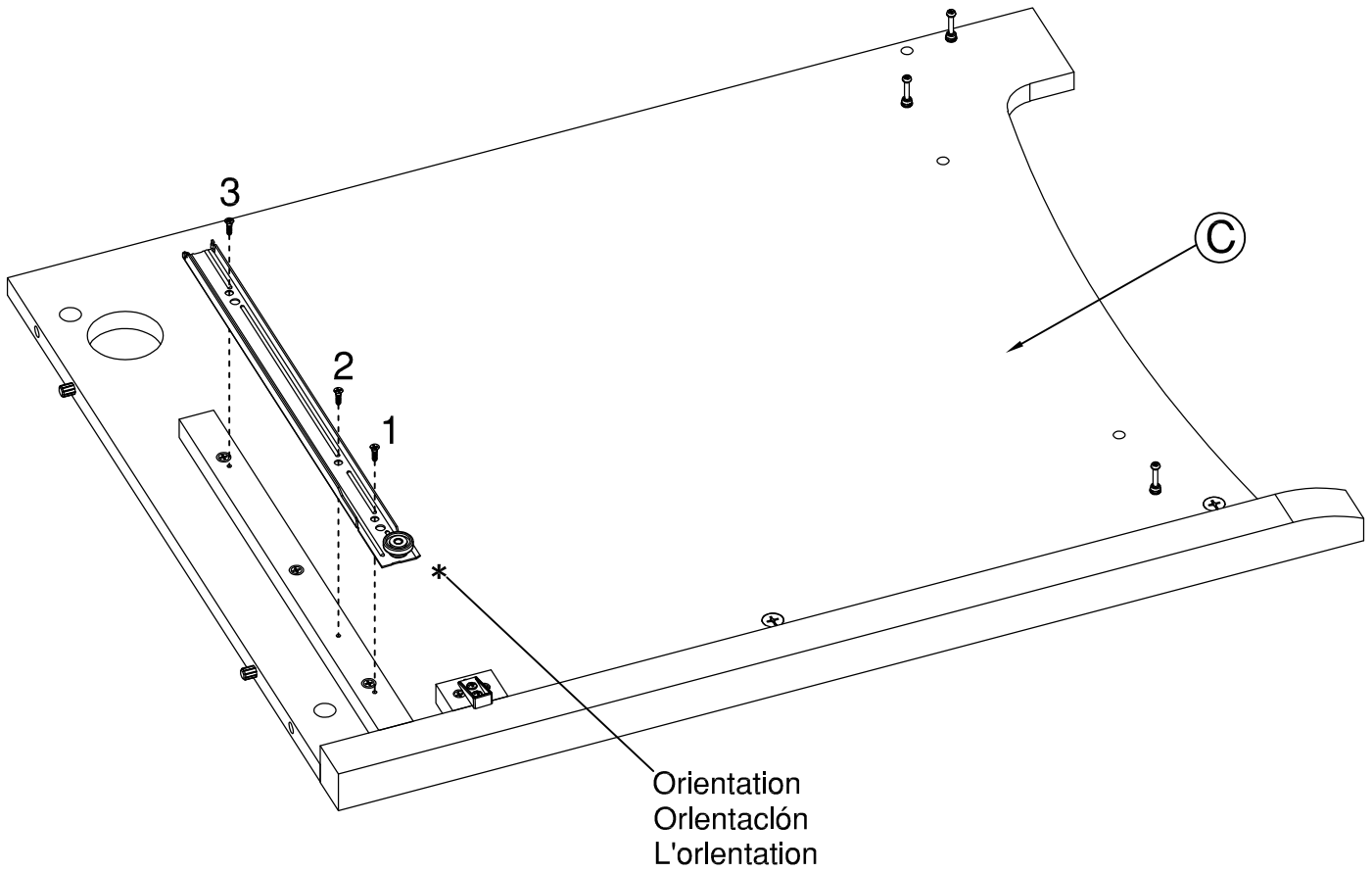
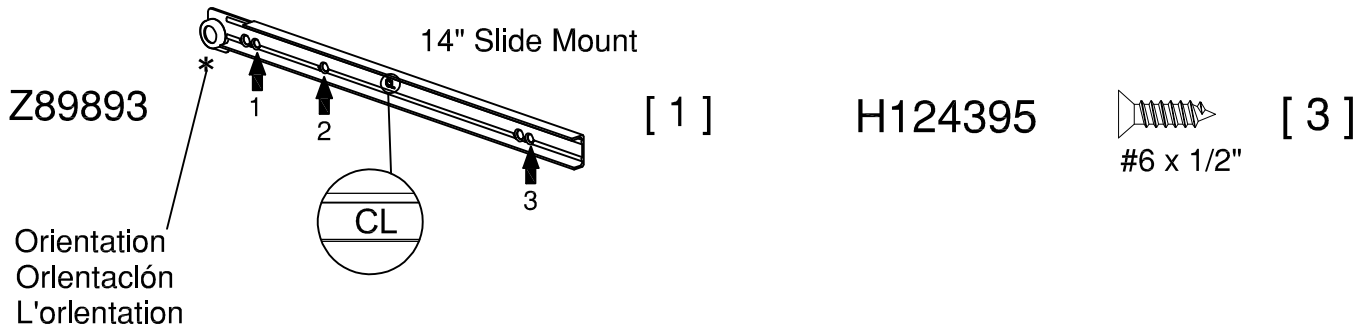

STEP 10

H181468

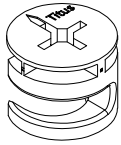

KD Cam

[ 2 ]

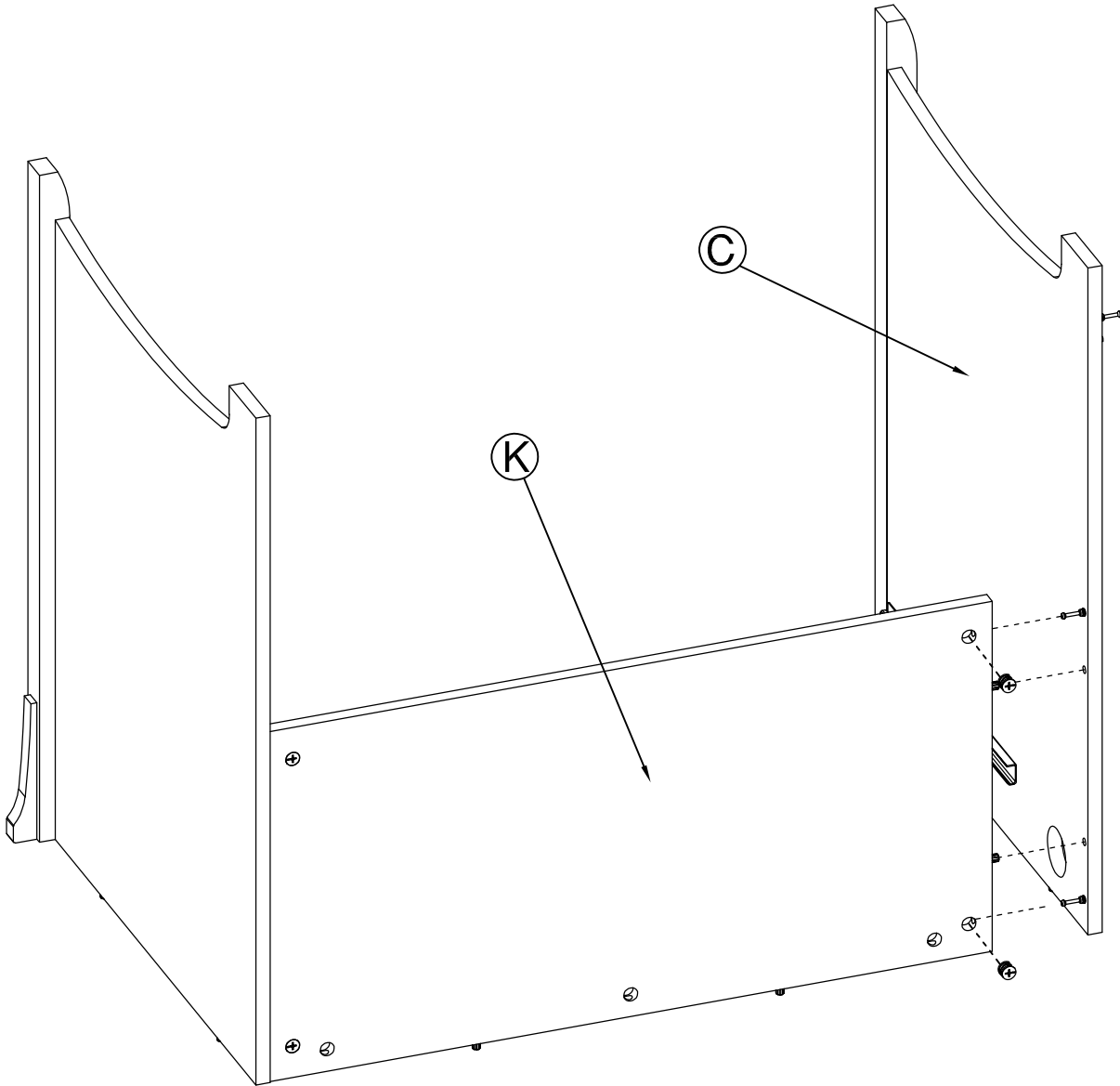

Push the KD cam all the way into the hole before tightening.  
Empujar la leva KD hasta el final en el agujero antes de apretar.  
Pousser la came de KD tout le chemin dans le trou avant de serrer.

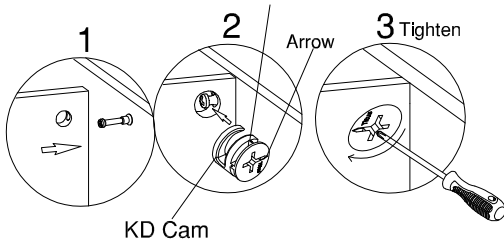

# STEP 11

H180604

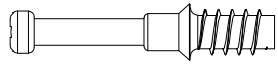

[ 2 ]

KD Bolt

H27145

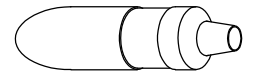

Glue

H38169

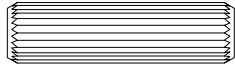

[ 9 ]

Wood Dowel  
8 x 30mm

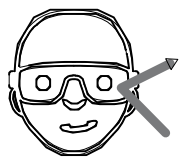
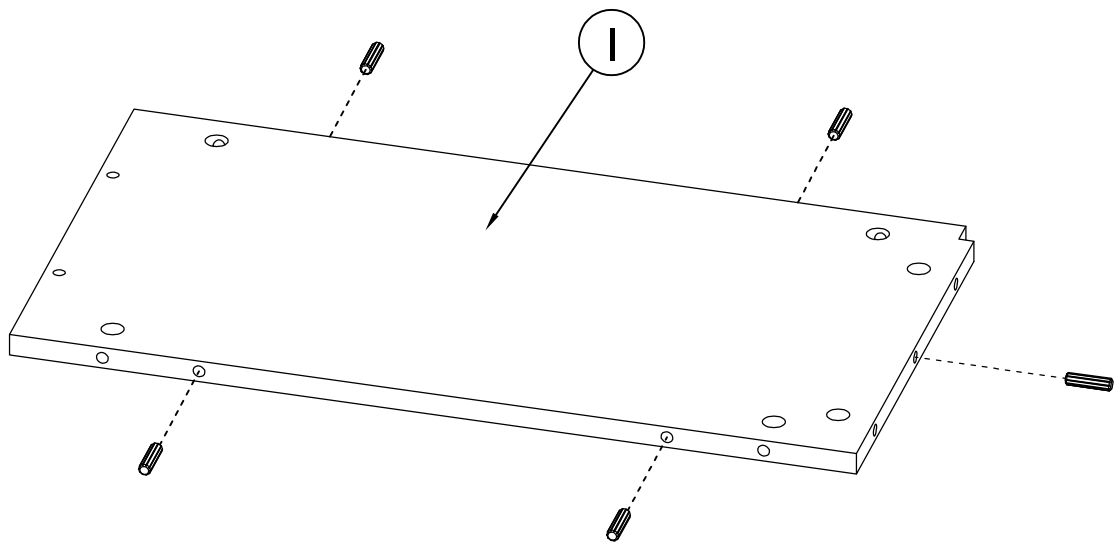

Safety glasses  
Gafas de seguridad  
Lunettes de protection

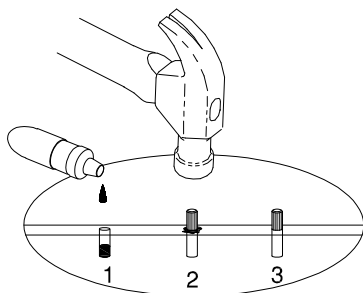
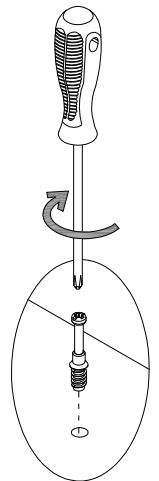
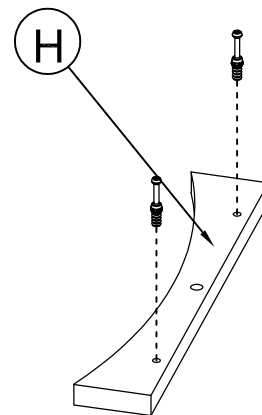
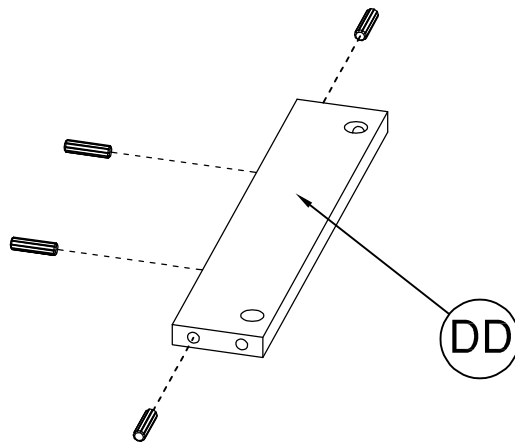

STEP 12

H181468

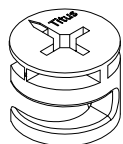

[ 2 ]

KD Cam

Finished Side  
Lado Terminada  
Cote Fini

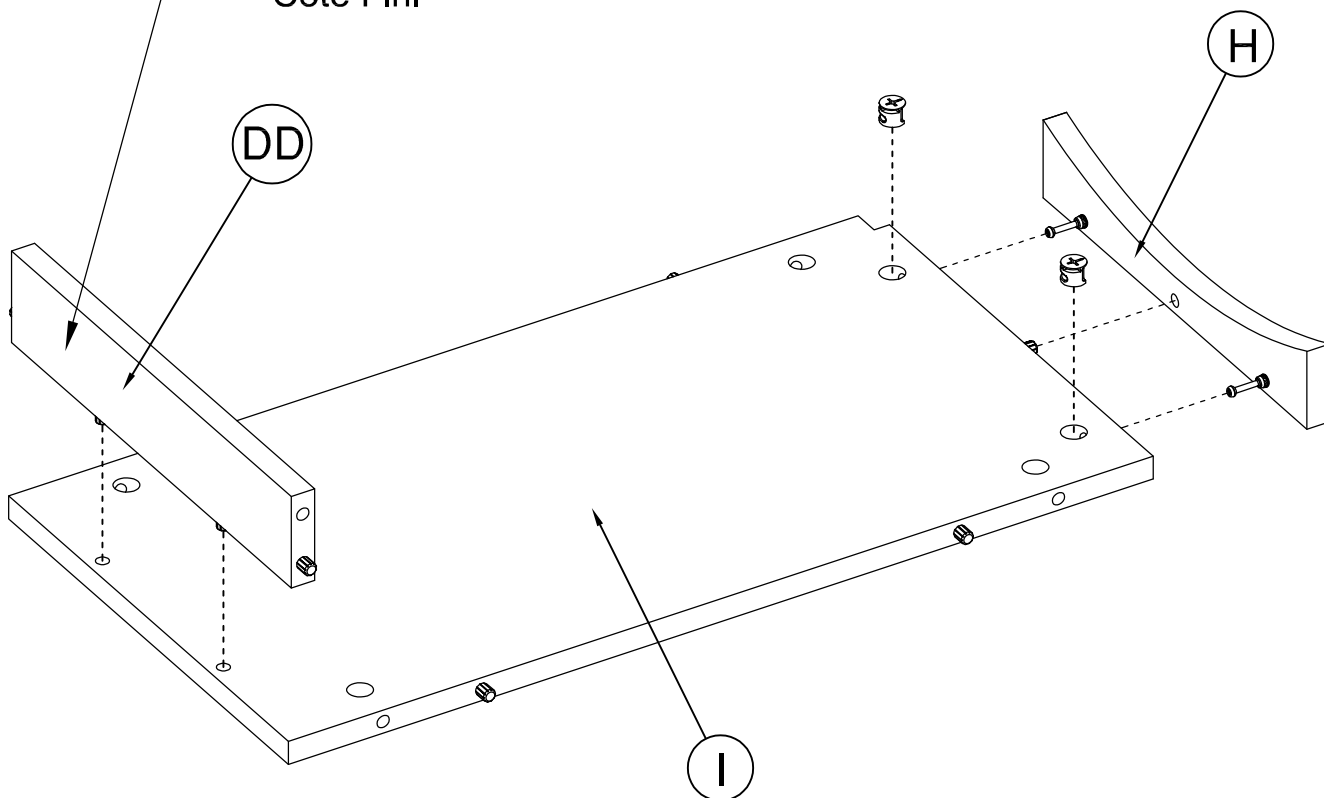

Push the KD cam all the way into the hole before tightening.  
Empujar la leva KD hasta el final en el agujero antes de apretar.  
Pousser la came de KD tout le chemin dans le trou avant de serrer.

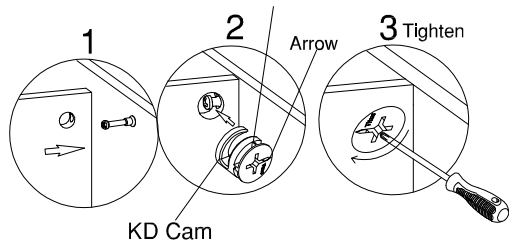

STEP 13

H180604

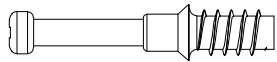

KD Bolt

[ 3 ]

H160282

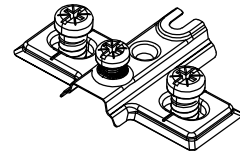

Mounting Plate

[ 2 ]

H38169

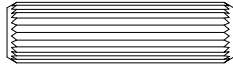

Wood Dowel  
8 x 30mm

[ 6 ]

H27145

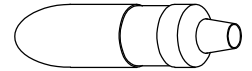

Glue

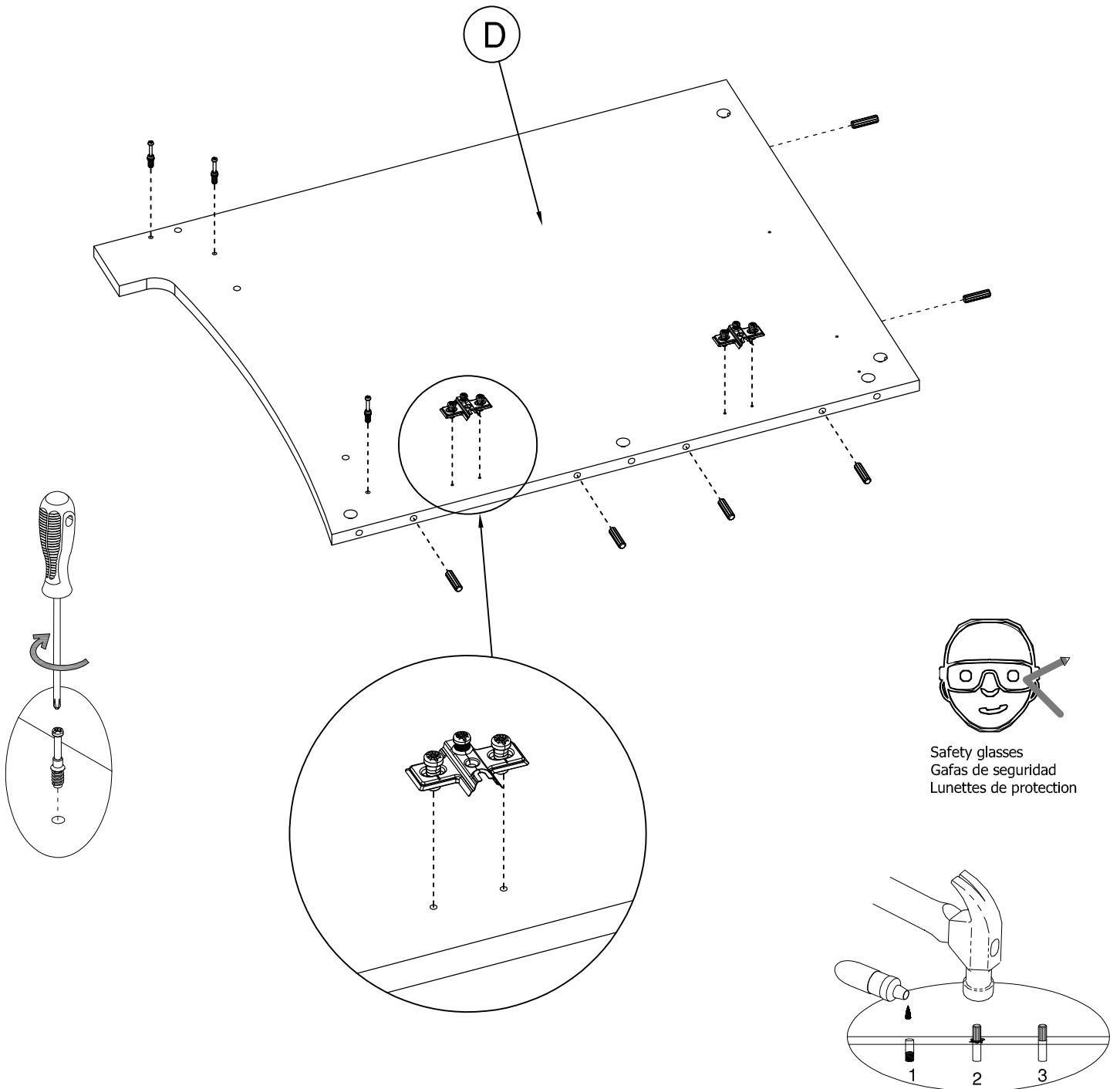

STEP 14

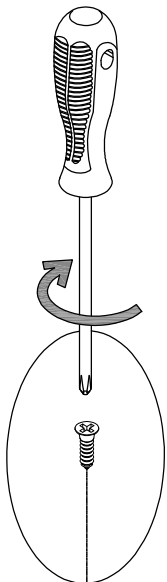
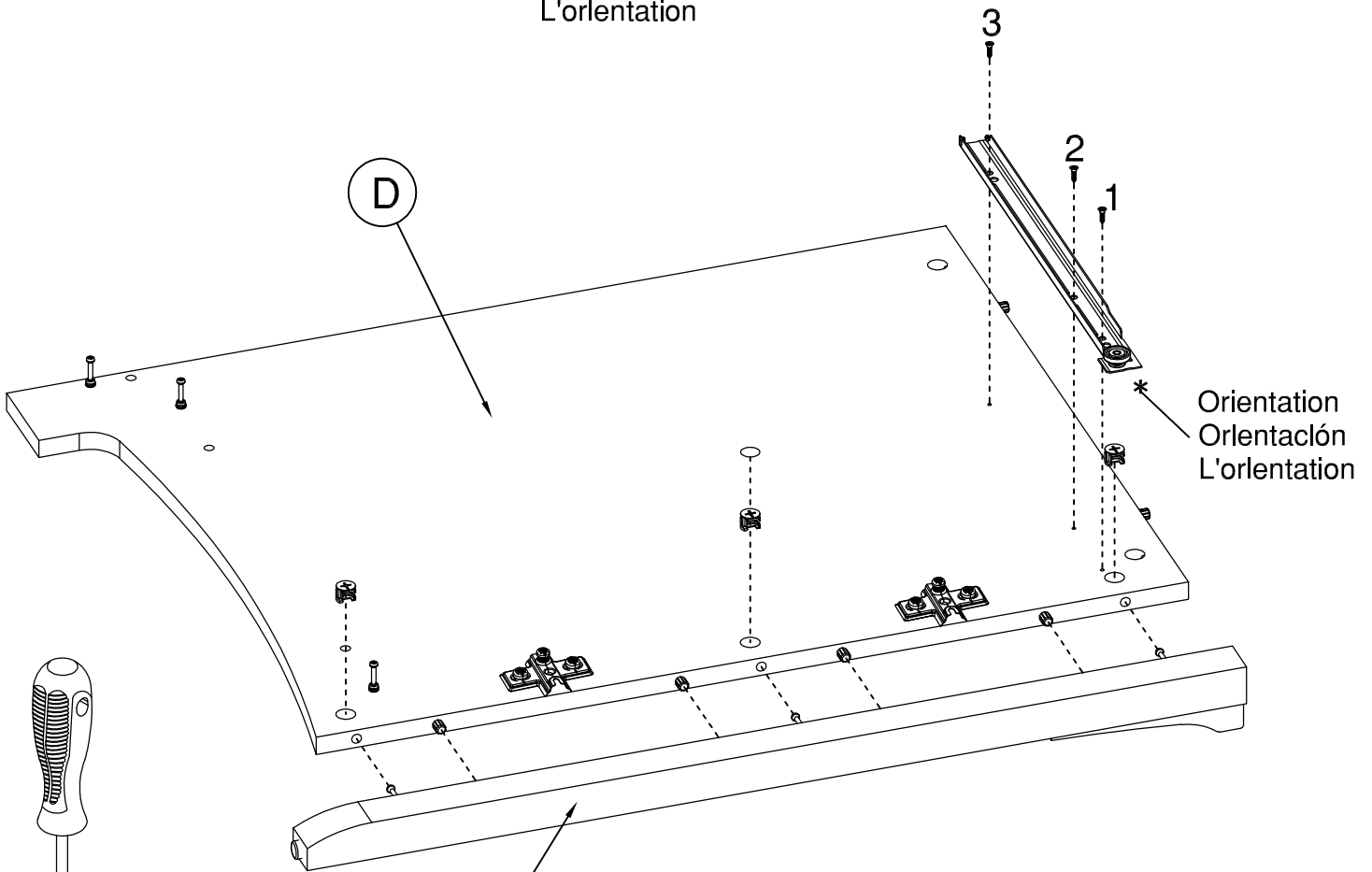
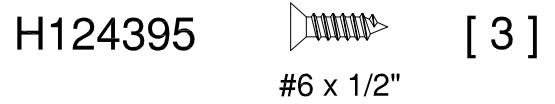
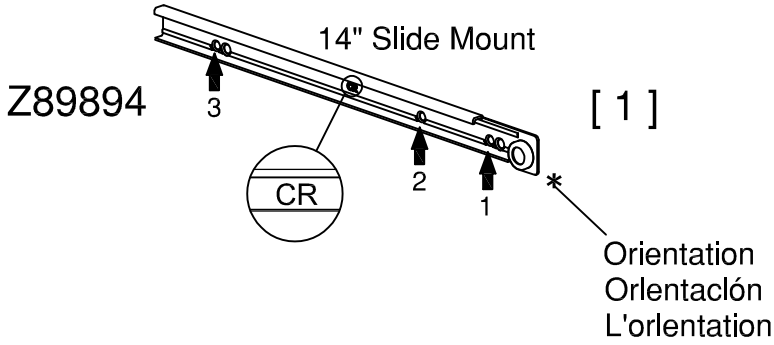
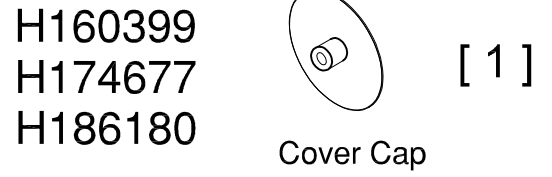
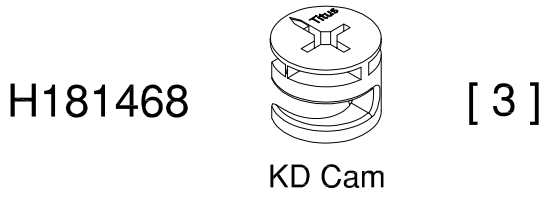

Push the KD cam all the way into the hole before tightening.  
 Empujar la leva KD hasta el final en el agujero antes de apretar.  
 Pousser la came de KD tout le chemin dans le trou avant de serrer.

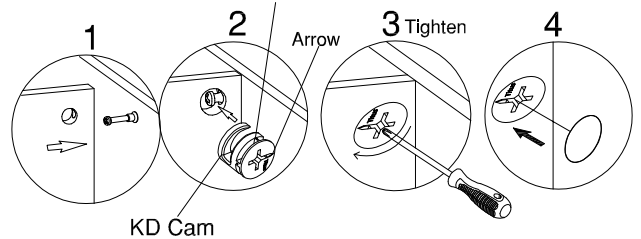

# STEP 15

H181468

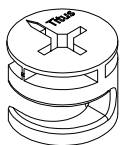

[ 6 ]

KD Cam

Push the KD cam all the way into the hole before tightening.  
Empujar la leva KD hasta el final en el agujero antes de apretar.  
Pousser la came de KD tout le chemin dans le trou avant de serrer.

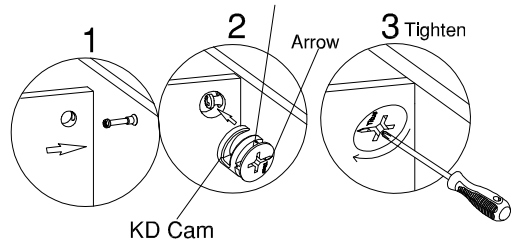

An assistant is required.  
Es necesario un ayudante.  
Un assistant est nécessaire.

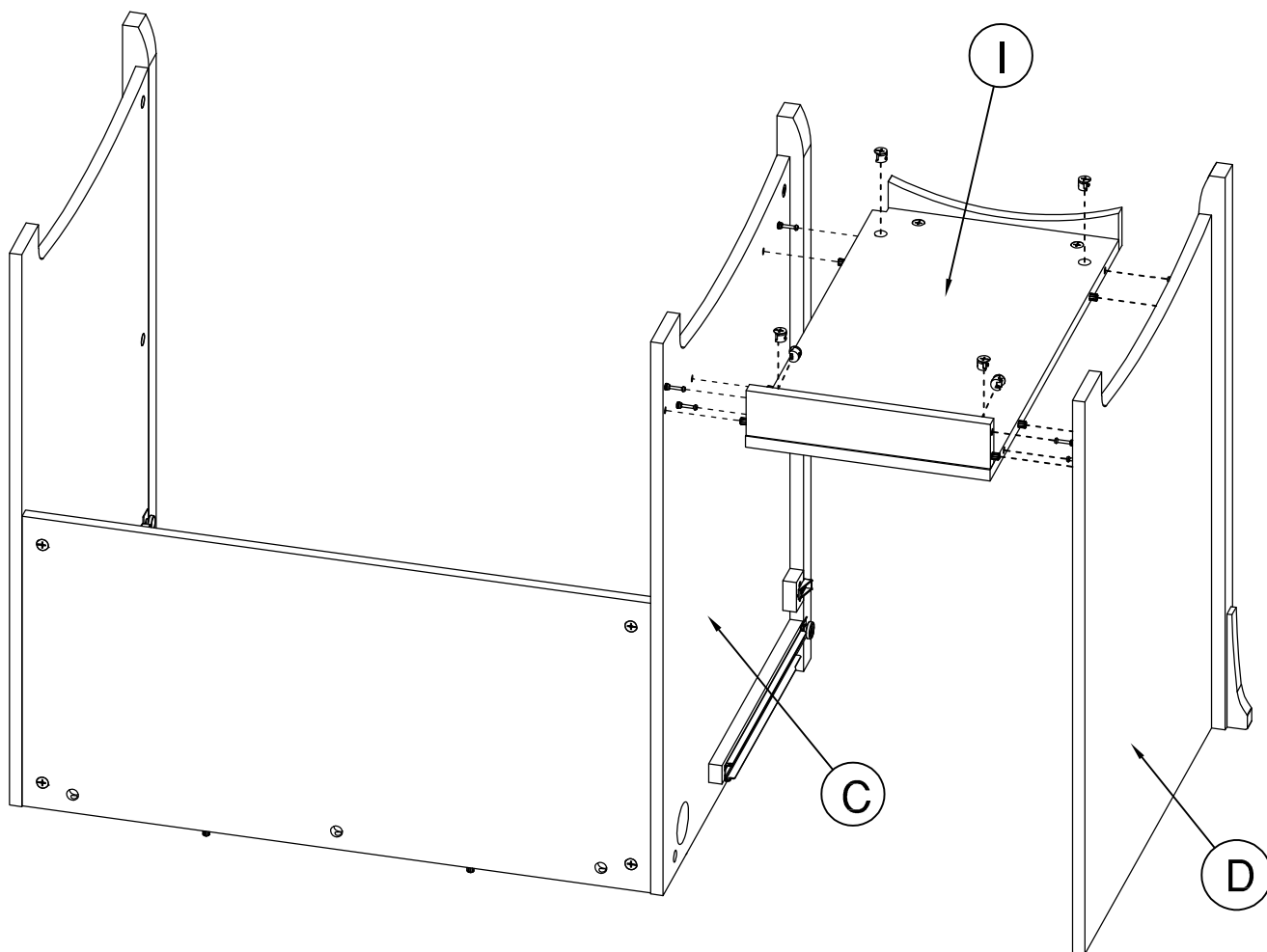

STEP 16

H180604

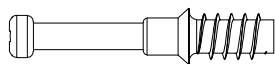

KD Bolt

[ 9 ]

H157530

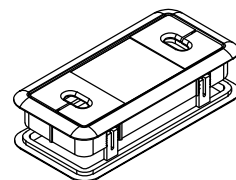

Grommet

[ 1 ]

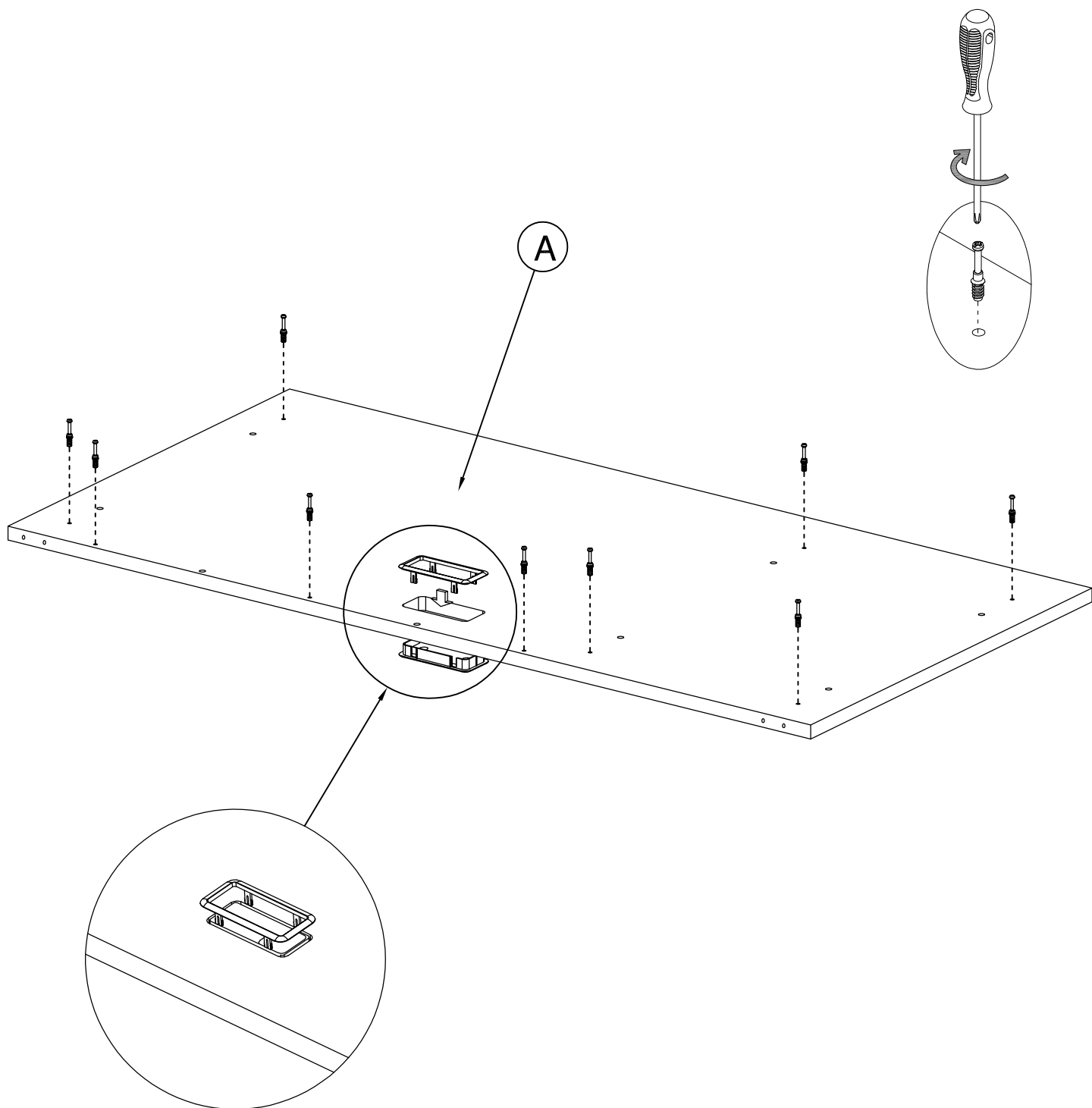

# STEP 17

H181468

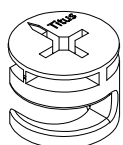

KD Cam

[ 9 ]

H160399

H174677

H186180



Cover Cap

[ 2 ]

H149989



Bumper

[ 1 ]

Push the KD cam all the way into the hole before tightening.  
Empujar la leva KD hasta el final en el agujero antes de apretar.  
Pousser la came de KD tout le chemin dans le trou avant de serrer.

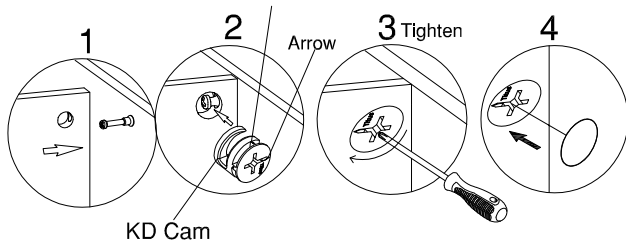

An assistant is required.  
Es necesario un ayudante.  
Un assistant est nécessaire.

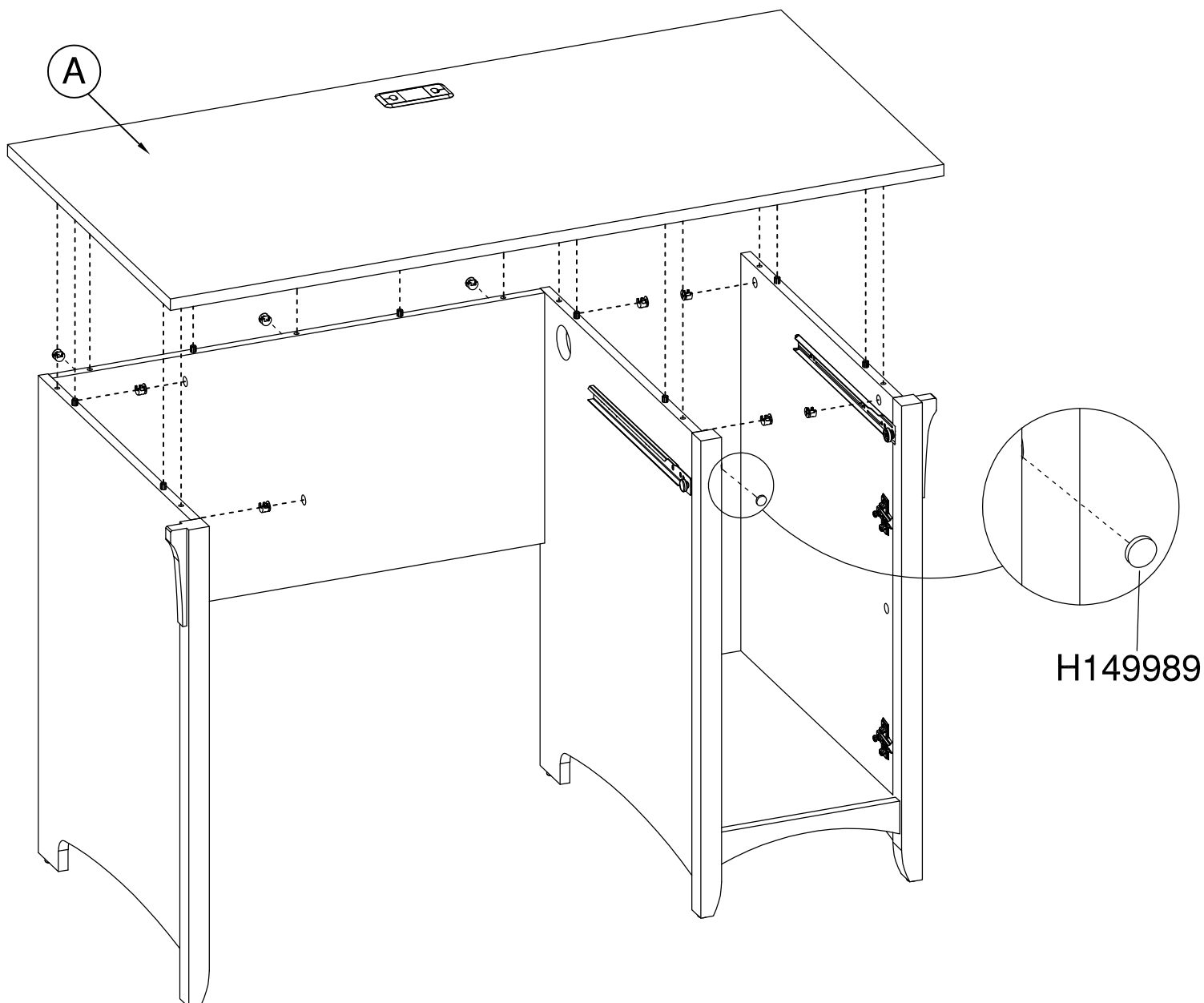

STEP 18

H34174



[ 19 ]

#3 x 3/4"

Center the back panel so that the back panel do not stick past the edge of the unit.  
Centrez le panneau arrière de manière à ce qu'il ne reste pas au-delà du bord de l'appareil.  
Centre el panel posterior de modo que el panel posterior no se pegue más allá del borde de la unidad.

An assistant is required.  
Es necesario un ayudante.  
Un assistant est nécessaire.

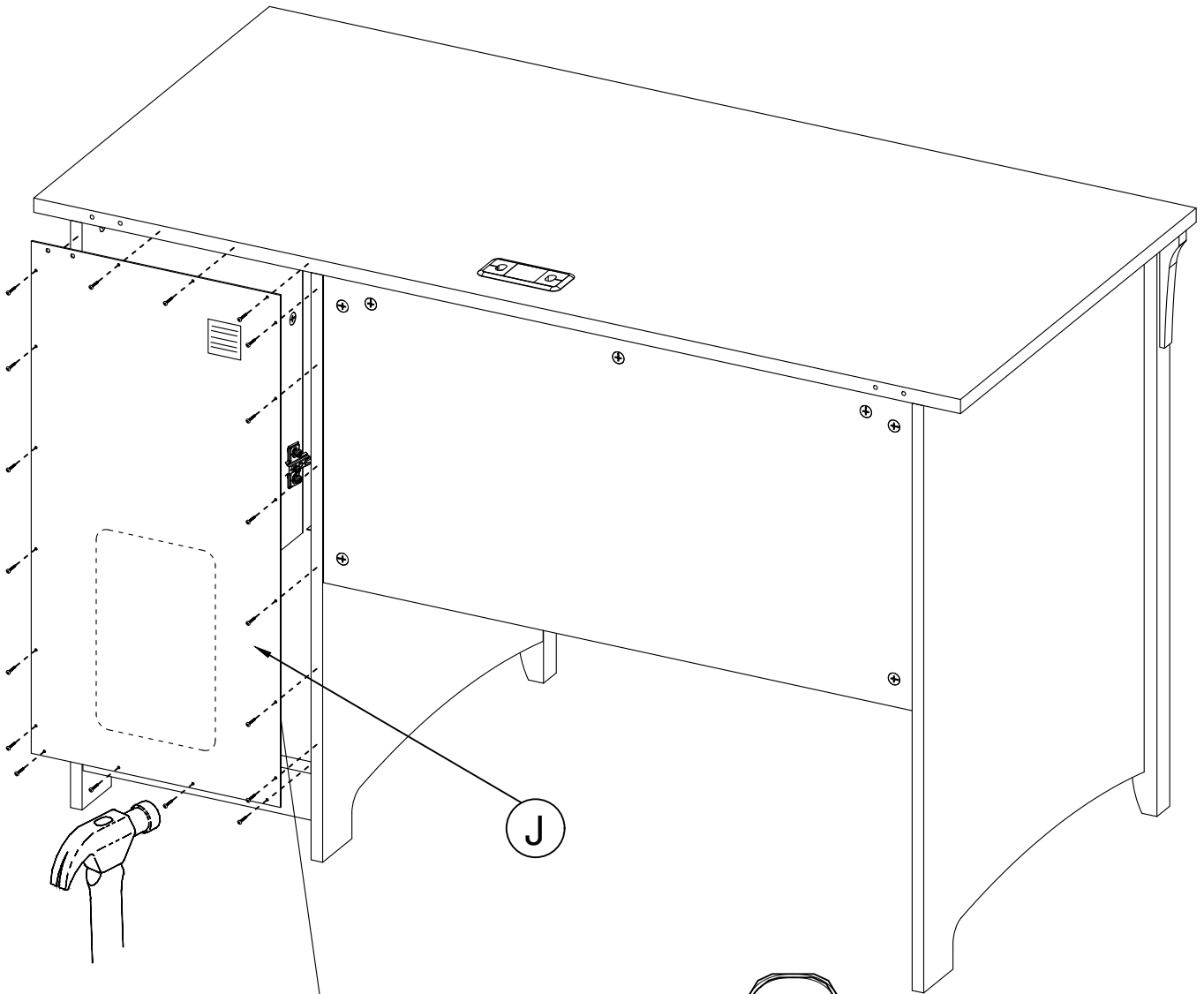

Grain to inside  
Grano para el interior  
Grain de l'intérieur

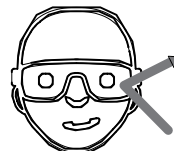

Safety glasses  
Gafas de seguridad  
Lunettes de protection

STEP 19

H160281

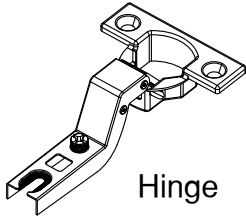

Hinge

[ 2 ]

H167433

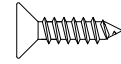

#6 x 9/16"

[ 4 ]

H153031

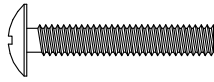

M4x25mm

[ 1 ]

H159990

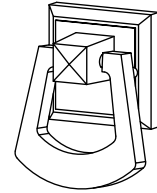

Pull

[ 1 ]

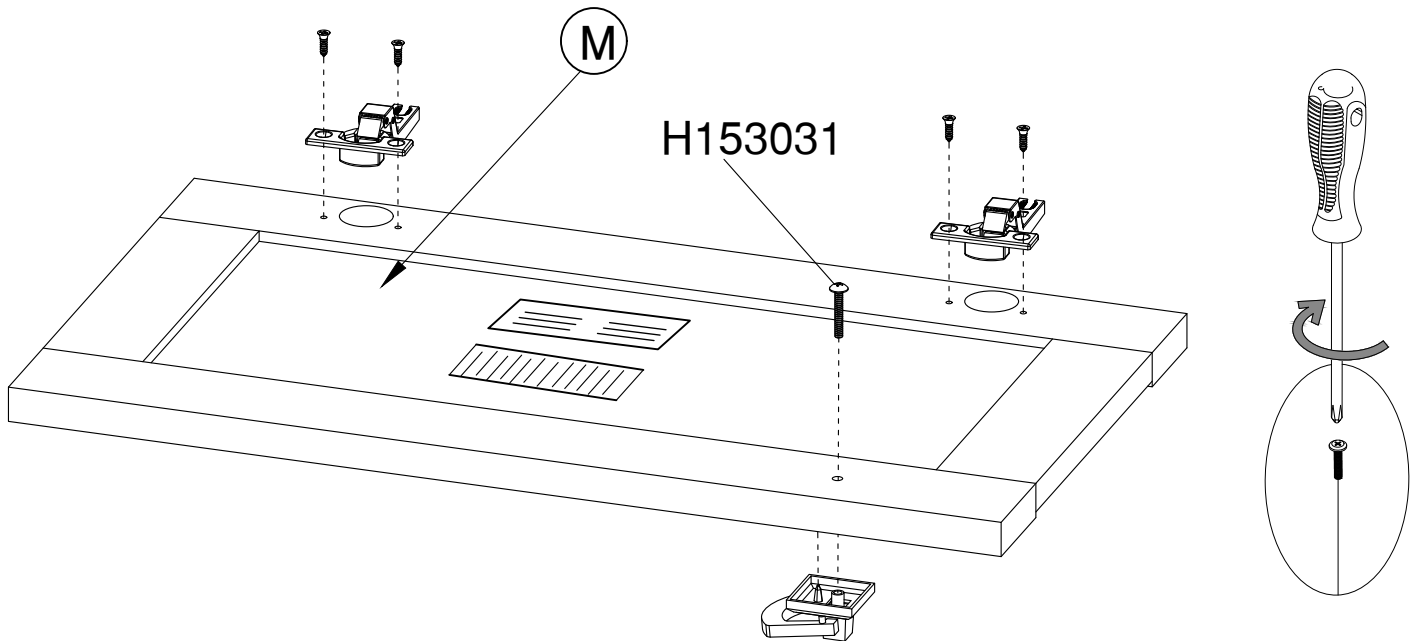

WARNING

**Caution, restricting airflow may result in equipment overheating.**

Vent hole punch outs must be removed to provide adequate venting and cooling of electronic equipment. If power exceeds a maximum recommended wattage of 400 W per shelf location, the door must be left open when in use. Failure to do so could restrict airflow and may result in equipment overheating.

**Precaución, la restricción del flujo de aire puede provocar el sobrecalentamiento del equipo.**

Las perforaciones de los orificios de ventilación deben retirarse para proporcionar ventilación y enfriamiento adecuados de los equipos electrónicos. Si la potencia excede un va taje máximo recomendado de 400 W por ubicación de estante, la puerta debe dejarse abierta cuando esté en uso. De lo contrario, se podría restringir el flujo de aire y el equipo podría sobrecalentarse.

**Attention, la limitation du débit d'air peut entraîner une surchauffe de l'équipement.**

Les perforations des trous d'évent doivent être retirées pour permettre une ventilation et un refroidissement adéquats de l'équipement électronique. Si la puissance dépasse une puissance maximale recommandée de 400 W par emplacement, la porte doit rester ouverte lors de son utilisation. Si vous ne le faites pas, cela pourrait limiter le flux d'air et entraîner une surchauffe de l'équipement.

WATCH VIDEO



Install and adjust hinges

**Installation / instalación / installation**

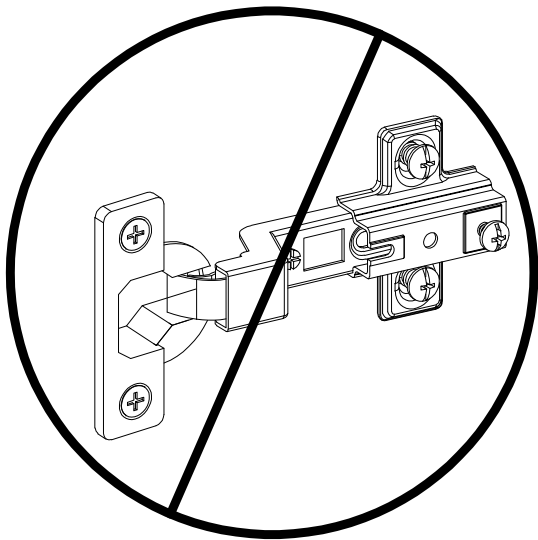
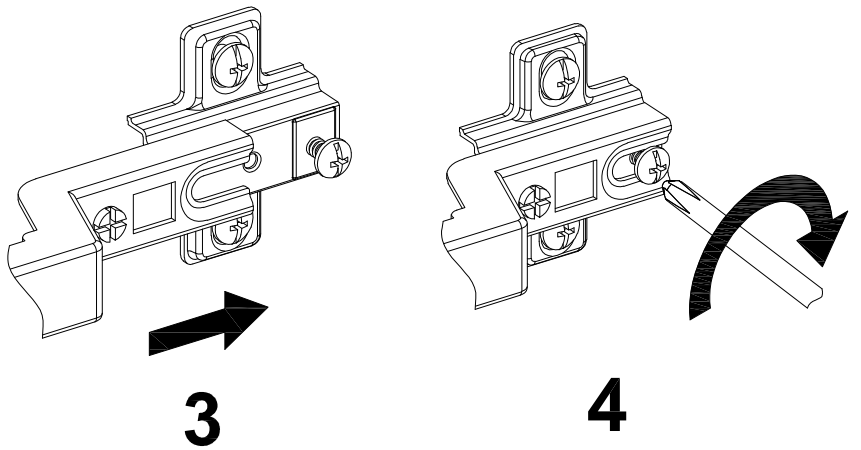
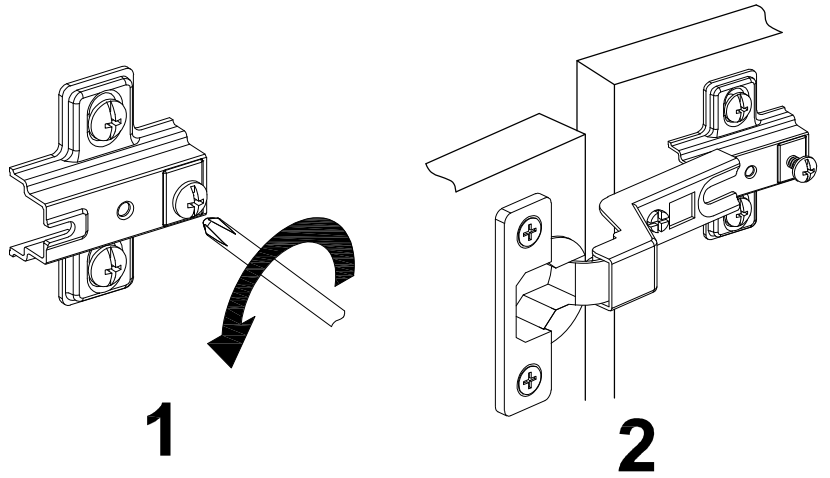

**DO NOT Insert Hinge beneath mount**

**Adjustment / ajuste / ajustement**

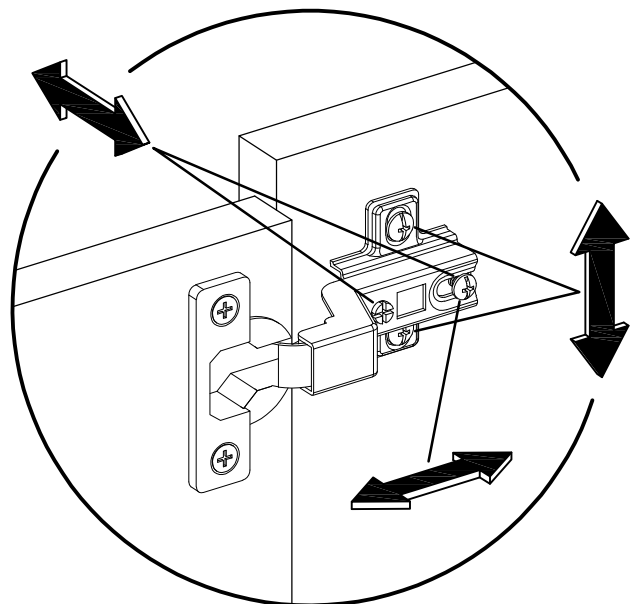
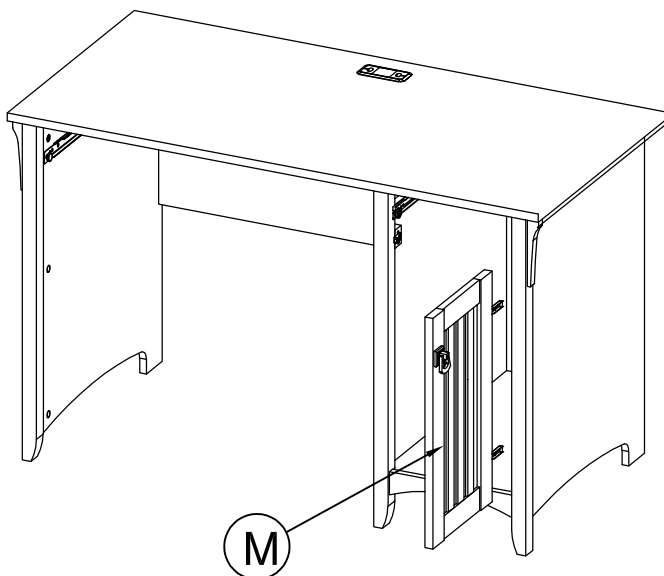

STEP 21

H26053

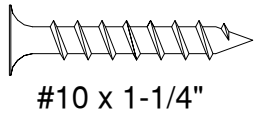

[ 4 ]

H35251

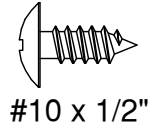

[ 2 ]

H101725

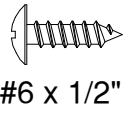

[ 4 ]

H100444

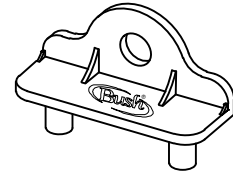

[ 2 ]

Drawer Bracket

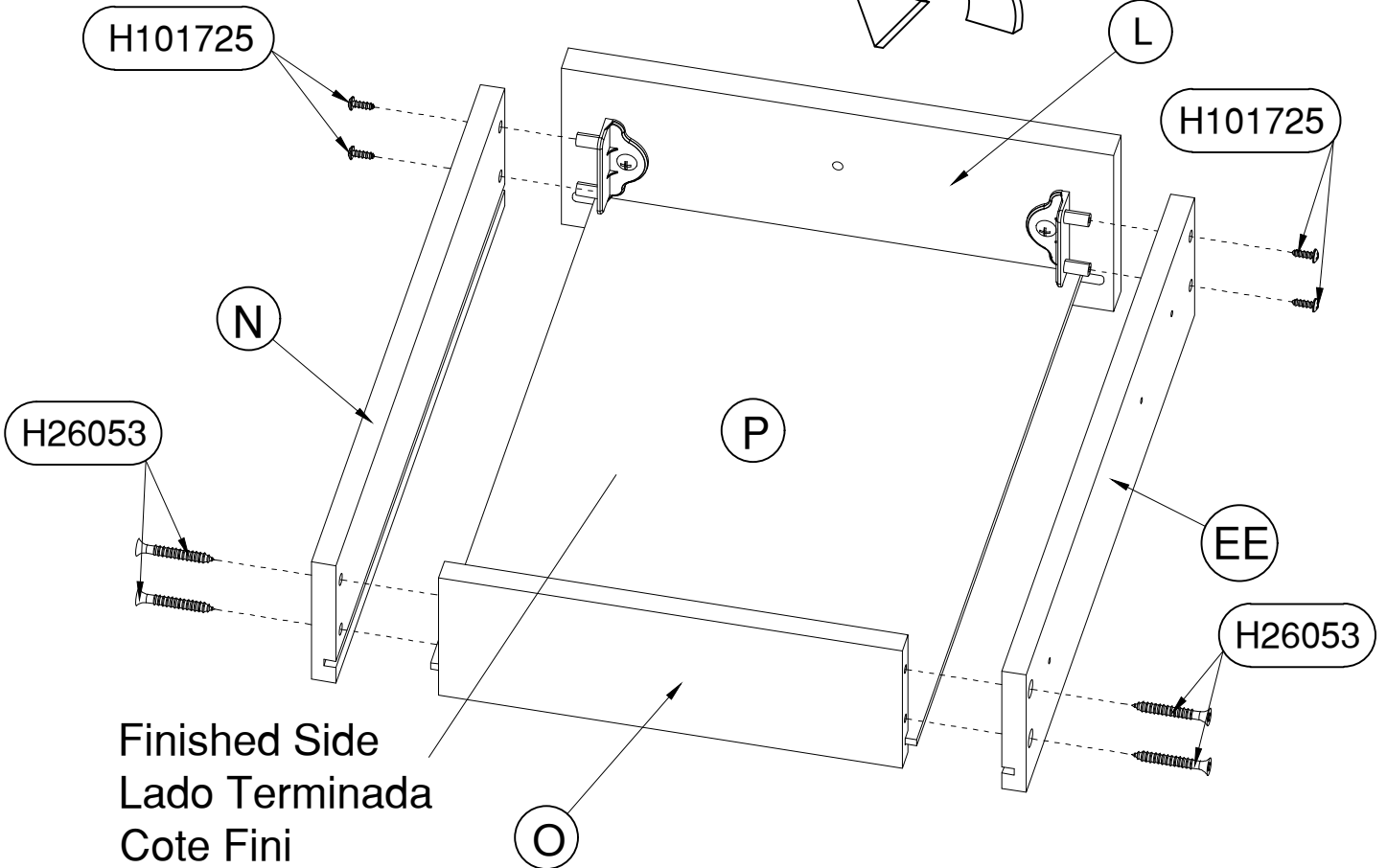
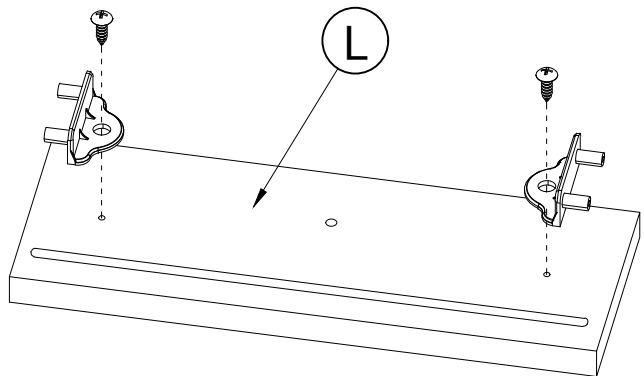
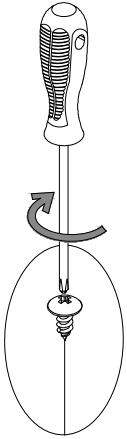

Finished Side  
Lado Terminada  
Cote Fini

STEP 22

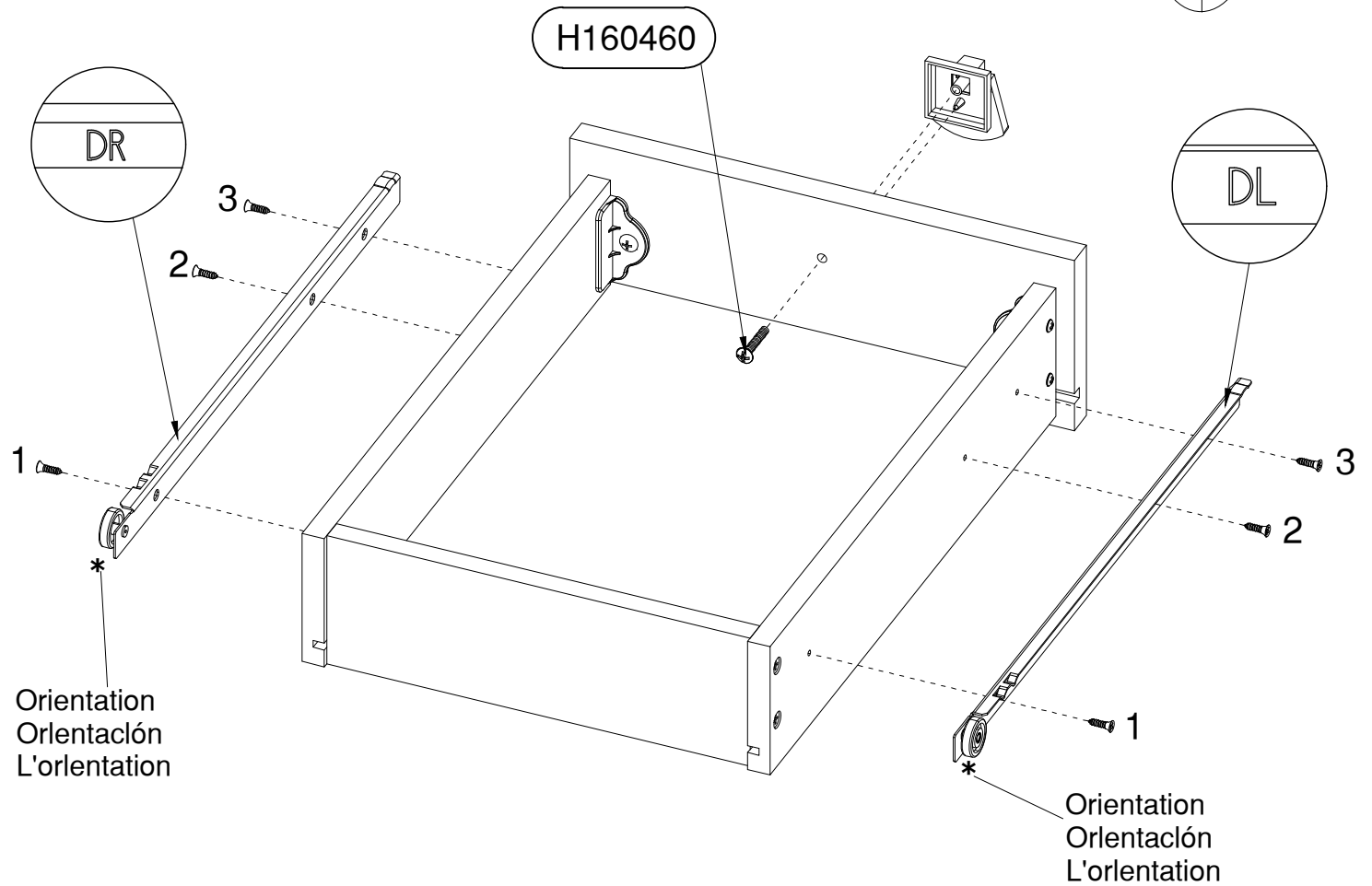
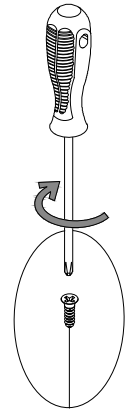
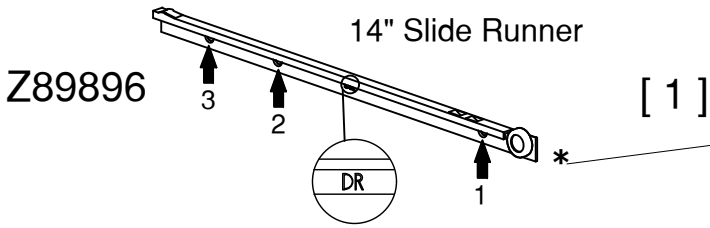
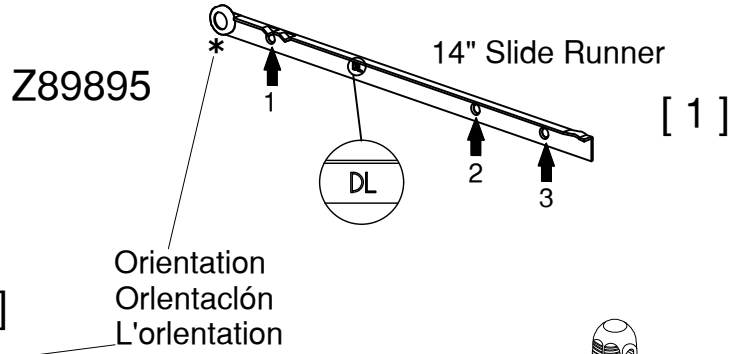
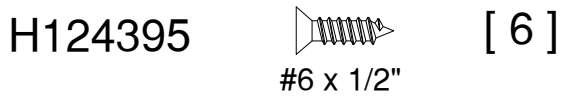
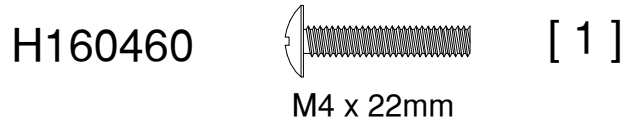
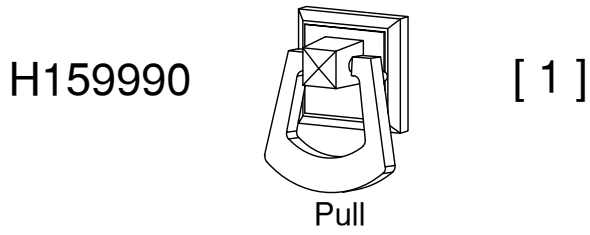

STEP 23

H101725

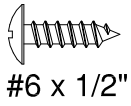

[ 4 ]

Z35216

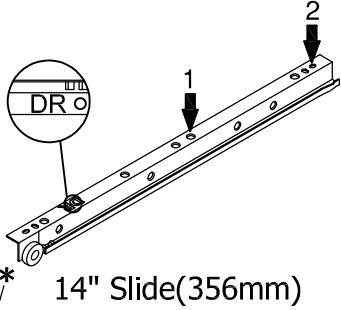

[ 1 ]

Orientation  
Orientación  
L'orientation

Z35217

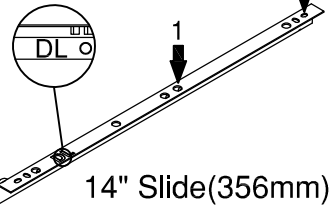

[ 1 ]

Orientation  
Orientación  
L'orientation

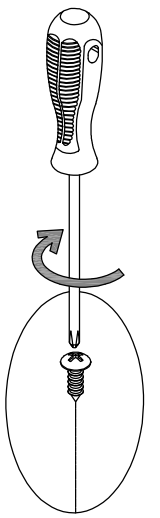

Orientation  
Orientación  
L'orientation

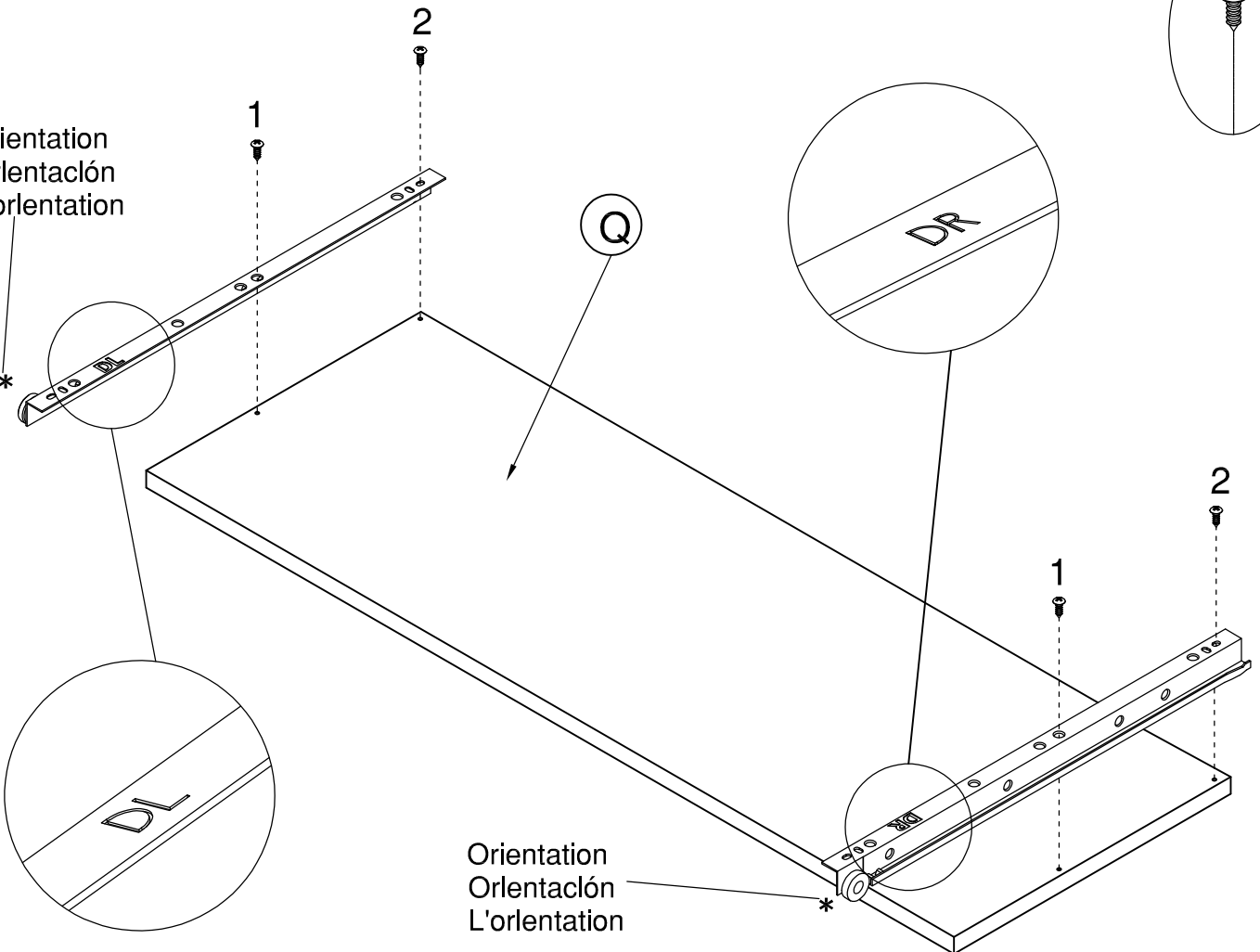

STEP 24

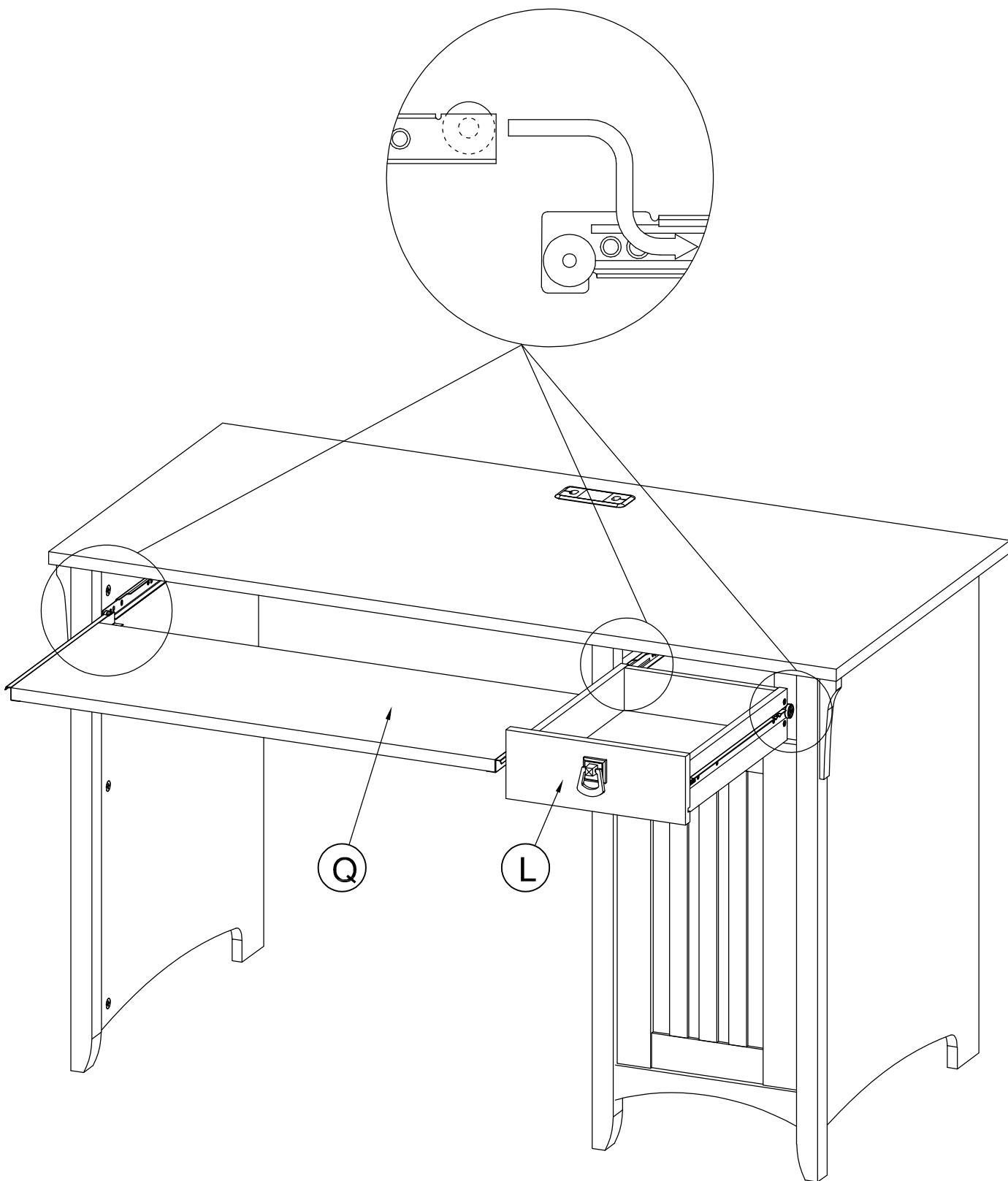

# STEP 25

H180604

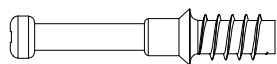

KD Bolt

[ 4 ]

H27145



Glue

H38169



Wood Dowel  
8 x 30mm

[ 2 ]

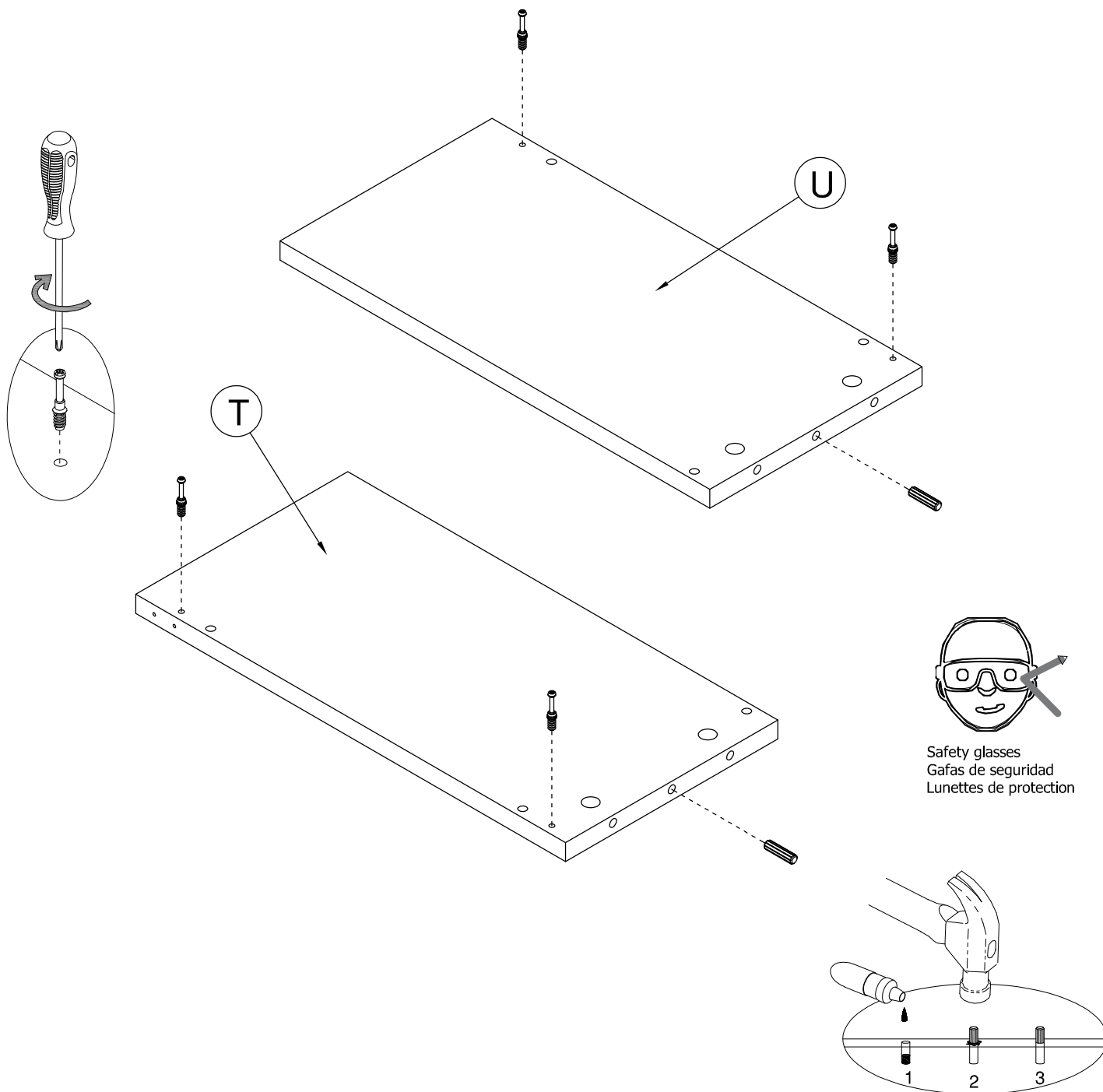

STEP 26

H137197

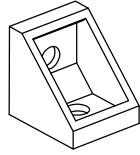

[ 4 ]

Plastic Bracket

H101725

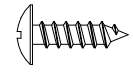

[ 4 ]

#6 x 1/2"

H38169

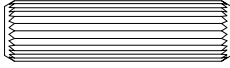

[ 8 ]

Wood Dowel  
8 x 30mm

H27145



Glue

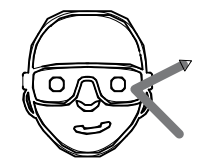
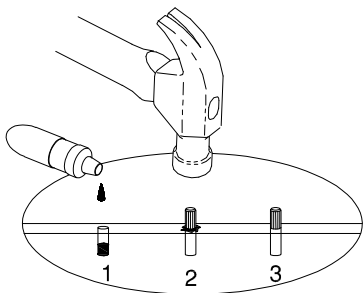
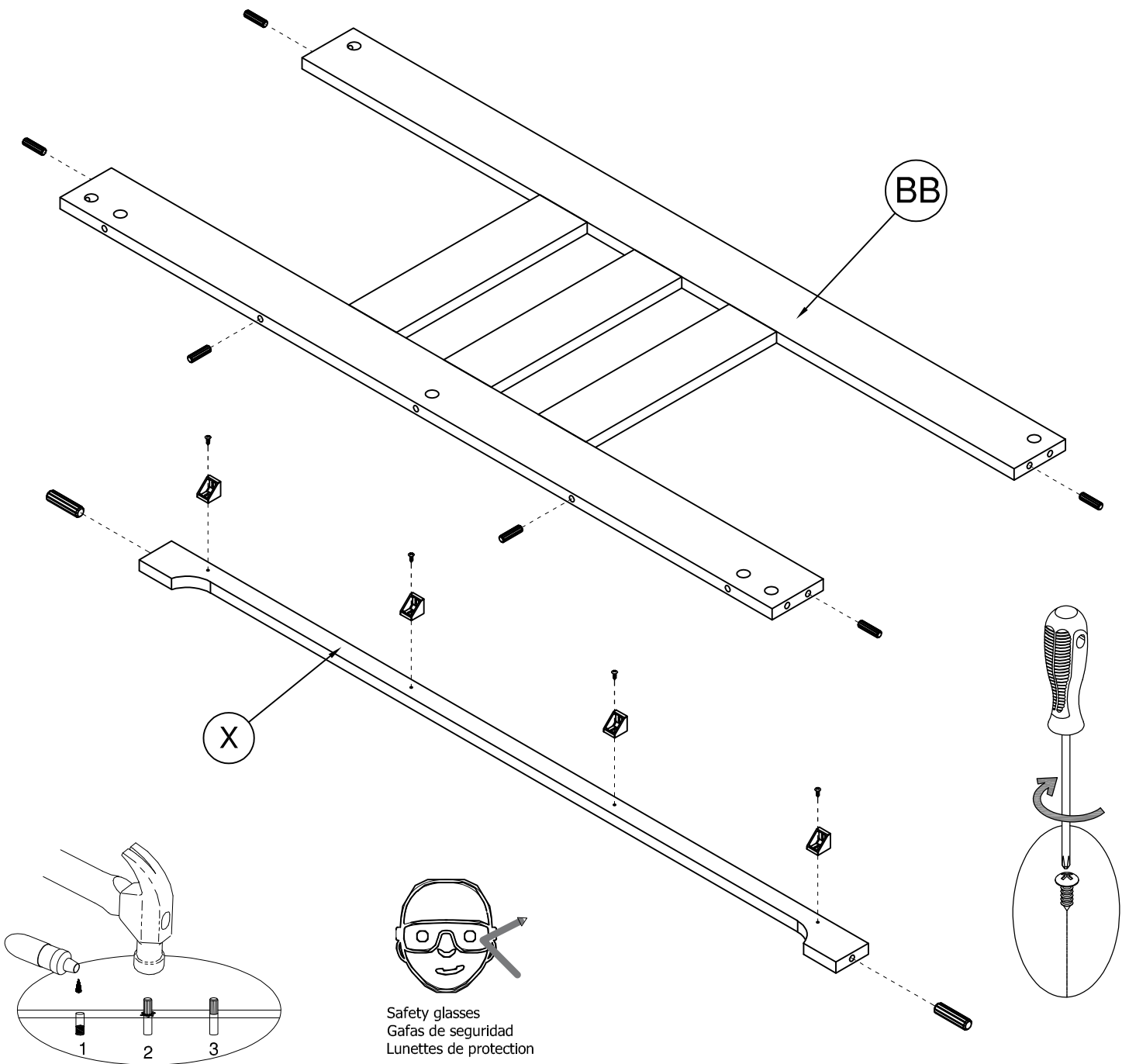

Safety glasses  
Gafas de seguridad  
Lunettes de protection

STEP 27

H181468

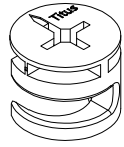

KD Cam

[ 4 ]

H27145



Glue

An assistant is required.  
Es necesario un ayudante.  
Un assistant est nécessaire.

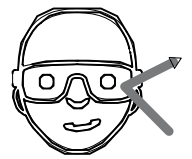
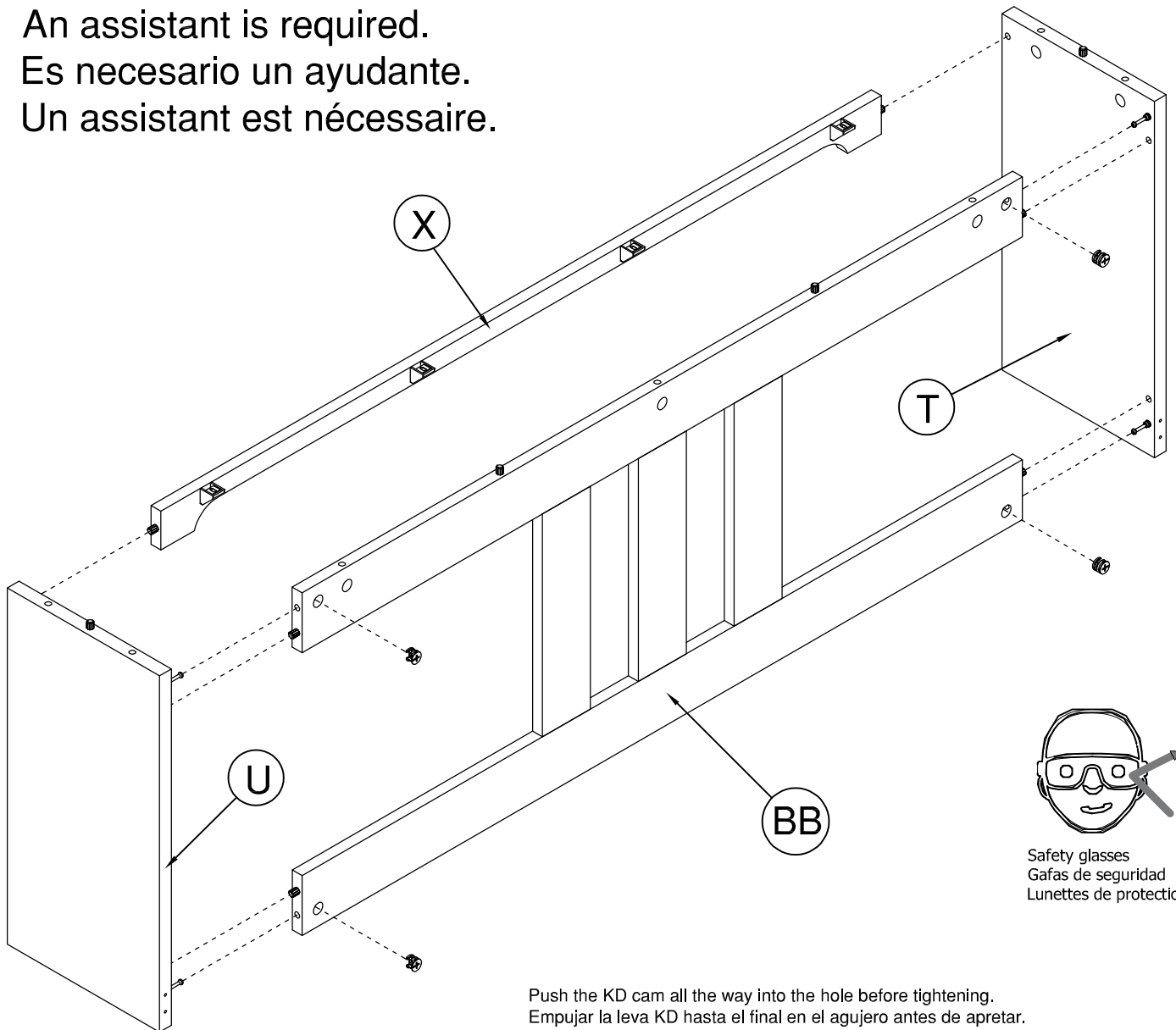

Safety glasses  
Gafas de seguridad  
Lunettes de protection

Push the KD cam all the way into the hole before tightening.  
Empujar la leva KD hasta el final en el agujero antes de apretar.  
Pousser la came de KD tout le chemin dans le trou avant de serrer.

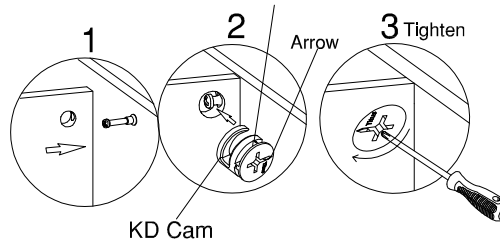

STEP 28

H180604

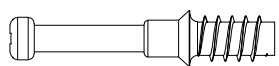

[ 7 ]

KD Bolt

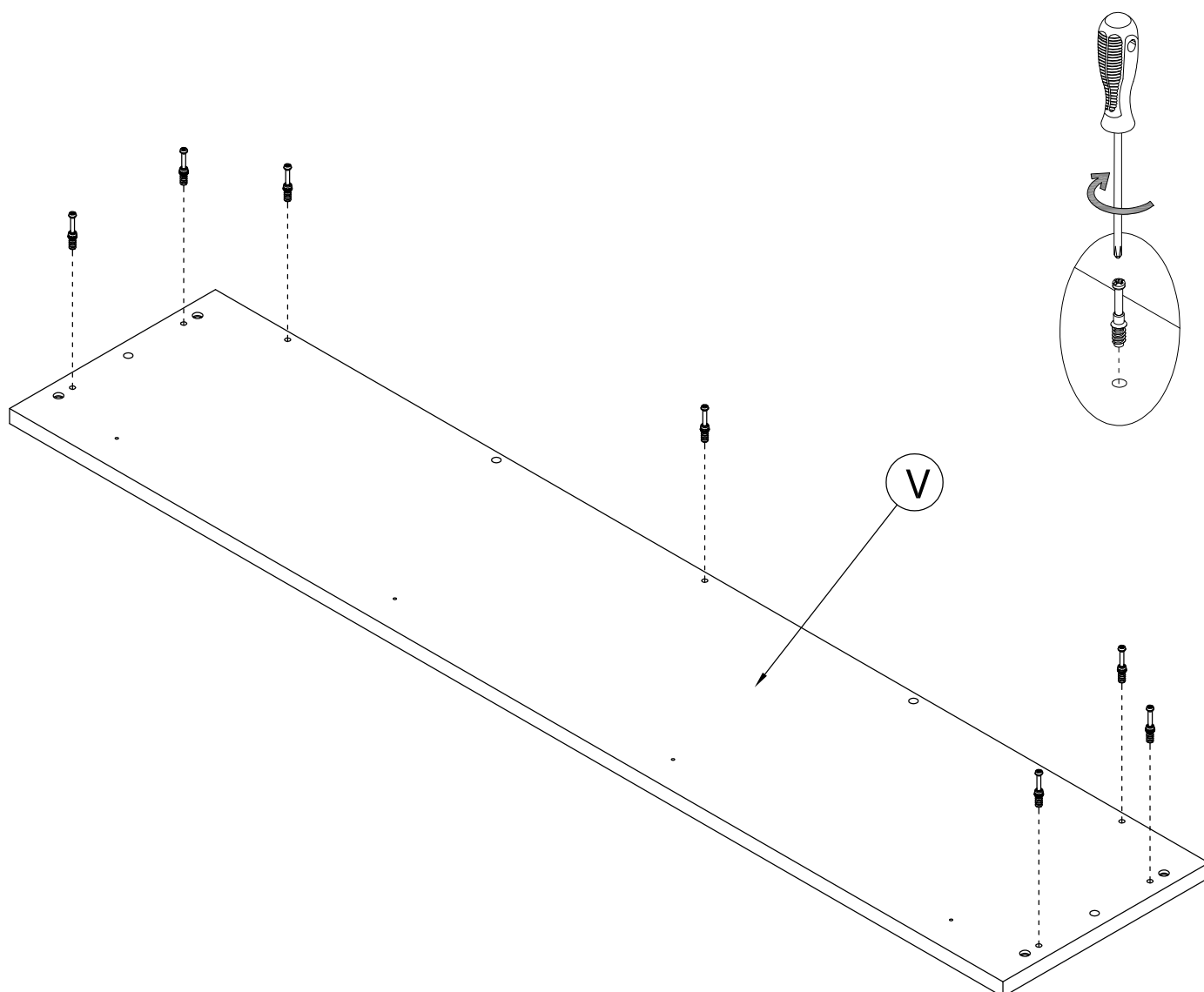

STEP 29

H38169



Wood Dowel  
8 x 30mm

[ 12 ]

H27145

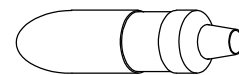

Glue

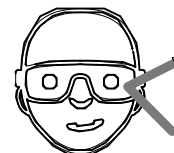

Safety glasses  
Gafas de seguridad  
Lunettes de protection

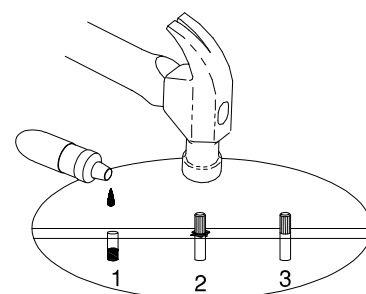
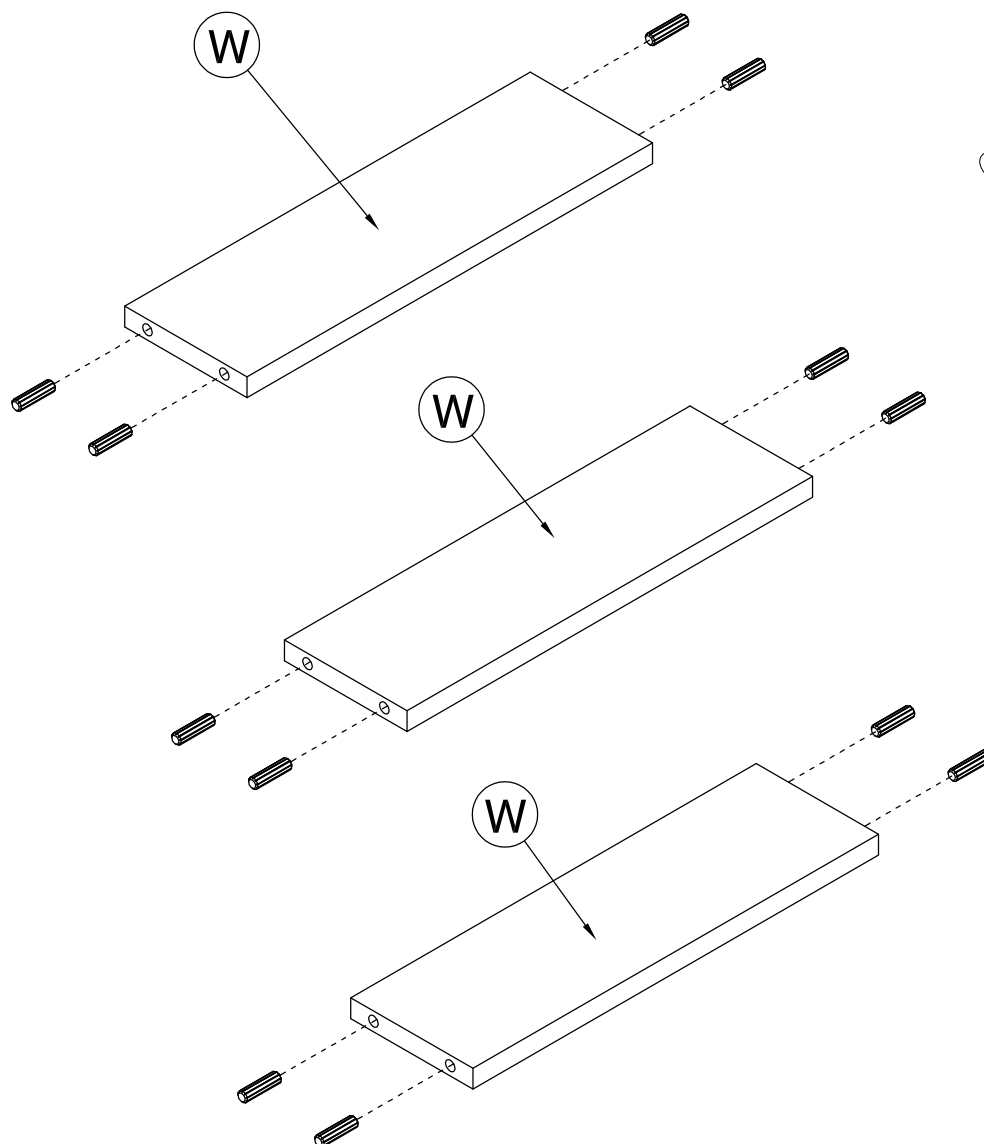

# STEP 30

H38169

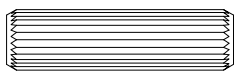

[ 2 ]

Wood Dowel  
8 x 30mm

H27145



Glue

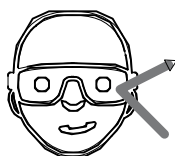
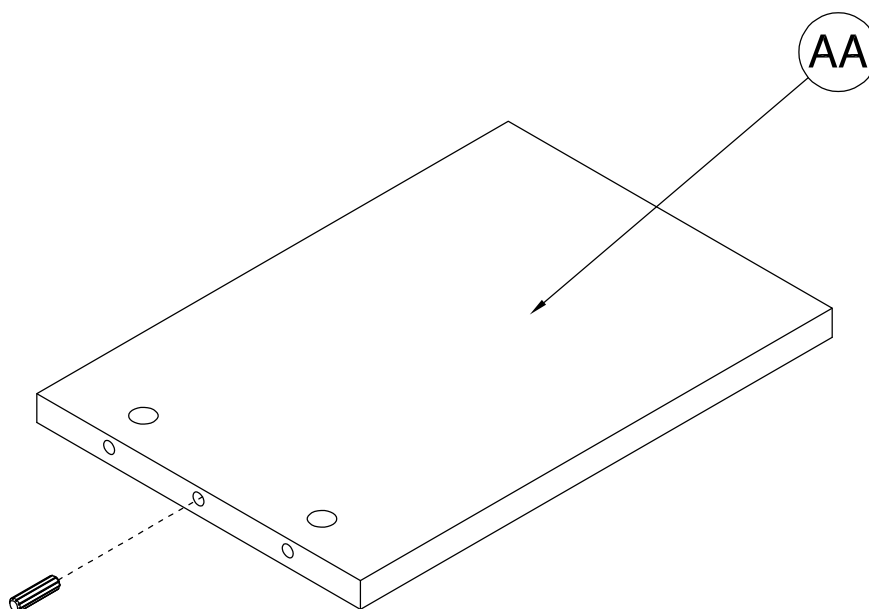
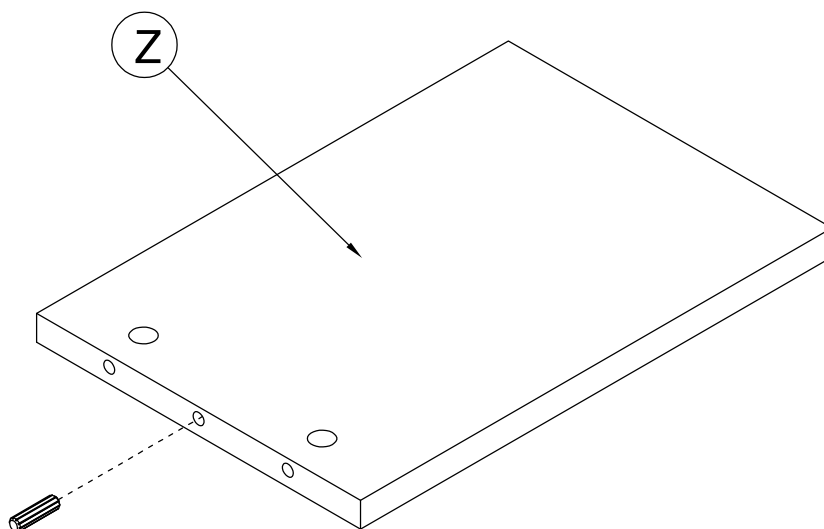

Safety glasses  
Gafas de seguridad  
Lunettes de protection

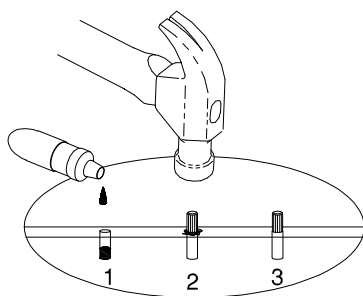

STEP 31

H23491

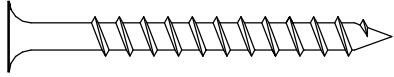

[ 4 ]

#10 x 2"

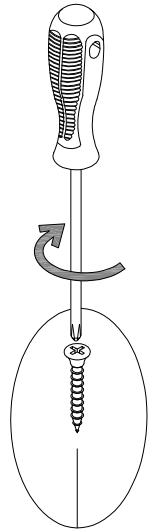

Raw side  
Orilla sin acahado  
Cote Brut

Raw side  
Orilla sin acahado  
Cote Brut

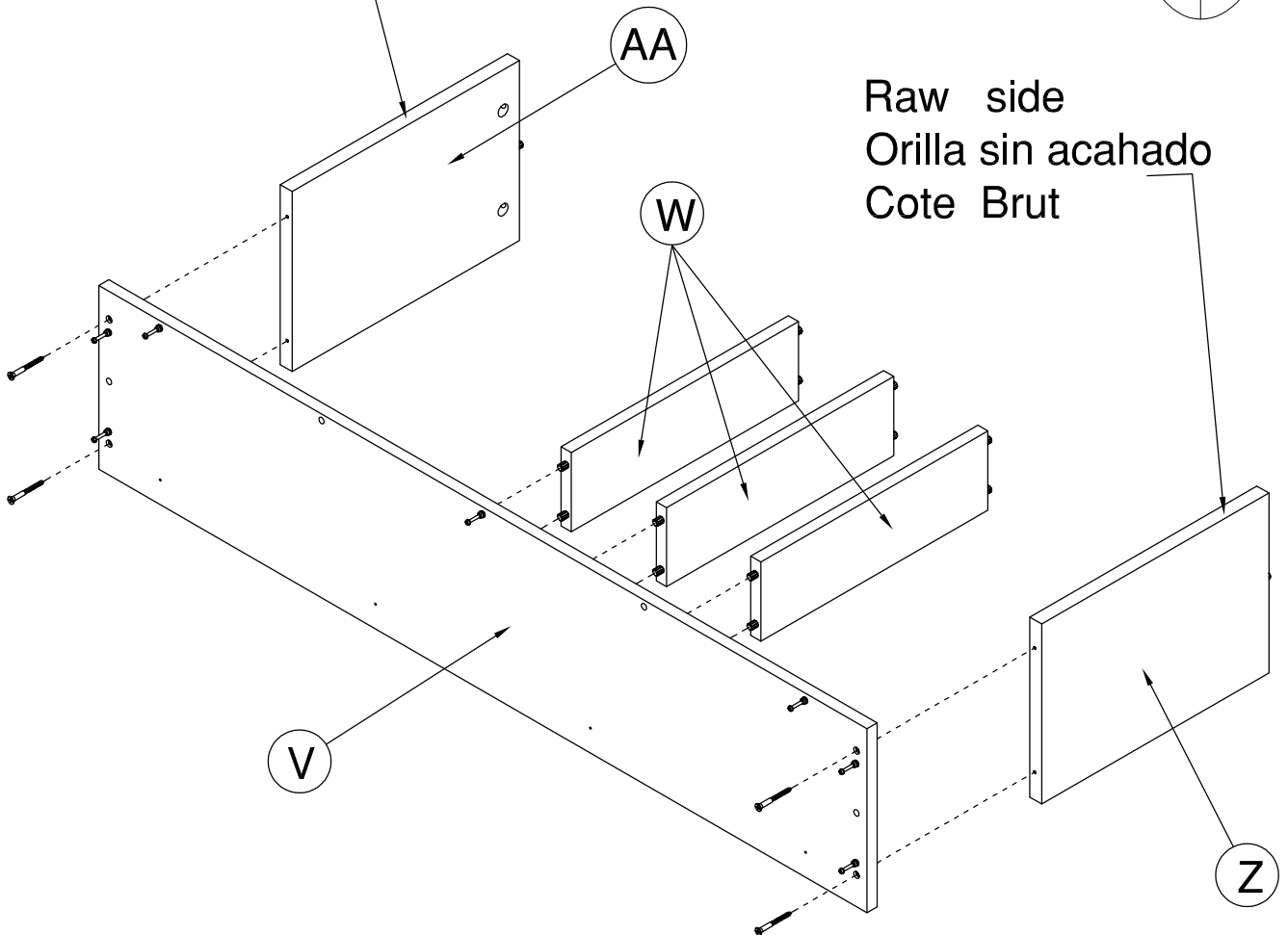

An assistant is required.  
Es necesario un ayudante.  
Un assistant est nécessaire.

STEP 32

H180604

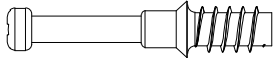

[ 4 ]

KD Bolt

H27771



[ 5 ]

Wood Dowel  
6 x 25mm

H27145

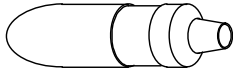

Glue

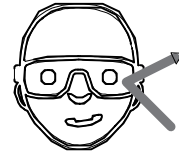

Safety glasses  
Gafas de seguridad  
Lunettes de protection

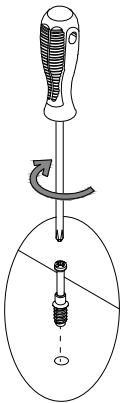
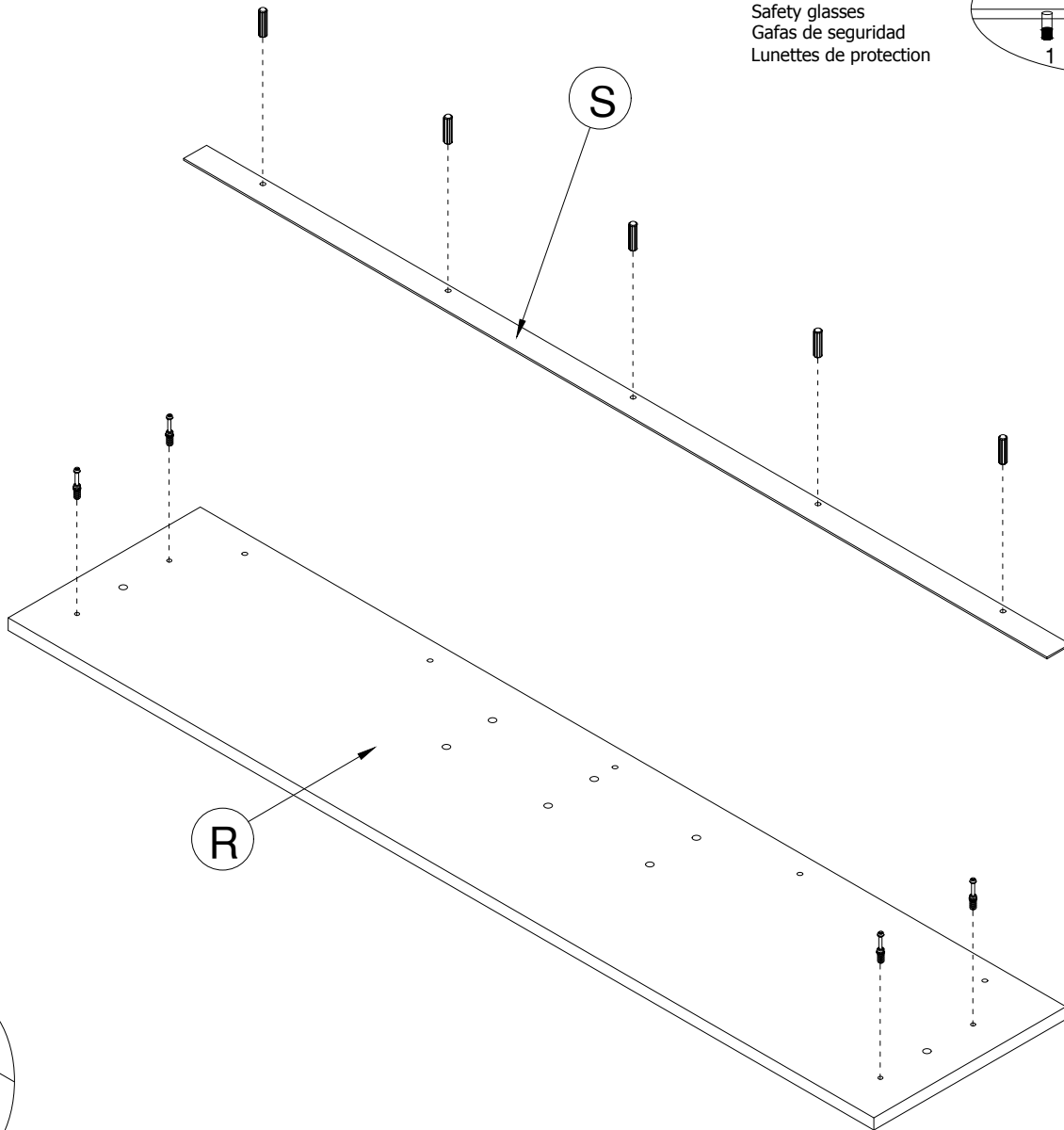
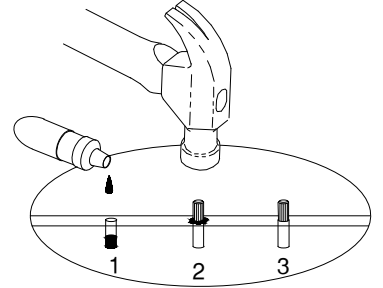

STEP 33

H27145

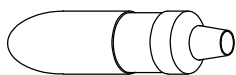

Glue

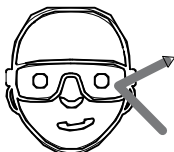

Safety glasses  
Gafas de seguridad  
Lunettes de protection

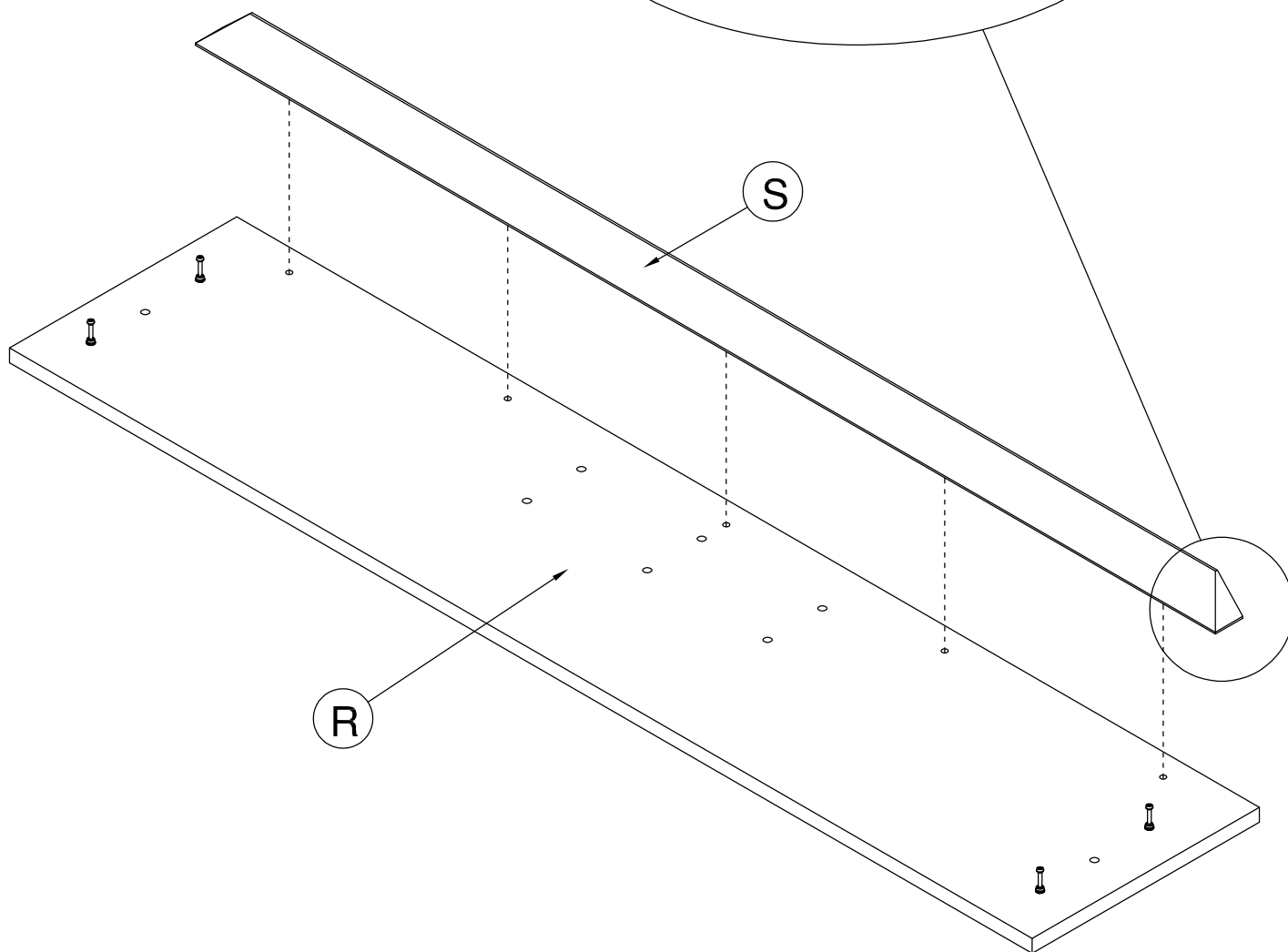
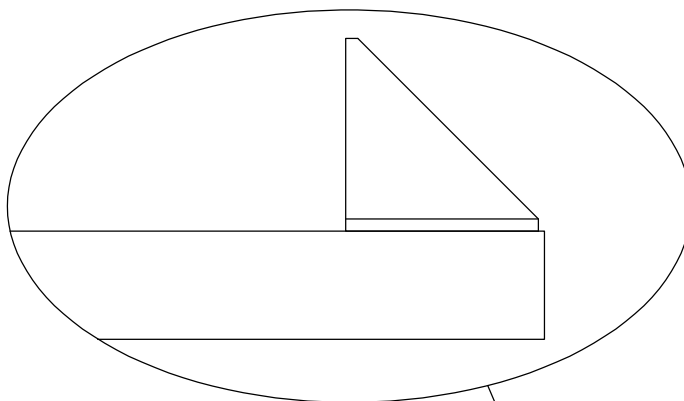

# STEP 34

H160399  
H174677  
H186180

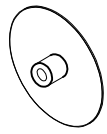

Cover Cap

[ 4 ]

H27145



Glue

H181468

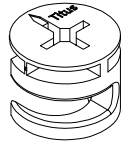

KD Cam

[ 4 ]

Push the KD cam all the way into the hole before tightening.  
Empujar la leva KD hasta el final en el agujero antes de apretar.  
Pousser la came de KD tout le chemin dans le trou avant de serrer.

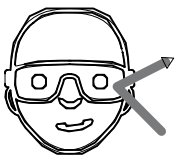
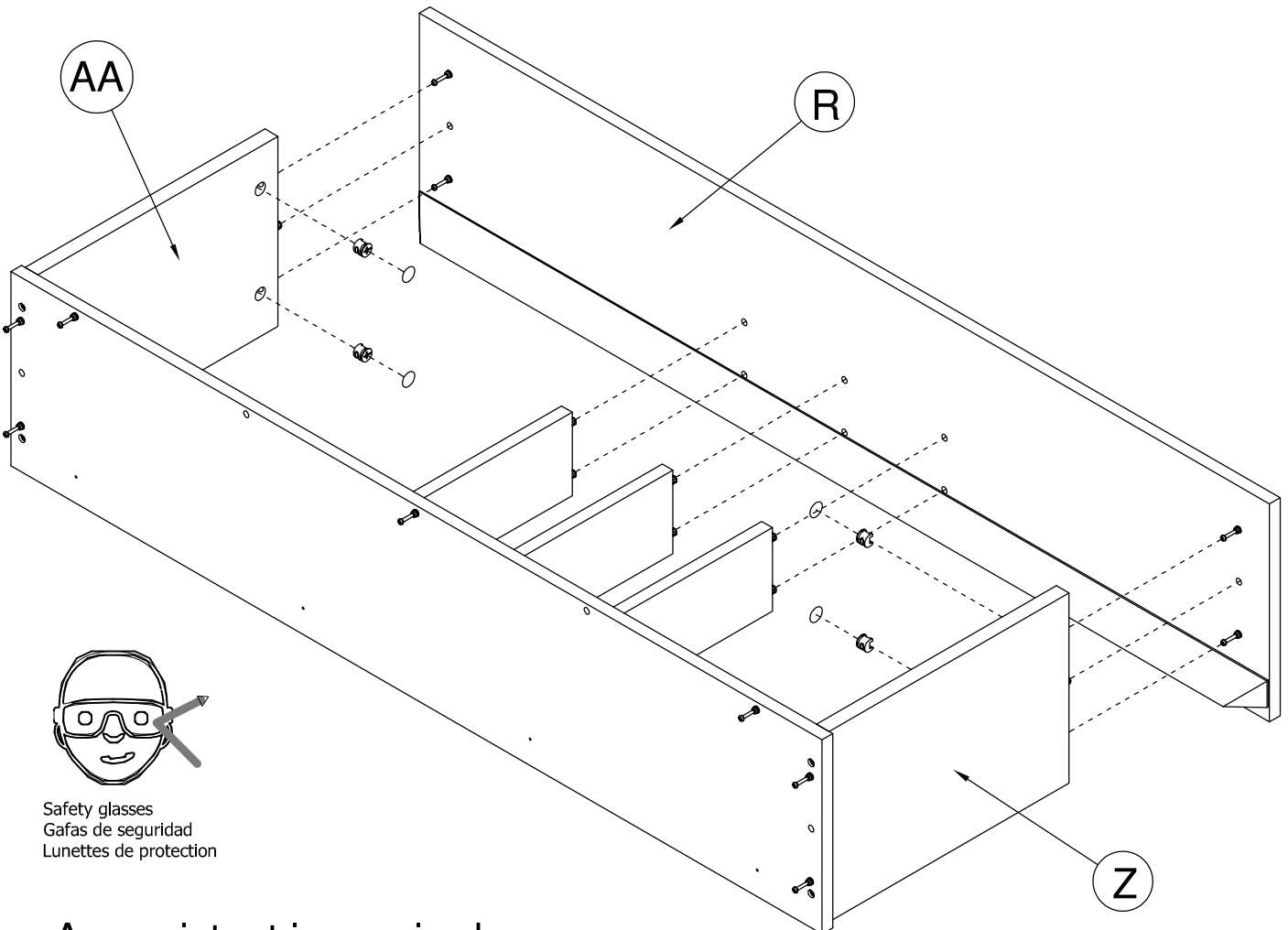
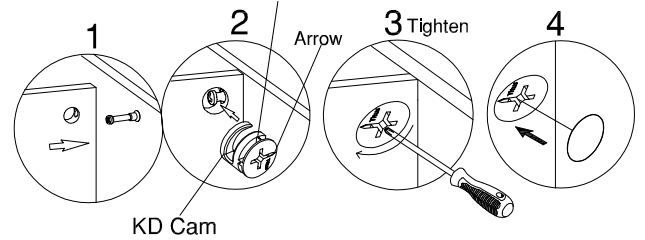

Safety glasses  
Gafas de seguridad  
Lunettes de protection

An assistant is required.  
Es necesario un ayudante.  
Un assistant est nécessaire.

STEP 35

H160399  
H174677  
H186180

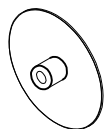

Cover Cap

[ 4 ]

H101725

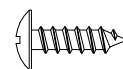

#6 x 1/2"

[ 4 ]

H181468

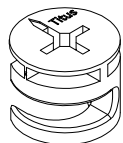

KD Cam

[ 7 ]

H27145



Glue

An assistant is required.  
Es necesario un ayudante.  
Un assistant est nécessaire.

Push the KD cam all the way into the hole before tightening.  
Empujar la leva KD hasta el final en el agujero antes de apretar.  
Pousser la came de KD tout le chemin dans le trou avant de serrer.

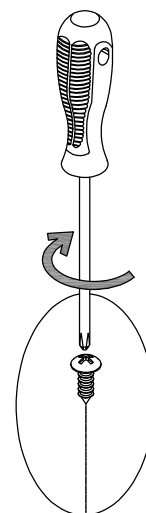
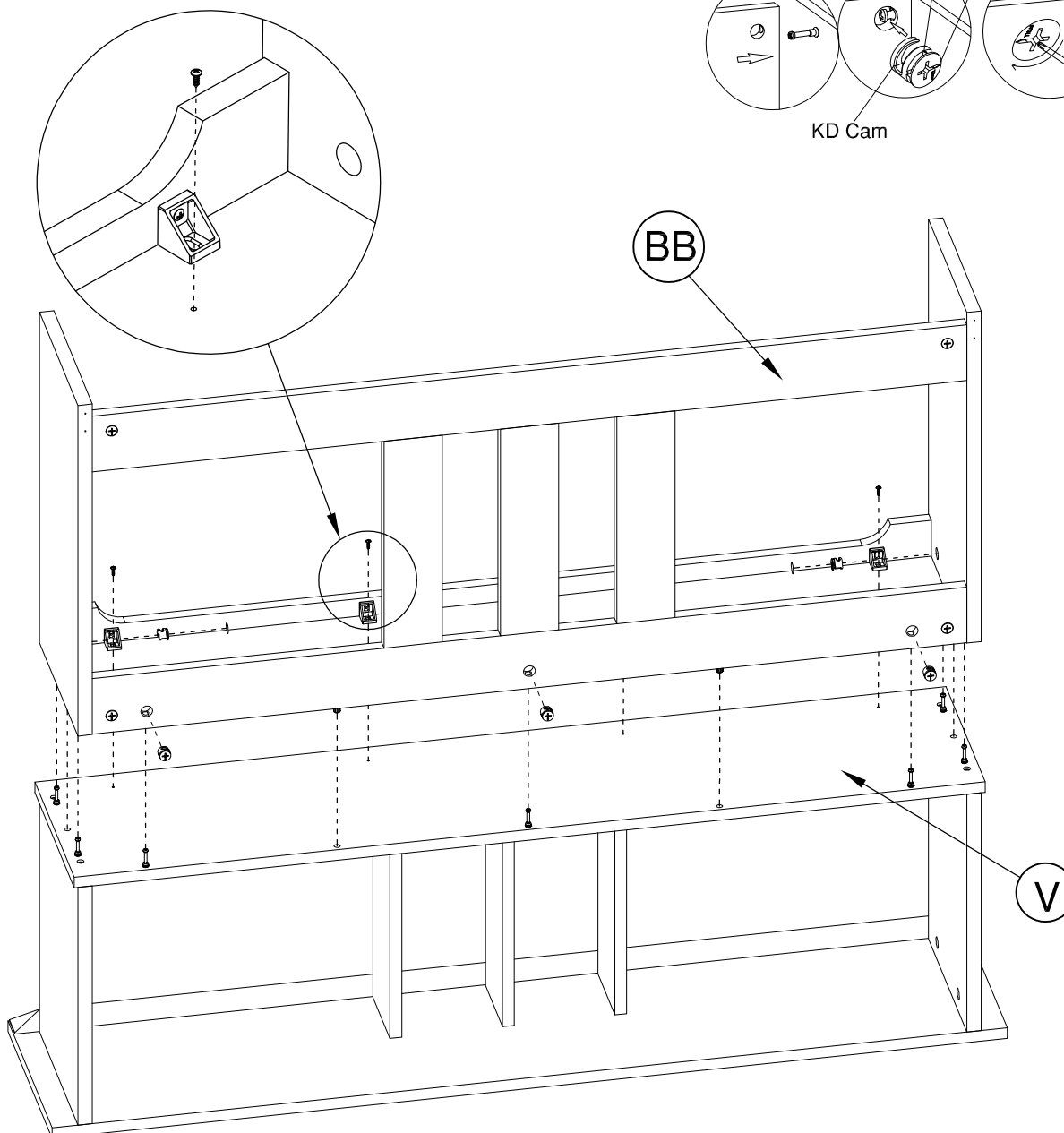
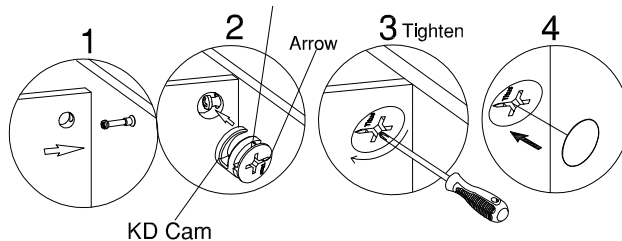

## STEP 36

H34174

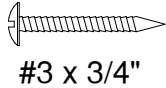

[ 24 ]

#3 x 3/4"

With assistant carefully flip unit over.

Con un asistente cuidadosamente acueste la unidad.

Avec l'aide d'une autre personne, retourner lentement l'unité sur le rebord frontal.

Center the back panel so that the back panel do not stick past the edge of the unit.

Centrez le panneau arrière de manière à ce qu'il ne reste pas au-delà du bord de l'appareil.

Centre el panel posterior de modo que el panel posterior no se pegue más allá del borde de la unidad.

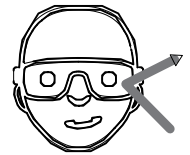
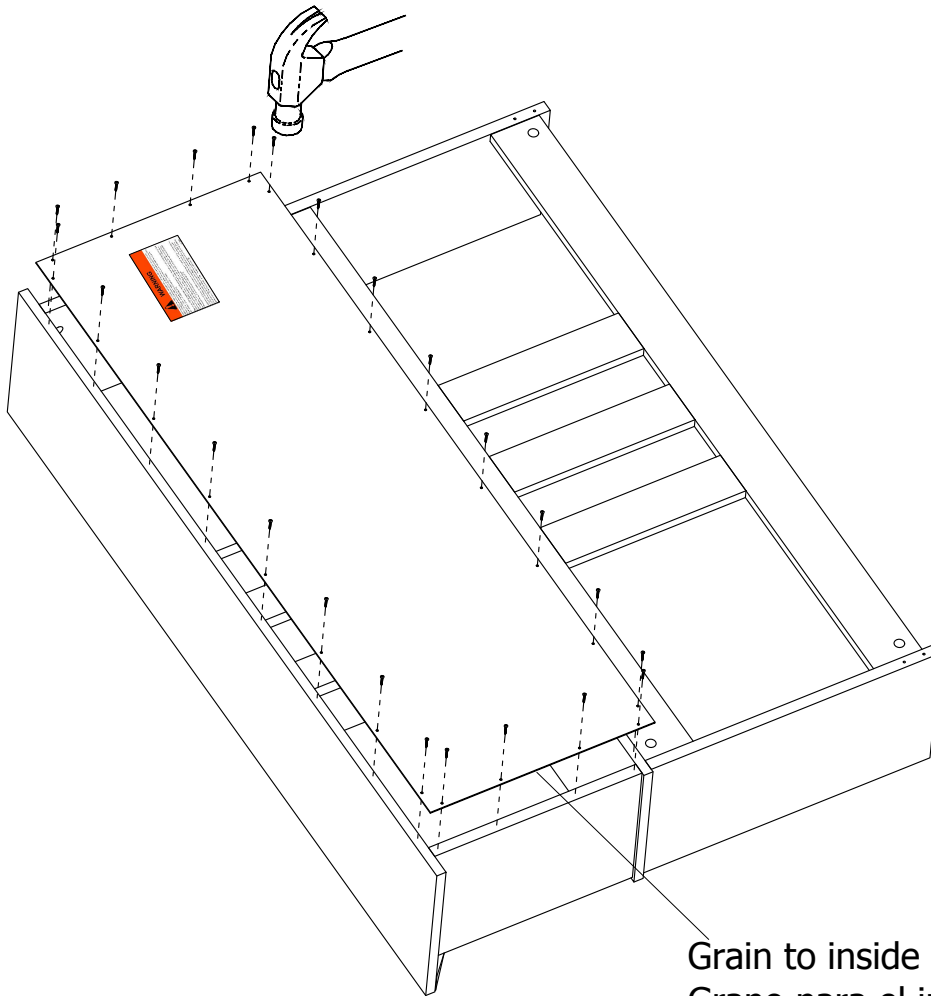

Safety glasses  
Gafas de seguridad  
Lunettes de protection

Grain to inside  
Grano para el interior  
Grain de l'intérieur



### WARNING

Failure to install every indicated nail and/or screw could lead to excessive shelf sagging or product collapse resulting in serious injury or death.

Si no se instalan todos los clavos y / o tornillos indicados, se podría producir un hundimiento excesivo del estante o el colapso del producto, lo que podría provocar lesiones graves o la muerte.

Le fait de ne pas installer chaque clou et / ou vis indiqué pourrait entraîner un affaissement excessif de l'étagère ou un effondrement du produit, entraînant des blessures graves, voire mortelles.

STEP 37

H85966

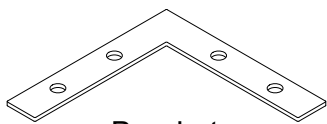

Bracket

[ 2 ]

H150019

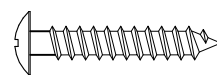

#8 x 1"

[ 8 ]

With assistant carefully stand unit up.

Con un asistente cuidadosamente levante la unidad a una posición vertical.

Avec l'aidé d'un assistant placez soigneusement l'unité debout.

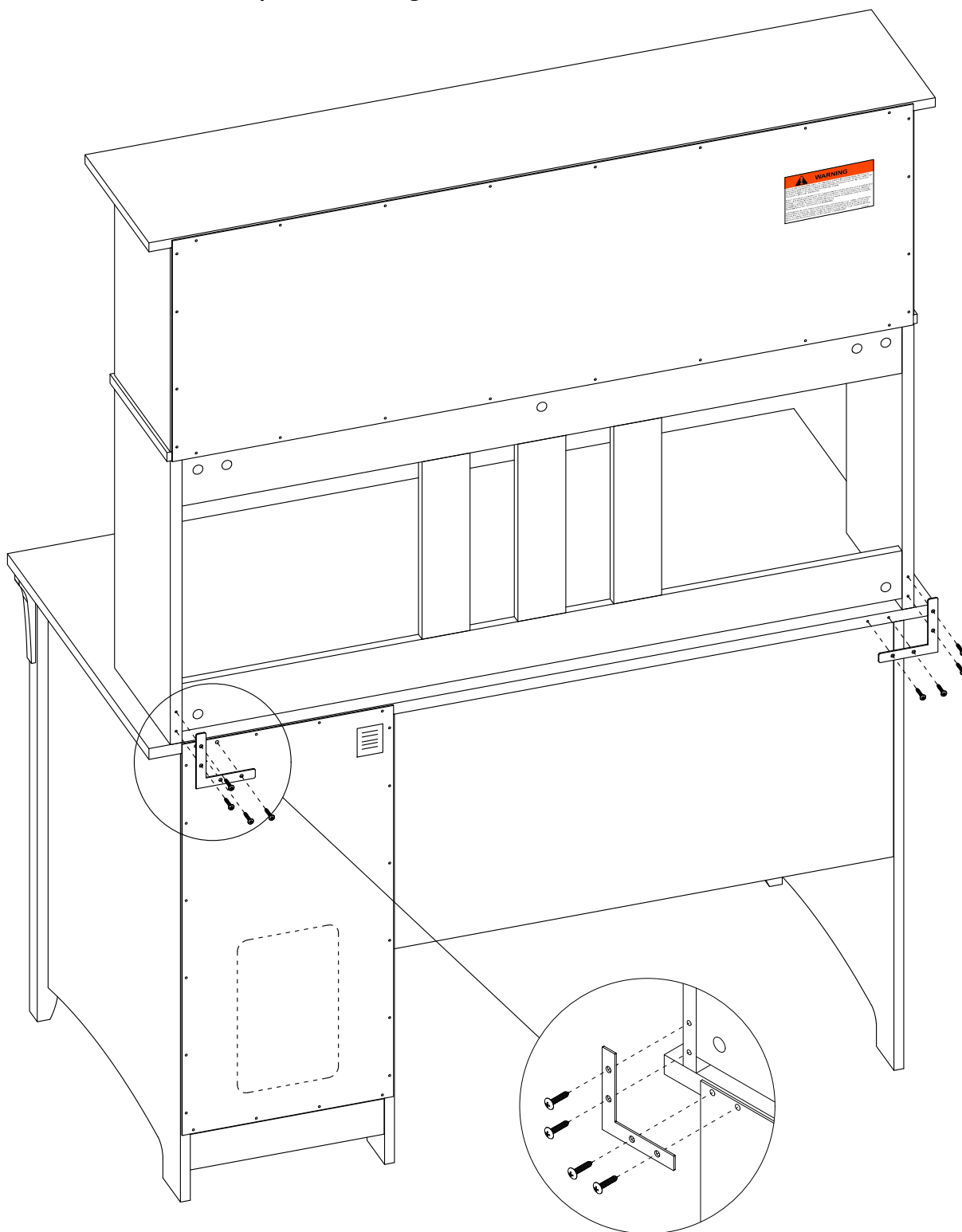
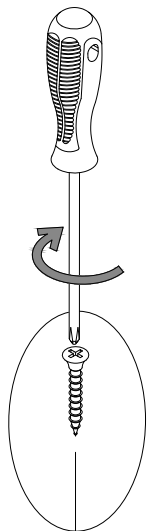

# WARRANTY INFORMATION/INFORMATIONS POUR LA GARANTIE/INFORMACIÓN DE GARANTÍA

## WRITTEN WARRANTY TO YOU

In order to provide you with timely assistance, please thoroughly inspect your furniture for missing or defective parts immediately after opening the carton. To receive replacement or missing parts under this warranty, call our

4782. Please have the Model, Part, and Lot Numbers found in the instruction manual available for your reference. You will also need your sales receipt or other proof of purchase. Replacement part(s) will be shipped to you at no charge with Industries assuming all shipping and handling charges.

This product is warranted to the original purchaser at the time of purchase and for a period of one year thereafter.

We warrant to you, the original purchaser, that our furniture and all its parts and components are free of defects in material or workmanship. "Defects," as used in this warranty, is defined as any imperfection which impairs the use of the furniture product.

Our warranty is expressly limited to the replacement of furniture parts and components. For one year after the date of purchase, will replace any parts that are defective in material or workmanship.

This warranty applies under conditions of normal use. Our products are not intended for outdoor use. This warranty does not cover: 1) defects caused by improper assembly or disassembly; 2) defects occurring after purchase due to product modification, intentional damage, accident, misuse, abuse, negligence or exposure to the elements; and 3) labor or assembly costs.

IMPLIED WARRANTIES, INCLUDING THE WARRANTY OF MERCHANTABILITY, SHALL NOT EXTEND BEYOND THE DURATION OF THE WRITTEN WARRANTY STATED ABOVE, AND IN NO EVENT SHALL BE LIABLE FOR INCIDENTAL OR CONSEQUENTIAL DAMAGES RESULTING FROM USE OF THE PRODUCT. Some states do not allow a limitation on how long an implied warranty lasts or the exclusion or limitation of incidental or consequential damages, so the above limitation and exclusion may not apply to you.

This warranty gives you specific legal rights. You may also have other rights that may vary from state to state.

## VOTRE GARANTIE

Afin de vous assister rapidement, veuillez inspecter votre mobilier en détail immédiatement après l'ouverture du carton en cas de pièces manquantes ou défectueuses. Pour recevoir une pièce de rechange ou manquante couverte par cette garantie, appelez notre département de service clientèle GRATUITEMENT au

. Veuillez tenir à disposition les numéros de modèle, de pièce et de lot qui se trouvent dans le manuel d'instruction pour votre référence. Vous aurez également besoin de votre reçu ou d'une autre preuve d'achat. La (les) pièce(s) de rechange vous sera (seront) envoyée(s) sans frais, Industries se chargeant de tous les frais d'expédition.

Tout le produit est garanti à l'acheteur original à partir de la date d'achat pour une période d'un an.

Nous vous garantissons, à vous l'acheteur original, que notre mobilier et toutes ses pièces et composants sont sans défaut de matériau ou de fabrication. Le terme "défauts" utilisé dans cette garantie, est défini comme étant toutes les imperfections qui compromettent l'utilisation du meuble.

Notre garantie est expressément limitée au remplacement des pièces et des composants du mobilier. Pendant un an après la date d'achat, remplacera toute pièce défectueuse dans le matériau ou sa fabrication.

Cette garantie d'applique sous des conditions d'utilisation normale. Nos produits ne sont pas destinés à être utilisés en plein air. Cette garantie ne couvre pas: 1) les défauts causés par un mauvais assemblage ou démontage, 2) les défauts ayant lieu après l'achat et dus à la modification du produit, des dommages intentionnels, des accidents, une mauvaise utilisation, un mauvais traitement, la négligence ou l'exposition aux éléments, et 3) les frais de main d'œuvre ou d'assemblage.

LES GARANTIES TACITES, Y COMPRIS LA GARANTIE DE QUALITE MARCHANDE, NE S'ETENDRONT PAS AU-DELA DE LA DUREE ECRITE CITEE CI-DESSUS, ET NE SERA EN AUCUN CAS RESPONSABLE DES DOMMAGES ACCESSOIRES OU INDIRECTS RESULTANT DE L'UTILISATION DU PRODUIT. Certains états ne permettent pas d'appliquer une limite à la durée de la garantie tacite, ni une exclusion ou limitation des dommages accessoires ou indirects; dans ce cas les limitations ou exclusion ci-dessus peuvent ne pas s'appliquer à vous.

Cette garantie vous donne des droits légaux spécifiques. Il se peut que vous ayez également d'autres droits qui peuvent varier d'un état à l'autre.

## GARANTIA ESCRITA DE PARA USTED

Para brindarle asistencia oportuna, por favor, verifique detalladamente que a su mueble no le falte o tenga piezas defectuosas inmediatamente después de abrir la caja. Para recibir un reemplazo o la parte faltante bajo esta garantía, llame a nuestro Departamento de Servicio al Consumidor GRATIS al . Sírvase traer los números de modelo, parte y lote que se encuentran en el manual de instrucciones disponible para su referencia. Además, necesitará el recibo de su compra u otra prueba de compra. La(s) pieza(s) de reemplazo le será(n) enviada(s) sin recargo por Industries asumiendo los gastos de envío y manipuleo.

Todo mueble es garantizado al comprador original al momento de la compra y por un periodo de uno año en adelante.

Le garantizamos a usted, el comprador original, que nuestros muebles sus partes y componentes están libres de defectos en materiales o trabajo. "Defectos", según se usa en esta garantía, se define como una imperfección que perjudica el uso del producto mobiliario.

Nuestra garantía se limita expresamente al reemplazo de partes y componentes mobiliarios. Durante uno año después de la fecha de compra, reemplazará cualquier parte defectuosa en material o trabajo.

Esta garantía se aplica bajo condiciones de uso normal. Nuestros productos de no son para uso en exteriores. Esta garantía no cubre: 1) defectos causados por un ensamblaje o desensamblaje inadecuado; 2) defectos que ocurran después de la compra debido a modificación del producto, daño intencional, accidente, mal uso, abuso, negligencia o exposición a los elementos; y 3) costos de trabajo o ensamblaje.

LAS GARANTÍAS IMPLICADAS, INCLUYENDO LA GARANTÍA DE COMERCIABILIDAD, NO SE EXTENDERÁN MÁS ALLÁ DE LA DURACIÓN DE LA GARANTÍA ESCRITA MENCIONADA, Y EN NINGÚN CASO SERÁ RESPONSABLE POR DAÑOS INCIDENTALES O CONSIGUIENTES COMO RESULTADO DEL USO DEL PRODUCTO. Algunos estados no permiten una limitación sobre el tiempo de duración de la garantía implicada o la exclusión o limitación de daños incidentales o consiguientes, de manera que la limitación y exclusión mencionadas pueden no aplicarse para usted.

Esta garantía le otorga derechos legales específicos. Puede también tener otros derechos que pueden variar según los estados.