

RHF SERIES

ASSEMBLY & INSTRUCTION

- **Twin/XL**(RHF 01/02.....)

[CLICK HERE](#)

Size: 75"L×39"W/ 80"L×39"W

- **Full**(RHF 03)

[CLICK HERE](#)

Size: 75"L×54"W

- **Queen**(RHF 04)

[CLICK HERE](#)

Size: 80"L×60"W

- **King/CK**(RHF05/06.....)

[CLICK HERE](#)

Size: 80"L×76"W/84"L×72"W







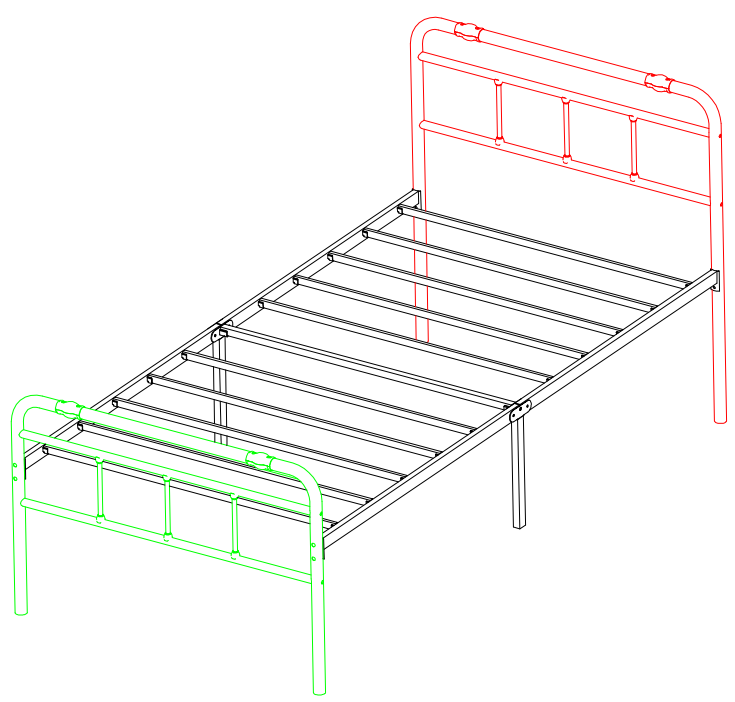



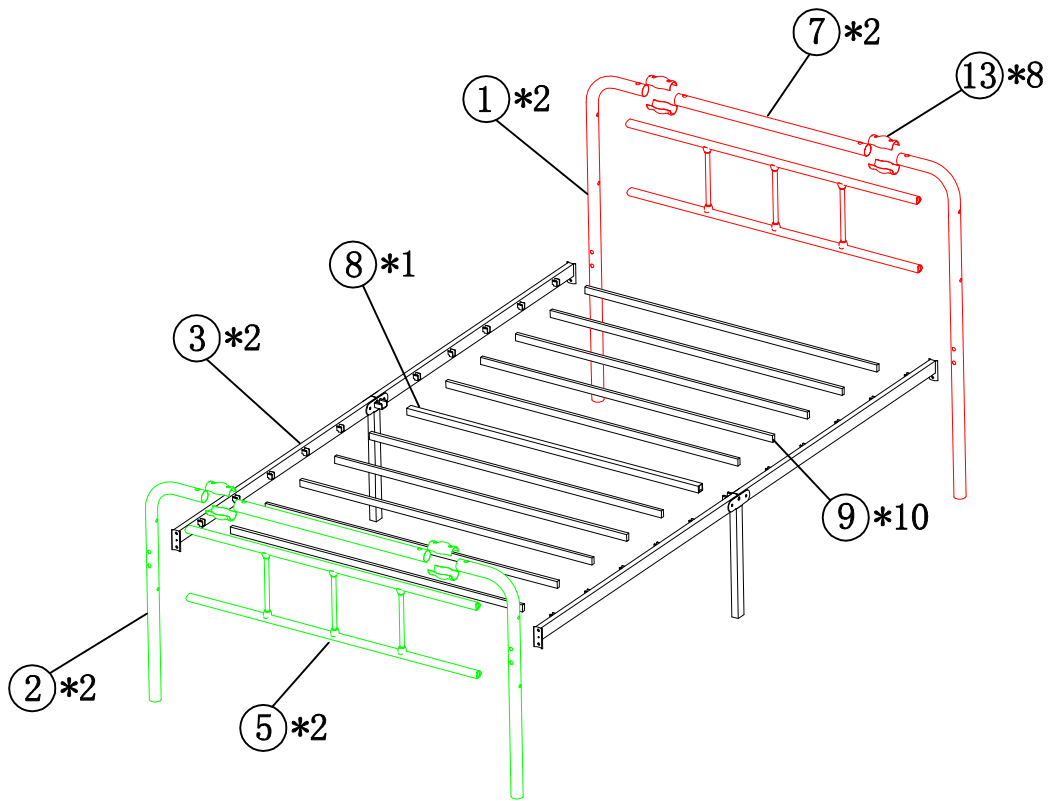

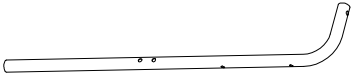

ASSEMBLY INSTRUCTION

If you have any questions about the product, please don't hesitate to contact us.

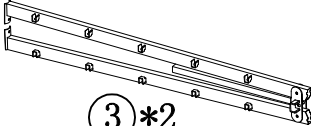
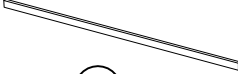

Size: Twin/Twin XL

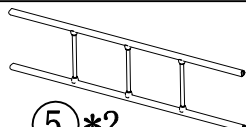



 ①*2	 ⑦*2	 B*8 (M8*50)	 F*2 (M8*35)
 ②*2	 ⑧*1	 C*8 (M6*28)	 K*1
 ③*2	 ⑨*10	 D*8 (M6)	
 ⑤*2	 ⑬*8	 E*8 (M8*40)	

Step1

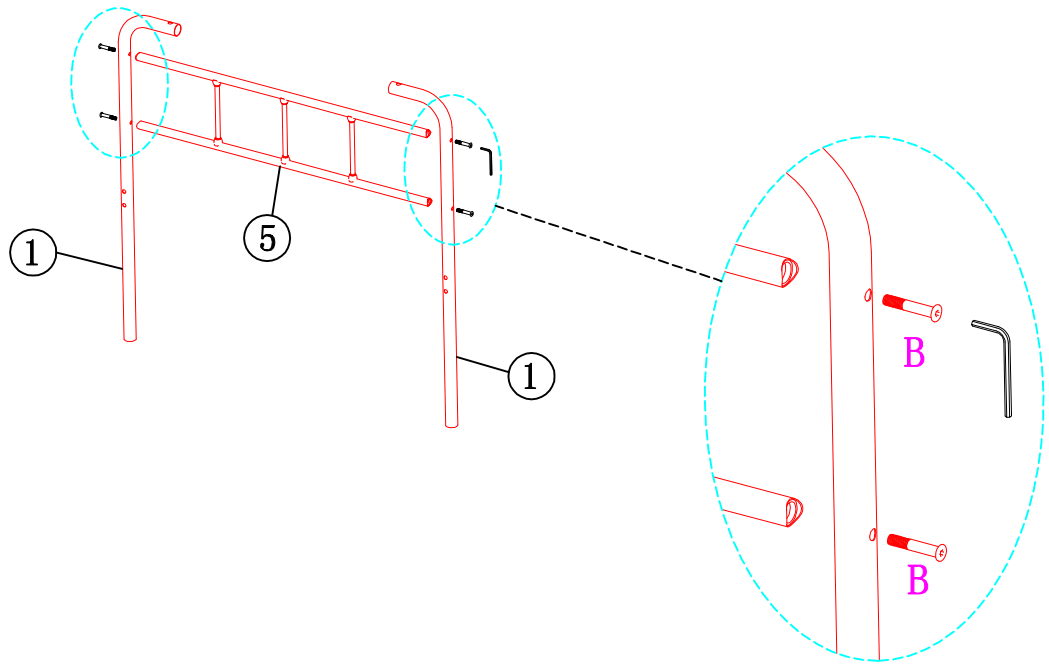
B*4
(M8*50)



Step2

 C*4
(M6*28)  D*4
(M6)

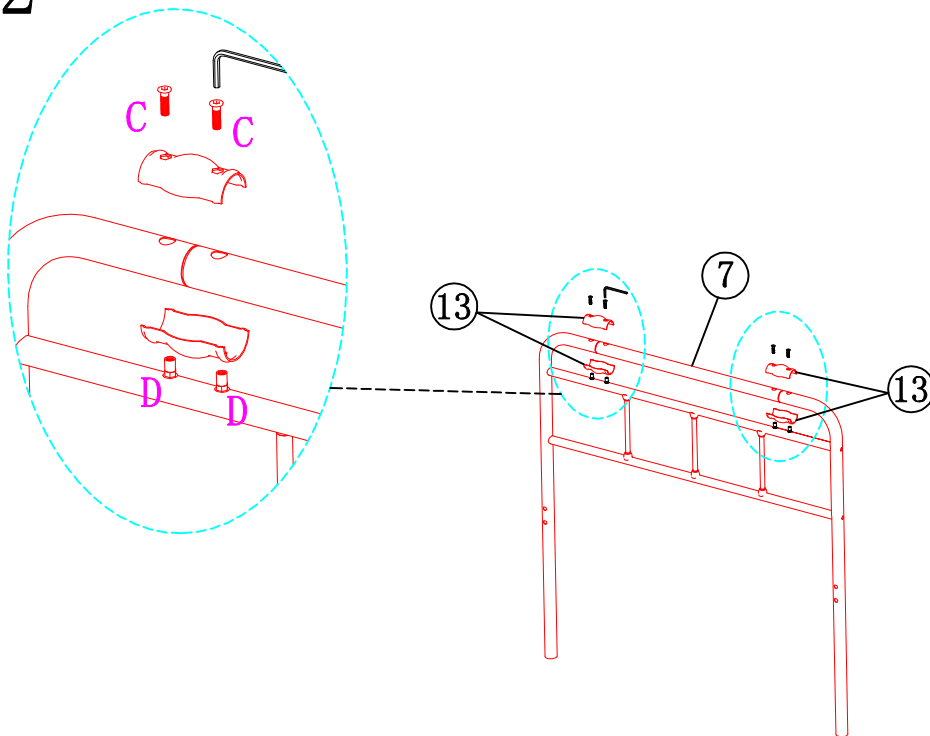

Step3



B*4
(M8*50)

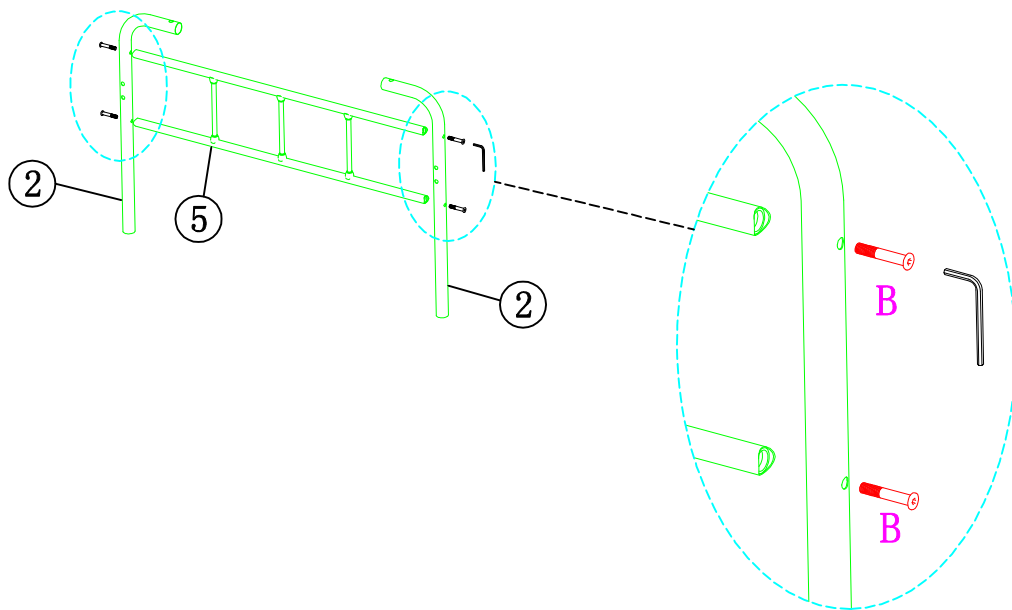

Step4



C*4
(M6*28)



D*4
(M6)

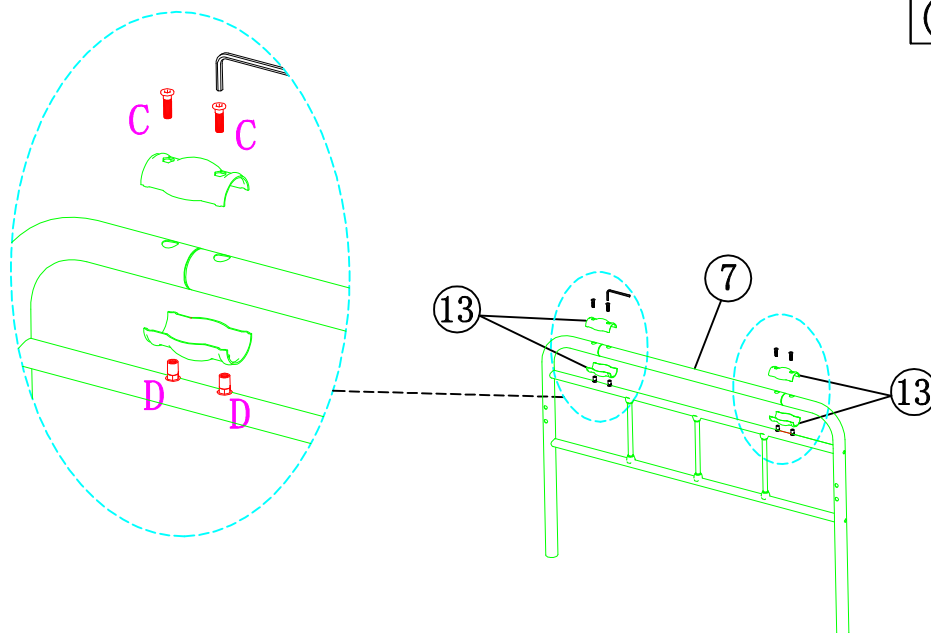

Step5

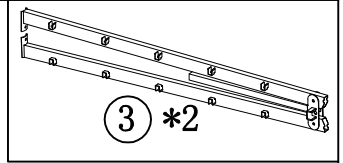

③ *2

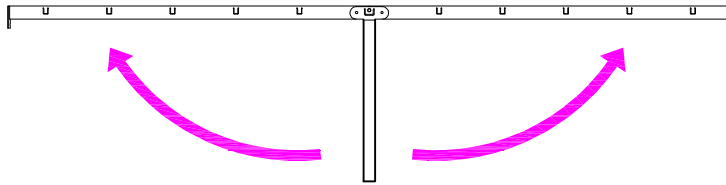
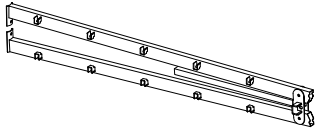

Step6



E*8
(M8*40)

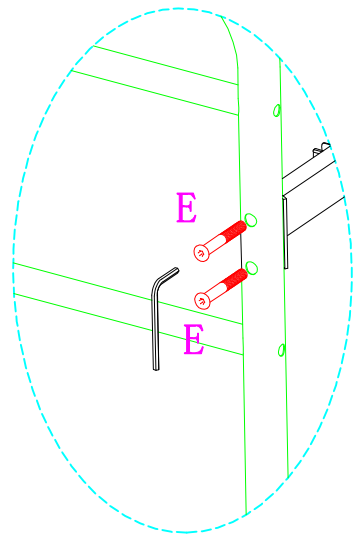
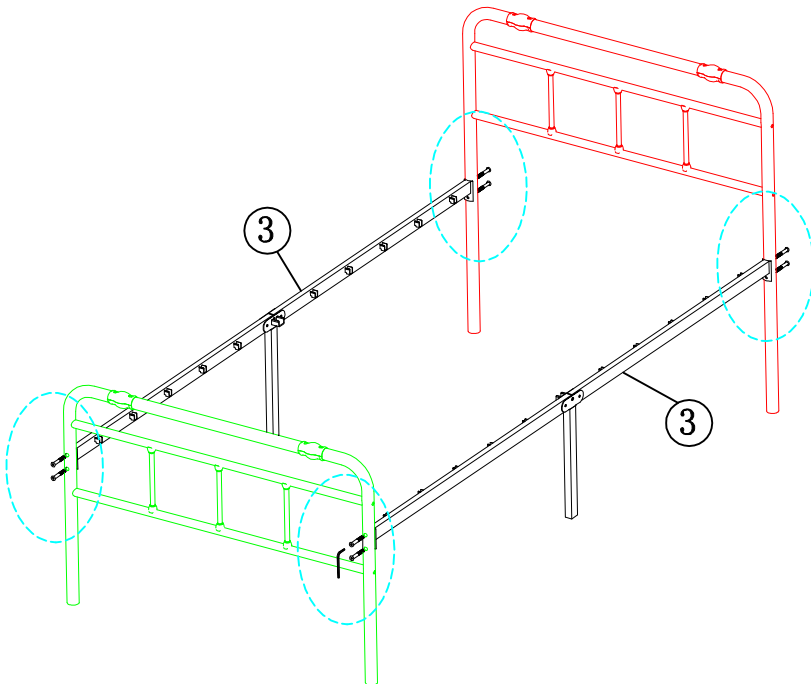

Step7



F*2
(M8*35)

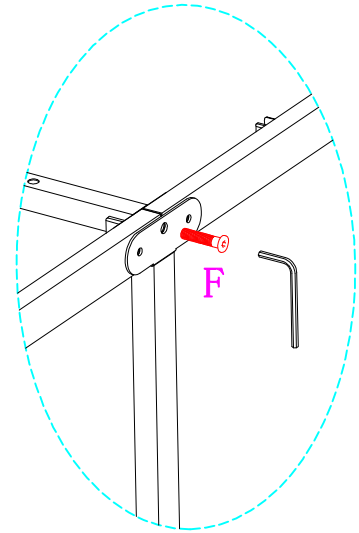
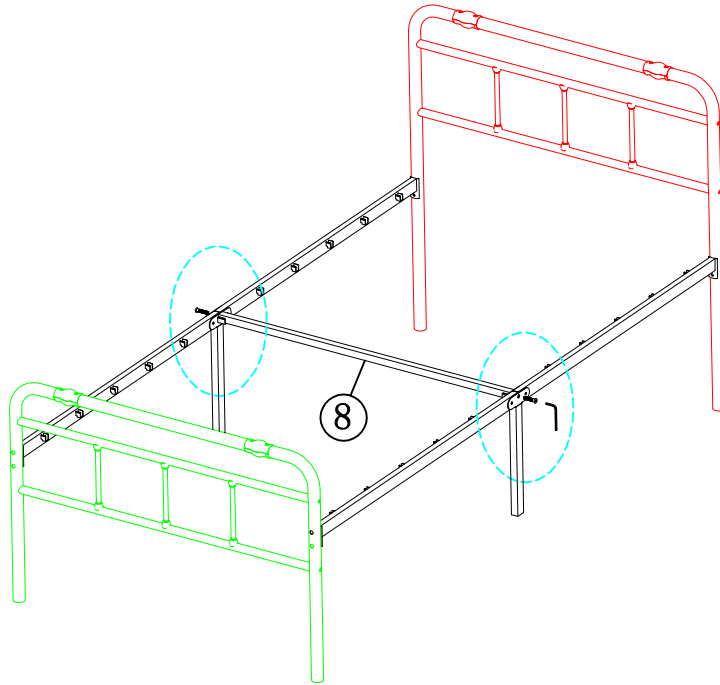

Step8



9*10

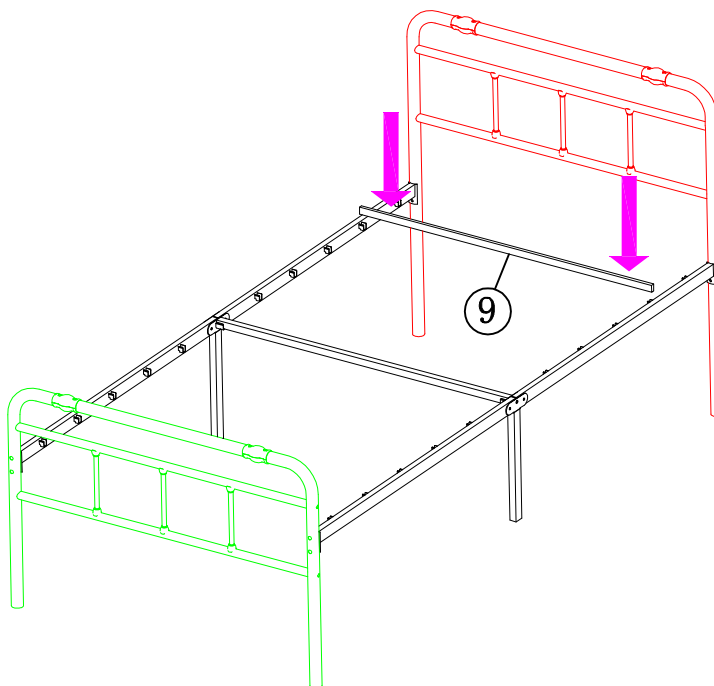

Step9

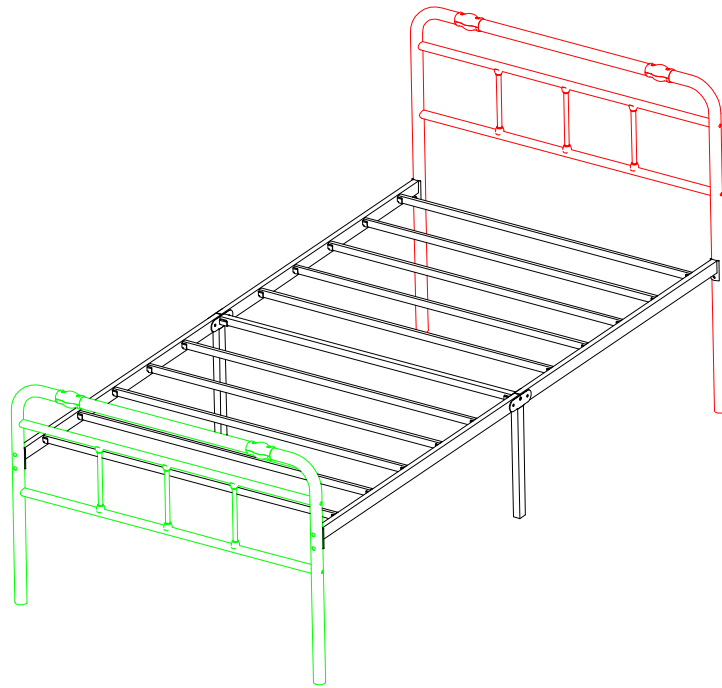

[Back to Top](#)

In the last step. please make sure all the screws are tightened.

ASSEMBLY INSTRUCTION

If you have any questions about the product,
please don't hesitate to contact us.

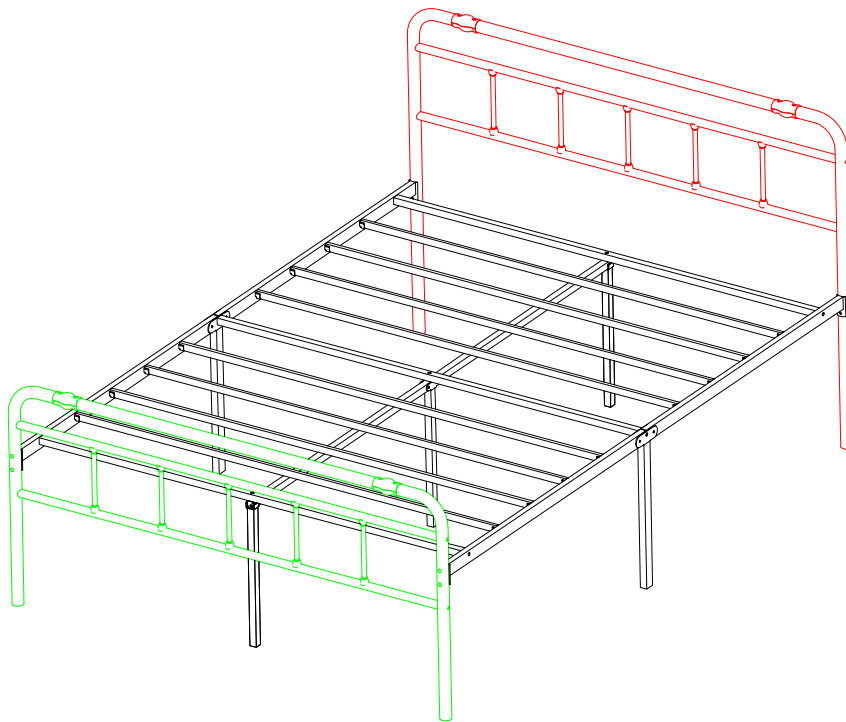

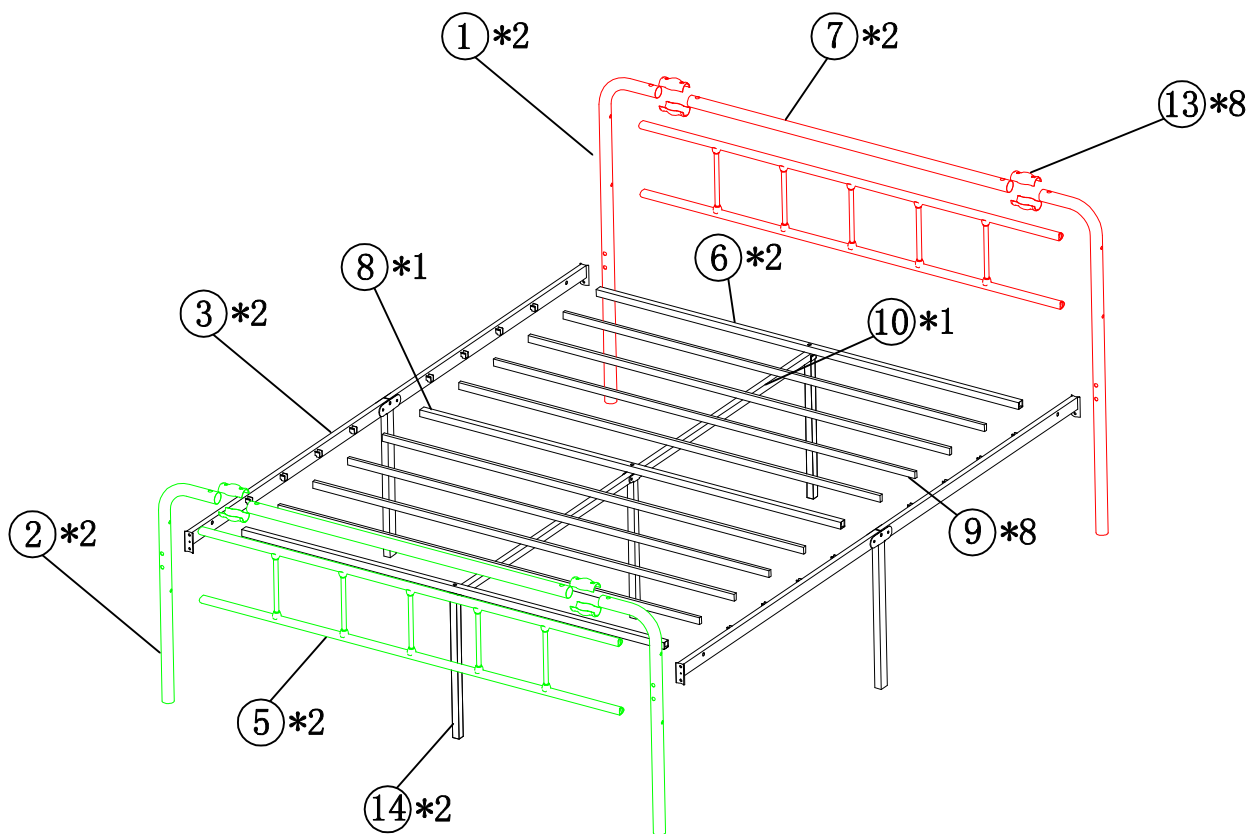

Size: Full





 ①*2	 ⑦*2	 ⑭*2	 F*6 (M8*35)
 ②*2	 ⑧*1	 B*8 (M8*50)	 H*3 (M8*55)
 ③*2	 ⑨*8	 C*8 (M6*28)	 K*1
 ⑤*2	 ⑩*1	 D*8 (M6)	
 ⑥*2	 ⑬*8	 E*8 (M8*40)	

Step1

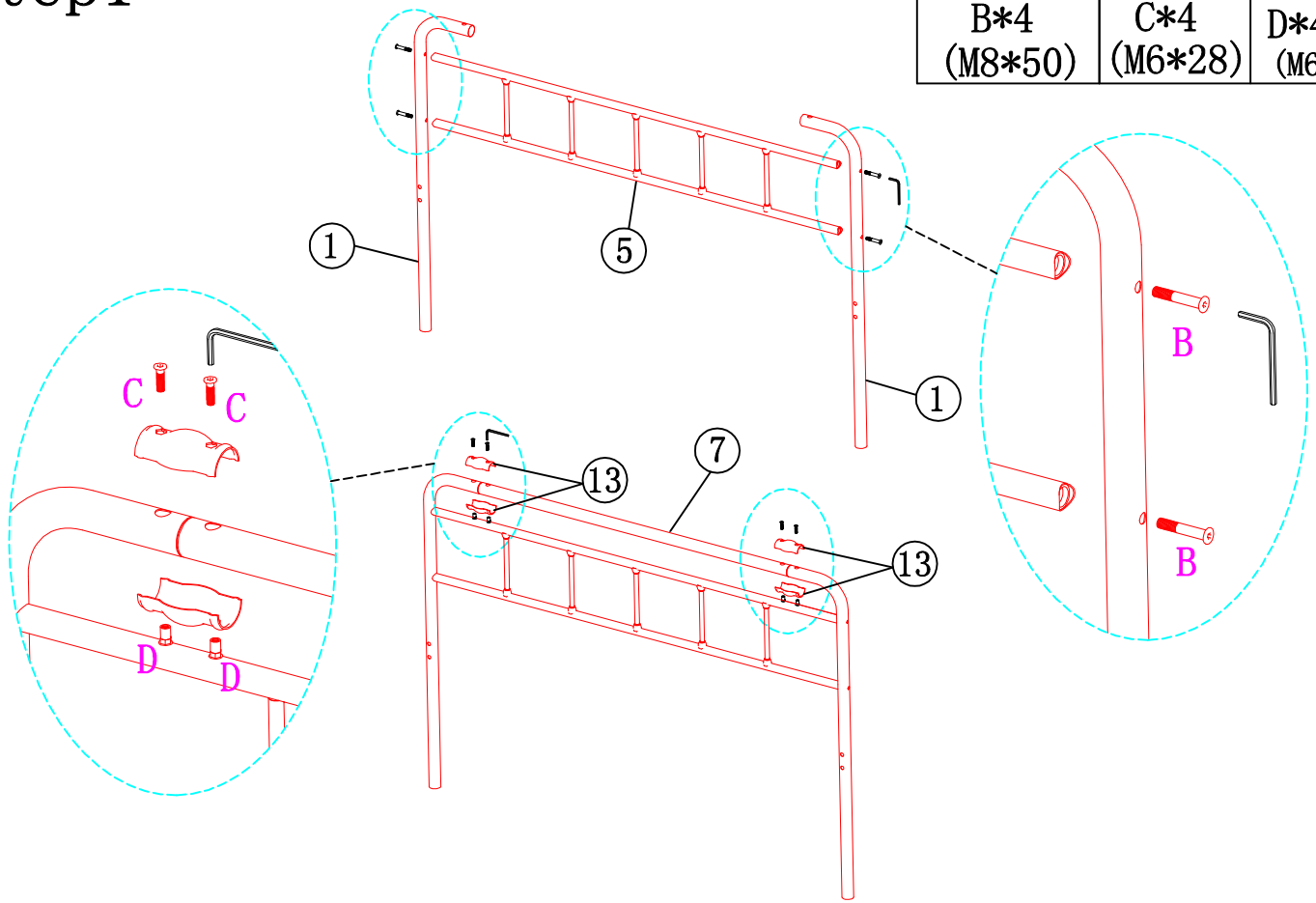
		
B*4 (M8*50)	C*4 (M6*28)	D*4 (M6)



Step2

		
B*4 (M8*50)	C*4 (M6*28)	D*4 (M6)

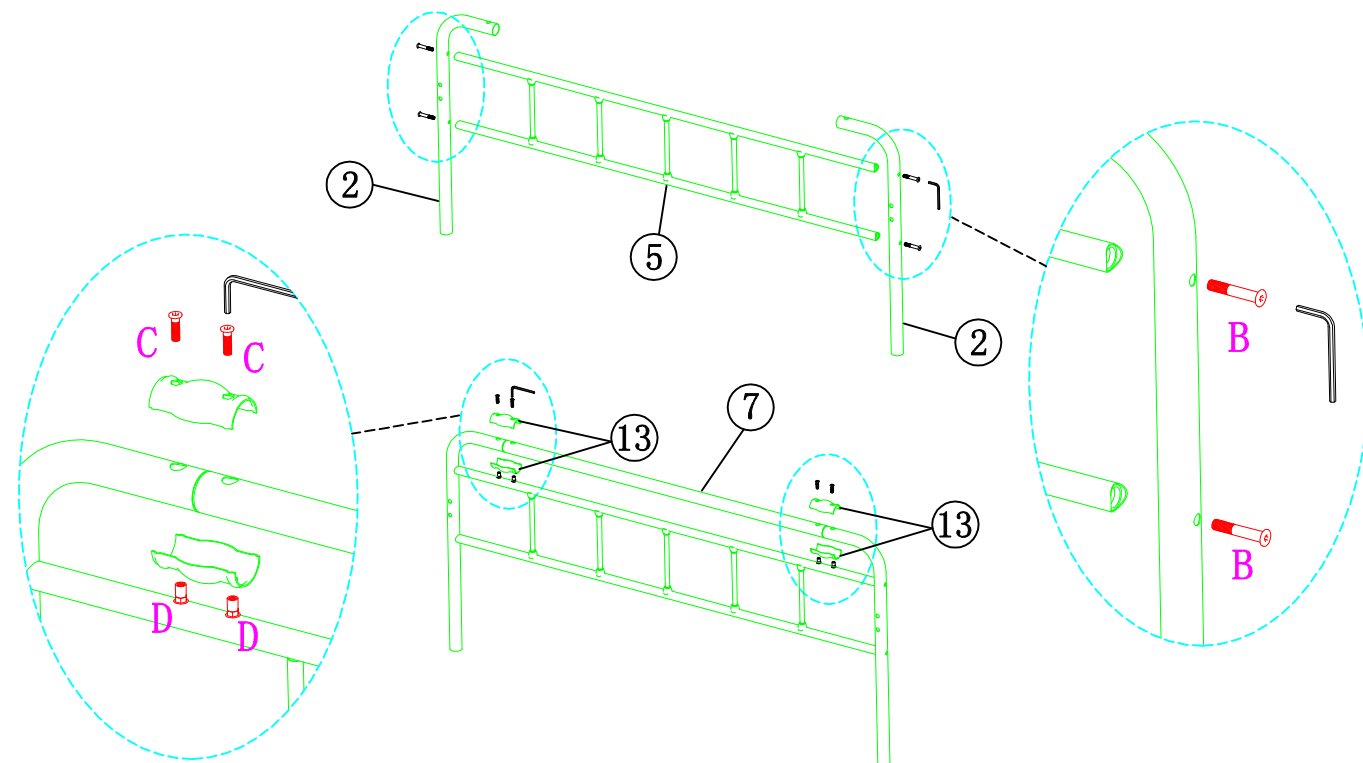

Step3

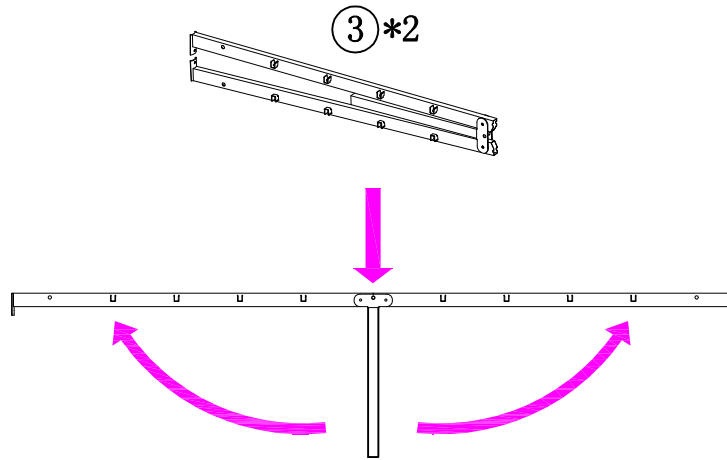
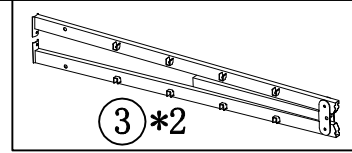

Step4

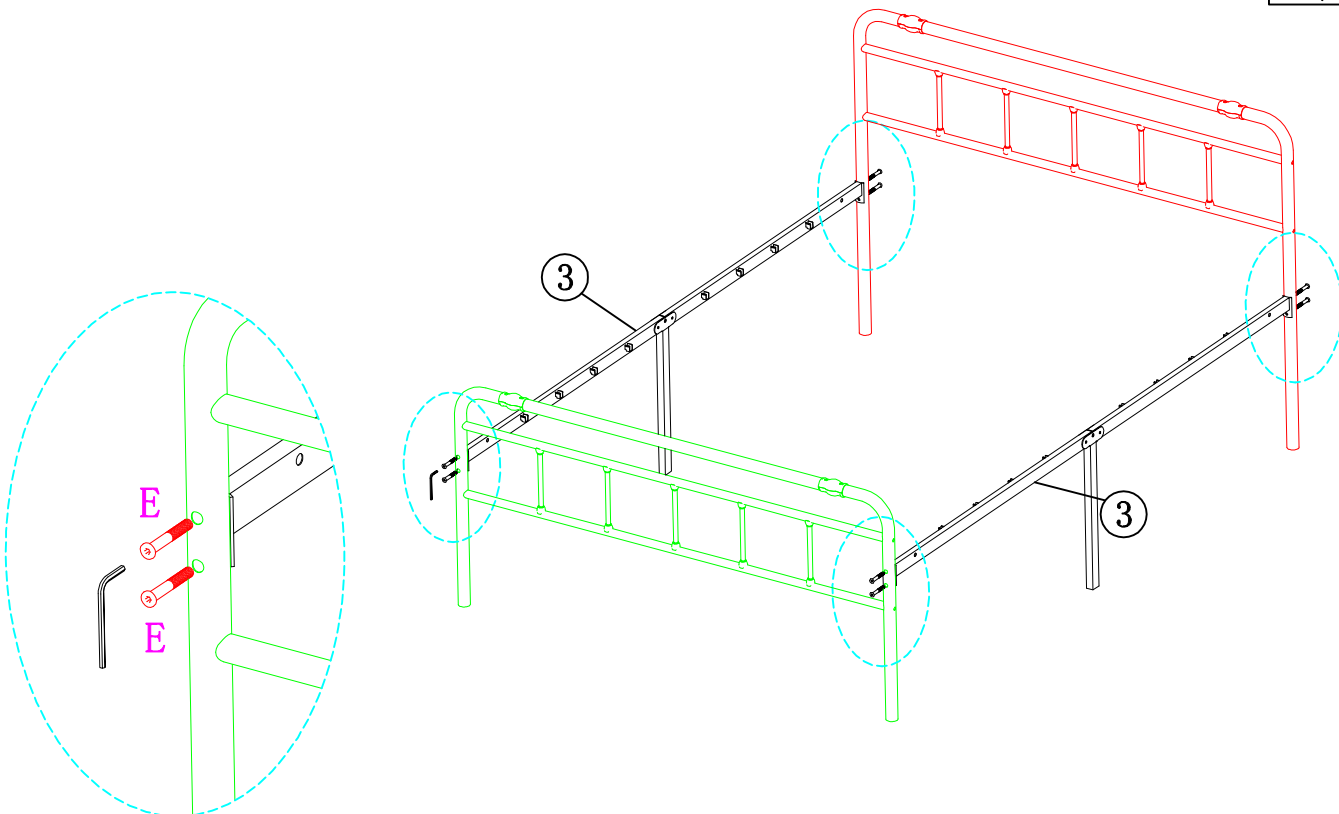
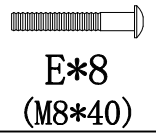

Step5



F*4
(M8*35)

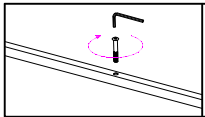
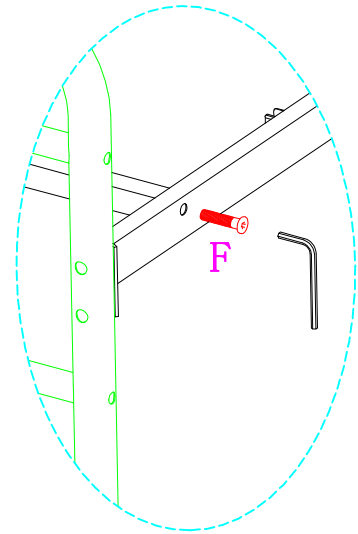
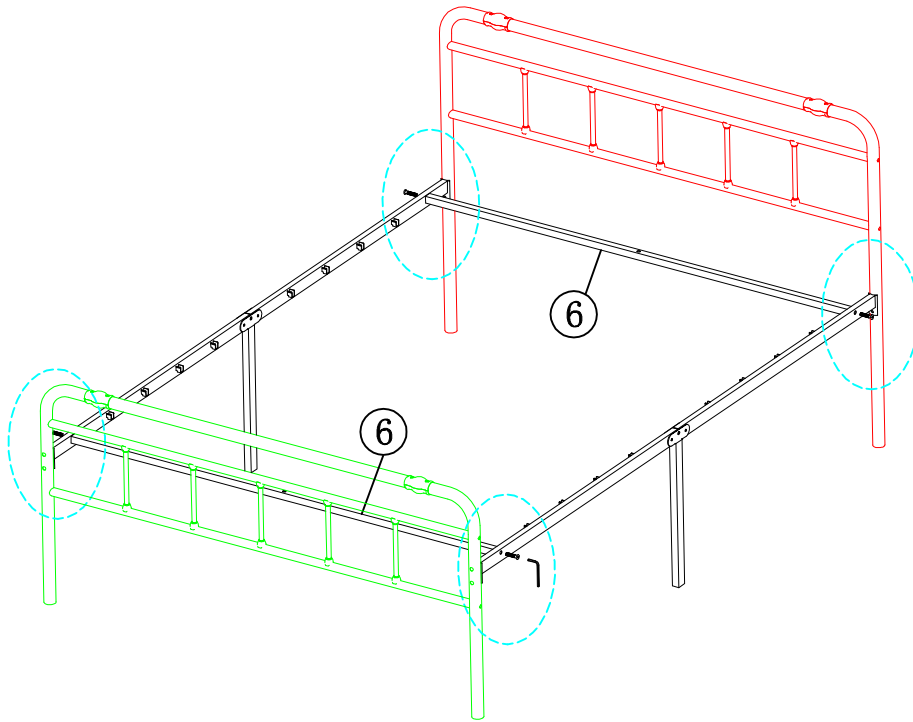

⚠ Do not fully tighten the screws yet.

Step6

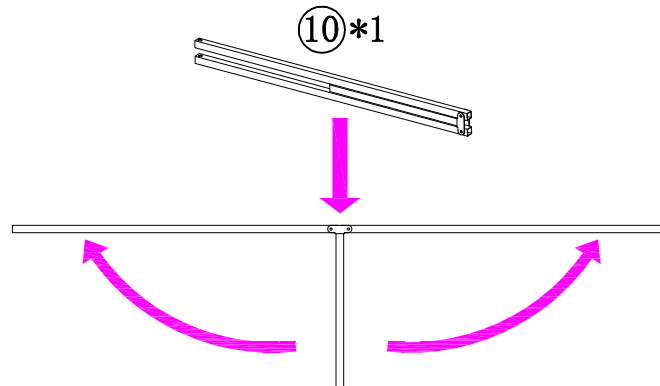
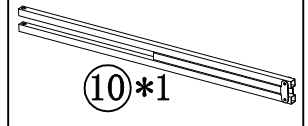

Step7

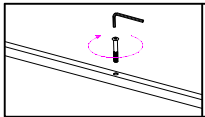
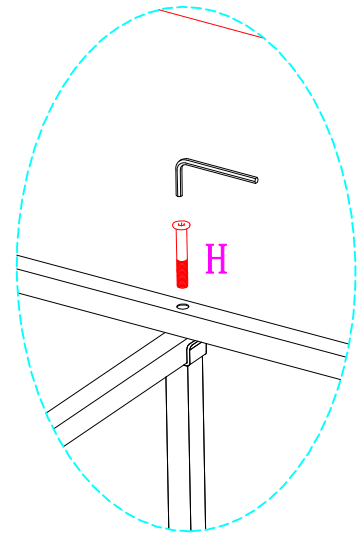
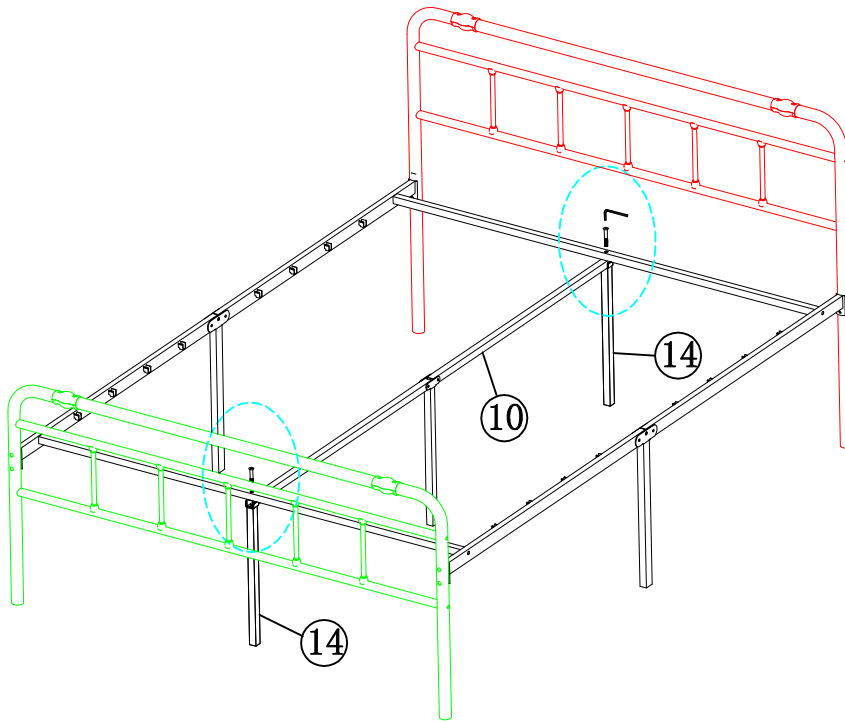
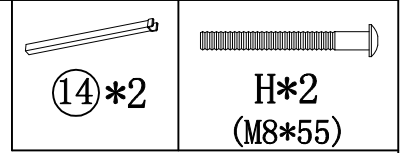

⚠ Do not fully tighten the screws yet.

Step8

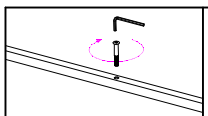
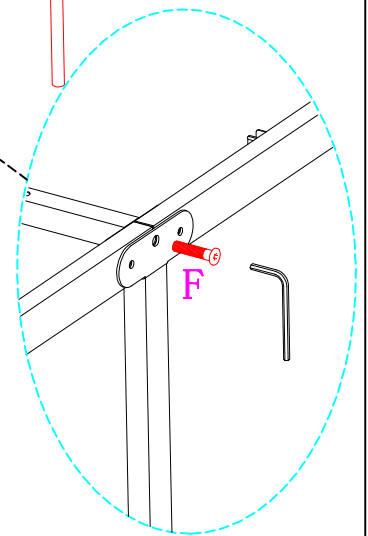
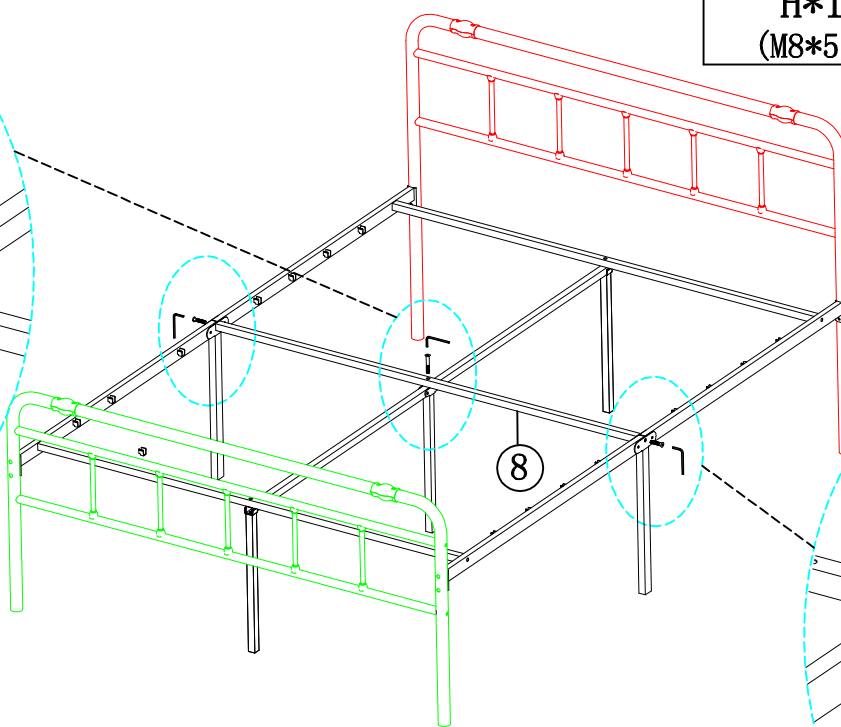
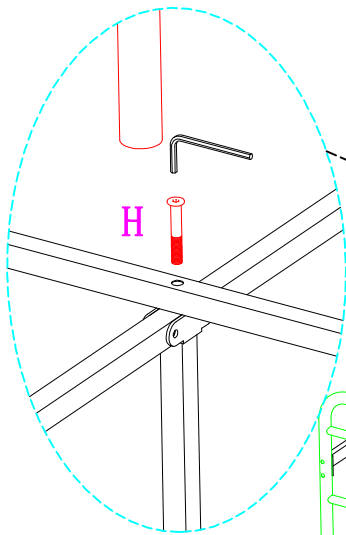
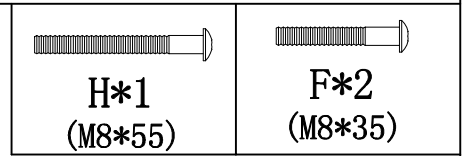

⚠ Fully tighten all the screws



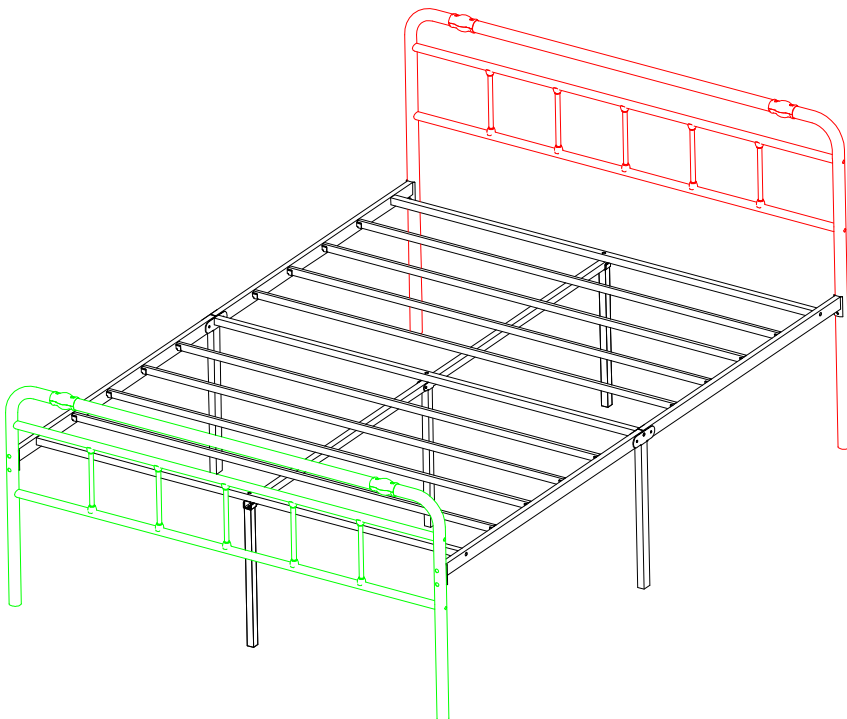
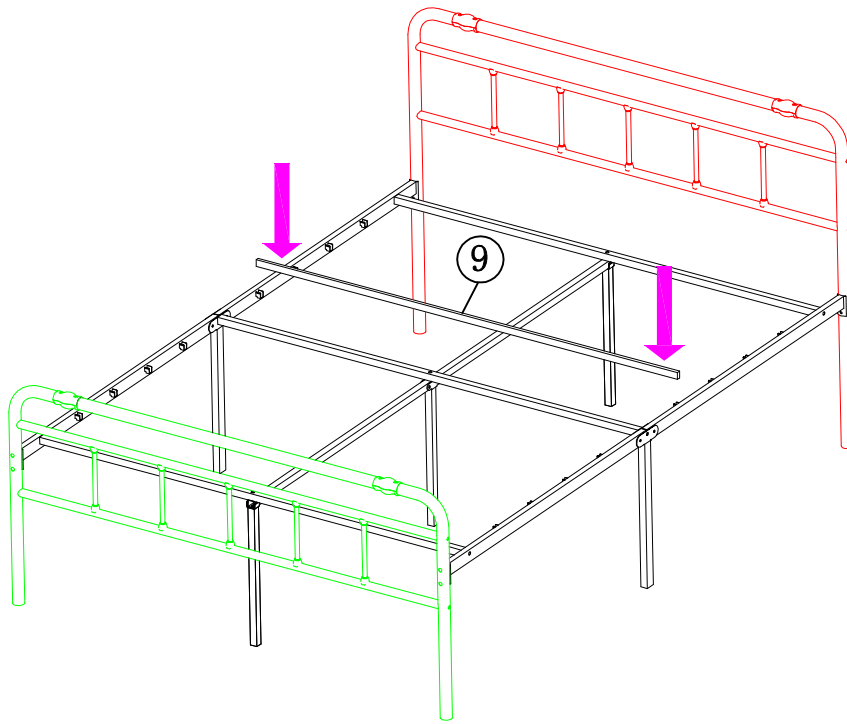
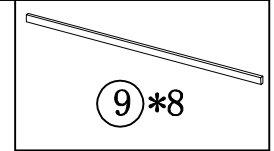





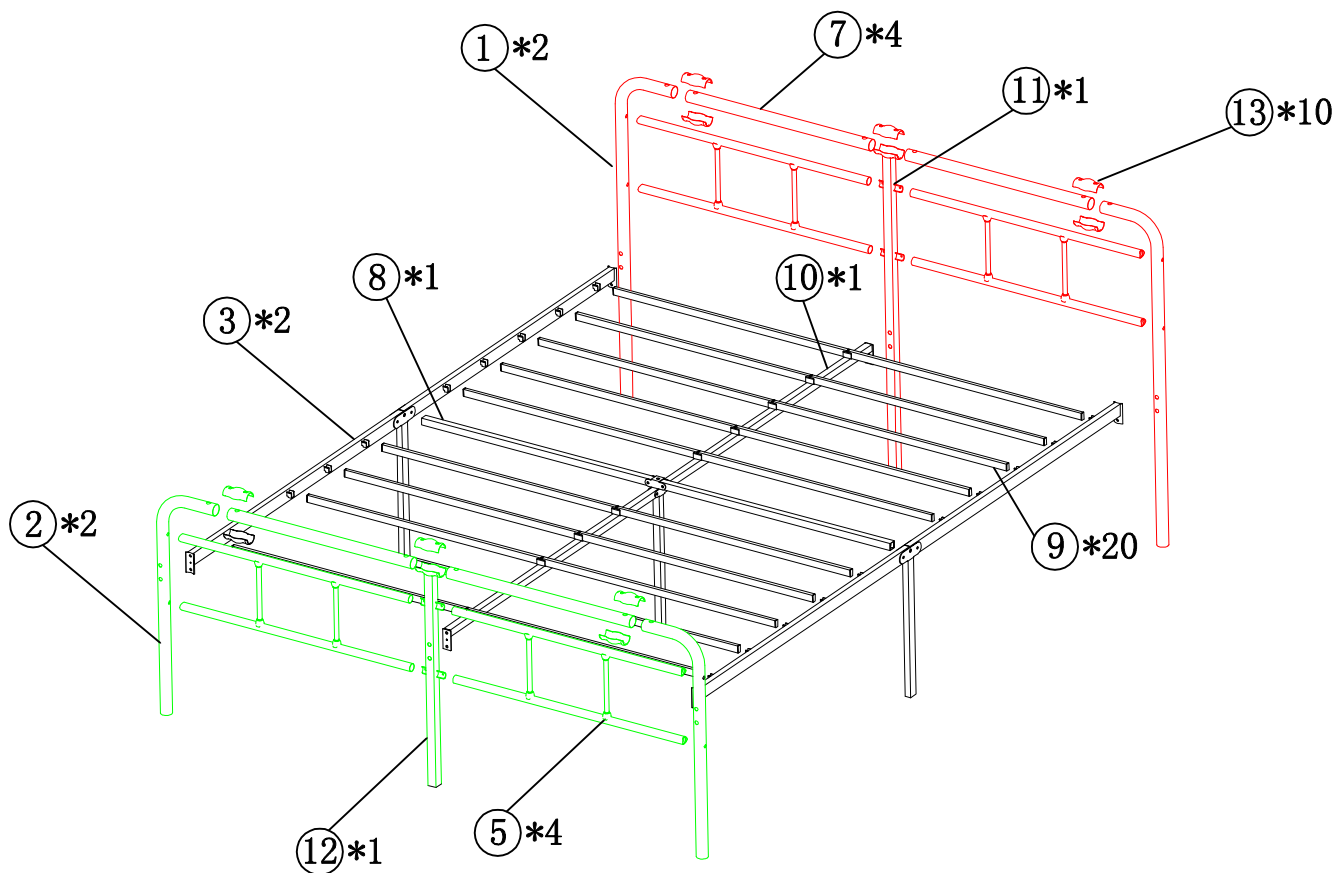

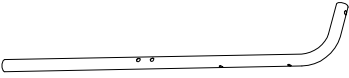

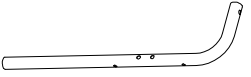
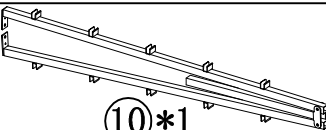

Step9

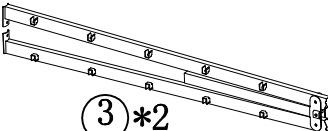

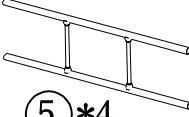
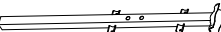

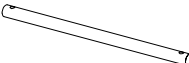
[Back to Top](#)

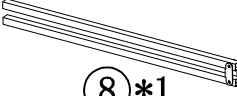
In the last step. please make sure all the screws are tightened.





 <p>①*2</p>	 <p>⑨*20</p>	 <p>A*8 (M6*10)</p>	 <p>H*1 (M8*55)</p>
 <p>②*2</p>	 <p>⑩*1</p>	 <p>B*8 (M8*50)</p>	 <p>K*1</p>
 <p>③*2</p>	 <p>⑪*1</p>	 <p>C*12 (M6*28)</p>	
 <p>⑤*4</p>	 <p>⑫*1</p>	 <p>D*12 (M6)</p>	
 <p>⑦*4</p>	 <p>⑬*10</p>	 <p>E*8 (M8*40)</p>	
 <p>⑧*1</p>		 <p>F*6 (M8*35)</p>	

Step1

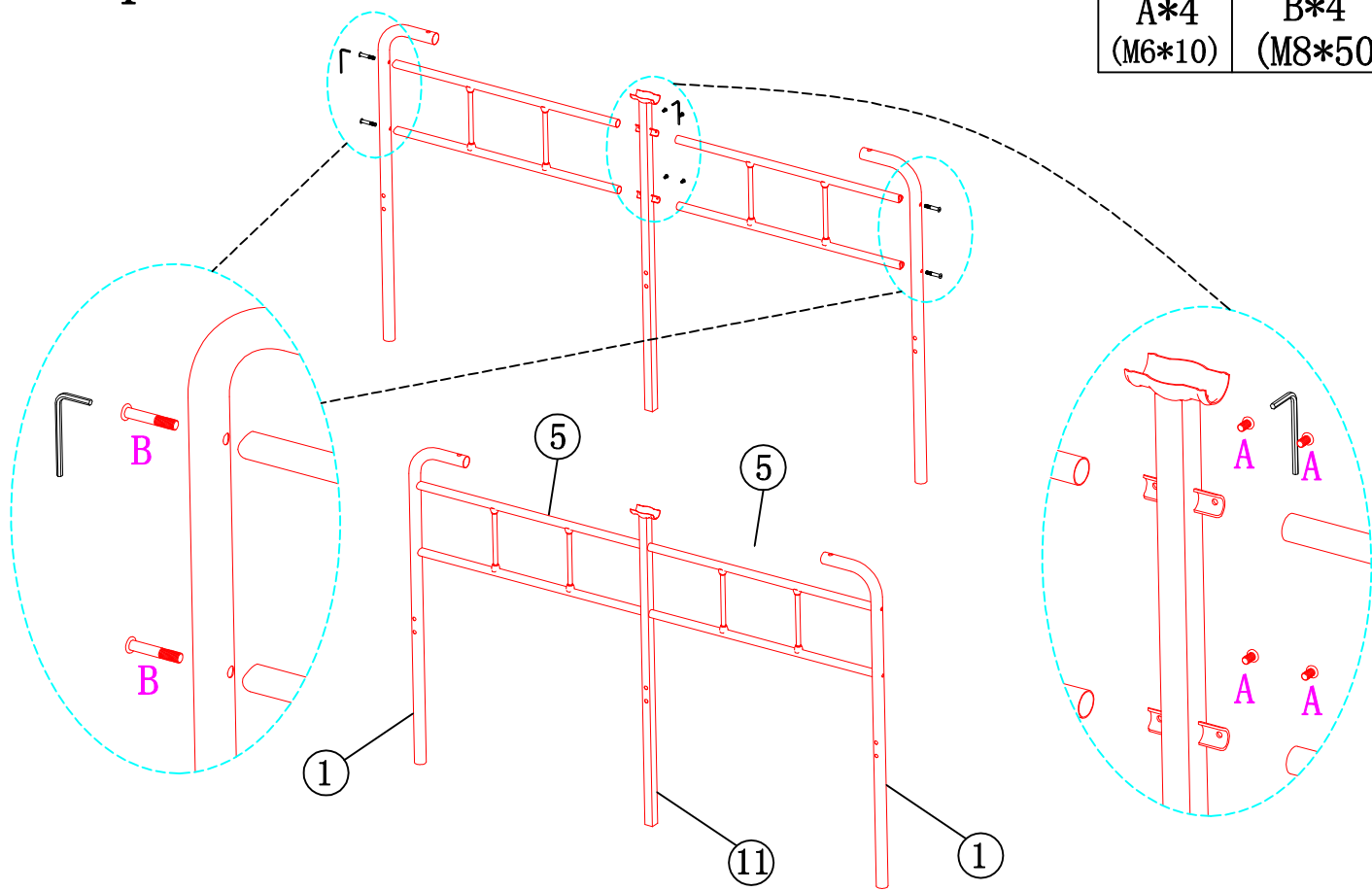
	
A*4 (M6*10)	B*4 (M8*50)



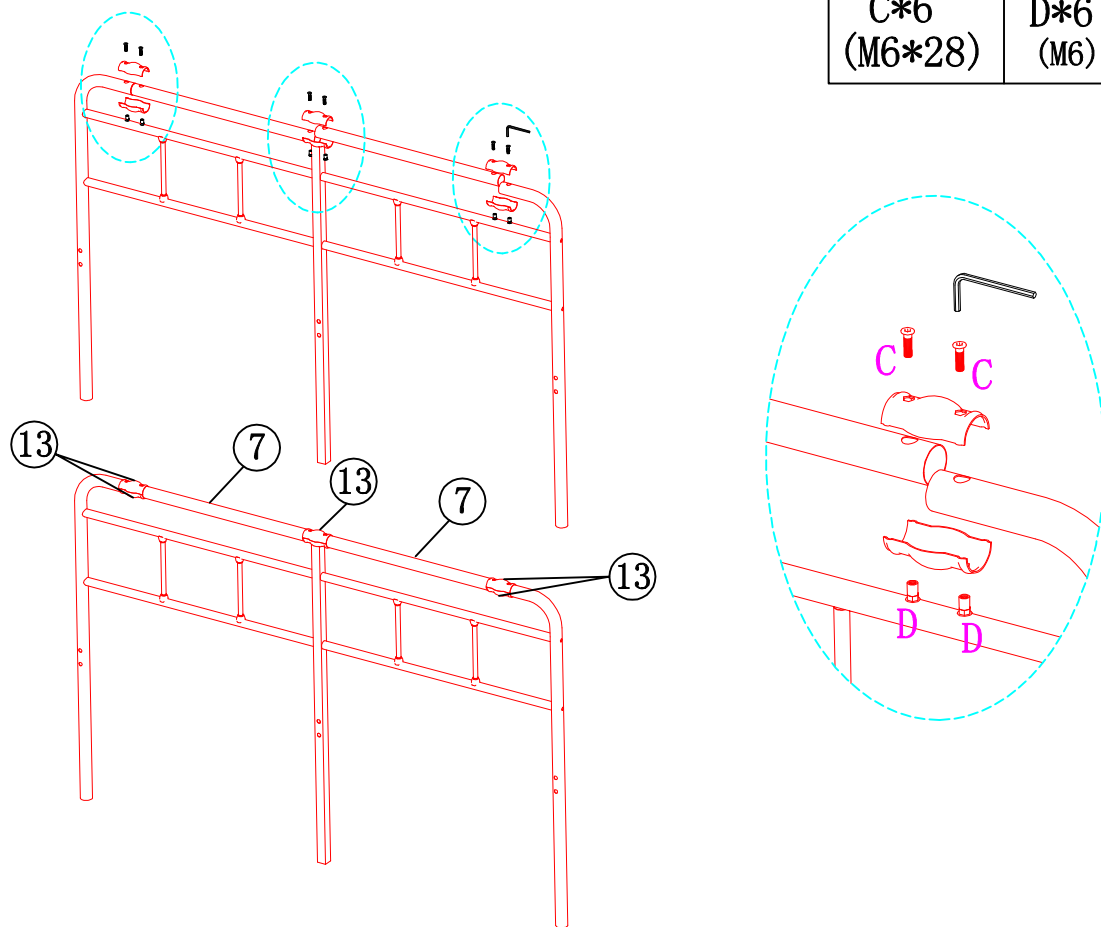

Step2

	
C*6 (M6*28)	D*6 (M6)



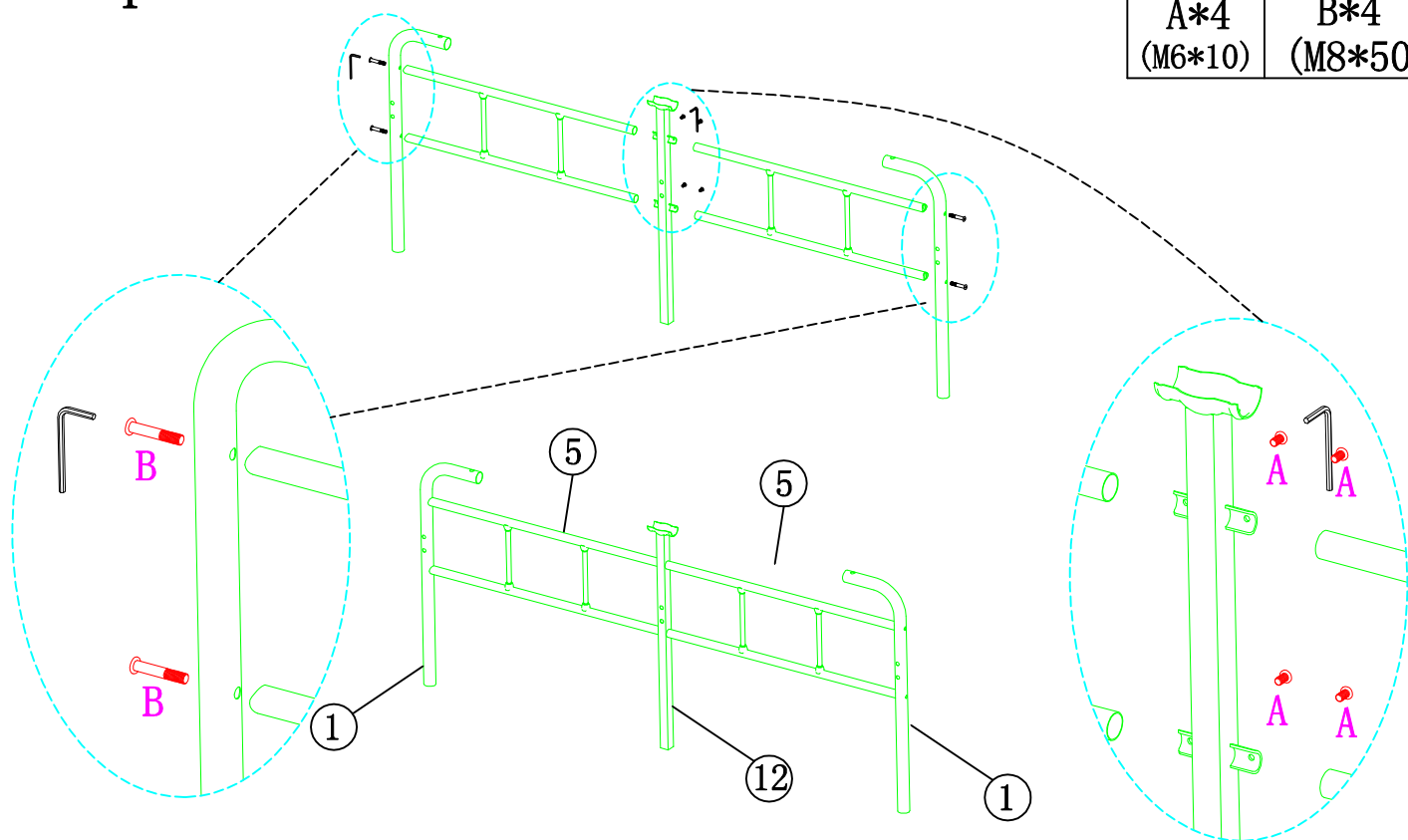

Step3

	
A*4 (M6*10)	B*4 (M8*50)



Step4

	
C*6 (M6*28)	D*6 (M6)

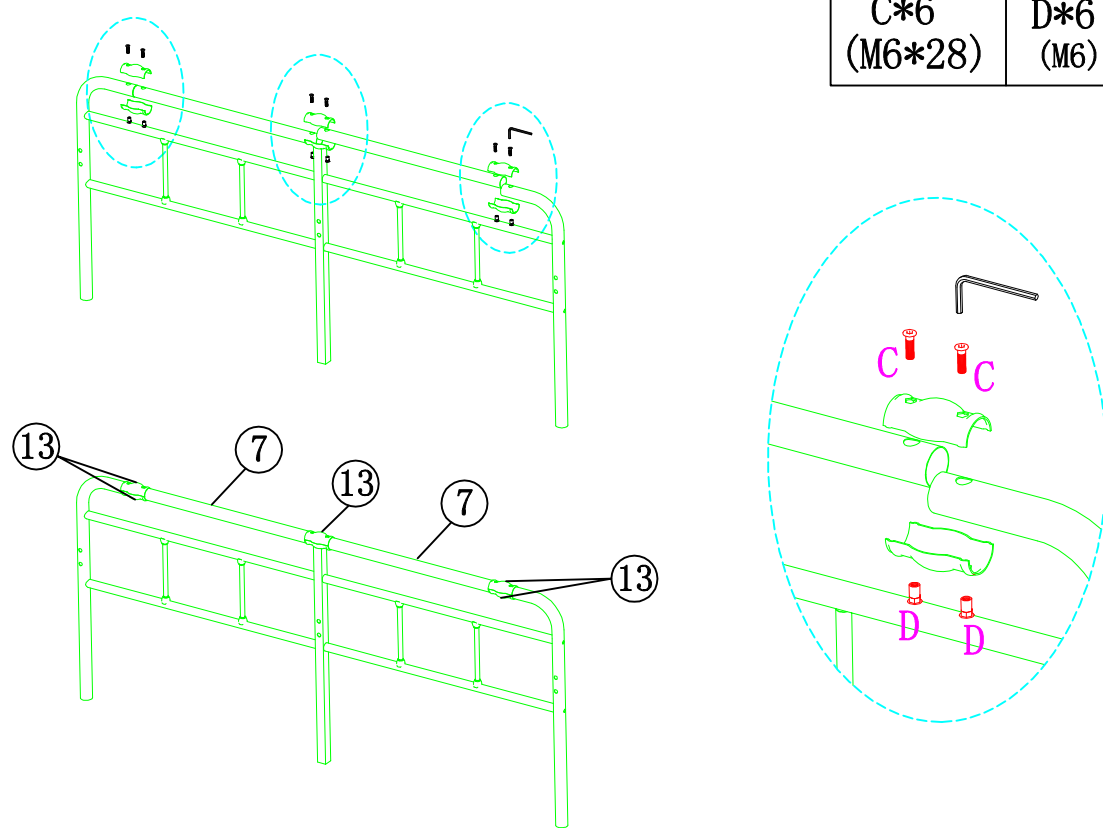

Step5

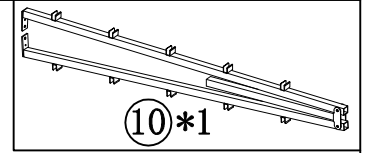

⑩*1

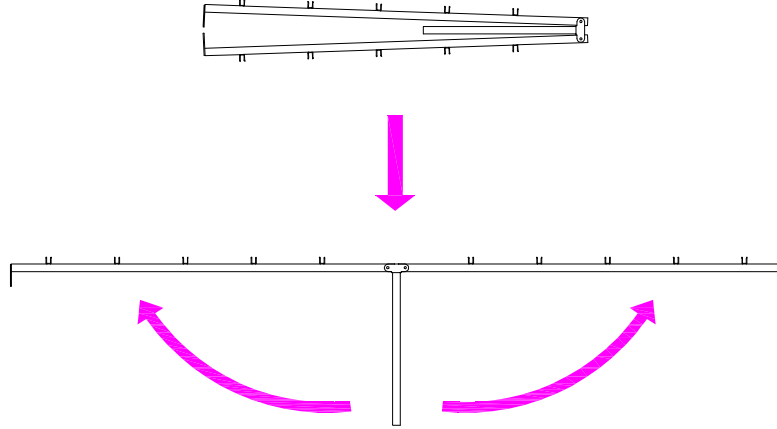

Step6



F*4
(M8*35)

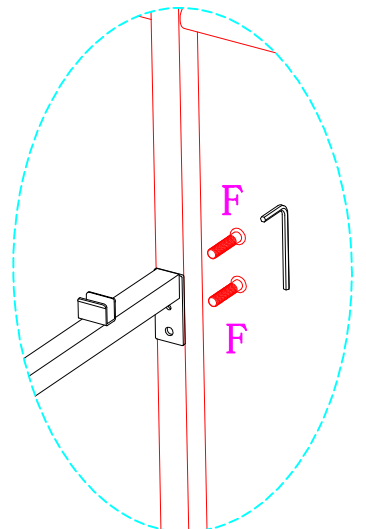
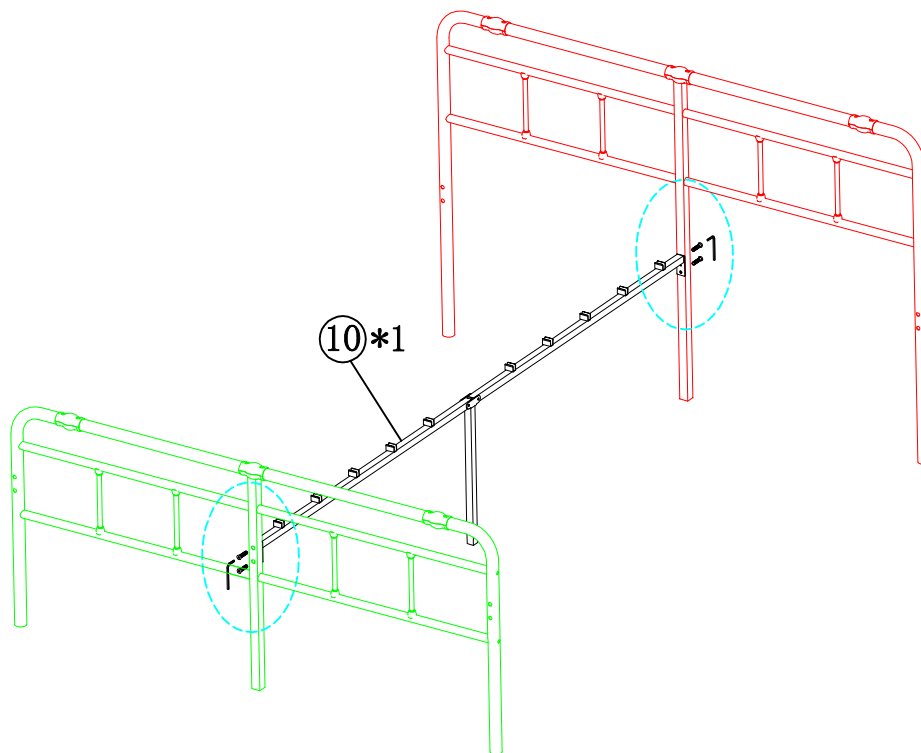

Step7

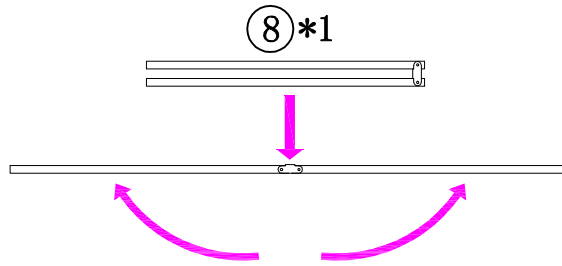
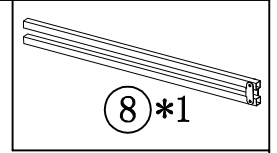

Step8

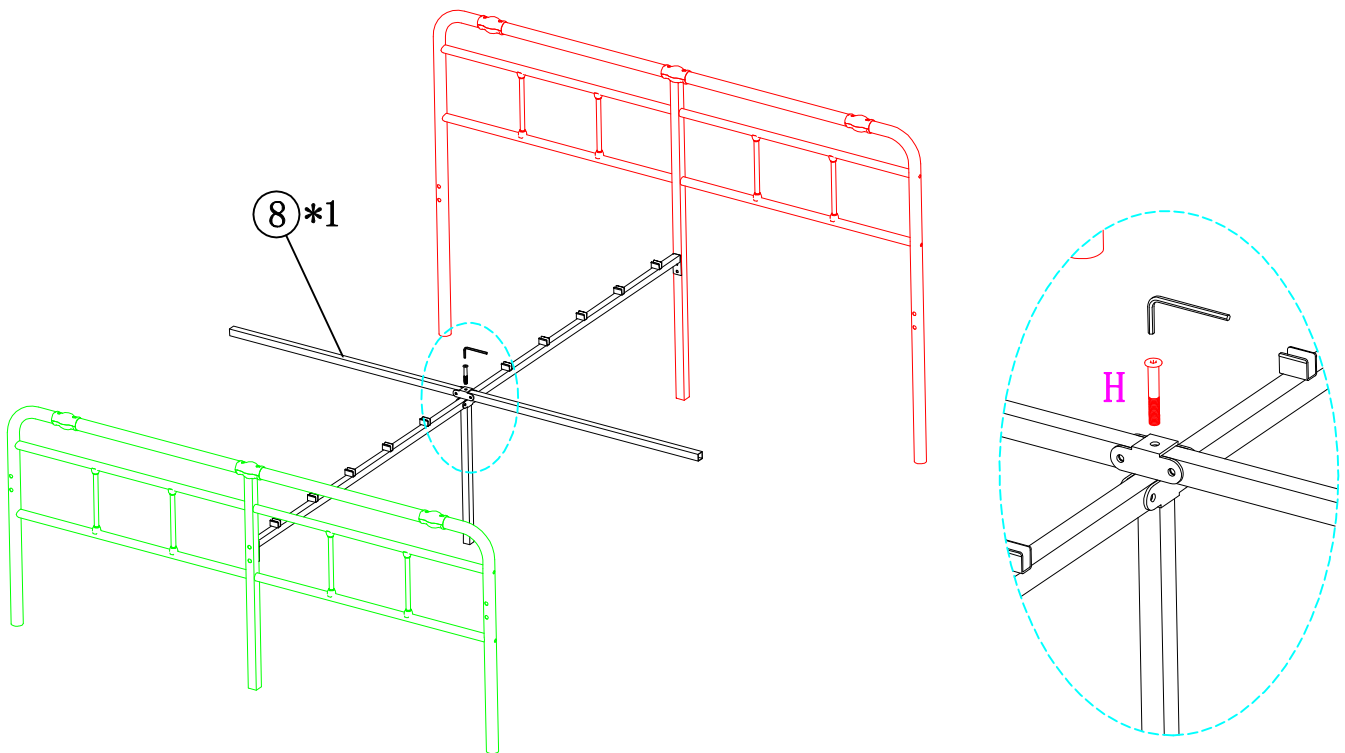
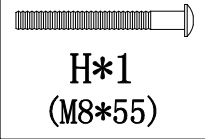

Step9

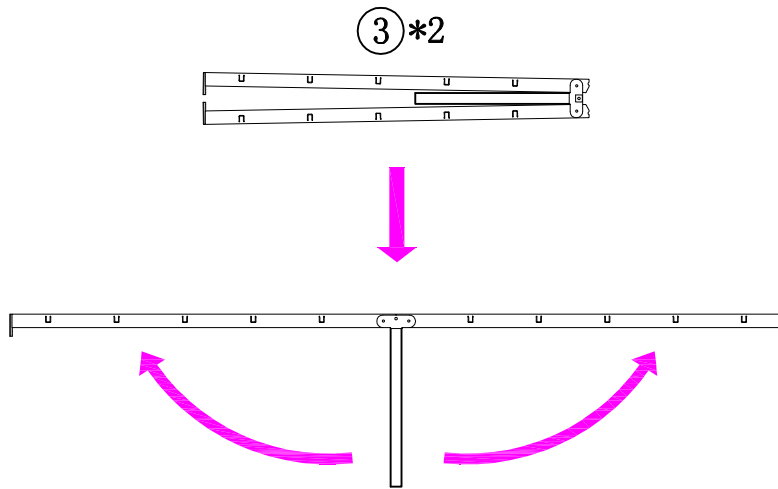
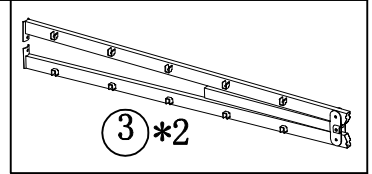

Step10



E*8
(M8*40)



F*2
(M8*35)

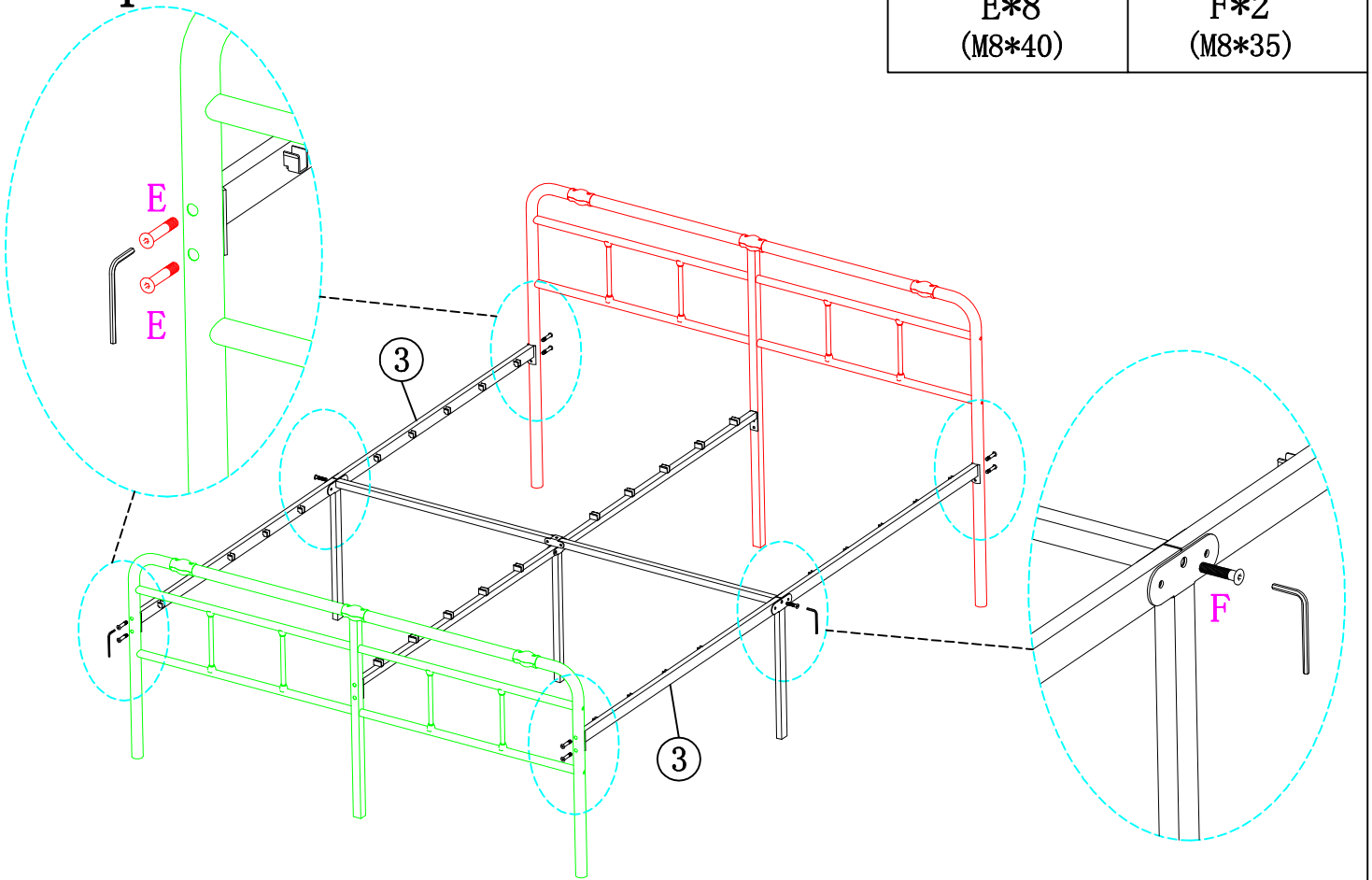

Step11

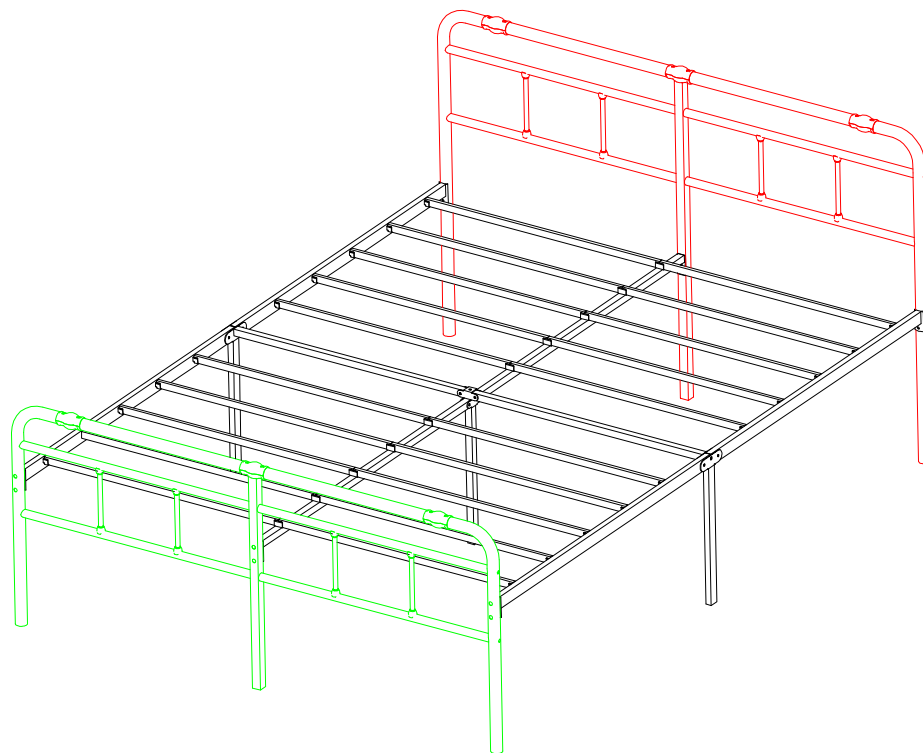
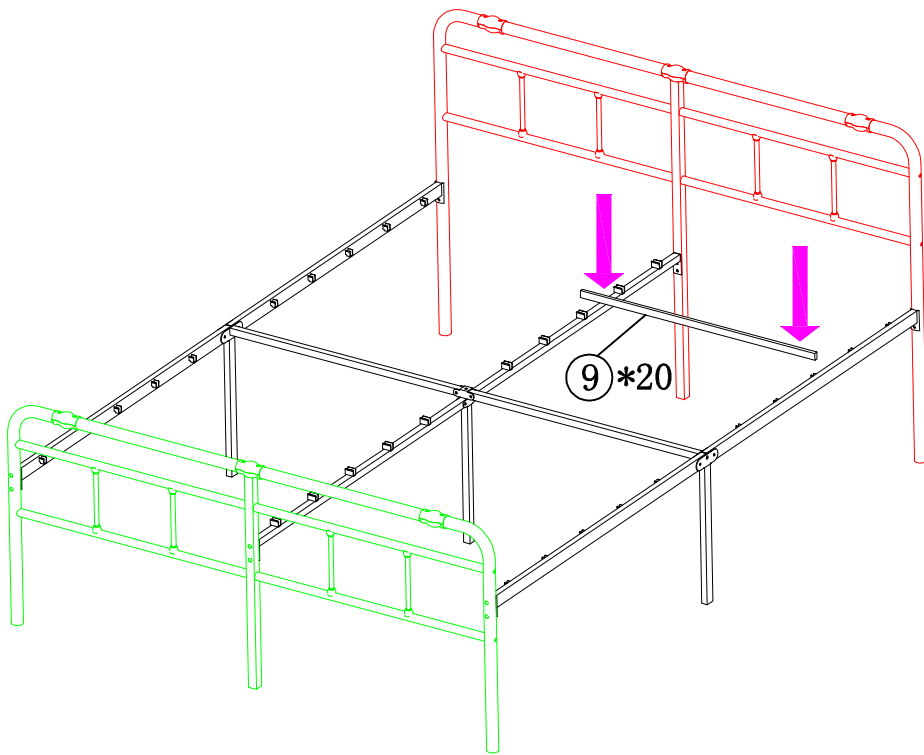
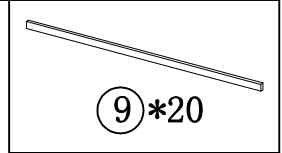

[Back to Top](#)

In the last step. please make sure all the screws are tightened.