

ASSEMBLY INSTRUCTIONS

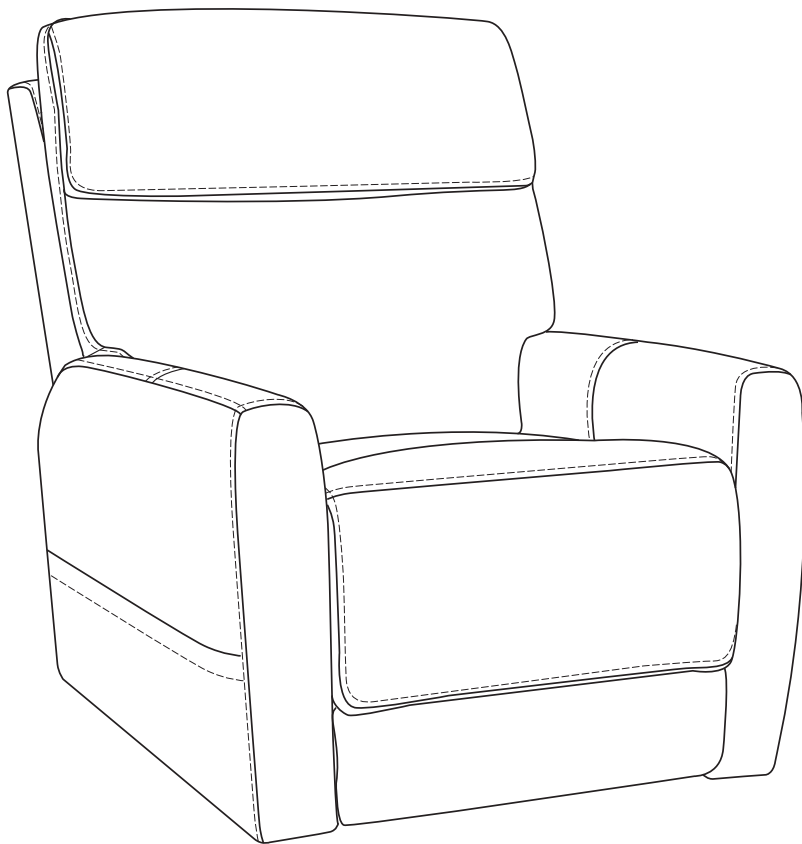

TOOLS REQUIRED



Screwdriver
(Not included)

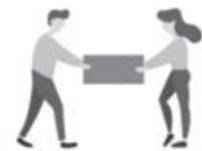

2 - People

ASSEMBLY RATING



EASY —————> DIFFICULT

The Assembly Rating is a 5-point system showing the level of effort needed to assemble a specific product.



CHECK BEFORE STARTING

Are you missing anything?

Double-check all parts, hardware and accessories listed are all accounted for.

Check out our Quick Tips!

We recommend reviewing the pre-assembly handouts. Even experts need a refresher now and then!

Should we send any replacements?

Are there any irregularities or flaws in the parts? We can send replacements!

Prep Time!

Please review the assembly instructions and all diagrams prior to assembling.

PRE ASSEMBLY INTRODUCTION

We understand building ready-to-assemble furniture can be a challenging experience for some. To help avoid confusion, we have provided some helpful tips that may speed up the process.



Teamwork

ALWAYS have at least two people to help with transporting and assembling the product to avoid potential injury and/or damage.



Suitable Location

Assembling near the area of the intended location is highly recommended.



Sufficient Space

Make sure you have enough space to move around during the assembly.



Avoid Scratches

Use cardboard, blankets or a carpeted area while assembling furniture to prevent to prevent scratches and damages.



Flat Surface

Make sure the furniture rests on a flat and level surface with each leg evenly touching the floor.

ASSEMBLY AND CARE ADVICE



FAILURE TO FOLLOW THE GUIDELINES BELOW MAY RESULT IN INJURY AND/OR PROPERTY DAMAGE.



Position each part correctly and insert screws or bolts into their respective holes.

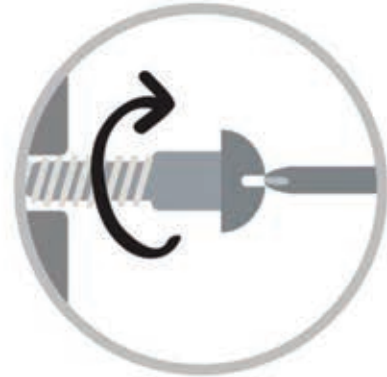

Turn clockwise to tighten and only tighten when step is completed or when instructed to do so.



Use the appropriate hand tools or power tools for assembly. Select steps, such as tightening screws and/or bolts, may require hand tools to avoid causing damage during assembly.



Save the instructions and store any supplied tools for later maintenance.



After two weeks, check and tighten any loose hardware and repeat again every six months thereafter.

IT IS THE USER'S RESPONSIBILITY TO MAINTAIN THE FURNITURE. THE HARDWARE MAY LOOSEN OVER TIME AND MAY CAUSE THE FURNITURE TO BE WOBBLY AND UNABLE TO SUPPORT ITS INTENDED WEIGHT CAPACITY. THIS MAY LEAD TO COLLAPSE AND MAY CAUSE SERIOUS INJURY.

LIFT CHAIR



- Please keep instructions for future reference.
- Check the quantity and irregularity of parts and hardware before you start.

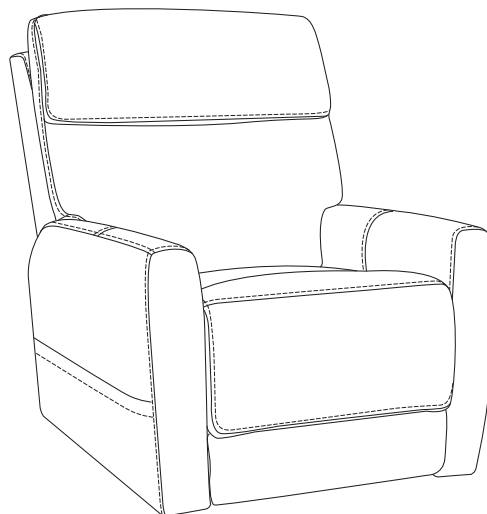

PARTS

1

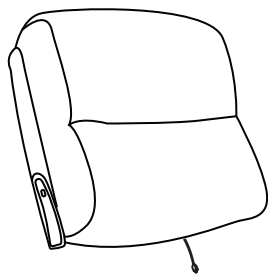

Back Cushion
1 pc.

2

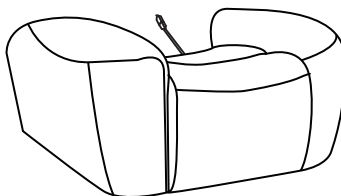

Seat Cushion
1 pc.

3



Wing
2 pc.

HARDWARE

A

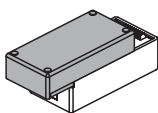

Wall Plug Transformer
1 pc.

B



Power Cord
1 pc.

C



Hand Wand
1 pc.

ASSEMBLY INSTRUCTIONS

CAUTION: PLEASE READ ALL INSTRUCTIONS CAREFULLY BEFORE STARTING ASSEMBLY PROCESS. IT IS RECOMMENDED TO USE TWO PEOPLE WHEN ASSEMBLING AND REMOVING THE INSIDE BACKS TO AND FROM THE BASE OF THE FURNITURE.

Once the box has been removed from around the chair, you'll notice the back is laying on top of the seat. There are a couple items to remove from the seat portion of the chair first. Follow the steps below:

- 1** Remove the zip tie holding the foam bag with the Power Transformer, its cord and the remote on the left. (See Figure 1.1)

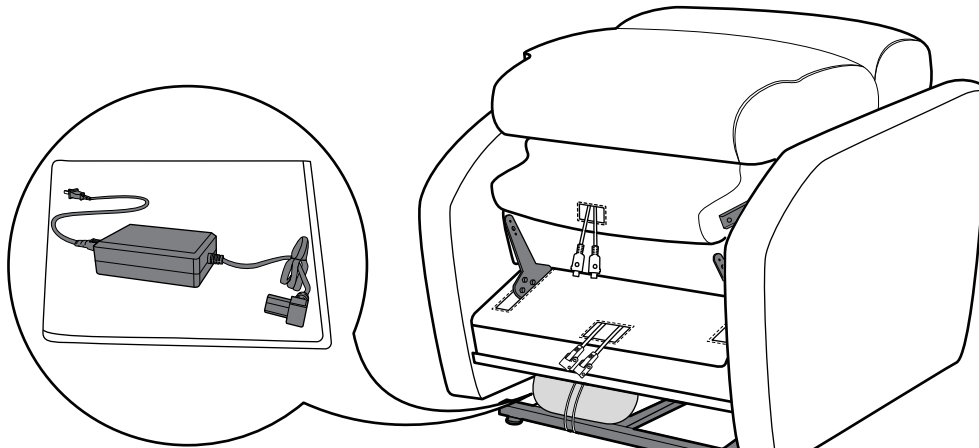

Figure 1.1

- 2** Slide inside back receivers onto the steel mechanism posts in the base of the chair. (See Figure 2.1)
Press both sides of the back firmly into place until the back automatically locks into track. (See Figure 2.2)

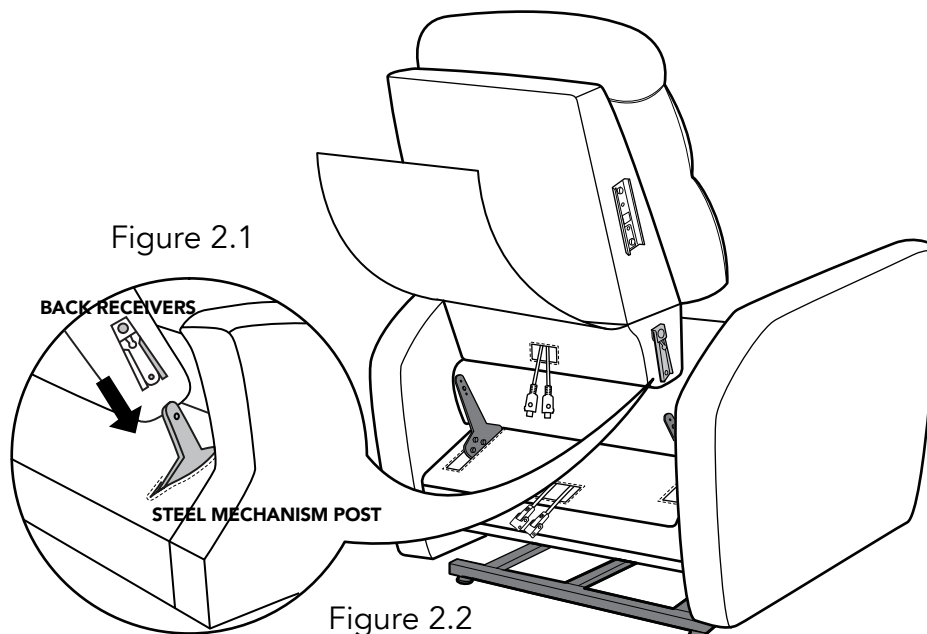

Figure 2.2

ASSEMBLY INSTRUCTIONS

3 For Power Lift Recliners, tuck the fabric flaps on the front of the chair back and rear of the chair base down into the frame and secure with the reusable fastener on each flap. Then, zip the two sections together.

(See Figure 3.1)

*If there is no zipper between the backrest and the cushion, skip this step.

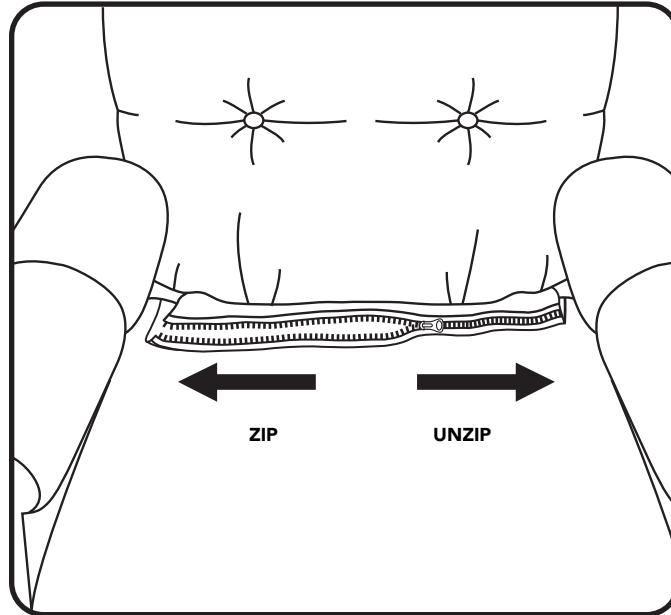

Figure 3.1

4 Connect the Headrest and Lumbar cable plugs (See Figure 4.1). Headrest-only models have only one set of cables. Connect the Air Massage, Power Supply, Heat and Vibrator cable plugs if available. (See Figure 4.2)

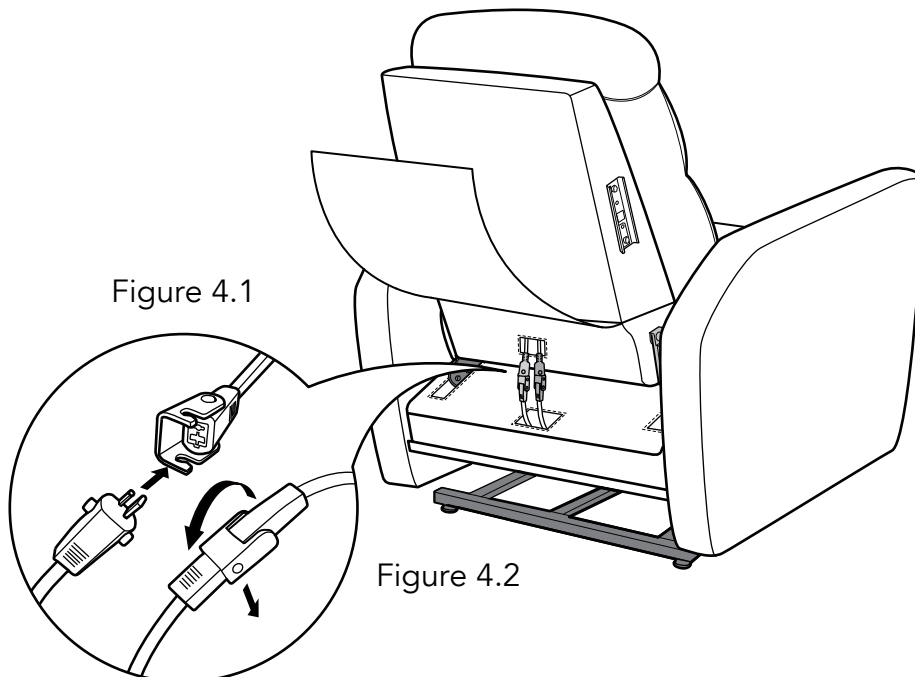

Figure 4.1

Figure 4.2

ASSEMBLY INSTRUCTIONS

- 5** Attach the chair-back to the hook and loop aps on the bottom of the chair base.(See Figure 5.1)

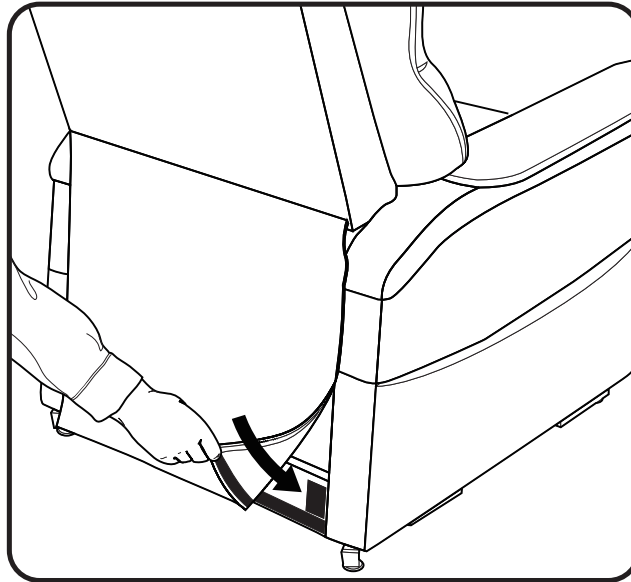

Figure 5.1

Note: your unit may look different in appearance from the one shown in the illustrations on this instruction sheet.

- 6** Slide the metal inserts on the chair's wings into the metal sleeves on the side of the chair back. Slide the wings down until they are completely set on the backs metal sleeves. (See Figure 6.1)

*If this lift chair does not have KD wings, skip this step.

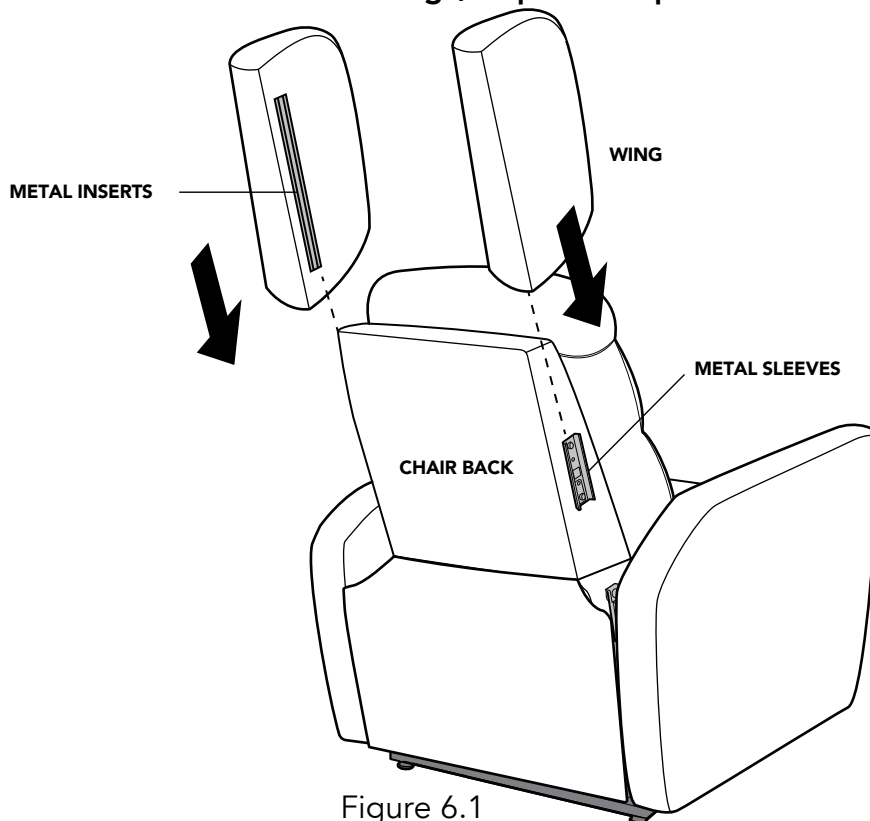
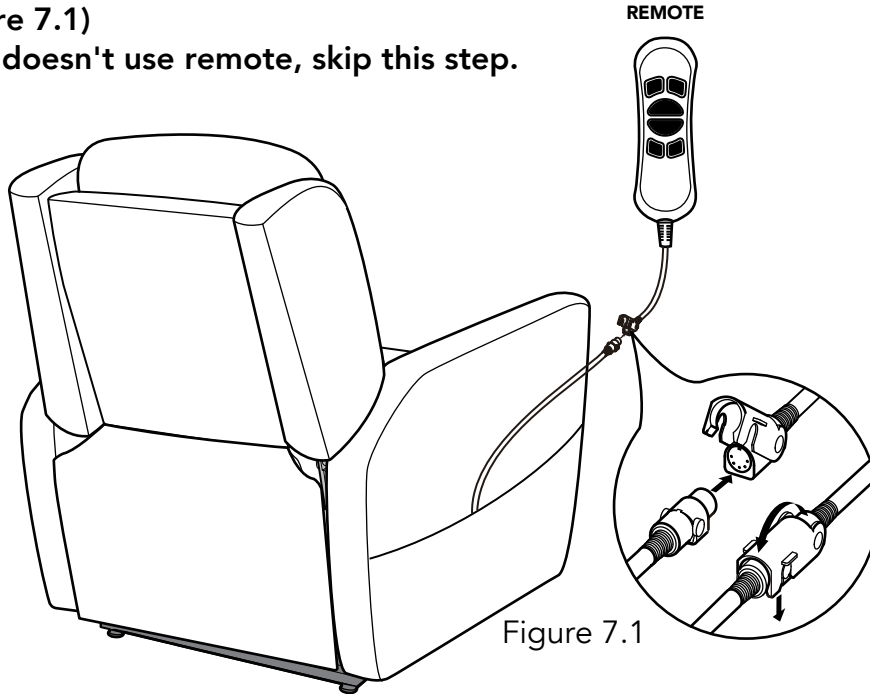

Figure 6.1

ASSEMBLY INSTRUCTIONS

7 Take out the remote from the side pocket of the chair. Remove the remote from the plastic bag and connect it to the female plug located in the outside pocket of the chair. (See Figure 7.1)

*If this lift chair doesn't use remote, skip this step.



8 Connect the Power Transformer to the plug coming from the chair. Connect the Power Cord into the Power Transformer. Connect the Power Cord into an electrical outlet near where the chair will be positioned. (See Figure 8.1)

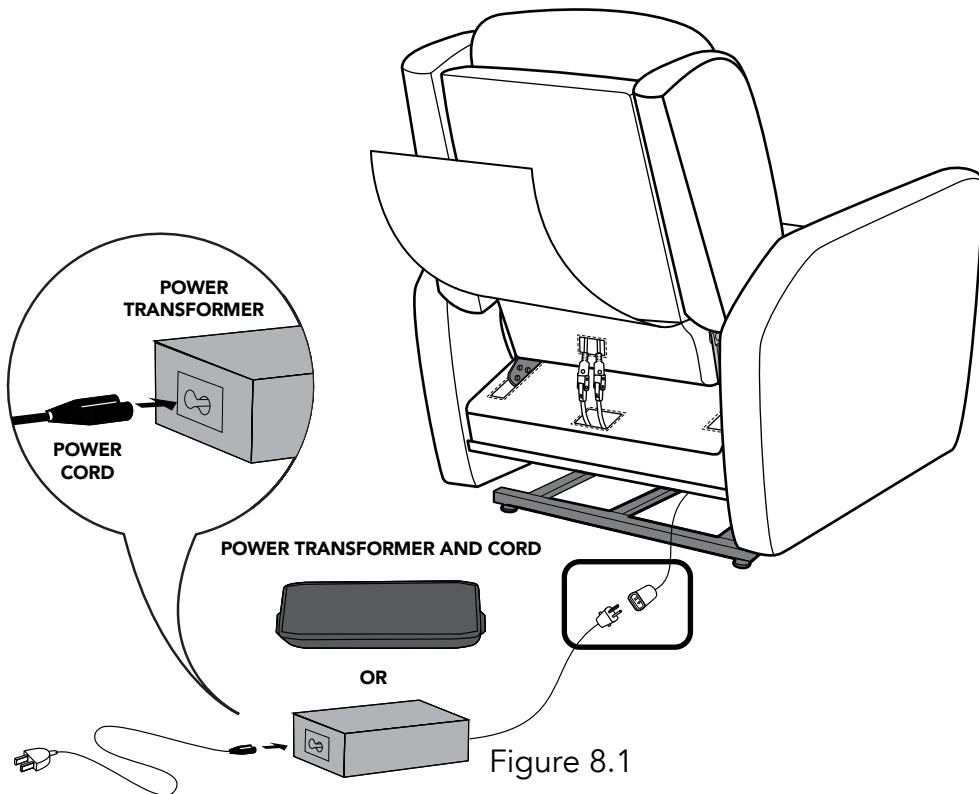

ASSEMBLY COMPLETED

✓ Please ensure the furniture rests on an even and flat surface. If the product wobbles or feels loose, double-check all bolts and/or screws are properly tightened and secured.

- ✓ **Keep this handy!**
Please retain this instruction manual and any order-related information for future reference.
- ✓ **Lift, don't drag!**
To avoid damage to product please always LIFT the product when transporting or adjusting the placement.

TO REMOVE THE BACK FROM THE BASE

To remove the back from the base, use a screwdriver pressing outward on the black tab in the metal receivers on both sides of the chair back and lift the back from the base of the chair to release. (See Figure 9.1)

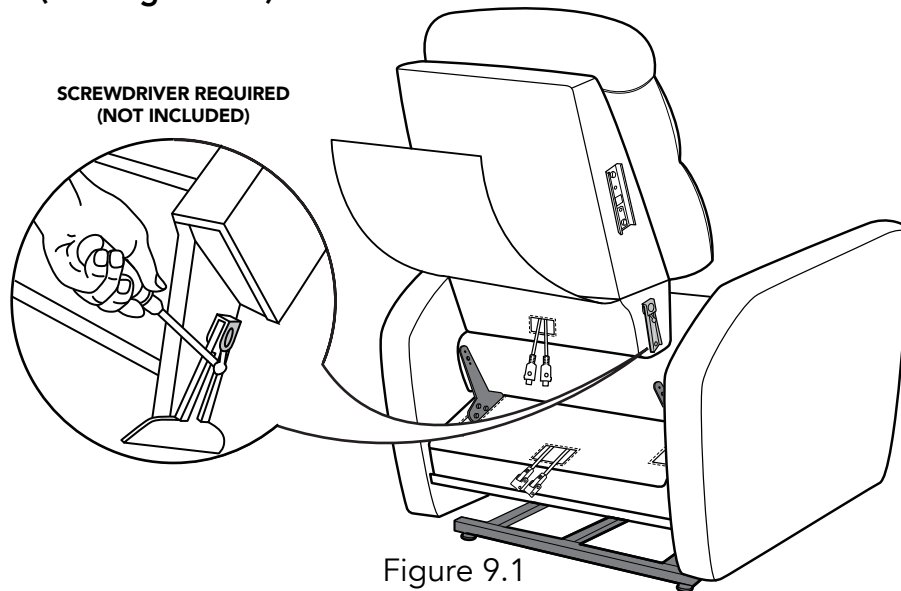

SERIAL LABEL

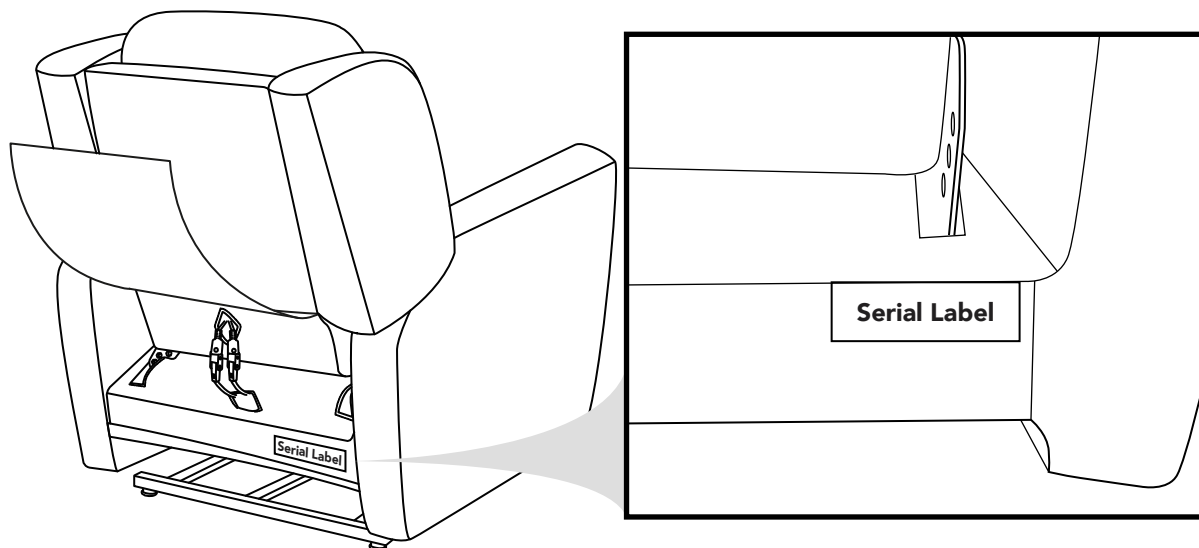

Your serial number label at the rear of the chair, as the picture.

OPERATING INSTRUCTIONS

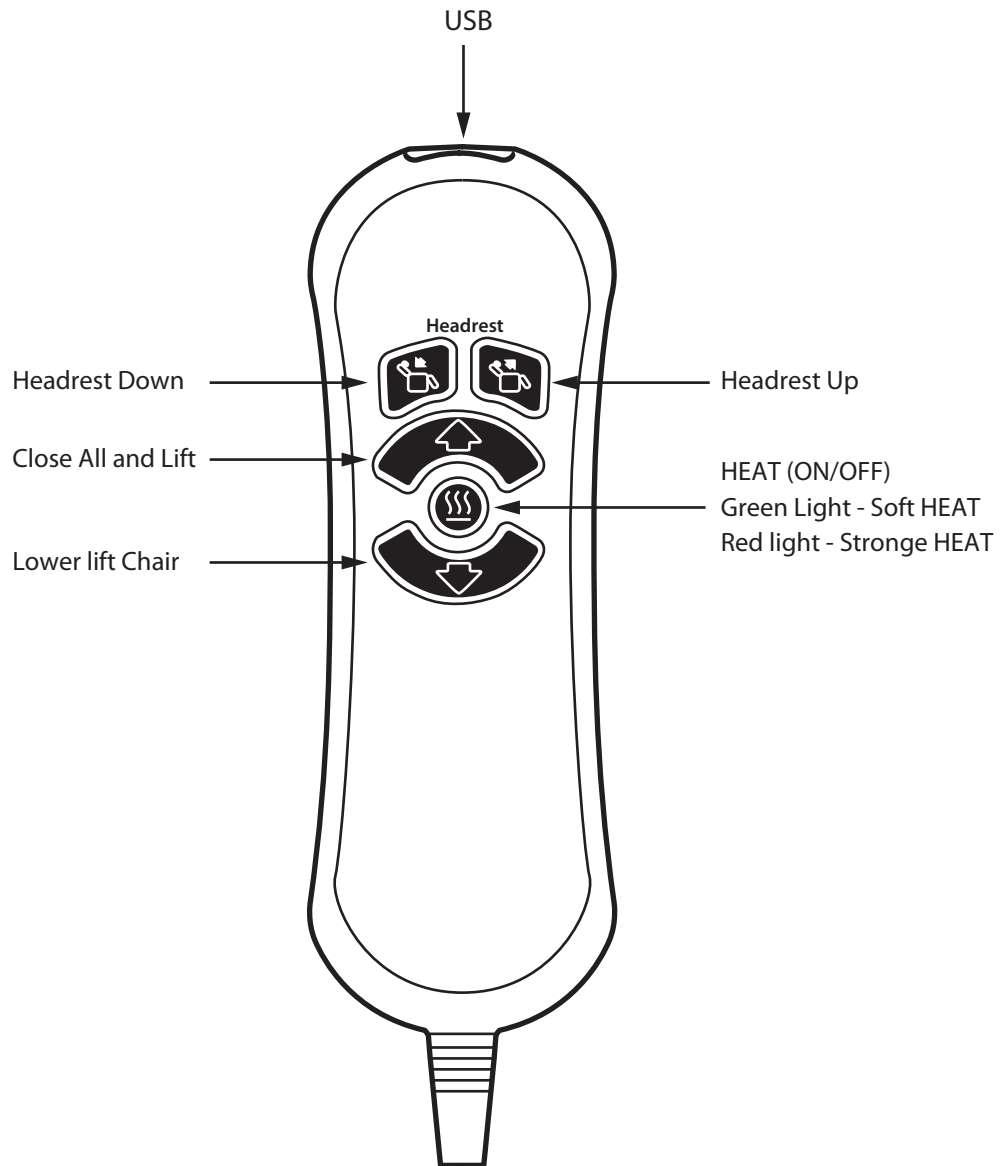

TROUBLE SHOOTING

PROBLEM	POSSIBLE FACTORS	SOLUTIONS
Chair doesn't recliner or lift	Transformer may not connected well	<ul style="list-style-type: none"> • Check the power supply has been correctly connected to socket • Confirm the wire from chair to transformer is firmly connected
Headrest or Lumbar doesn't work	Headrest or lumbar motor may not connected well	<ul style="list-style-type: none"> • Check the headrest and lumbar motor has been correctly connected to socket
Headrest and lumbar work oppositely	Headrest and lumbar motor plug	<ul style="list-style-type: none"> • Check the headrest and lumbar motor has been correctly connected to socket
The remote doesn't work	Remote may not be connected well	<ul style="list-style-type: none"> • Check the remote cord has been correctly connected to plug
APP doesn't work	Out of the range of wireless connection	<ul style="list-style-type: none"> • Close the chair, the effective wireless connection range is ≤ 32.8 Feet
APP doesn't work	The version of APP is not the latest	<ul style="list-style-type: none"> • Update the version and reset the chair

INSTALLATION OF BACK-UP BATTERIES

2 × 9 Volt back-up batteries will lift the chair from the reclined position to the seating position **one cycle** in case of a power failure. If a power failure occurs and the chair is cycled, the 2 × 9 Volts batteries will need to be replaced.

1. Removed the sliding door on the side of the transformer to locate the 2 × 9 Volt batteries.
2. Pull out the 2 × 9 Volt batteries and replace with new batteries.
3. Replace door on the transformer.
4. **Batteries not included.**

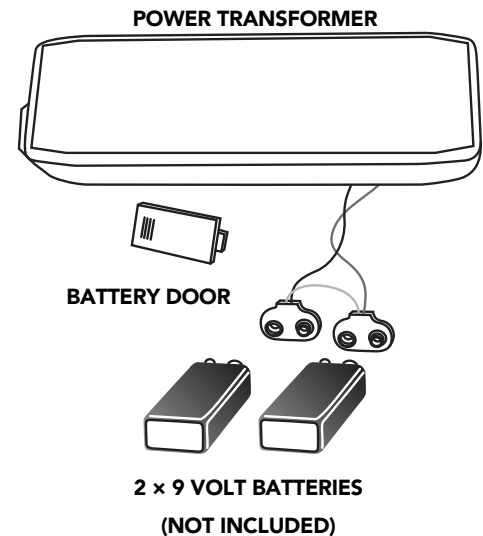

Instructions for use

Always purchase the correct size and grade of battery most suitable for the intended use. Replace all batteries of a set at the same time. Clean the battery contacts and also those of the device prior to battery installation. Ensure the batteries are installed correctly with regard to polarity (+ and -). Remove batteries from equipment that is not to be used for an extended period of time. Remove used batteries promptly.

INSTALLATION OF BACK-UP BATTERIES

4-9 Volt back-up batteries will lift the chair from the reclined position to the seating position **one cycle** in case of a power failure occurs and the chair is cycled, the 4-9 volts batteries will need to be replaced.

1. Remove the sliding door on the side of the transformer to locate the 4 × 9 Volt batteries.
2. Place the battery box on top of the external transformer with the securement grooves toward the external transformer.
3. Slide the battery box onto the external transformer until it clicks into place.

9V Emergency Backup

Provides temporary emergency power in the event of a power outage. Batteries not included. Replace batteries every 6 months to ensure proper function when needed.

DO NOT use with the 29V battery pack.

The enhanced power features of this product require use of 120V receptacle power.

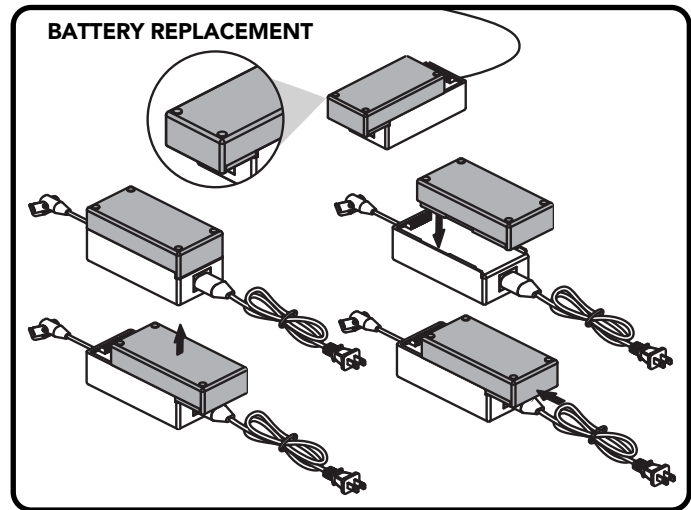

Follow these steps to replace the lithium-ion battery pack batteries:

1. Unplug the external transformer power cord from the electrical outlet.
2. Position the external transformer so that the lithium-ion battery is facing upward.
3. Gently bump with your hand the end of the lithium-ion battery pack to dislodge it from external transformer.
4. Slide the lithium-ion battery until it stops and then lift the lithium-ion battery off of the external transformer.
5. Place the new lithium-ion battery on top of the external transformer with the securement grooves toward the external transformer.
6. Slide the new lithium-ion battery onto the external transformer until it clicks into place.

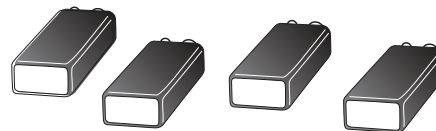
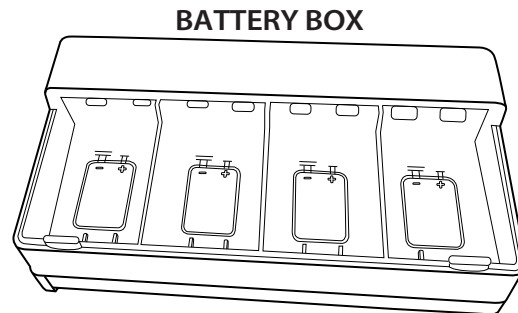

4-9 VOLT BATTERIES
(Not Included)

NOTE: Remove the lithium-ion battery from the battery pack when your chair isn't being used for an extended period of time. The chair will draw power from the battery even when it is not in use.

FCC INSTRUCTION

CAUTION: Changes or modifications not expressly approved by the party responsible for compliance could void the user's authority to operate the equipment.

NOTE: This equipment has been tested and found to comply with the limits for a Class B digital device, pursuant to Part 15 of the FCC Rules. These limits are designed to provide reasonable protection against harmful interference in a residential installation. This equipment generates, uses, and can radiate radio frequency energy and, if not installed and used in accordance with the instructions, may cause harmful interference to radio communications. However, there is no guarantee that interference will not occur in a particular installation. If this equipment does cause harmful interference to radio or television reception, which can be determined by turning the equipment off and on, the user is encouraged to try to correct the interference by one more of the following measures:

- Reorient or relocate the receiving antenna.
- Increase the distance between the equipment and receiver.
- Connect the equipment into an outlet on a circuit different from that to which the receiver is connected.
- Consult the dealer or an experienced radio/TV technician for help.