

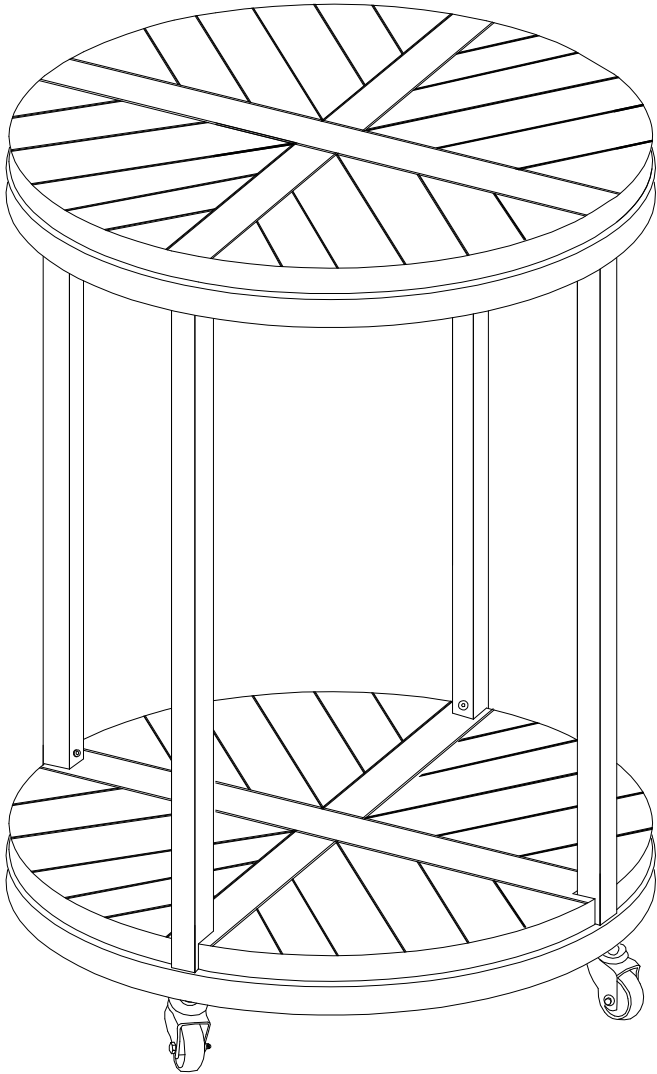





# Industrial Round End Table Assembly Instructions

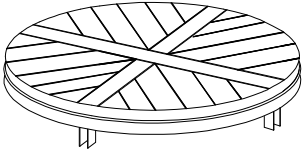
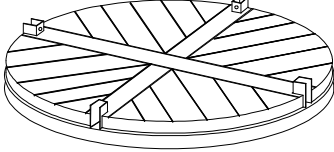

# Industrial Round End Table

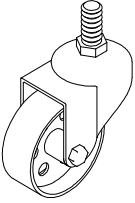
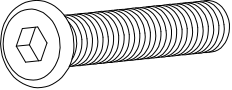
## Parts List

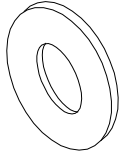
Please check packaging for all parts and hardware before discarding. Unpack and lay parts on clean, padded surface like carpet or a blanket. Check that you have all parts indicated. Call customer service if any hardware is missing. Before beginning assembly, carefully study the diagrams below and sort your hardware according to the pictures. Using the incorrect hardware will cause damage.

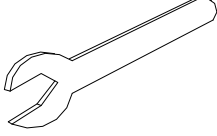
<p><b>A</b> Quantity of 1</p>  <p>Top Panel</p>	<p><b>B</b> Quantity of 1</p>  <p>Shelf Panel</p>	<p><b>C</b> Quantity of 4</p>  <p>Leg</p>
<p><b>D</b> Quantity of 4</p>  <p>Caster</p>	<p><b>1</b> Quantity of 8</p>  <p>lot Ø5/16"*1"L</p>	<p><b>2</b> Quantity of 8</p>  <p>Spring Washer</p>
<p><b>3</b> Quantity of 8</p>  <p>Flat Washer</p>	<p><b>4</b> Quantity of 1</p>  <p>Allen Wrench</p>	<p><b>5</b> Quantity of 1</p>  <p>Wrench</p>

**Care and Cleaning Instructions:**

Before using, wipe with a clean, dry cloth. Avoid rubbing or scratching the surface with rough or abrasive objects.

For replacement parts or questions, please call Customer Service.

**Assembly Tool Required:**

**None**

# Industrial Round End Table Assembly Instructions

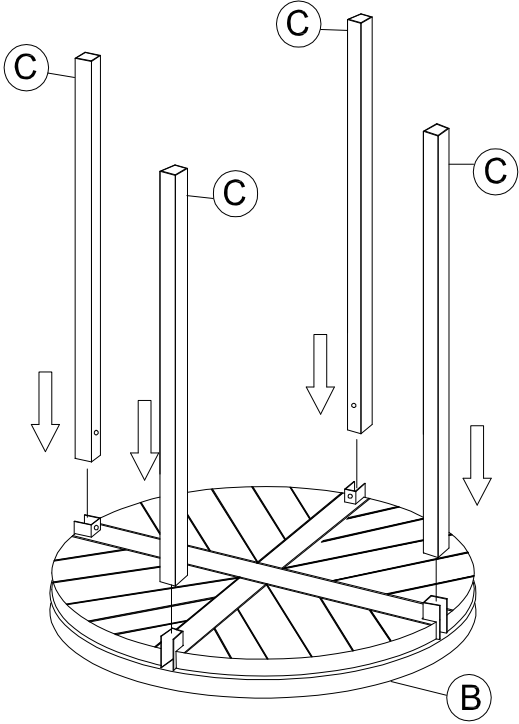

Insert Legs (C) into Shelf Panel (B).

Figure 1

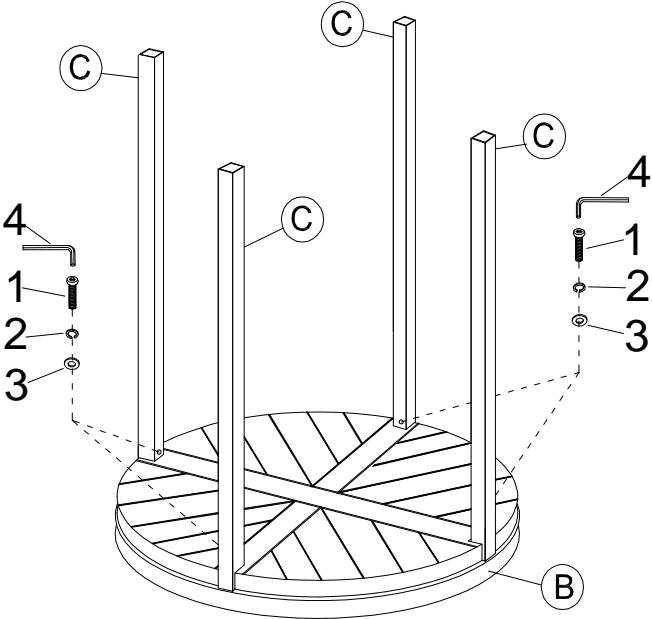

Insert Bolts (1) through Spring Washers (2) and Flat Washers (3) into pre-drilled holes on Legs (C).

Tighten using Allen Wrench (4).

Figure 2

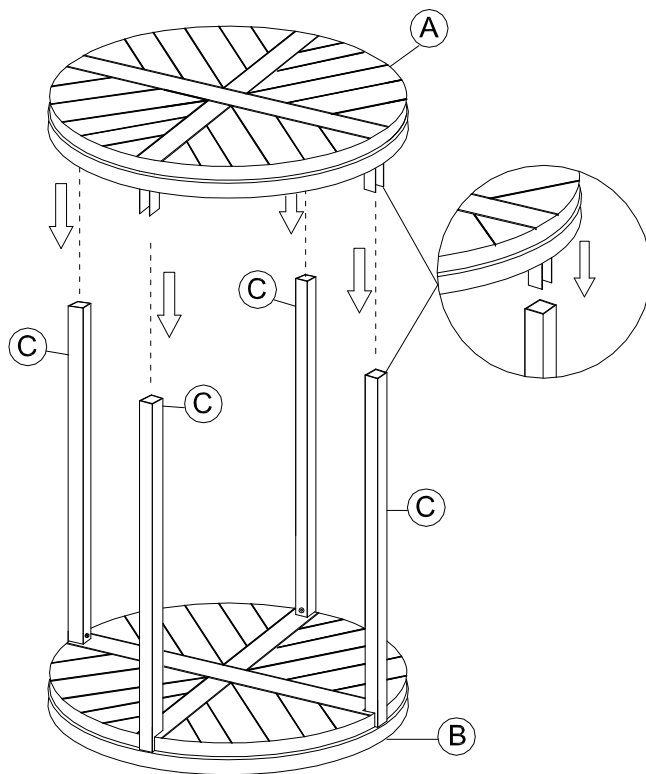

Insert Top Panel **(A)** into Legs **(C)**.

Figure 3

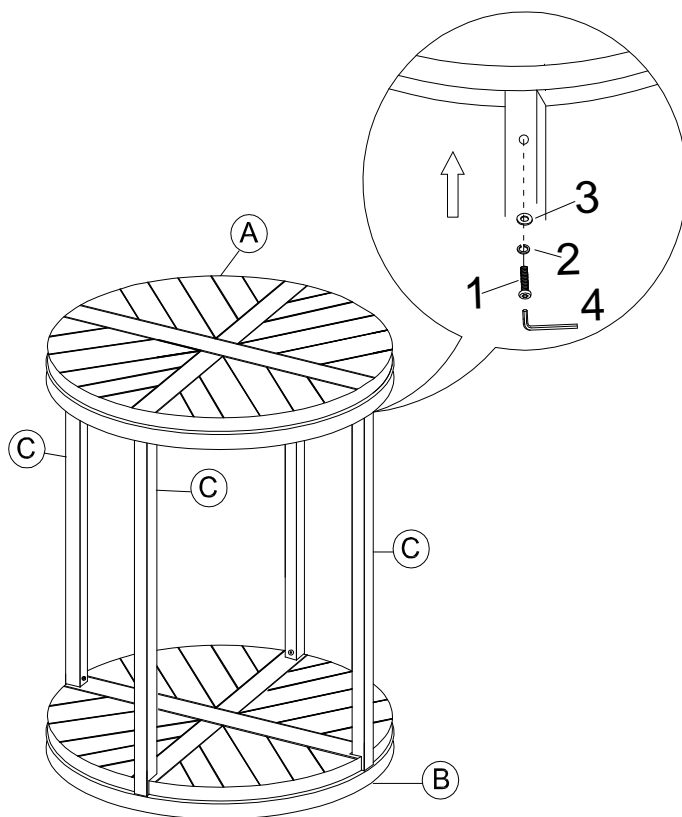

Insert Bolts **(1)** through Spring Washers **(2)** and Flat Washers **(3)** into pre-drilled holes on Legs **(C)**.

Adjust all the Bolts **(1)** using Allen Wrench **(4)** until all panels meet.

Tighten all Bolts **(1)** using Allen Wrench **(4)**.

Figure 4

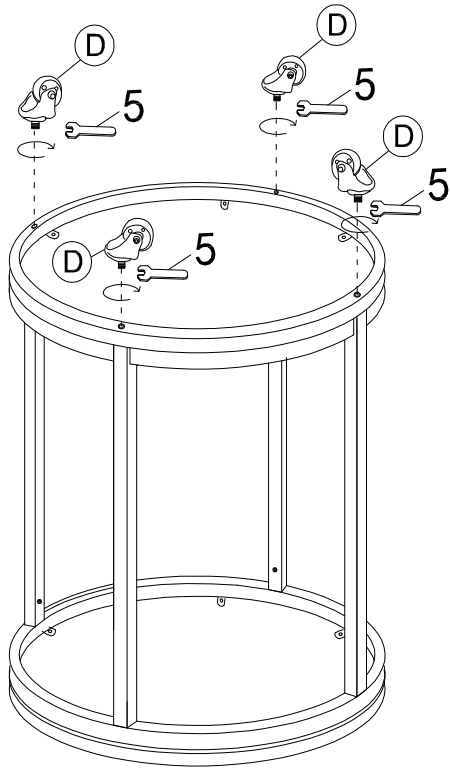

**Figure 5**

Turn over the pre-assembled unit from Figure 4

Attach Casters (**D**) to pre-assembled unit from Figure 4 with Wrench (**5**).

Tighten until secure.

Turn unit over.

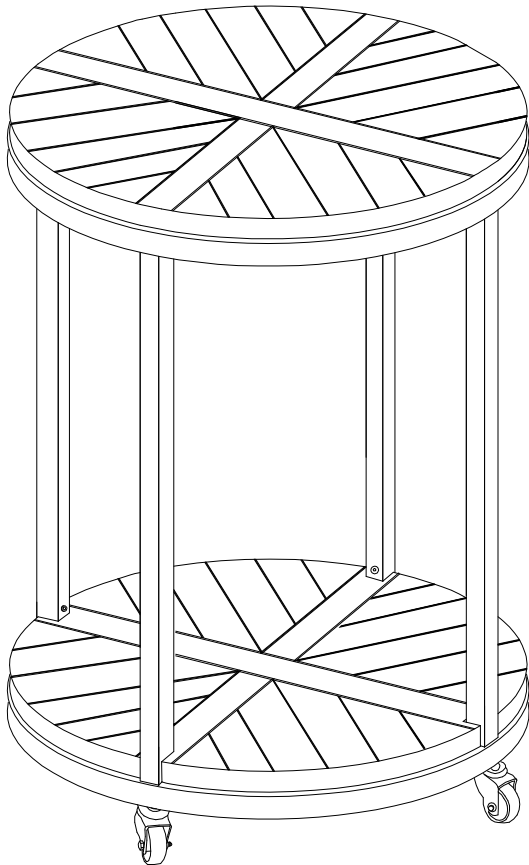

**Figure 6**

Now your Industrial Round End Table is ready to use.

# Parts Replacement Form

## Customer Information

Name \_\_\_\_\_

Address \_\_\_\_\_

City/State/Zip Code \_\_\_\_\_

Phone Number \_\_\_\_\_

Please indicate where you purchased this item: Store/Website/Catalog

\_\_\_\_\_

Please indicate color/size/style number:

\_\_\_\_\_

Style No	Parts Letter	Parts Description	Quantity Needed
_____	_____	_____	_____
_____	_____	_____	_____
_____	_____	_____	_____

Please contact the retailer that you purchased from for returns.