





ASSEMBLY INSTRUCTION

317-745L/M 80" Rectangular Leg Table

HARDWARE LIST

A		Nut	Ø5/16"	8 PCS
B		Lock Washer	Ø5/16"	8 PCS
C		Flat Washer	Ø5/16"*19D	8 PCS
D		Spanner Wrench	12MM	1 PC

PART LIST

1	Table Top	1 PC
2	Leg	4 PCS
3	Center Leg	1 PC
4	Table Leaf	1 PC

IMPORTANT NOTES

- . Place all wooden parts on clean and smooth surface such as rug or carpet to prevent the parts from being scratched.
- . Check to be sure that you have all parts and hardware.
- . Remove all wrapping materials, including staples and packing straps before you start to assemble.
- . Do not tighten all screws and bolts until completely assembled.
- . Keep all hardware out of the reach of children

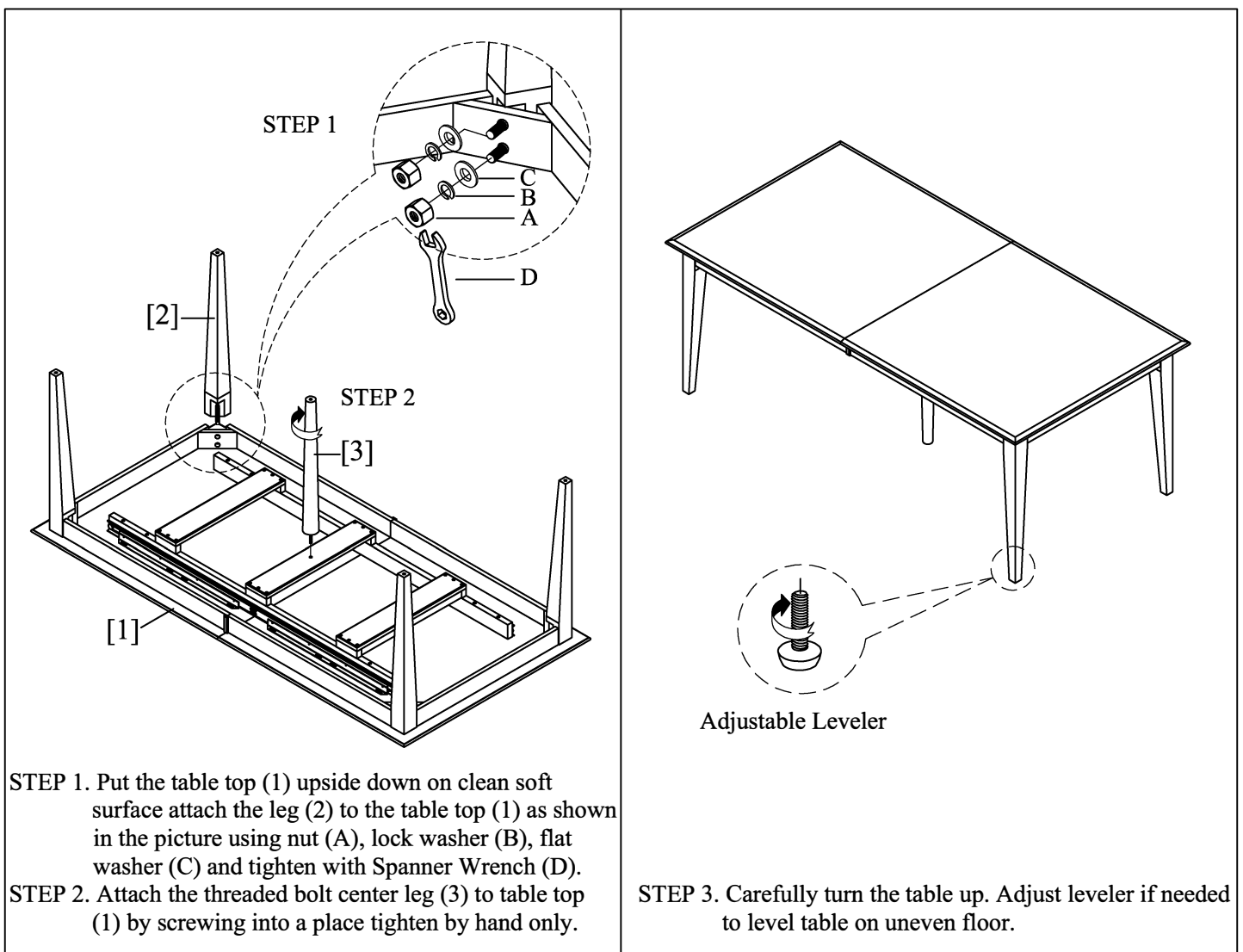

- STEP 1.** Put the table top (1) upside down on clean soft surface attach the leg (2) to the table top (1) as shown in the picture using nut (A), lock washer (B), flat washer (C) and tighten with Spanner Wrench (D).
- STEP 2.** Attach the threaded bolt center leg (3) to table top (1) by screwing into a place tighten by hand only.

- STEP 3.** Carefully turn the table up. Adjust leveler if needed to level table on uneven floor.

MADE IN VIETNAM

ASSEMBLY INSTRUCTION

317-745L/M 80" Rectangular Leg Table

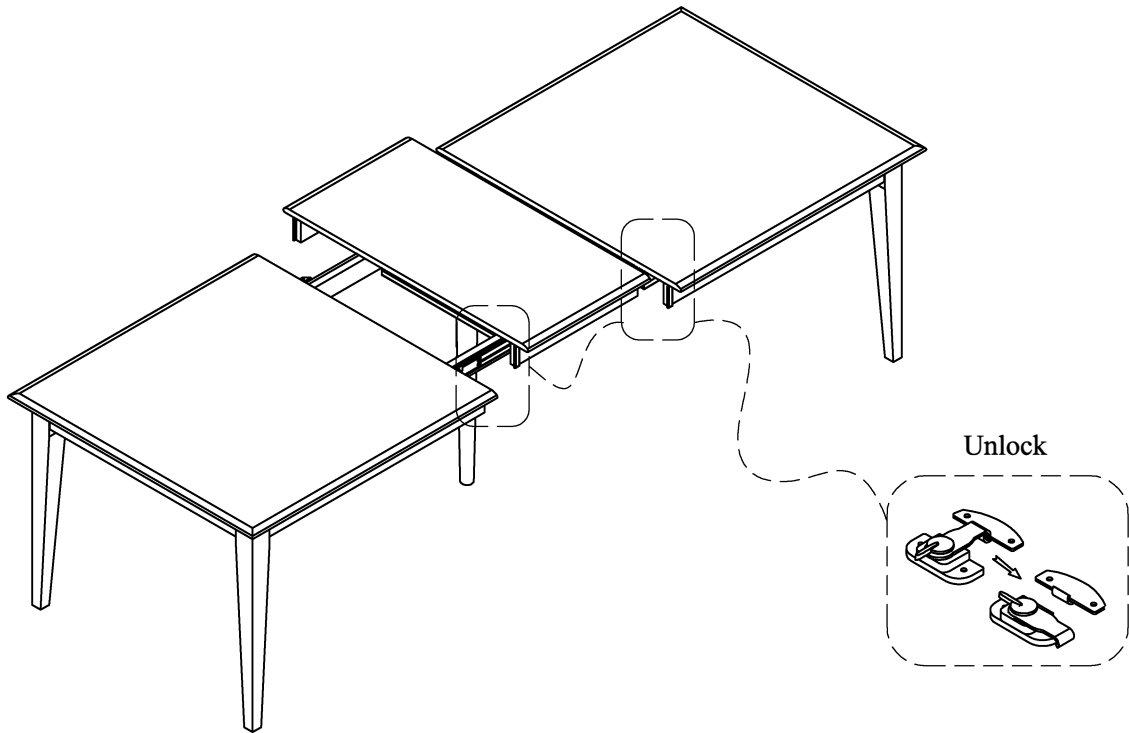

STEP 4. Unlock the table locks and slide open the table halves. Insert one or two the extension table leaf (4) and slide the table halves back together.

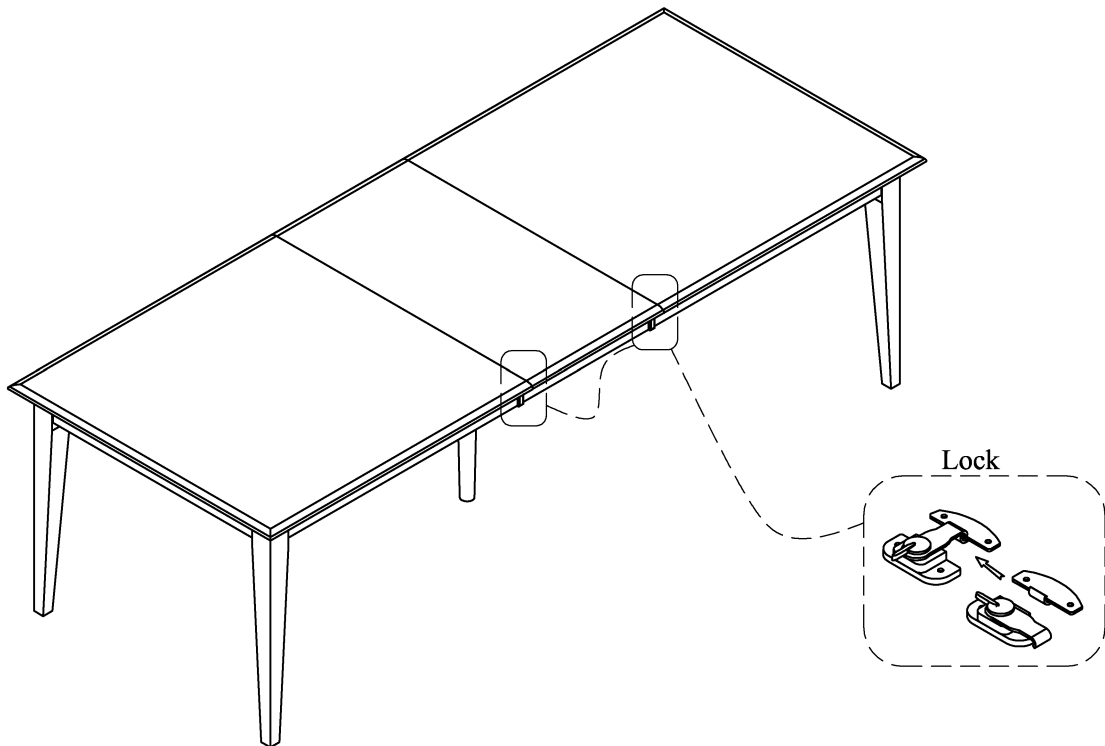

STEP 5. Lock the table locks. Adjust the levelers at the bottom of the feet till the table is even

MADE IN VIETNAM