

# ASSEMBLY INSTRUCTIONS

---

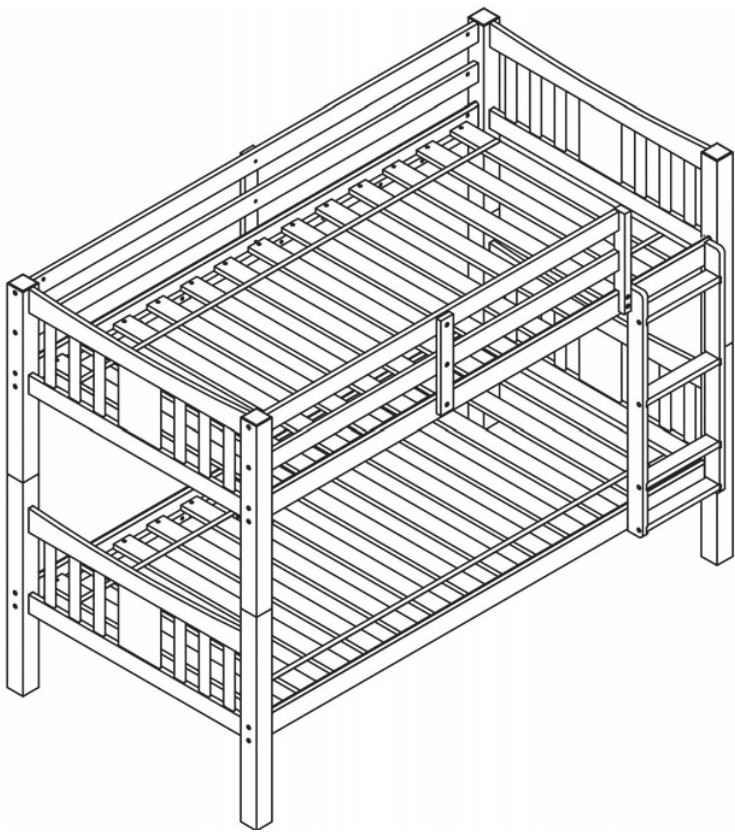

## TOOLS REQUIRED

Allen Wrench

(Included)



Phillips Screwdriver

(Not Included)



4 - People Recommended

## ASSEMBLY RATING



EASY —————> DIFFICULT

The Assembly Rating is a 5-point system showing the level of effort needed to assemble a specific product.

---

# PRE ASSEMBLY INTRODUCTION

We understand building ready-to-assemble furniture can be a challenging experience for some. To help avoid confusion, we have provided some helpful tips that may speed up the process.



## Teamwork

ALWAYS have at least two people to help with transporting and assembling the product to avoid potential injury and/or damage.



## Suitable Location

Assembling near the area of the intended location is highly recommended.



## Sufficient Space

Make sure you have enough space to move around during the assembly.



## Avoid Scratches

Use cardboard, blankets or a carpeted area while assembling furniture to prevent scratches.



## Flat Surface

Make sure the furniture rests on a flat and level surface with each leg evenly touching the floor.

# ASSEMBLY AND CARE ADVICE



**FAILURE TO FOLLOW THE GUIDELINES BELOW MAY RESULT IN INJURY AND/OR PROPERTY DAMAGE.**



Position each part correctly and insert screws or bolts into their respective holes.

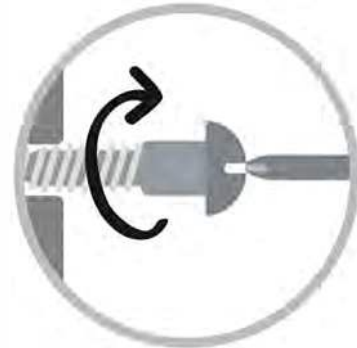

Turn clockwise to tighten and only tighten when step is completed or when instructed to do so.



Use the appropriate hand tools or power tools for assembly. Select steps, such as tightening screws and/or bolts, may require hand tools to avoid causing damage during assembly.



Save the instructions and store any supplied tools for later maintenance.



After two weeks, check and tighten any loose hardware and repeat again every six months thereafter.

**IT IS THE USER'S RESPONSIBILITY TO MAINTAIN THE FURNITURE. THE HARDWARE MAY LOOSEN OVER TIME AND MAY CAUSE THE FURNITURE TO BE WOBBLY AND UNABLE TO SUPPORT ITS INTENDED WEIGHT CAPACITY. THIS MAY LEAD TO COLLAPSE AND MAY CAUSE SERIOUS INJURY.**

# TWIN/TWIN BUNK BED



• Please keep instructions for future reference.  
 • Check the quantity and irregularity of parts and hardware before you start.

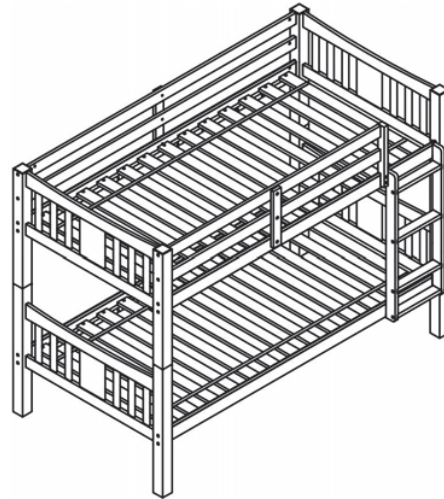

## PARTS

#1 1pc



Upper Headboard

#2 1pc



Upper Footboard

#3 2pcs



Lower Head & Footboard

#4 1pc



Upper Side Rail (Back)

#5 2pcs



Long Guard Rail

#6 2pcs

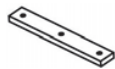

Vertical Guard Rail Support

#7 1pc

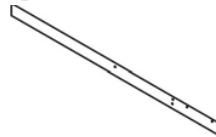

Upper Side Rail (Front)

#8 2pcs



Short Guard Rail

#9 1pc



Front Guard Rail Support

#10 1pc

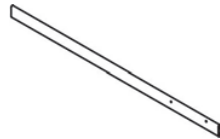

Lower Side Rail ( front )

#11 1pc



Lower Side Rail ( back )

#12 2 set

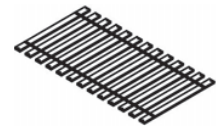

Upper & Lower Slat

#13 1pc



Left Side Rail Ladder

#14 4pcs

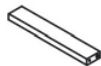

Step Ladder

#15 1pc



Right Side Rail Ladder

## HARDWARE

#A 16pcs



Dowel  $\varnothing 3/8"$  x 1-9/16"

#B 22pcs



Long Bolt  $1/4"$  x 4-3/4"

#C 2pcs



Long Bolt  $1/4"$  x 3-1/16"

#D 4pcs



Short Bolt  $1/4"$  x 1-9/16"

#E 2pcs



Short Bolt  $1/4"$  x 1-3/8"

#F 6pcs



Short Bolt  $1/4"$  x 1-3/16"

#G 24pcs



Barrel Nut  $1/4"$  x 13 (9.5mm)

#H 8pcs



Wood Screw  $1/4"$  x 2-9/16"

#I 4pcs



Metal Pin  $\varnothing 9.5$  x 3-9/16"

#J 52pcs



Wood Screw  $\varnothing 3/16"$  x 35mm

#K 1pc



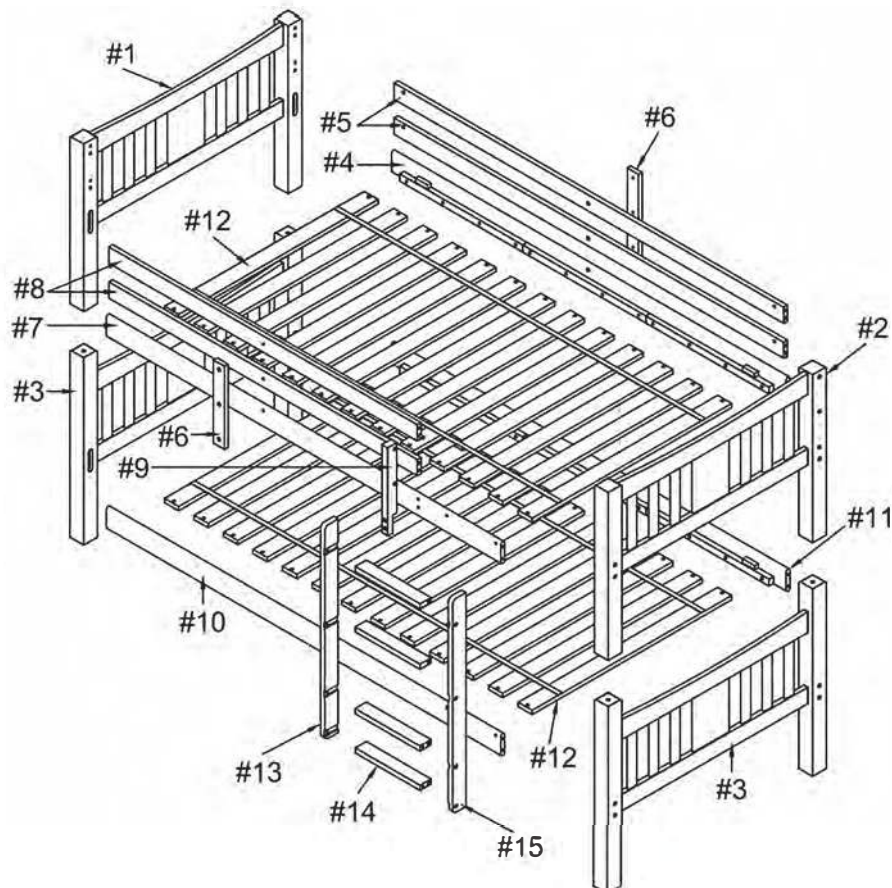

Allen Wrench 4mm

## Exploded View



packed in 2 cases

Carton	Disignation	Part	Hardware
	Upper Headboard	#1 	CM-BK929-VN-1
	Upper Footboard	#2 	 #A x 16pcs
	Lower Head & Footboard	#3 	 #B x 22pcs
	Upper Side Rail (Back)	#4 	 #C x 2pcs
	Long Guard Rail	#5 	 #D x 4pcs
	Vertical Guard Rail Support	#6 	 #E x 2pcs
	Upper Side Rail (Front)	#7 	 #F x 6pcs
	Short Guard Rail	#8 	 #G x 24pcs
	Front Guard Rail Support	#9 	 #H x 8pcs
	Lower Side Rail ( front )	#10 	 #I x 4pcs
	Lower Side Rail ( back )	#11 	 #J x 52pcs
	Upper & Lower Slat	#12 	 #K x 1pc
	Left Side Rail Ladder	#13 	
	Step Ladder	#14 	
	Right Side Rail Ladder	#15 	

# ASSEMBLY INSTRUCTIONS

1

- Part #3 x2pcs
- Part #10 x1pc
- Part #11 x1pc
- Hardware #B x8pcs
- Hardware #G x8pcs

2. Insert 2 barrel nuts (#G) into the pre-drilled holes located on the inner side of each rail end, then 2 long bolts (#B) into the holes along each side of the headboard/ footboard. Lock bolt with nut by using the Allen wrench (#K).

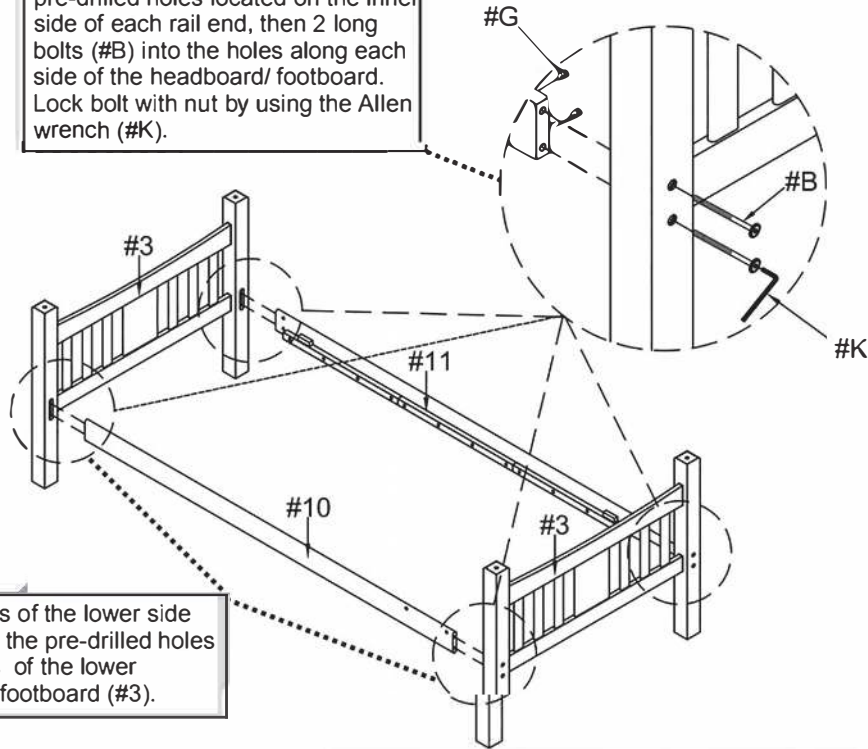

1. Align the ends of the lower side rails (#10/11) to the pre-drilled holes along the sides of the lower headboard and footboard (#3).

2

- Part ● x1pc
- Part #2 x1pc
- Part #4 x1pc
- Part #5 x2pcs
- Part #6 x1pc
- Hardware #A x4pcs
- Hardware #B x8pcs
- Hardware #F x3pcs
- Hardware #G x8pcs

4. Align the vertical guard rail support (#6) to the pre-drilled holes along the center of the rails. Insert 3 short bolts (#F) and secure using the Allen wrench (#K).

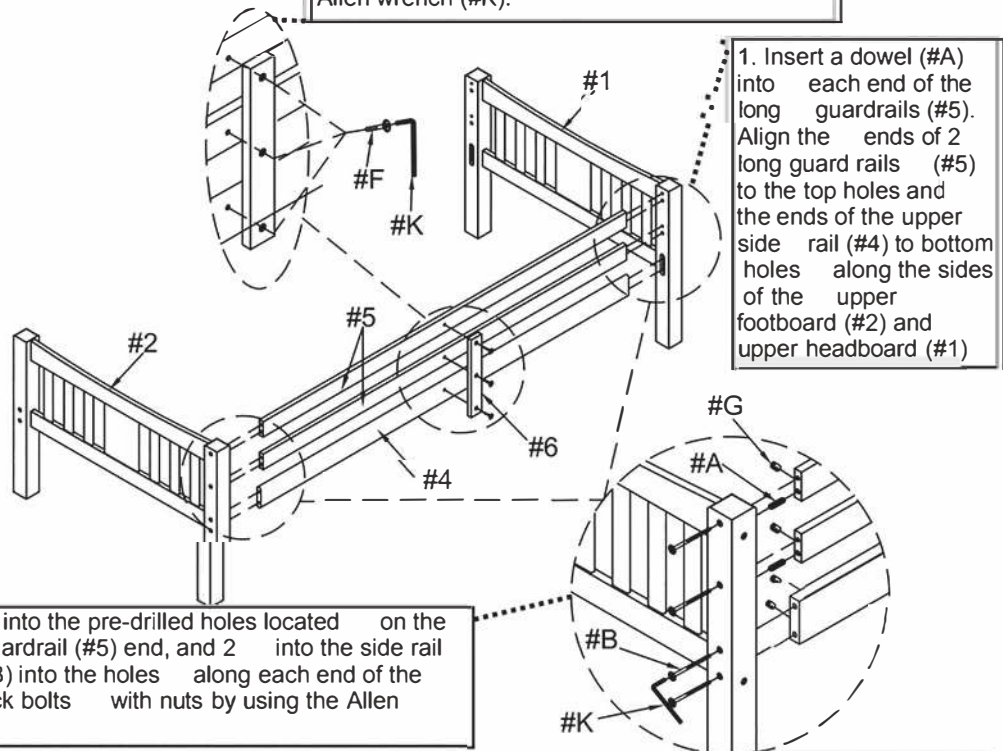

1. Insert a dowel (#A) into each end of the long guardrails (#5). Align the ends of 2 long guardrails (#5) to the top holes and the ends of the upper side rail (#4) to bottom holes along the sides of the upper footboard (#2) and upper headboard (#1).

3. Insert a barrel nut (#G) into the pre-drilled holes located on the inner side of each long guardrail (#5) end, and 2 into the side rail (#4). Then insert bolts (#B) into the holes along each end of the headboard/footboard. Lock bolts with nuts by using the Allen wrench (#K).

# ASSEMBLY INSTRUCTIONS

## 3

- Part #6 x1pc
- Part #7 x1pc
- Part #8 x2pcs
- Part #9 x1pc
- Hardware #A x4pcs
- Hardware #B x6pcs
- Hardware #C x2pcs
- Hardware #E x2pcs
- Hardware #F x3pcs
- Hardware #G x8pcs

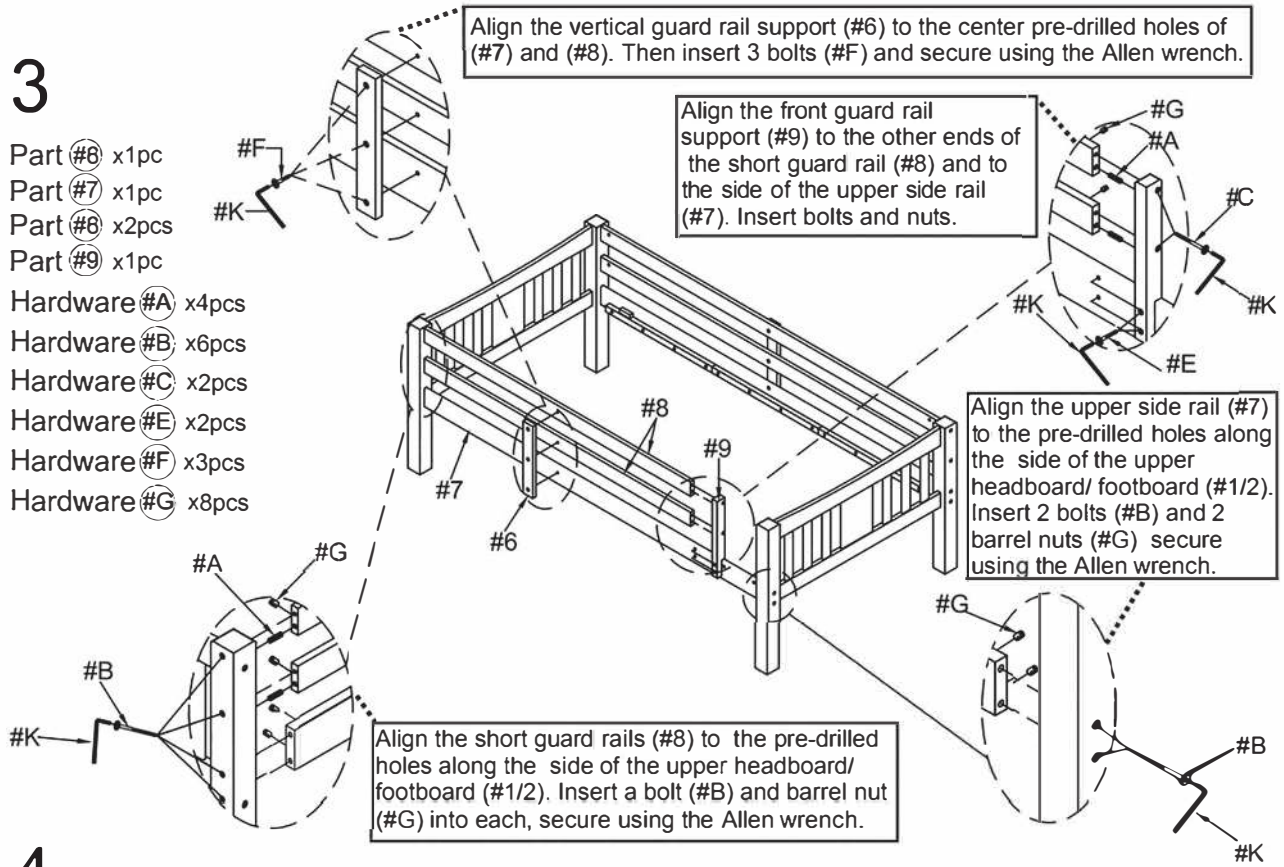

## 4

- Hardware #1 x4pcs

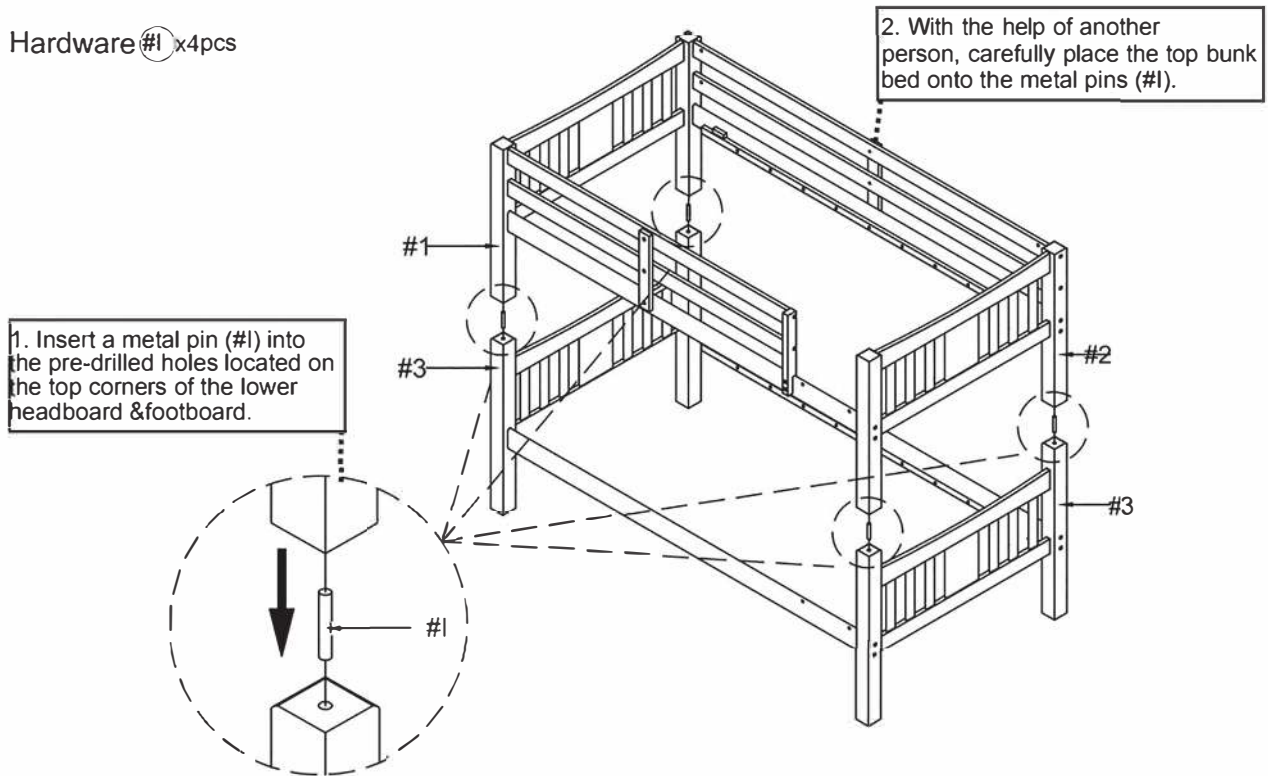

# ASSEMBLY INSTRUCTIONS

## 5

- Part #13 x1pc
- Part #14 x4pcs
- Part #15 x1pc
- Hardware #A x8pcs
- Hardware #H x8pcs

1. Insert a dowel (#A) into the larger pre-drilled holes on each end of the steps (#14). Align those ends of the steps (#14) to the slots along the sides of the left side rail ladder (#13) and right side rail ladder (#15). Then push dowels (#A) into those side rails.

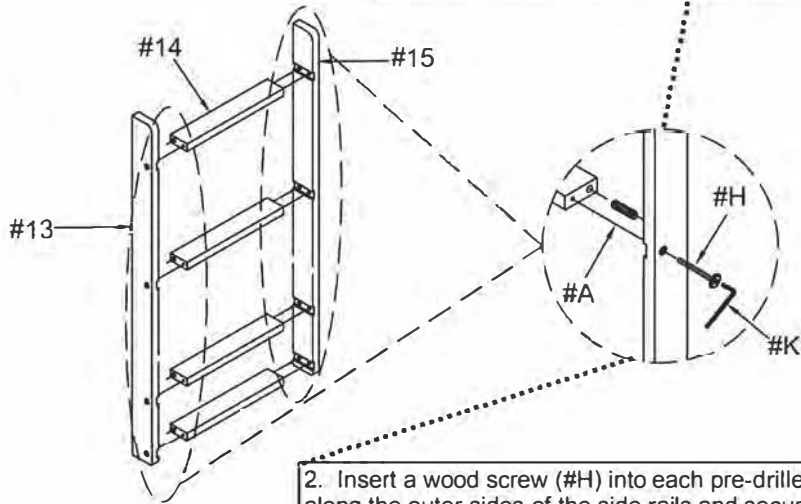

2. Insert a wood screw (#H) into each pre-drilled hole located along the outer sides of the side rails and secure using the Allen wrench (#K).

## 6

- Hardware #D x4pcs

Align the ends of the completed ladder to the upper side rail (#7) and lower side rail (#10). Insert a short bolt (#D) from within the rails and lock using the Allen wrench (#K).

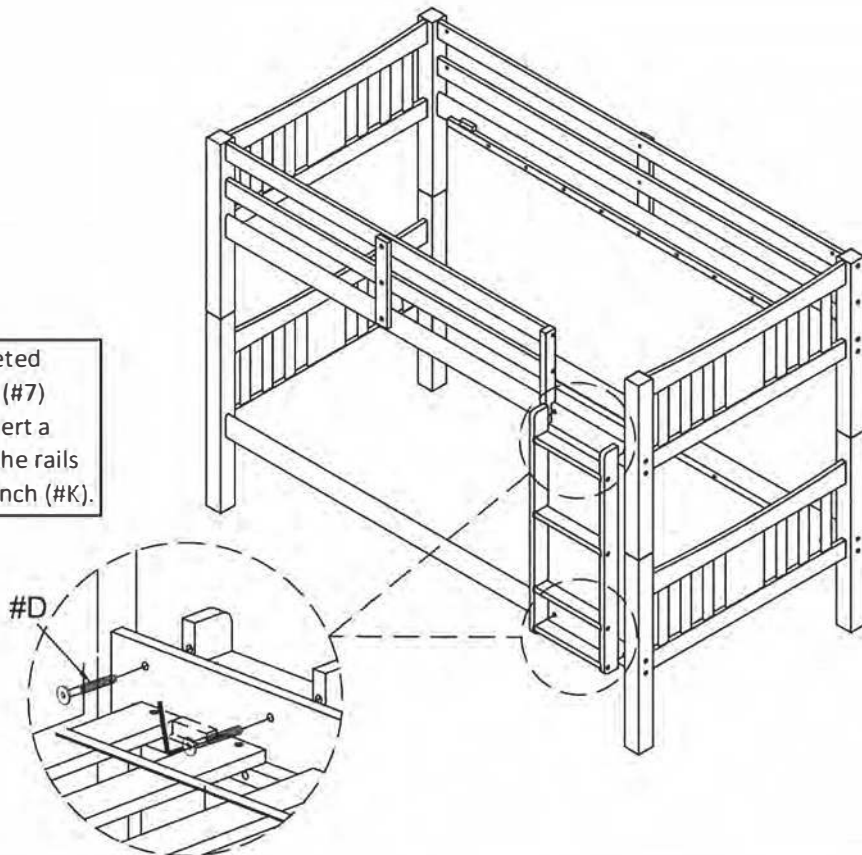

# ASSEMBLY INSTRUCTIONS

## 7

Part #12 x2set  
Hardware ● x52pcs

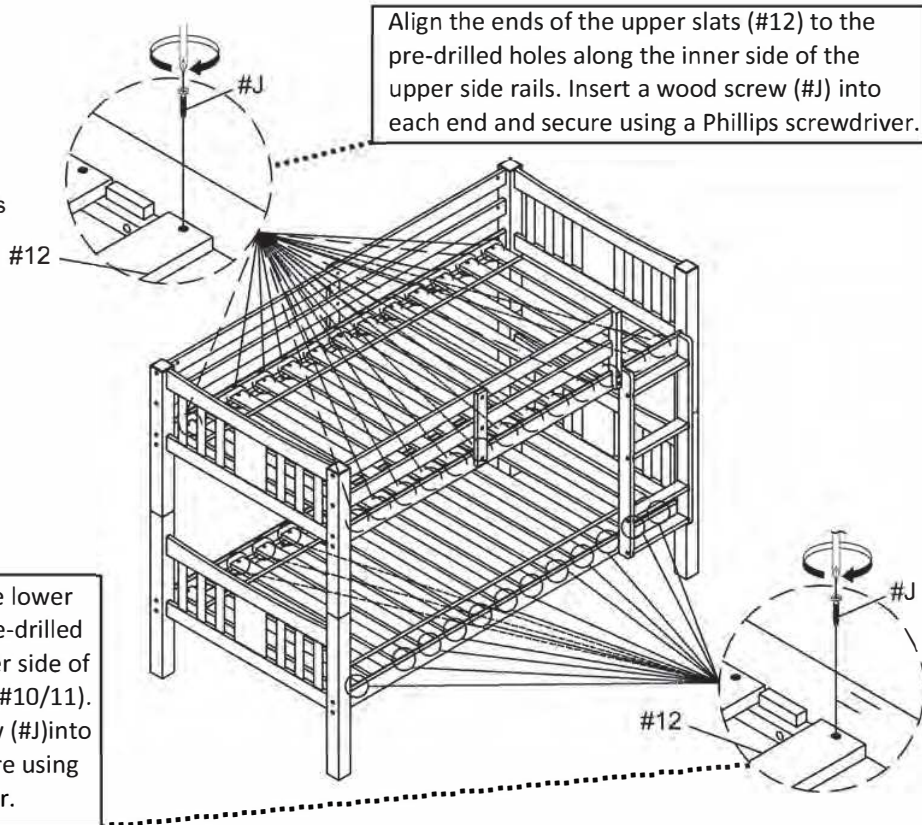

## 8

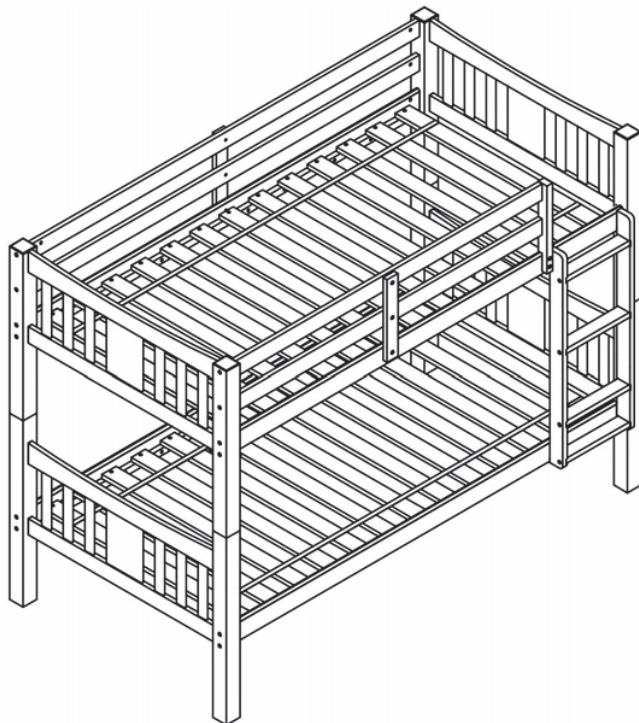

### ASSEMBLY COMPLETED



Please ensure the furniture rests on an even and flat surface. If the product wobbles or feels loose, double-check all bolts and/or screws are properly tightened and secured.



#### Keep this handy!

Please retain this instruction manual and any order-related information for future reference.



#### Lift, don't drag!

To avoid damage to product please always LIFT the product when transporting or adjusting the placement.

## Safety Warnings for Bunk Beds

1. Read and follow the information on the WARNING labels shown on the end structure of the upper bunk and on the carton.
2. Do not remove warning labels from the bed.
3. Keep these instructions for future use.
4. **IMPORTANT:** Must use Bunkie mattress or Bunkie board. The proper sizes for the UPPER/LOWER TWIN-SIZE Bunkie mattress or Bunkie board should be 74"- 75" long and 37 ½" - 38 ½" wide with no more than 6" thickness and for the UPPER/LOWER FULL -SIZE should be 74"-75" long and 53" – 54" wide with no more than 6" thickness.
5. Surface of mattress must be at least 5 inches (127 mm) BELOW the upper edge of the guardrails.
6. The **MAXIMUM** weight capacity for the upper bunk is not to exceed 150 lbs.
7. Do not allow children under 6 years of age to use the upper bunk.
8. Periodically check and ensure that the guardrails, ladder, handle and other components are in their proper position, free from damage, and that all connectors are tightened and secured.
9. **DO NOT** allow horseplay, rough playing, or jumping on the beds and do not allow playing or hiding under the beds.
10. Always use the ladder for entering or leaving the upper bunk.
11. Do not use substitute parts. Contact the manufacturer or dealer for replacement parts.
12. Use of a nightlight may provide added safety precaution for a person using the upper bunk.
13. Always use the guardrails on both sides of the upper bunk.
14. If the bunk bed will be placed next to a wall, the guardrail that runs the full length of the bed should be placed against the wall to prevent entrapment between the bed and the wall.
15. The use of water or sleep flotation mattresses is prohibited.
16. No more than one person is allowed on the upper bunk at all times.
17. Always use the recommended size mattresses or mattress supports, or both, to help prevent the like likelihood of entrapment or falls.

