

2 Wood Door Sideboard

Instruction Manual

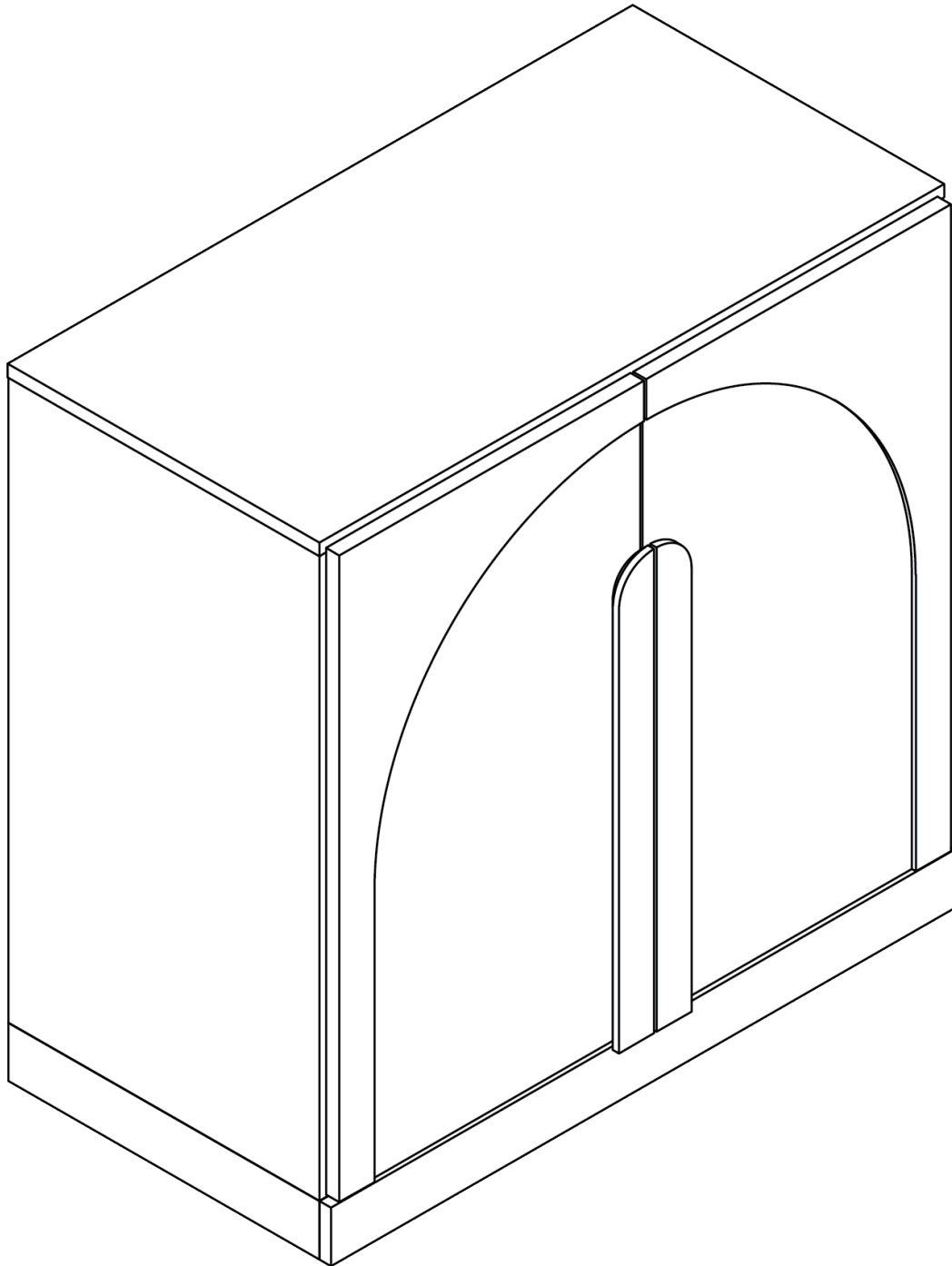

Read Before Assembly

The instruction booklet contains **IMPORTANT** safety information. Please read it in full and keep it for future reference.



WARNING!

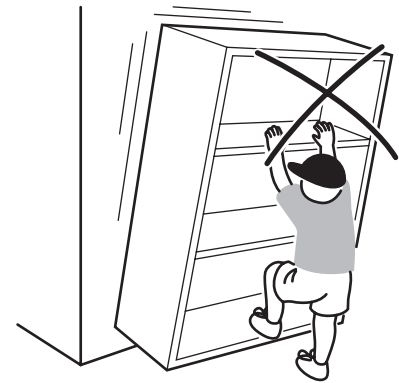
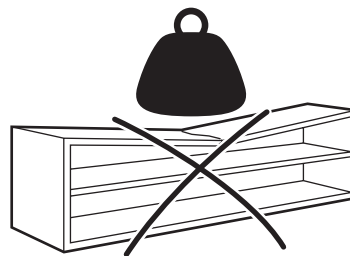
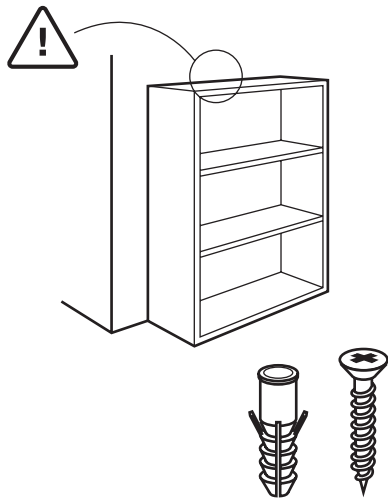

- Serious or fatal crushing injuries may occur if the furniture tip-over. Furniture must permanently affixed to the wall with anti-tipping device(s) in order to prevent the furniture from tipping over.
- Different wall materials requires different type of wall anchors or screws. Use a suitable wall anchors or screws for your specific wall in order to secure the stability and load bearing capacity of the furniture. If you are uncertain about which type of device to use, please contact us or local hardware store and seek professional advice.
- Only place items that is within the recommended size and weight limit of the furniture.
- Items placed onto the furniture must be resting on a support surface without hanging over the edges.
- Climbing on, stepping on, or placing overweighted objects on the product may cause property damage and / or injuries.



CAUTION!

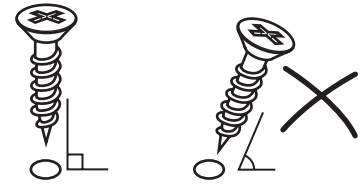
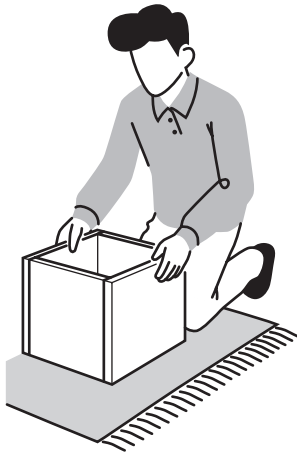

- Assemble the furniture on an empty carton, carpet, or rug to prevent scratches or damage.
- When assembling the furniture, keep pets and children away from the assembly area.
- Ensure the product is fully assembled before use. If you are missing any hardware or parts, do not use it until you have restored the missing parts.
- This furniture requires 2 people for assembly.
- Lay out all components and hardware separately on a flat surface and make sure that no parts are missing or damaged before assembly. Do not destroy or discard any packaging until you are certain that you have all the necessary parts for assembly.
- There are small components used in the construction of the furnitures. Loose items, plastic bags, and packaging films should be kept away from pets or children to avoid choking hazard or suffocations.
- Read this instruction manual prior to assembly and familiarize yourself with the various steps.
- Install all hardware perpendicular to the opening unless otherwise specified.
- Hand tight all hardware and careful not to over-tighten to avoid damaging the product.

Assembly Symbols



- Follow sequential order.



- Build specified number of parts.



- Flip part as indicated.



- Rotate part as indicated.



- Choose your own assembly options.



- Pay attention to the part orientation.



- Leave bolts or screws partially tighten.



- Fully tighten bolts or screws.



- Level the furniture on the ground.



Estimated Time for Assembly

90 mins



Weight Capacity Limitations are as Follows:

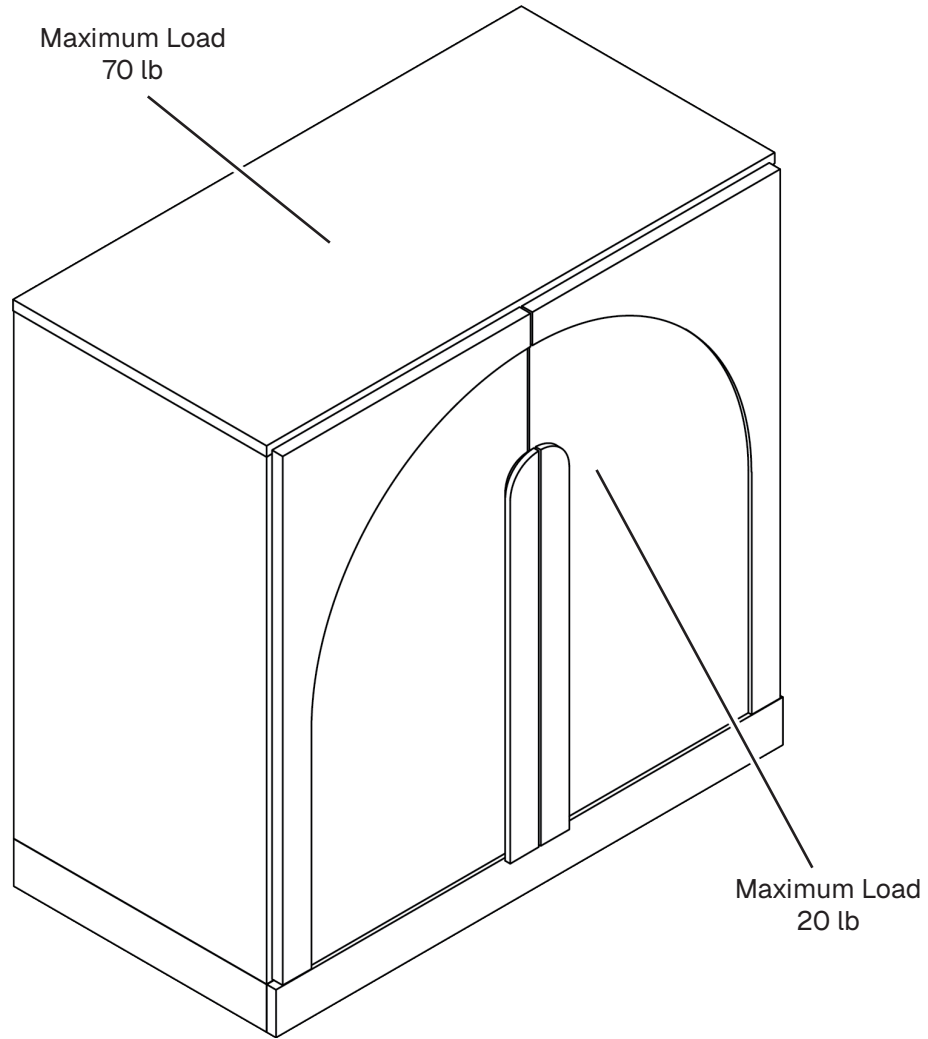

Tools Needed



• Philips Screwdriver

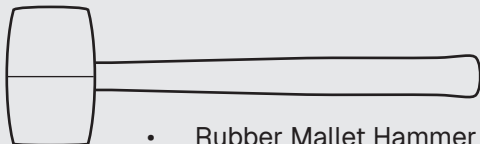

• Rubber Mallet Hammer

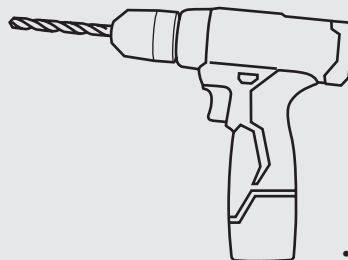

• Electric Drill

Package Contents

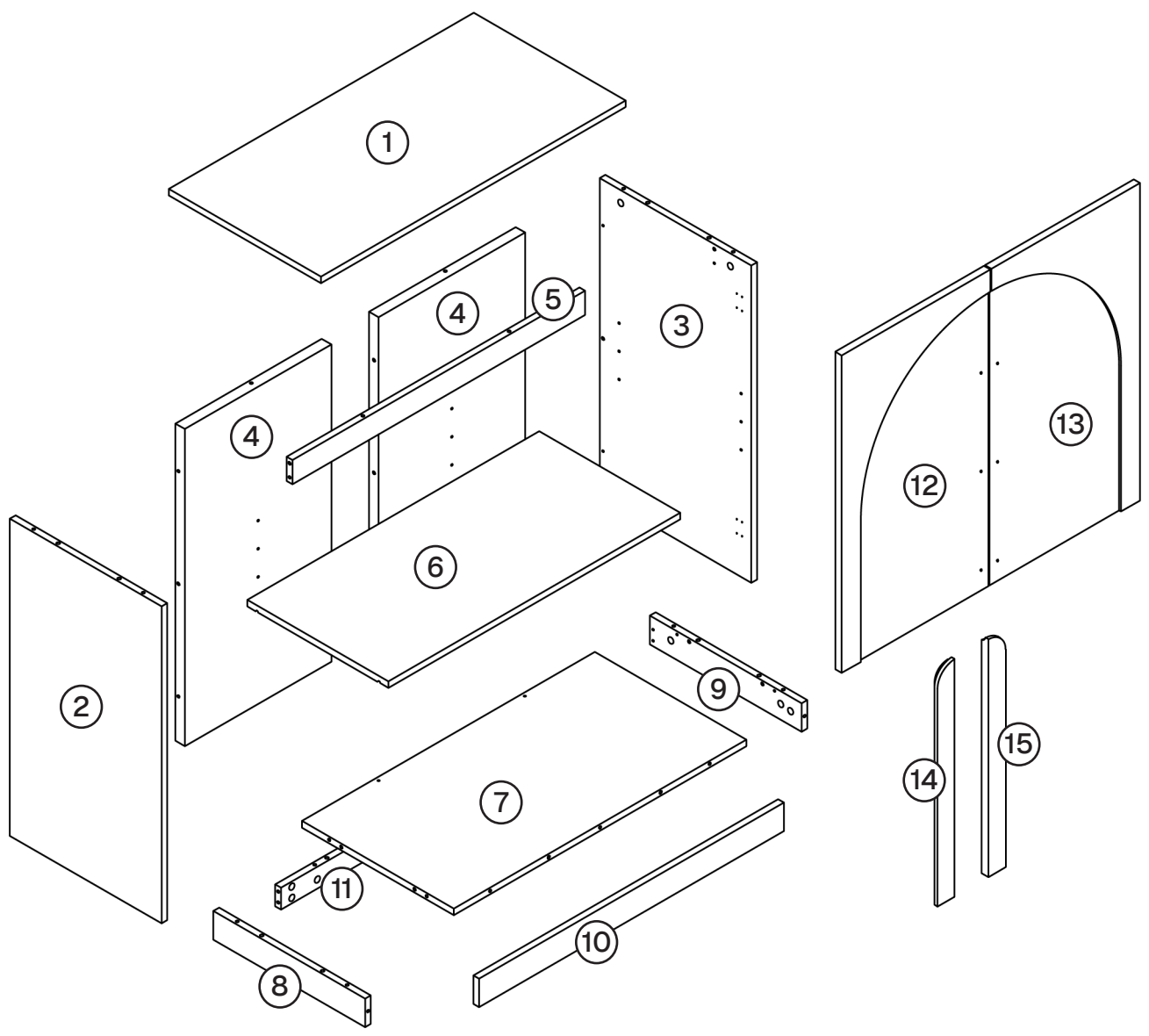

Package Contents

CODE	DESCRIPTION	QTY
1	Top Panel	1
2	Left Lateral Panel	1
3	Right Lateral Panel	1
4	Back Panel	2
5	Crossbar	1
6	Storage Shelf Panel	1
7	Bottom Panel	1
8	Left Base Strip	1
9	Right Base Strip	1
10	Front Base Strip	1
11	Back Base Strip	1
12	Left Cabinet Door	1
13	Right Cabinet Door	1
14	Left Door Handle	1
15	Right Door Handle	1

Package Contents



32x + 3x



36x + 3x

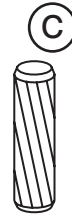

23x + 2x

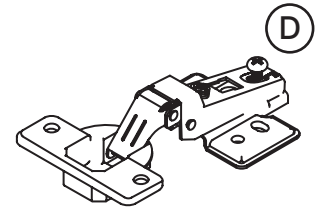

4x



24x + 2x

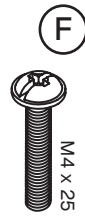

6x + 1x



6x

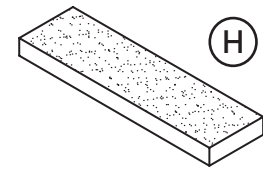

4x

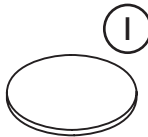

4x



2x

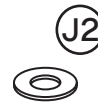

4x

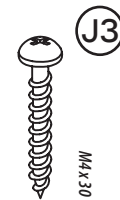

4x

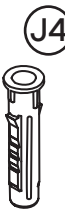

2x



4x + 1x

01 Lateral panels

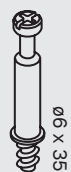

A 6x

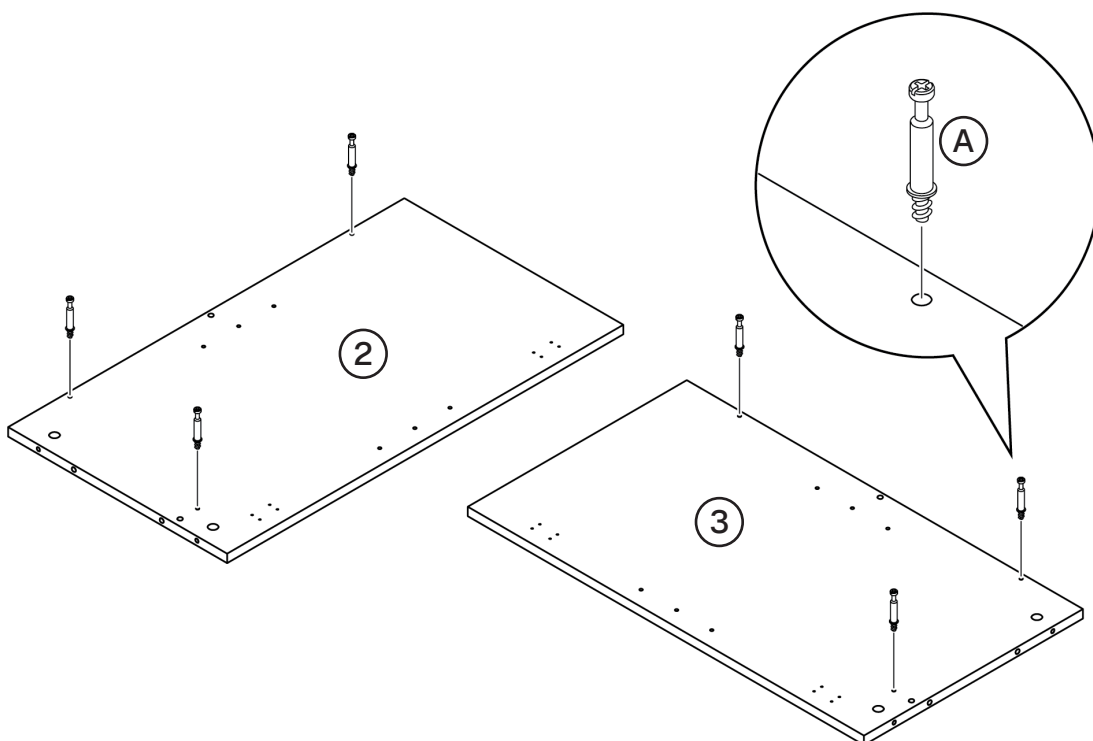

02 Right lateral panel



C 2x

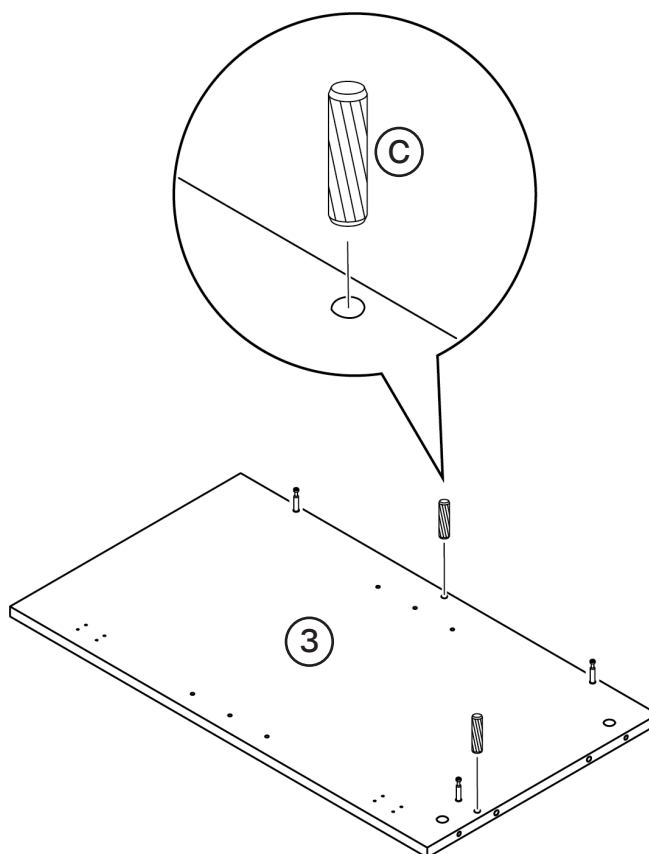

03 Attaching crossbar and back panel



B 3x

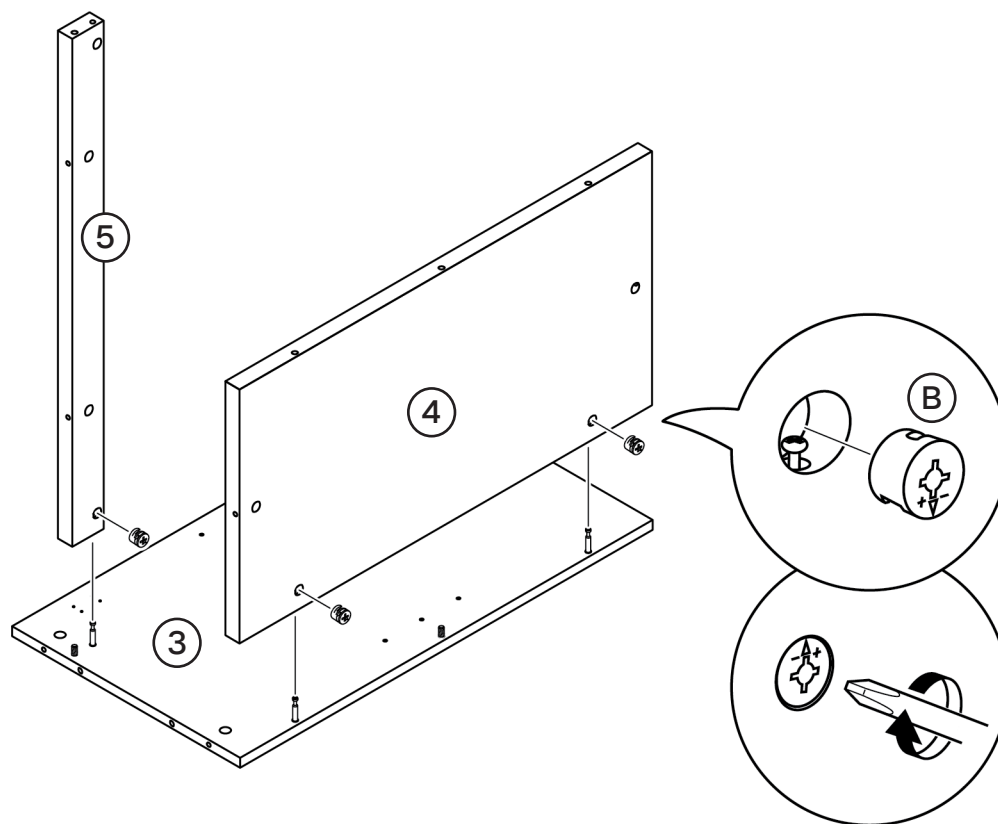

04 Connecting back panels



C 5x

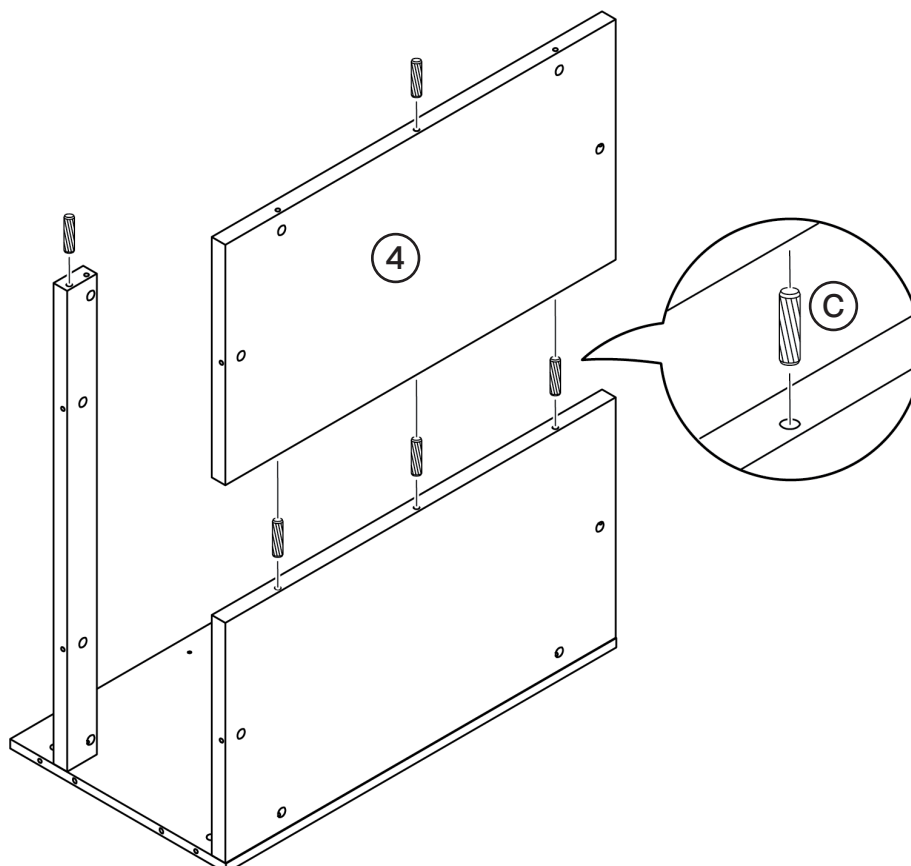

05

Attaching left lateral panel



B 3x

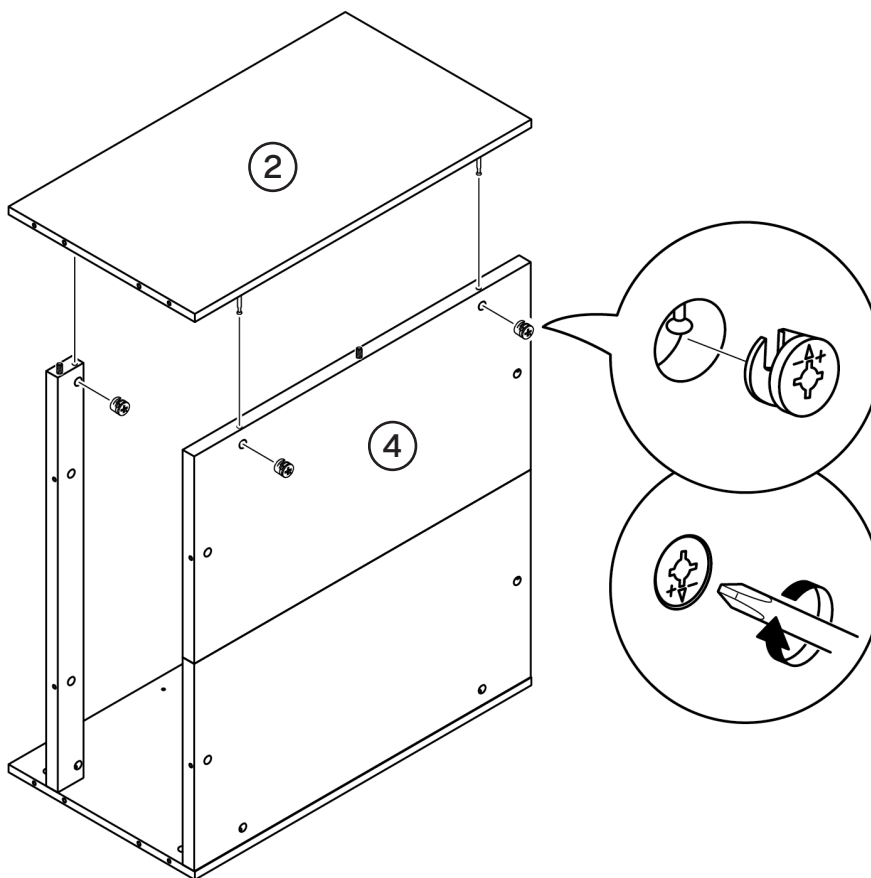

06

Top panel



ø6 x 35

A 8x

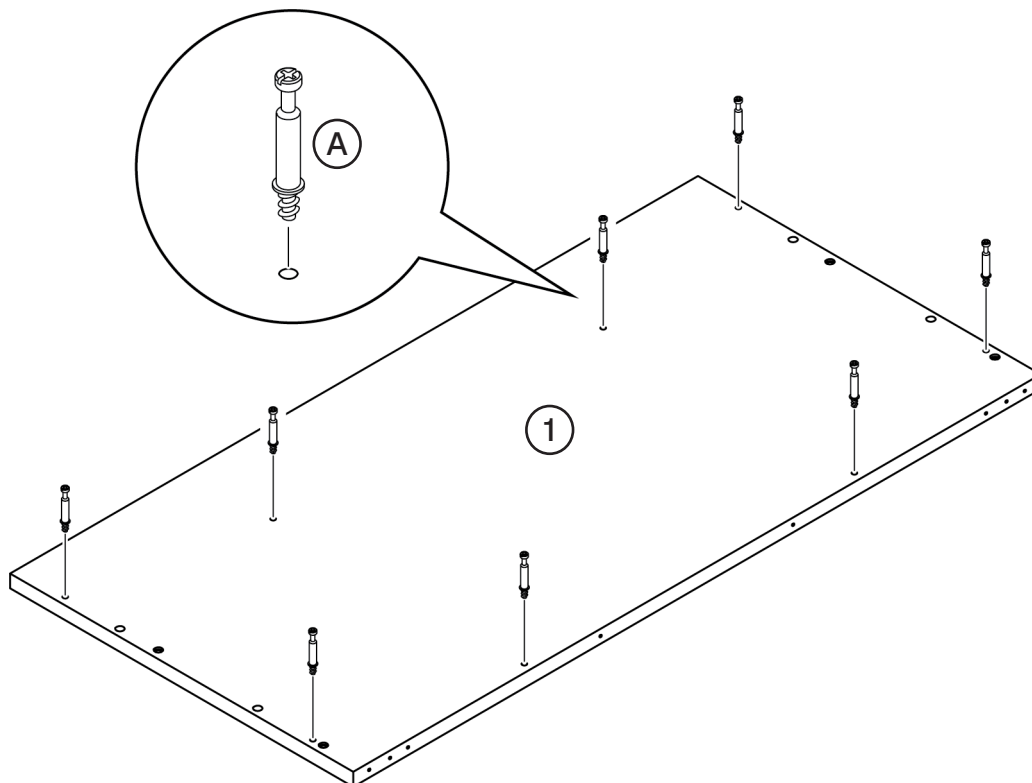

07

Inserting wood dowel to lateral panels



C 4x

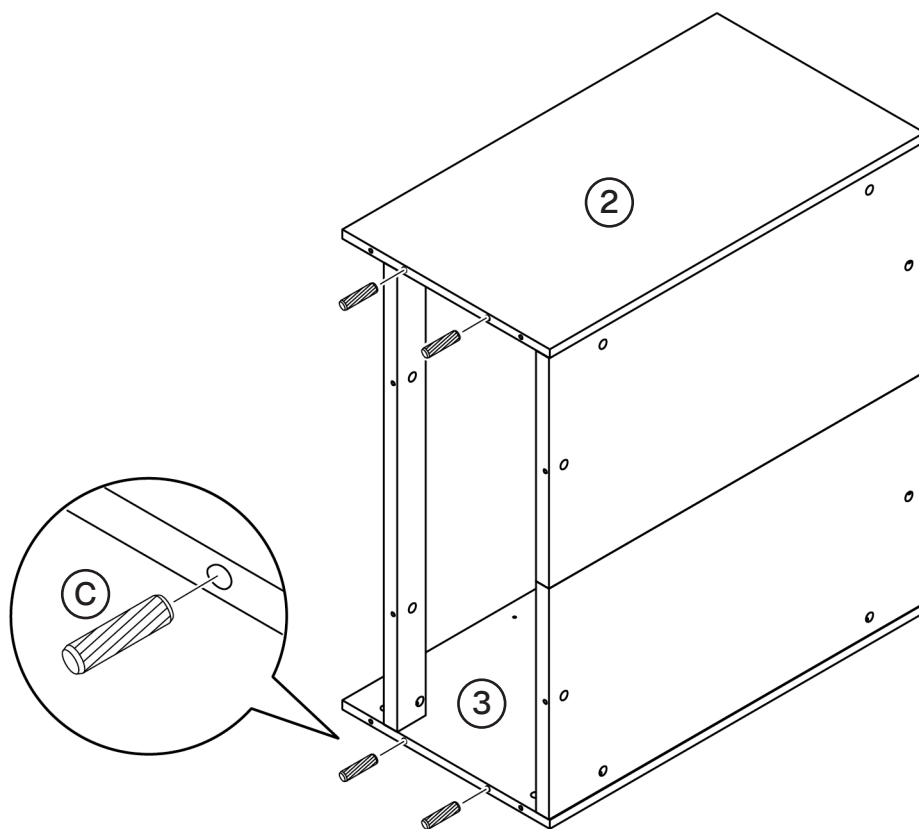

08

Attaching left lateral panel



B 4x



I 4x

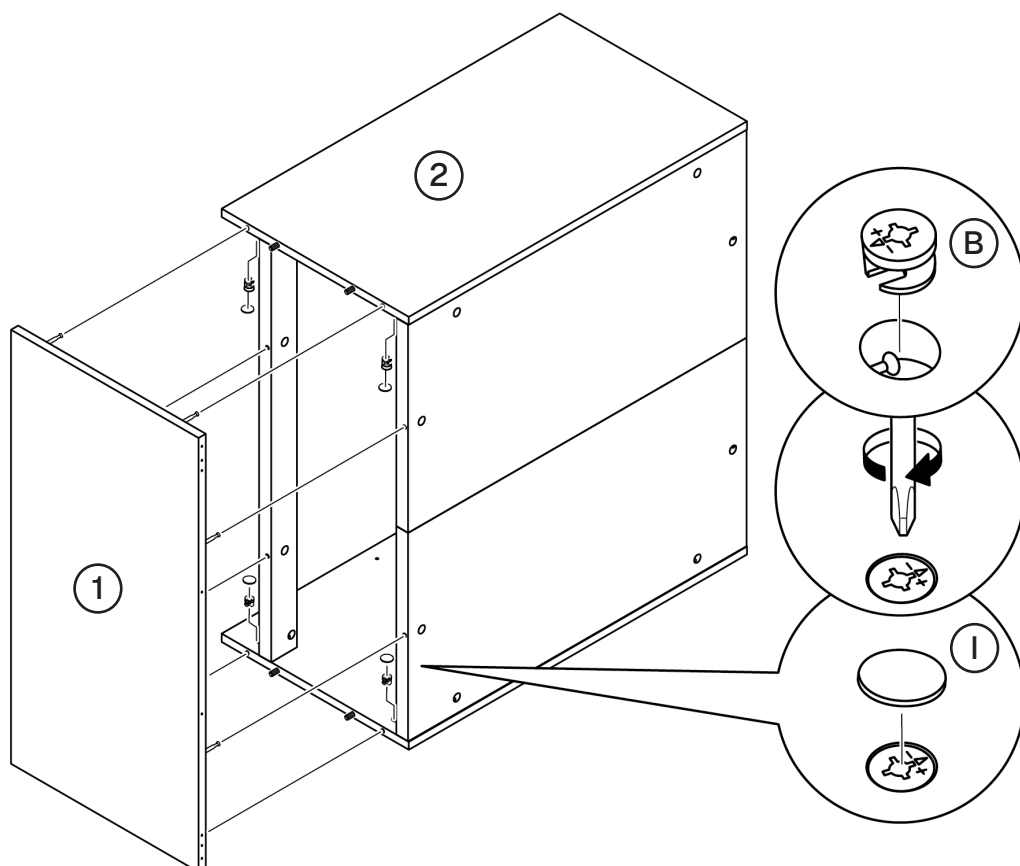

09

Securing crossbar and back panels to top panel



B 4x

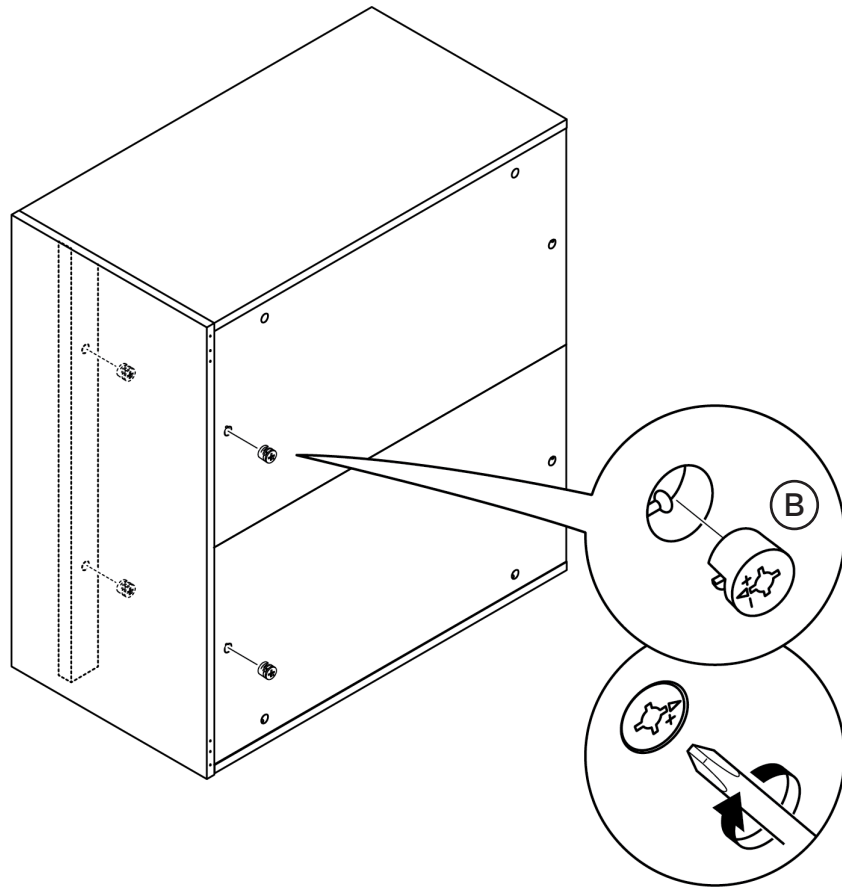

10

Bottom panel

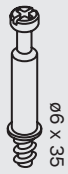

A 3x

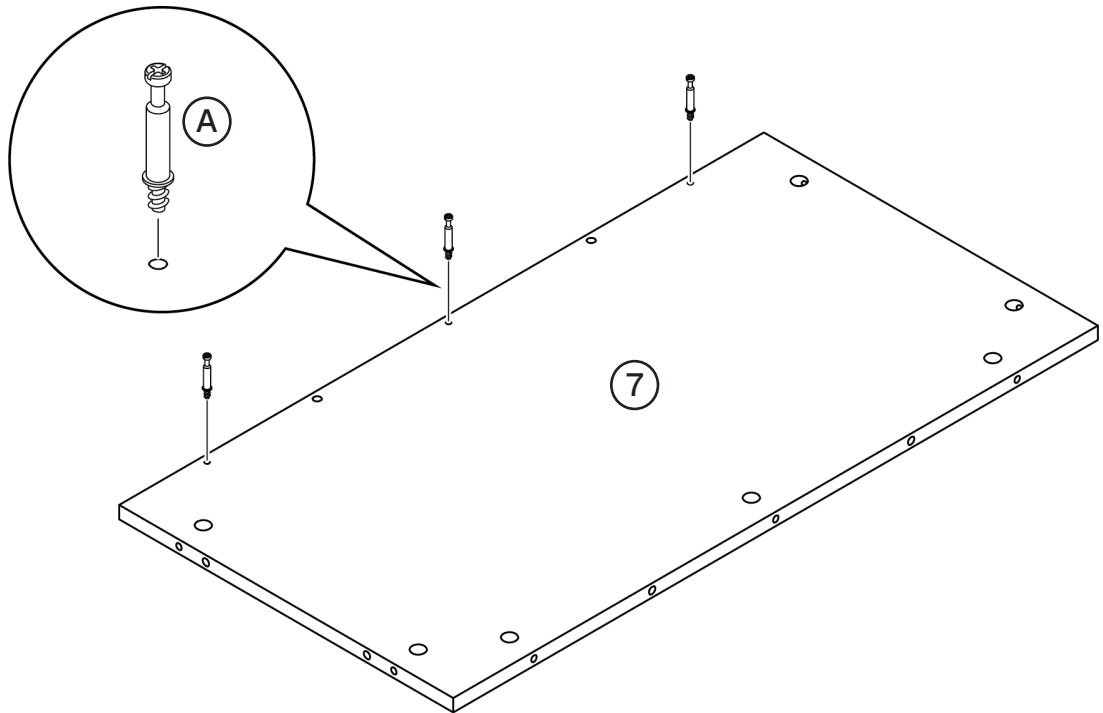

11

Bottom panel



C 8x

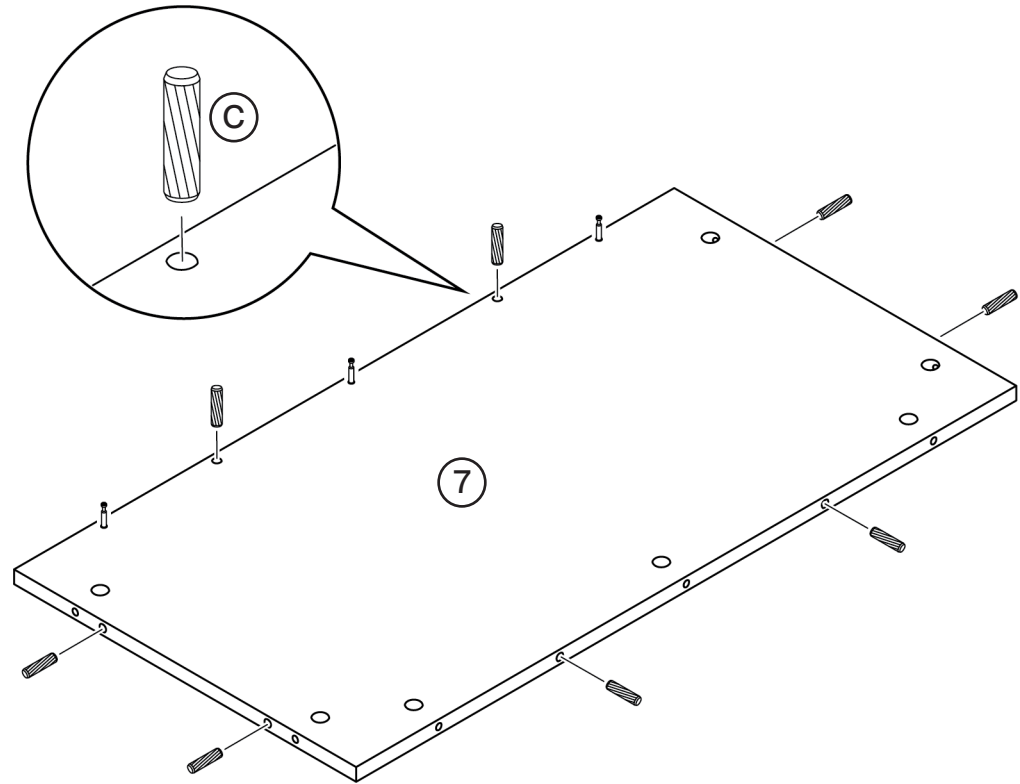

12

Attaching back base strip



B 3x

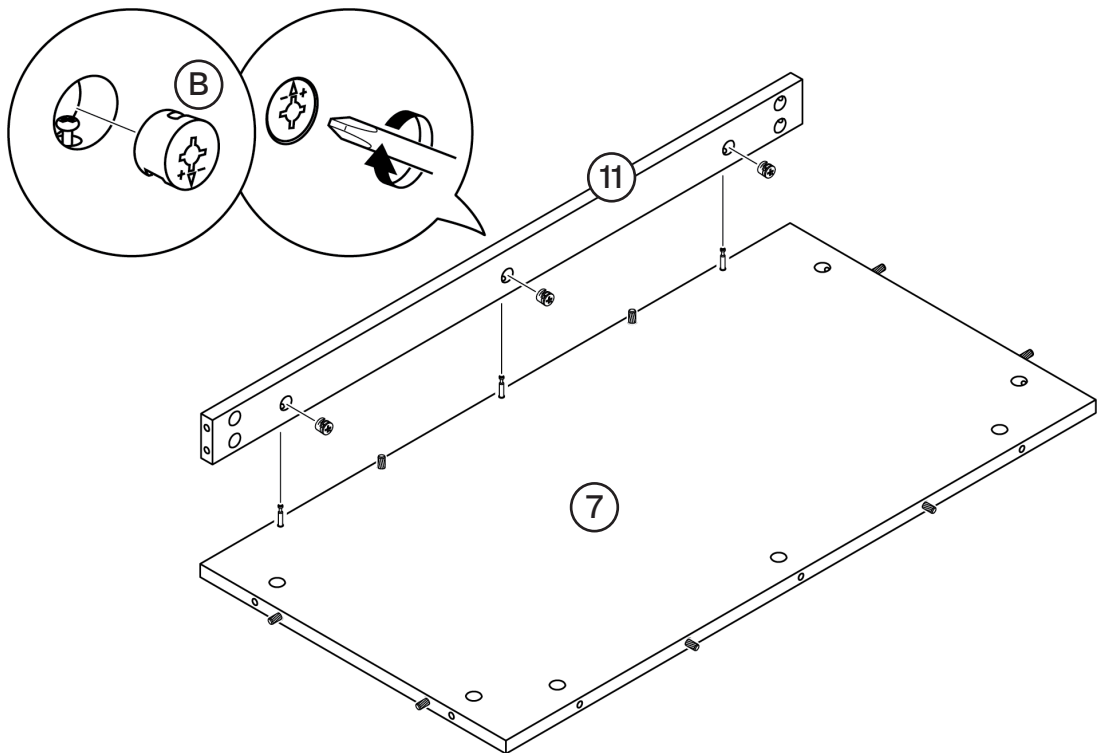

13

Front and side base strips

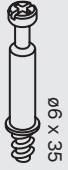

A 13x

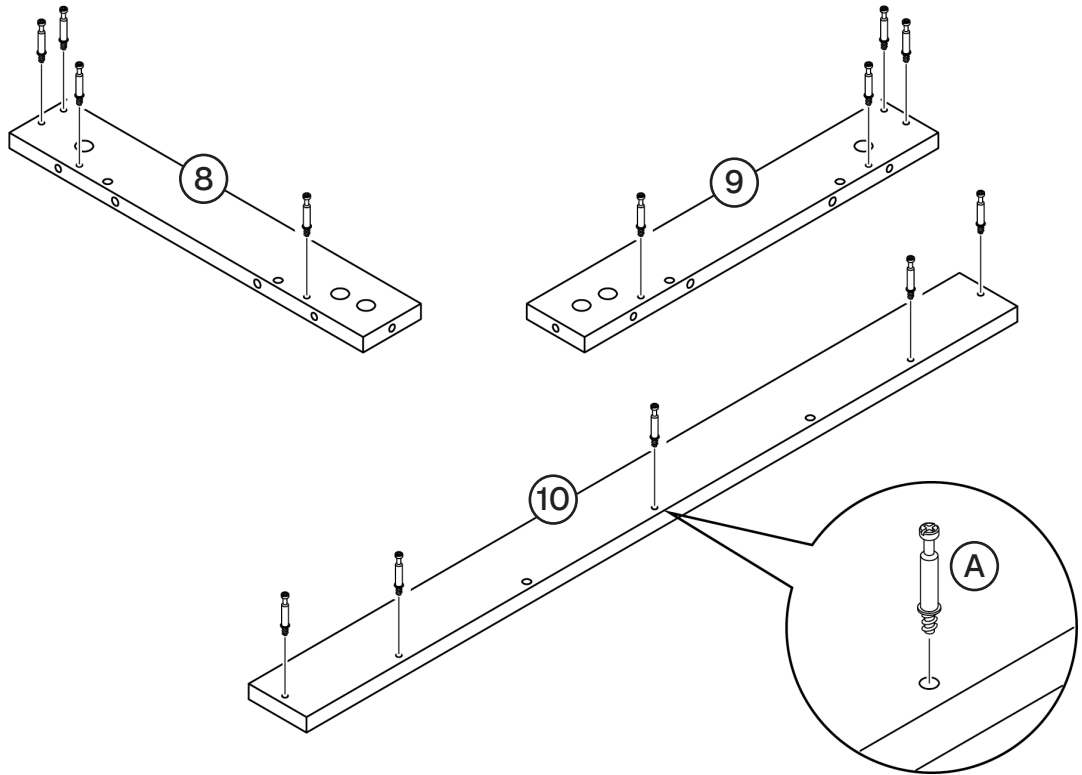

14

Attaching side base strip



B 8x

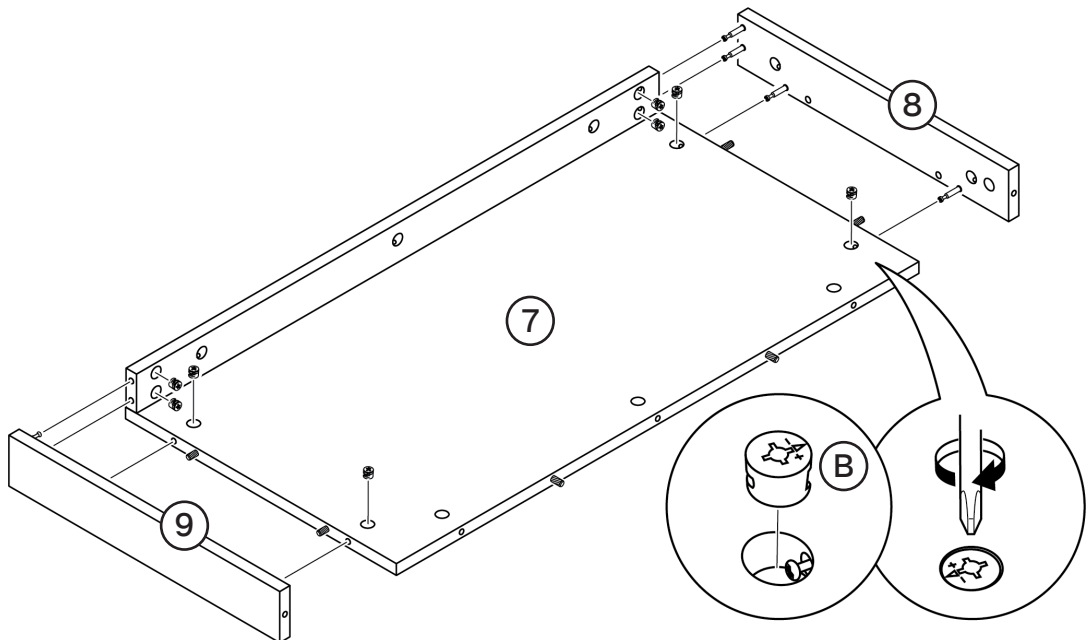

15

Attaching front base strip

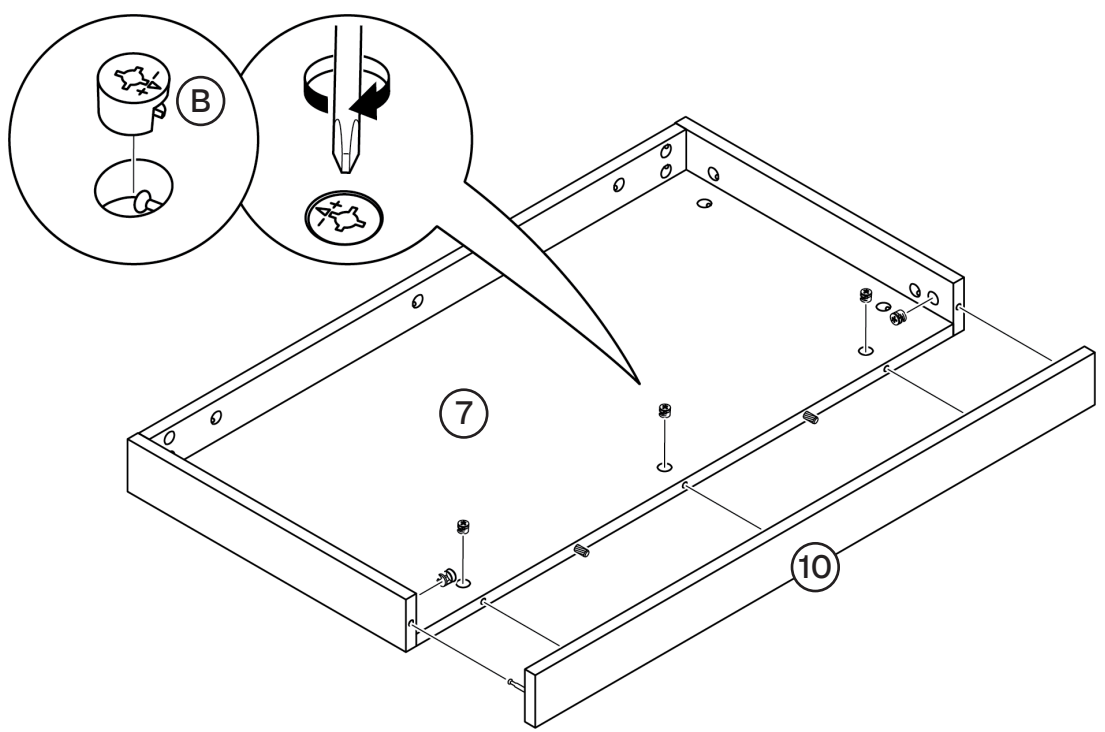

16

Base

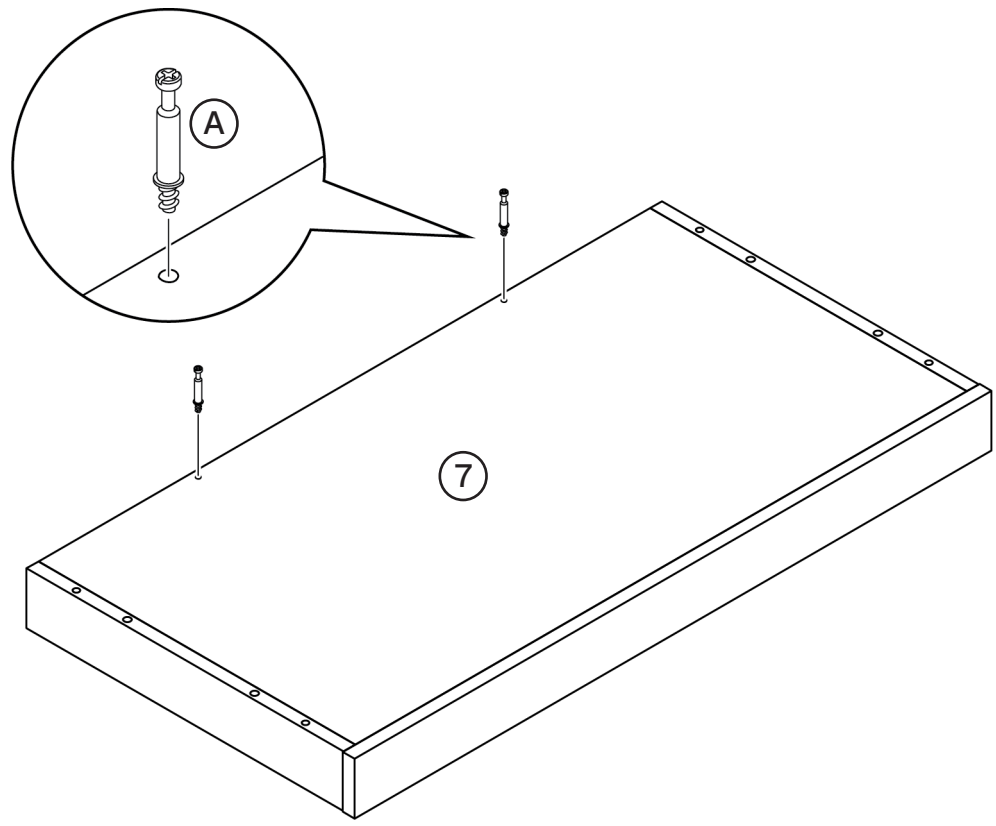
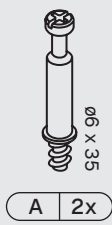

17

Attaching cam bolts to lateral panel



K 4x

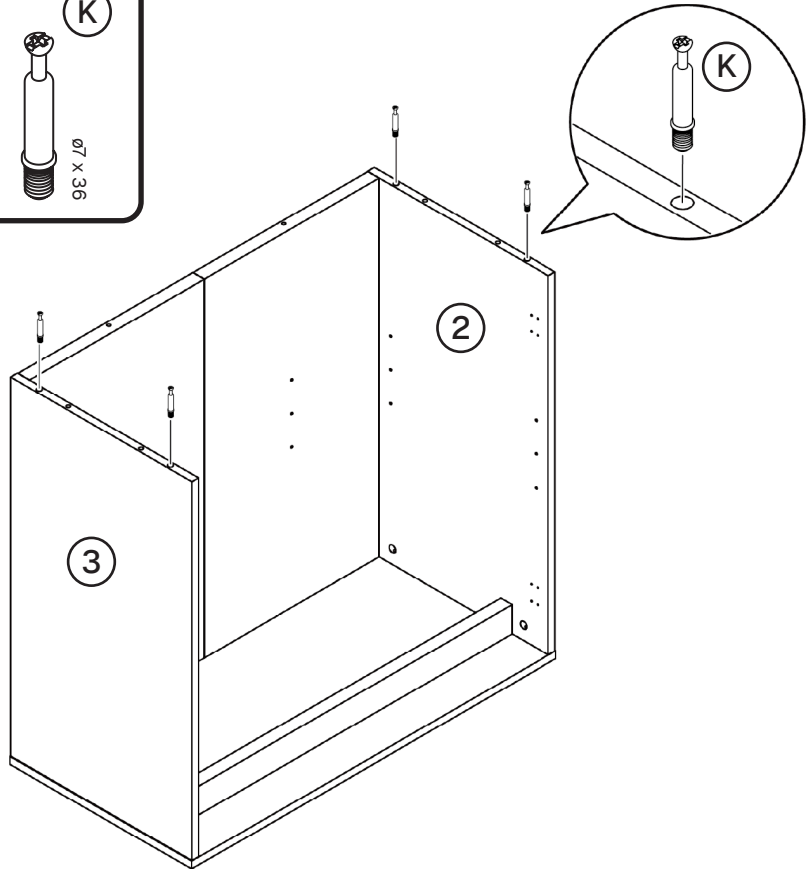
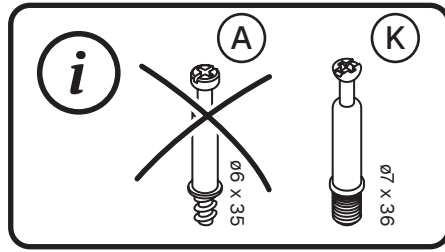

18

Inserting wood dowels to lateral panel



C 4x

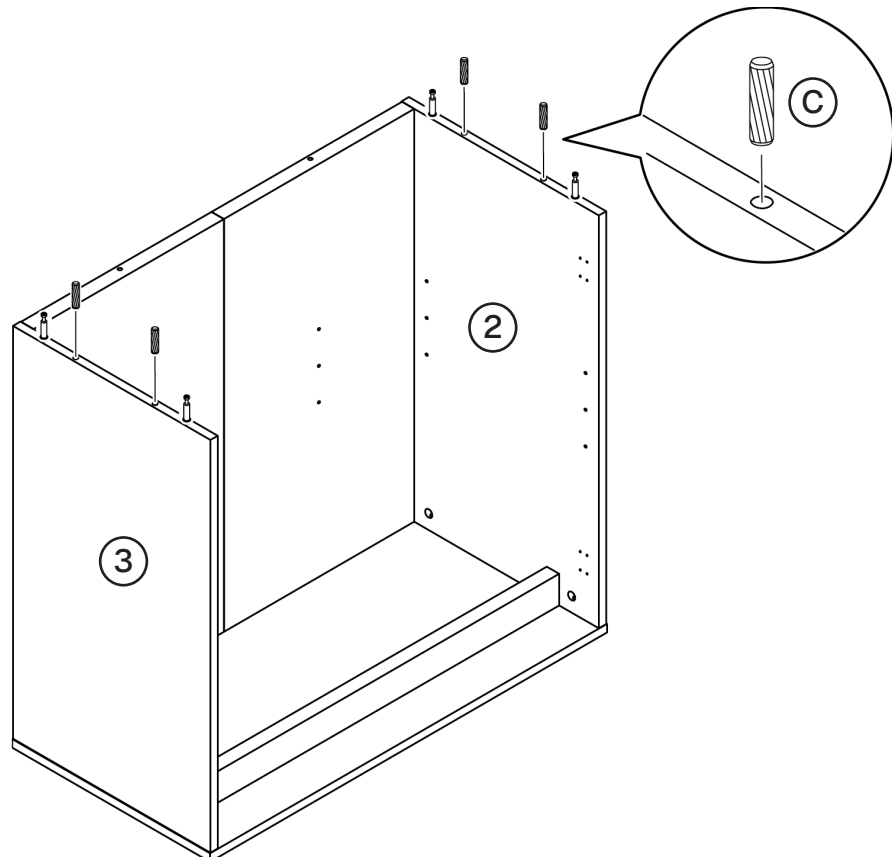

19 Attaching base pads

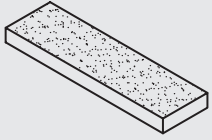

H 4x

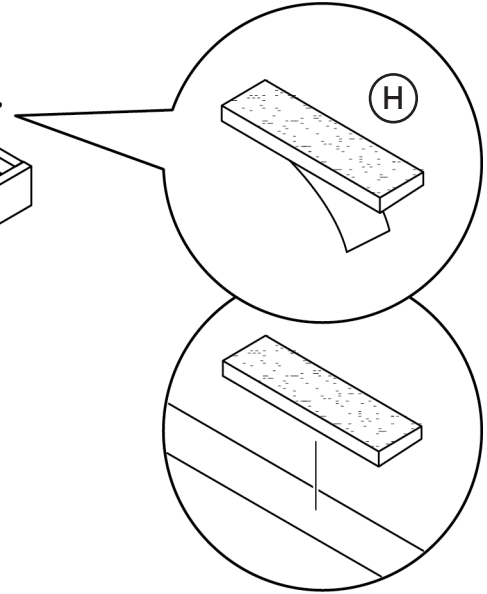
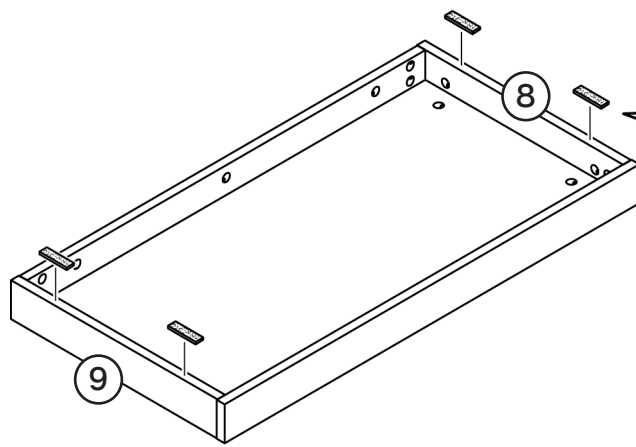

20 Attaching the base



B 6x

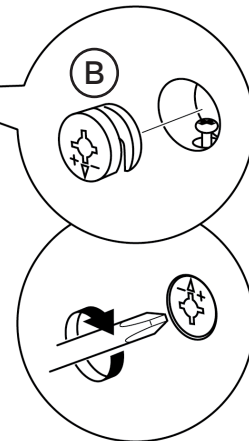
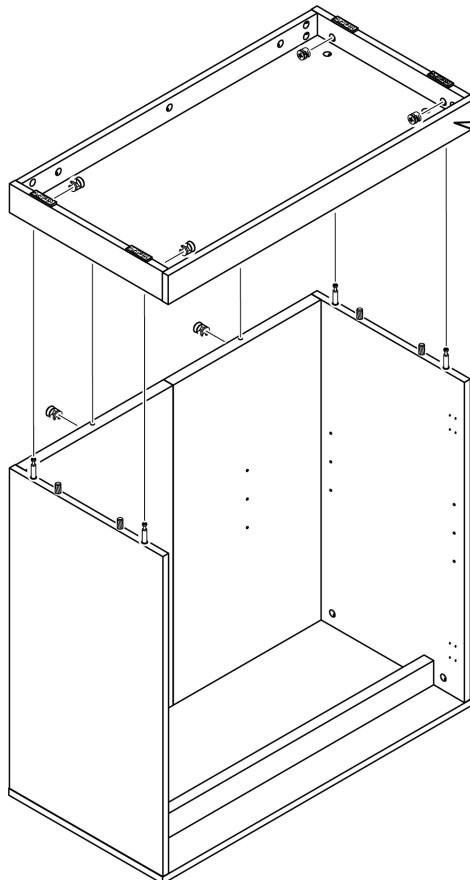

21 Attaching door hinges

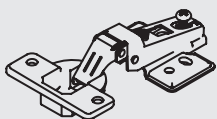

D 4x



E 8x

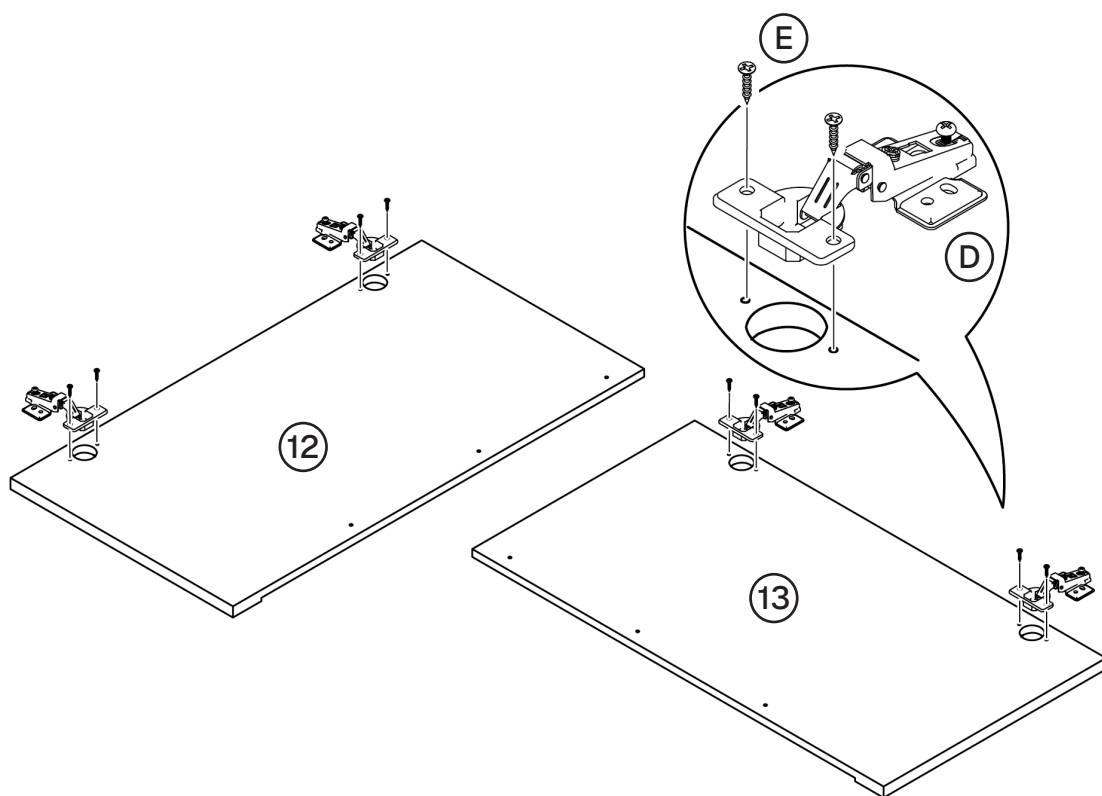

22 Attaching door handle

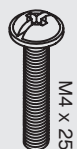

F 6x

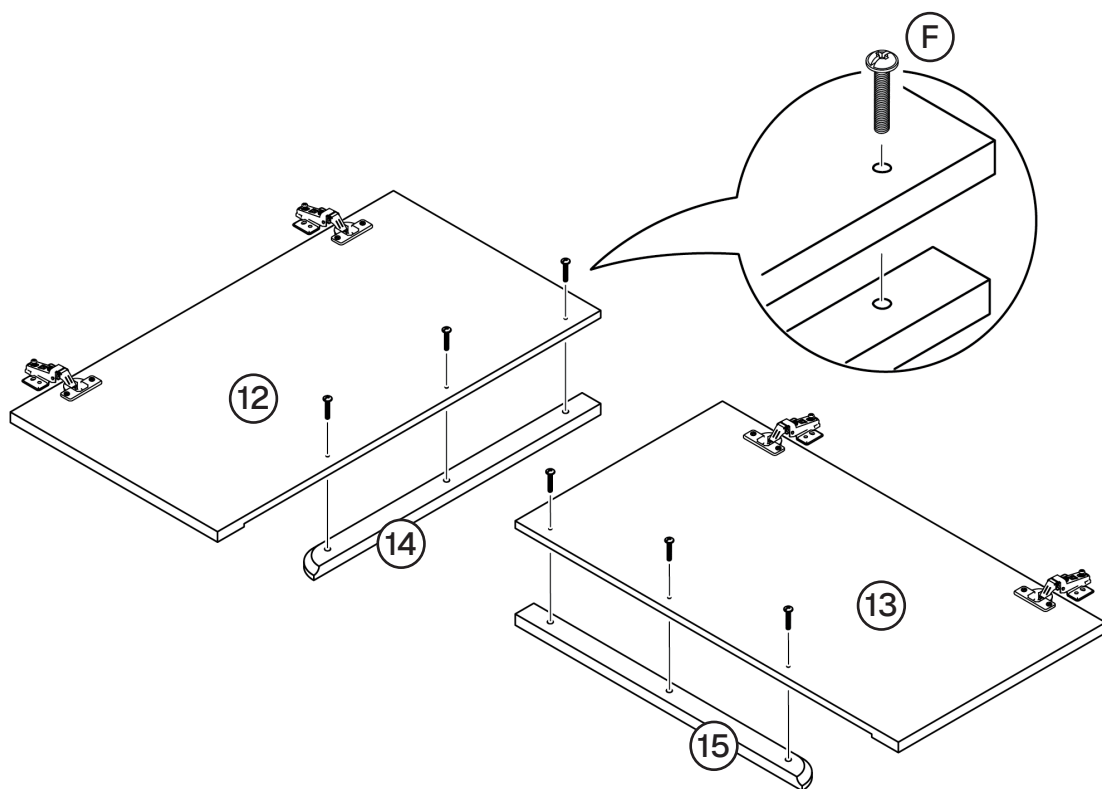

23 Attaching cabinet doors



E 16x

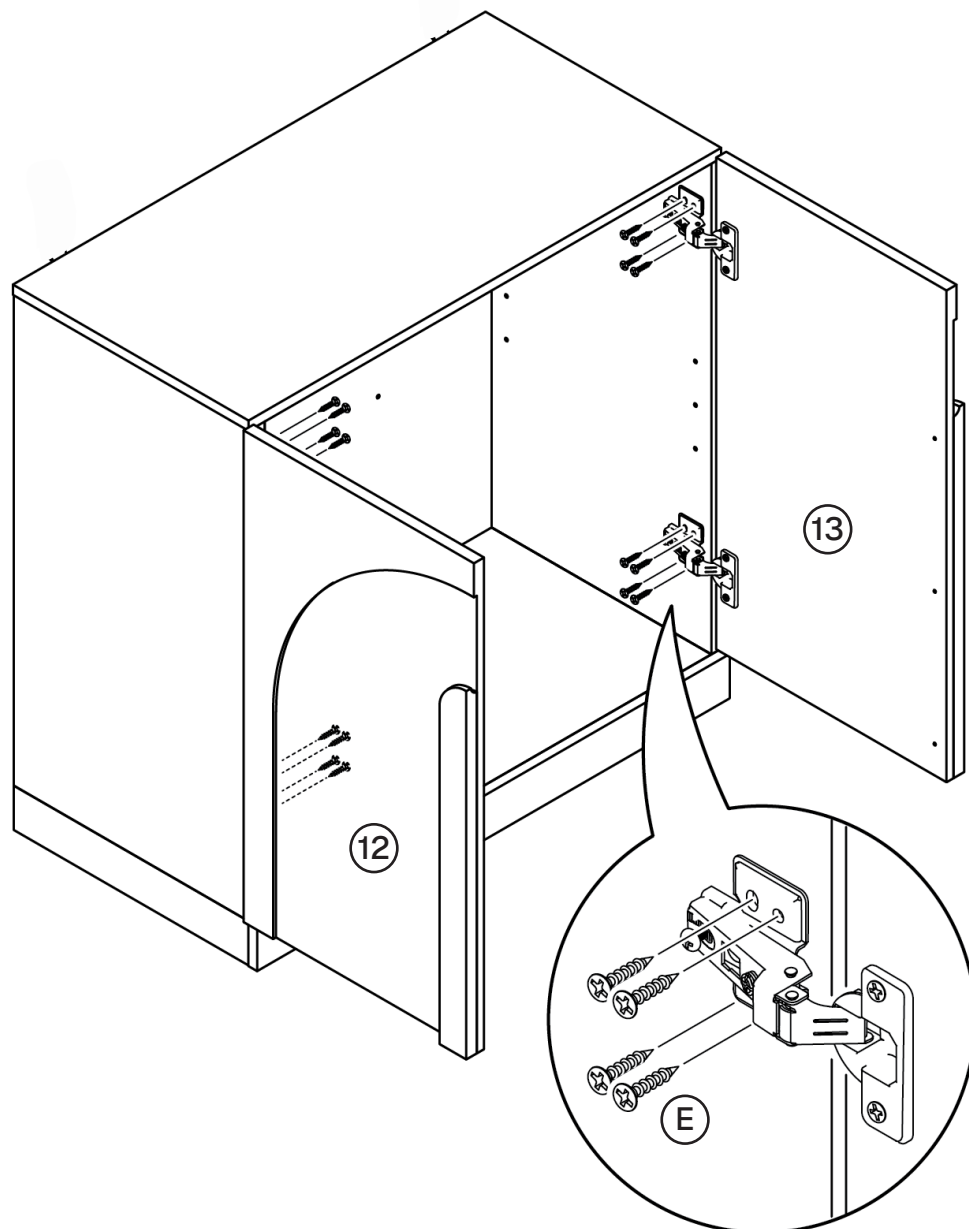

i

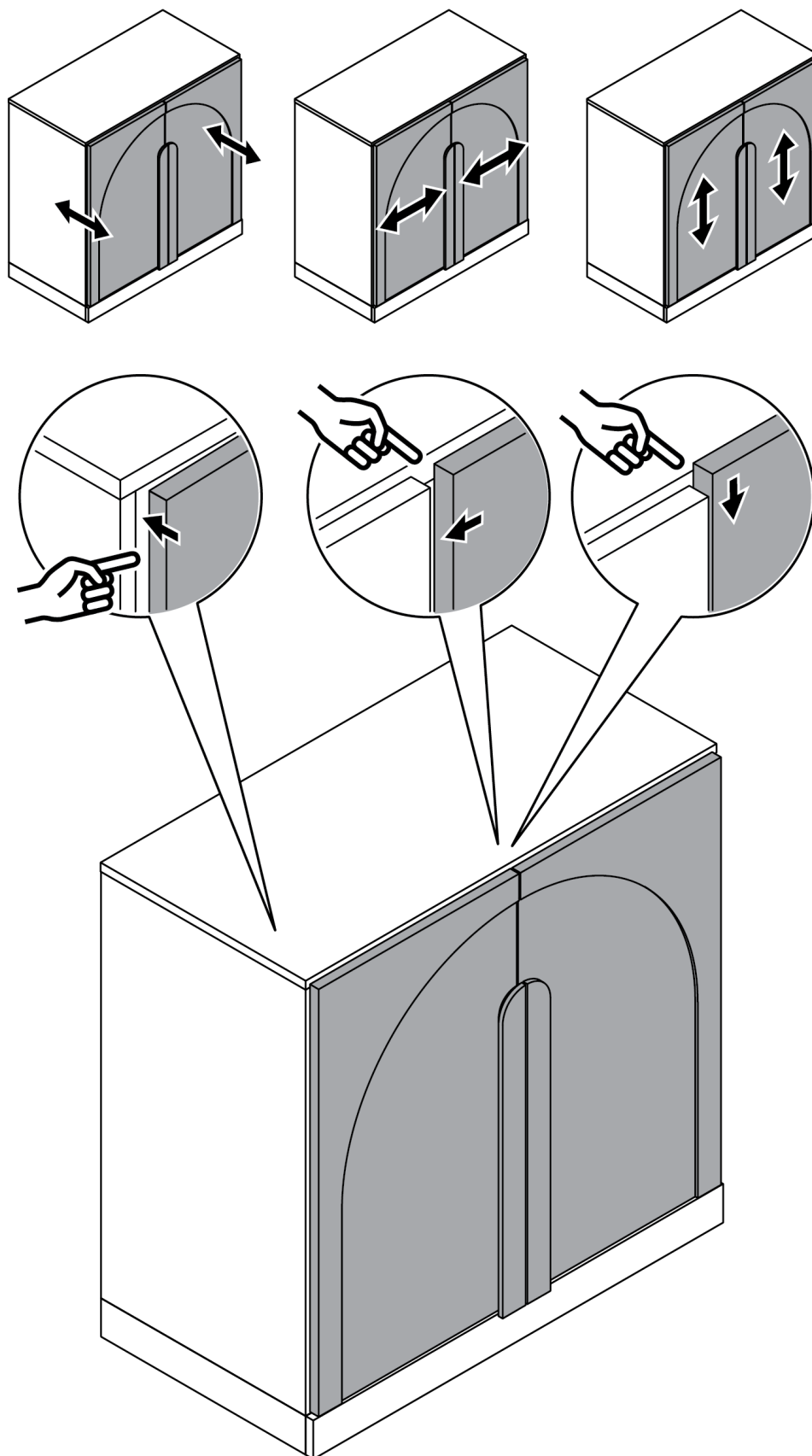

Adjust the door hinge if there is excessive gaps or height difference between the cabinet doors and/or the cabinet. Adjust both the top and bottom hinge on the same door for best result.

i

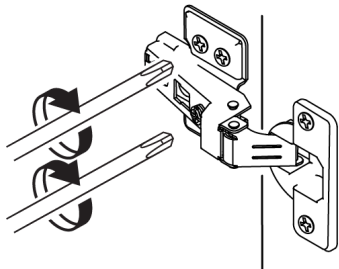
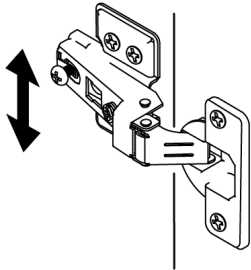
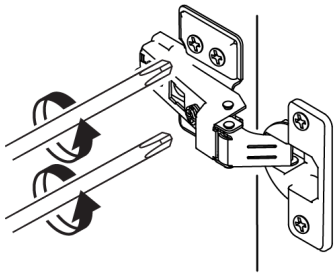
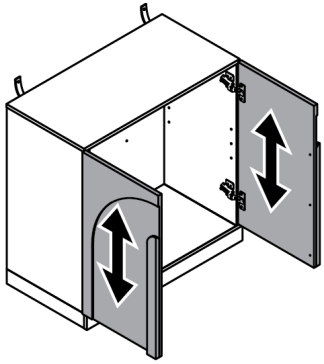

Loosen the screws on the mounting plate to adjust the door **up and down**.

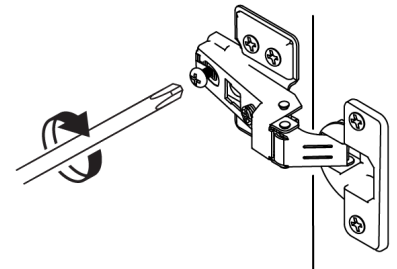
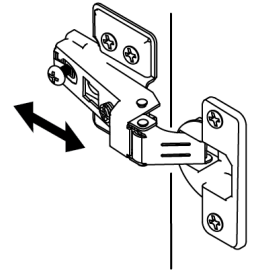
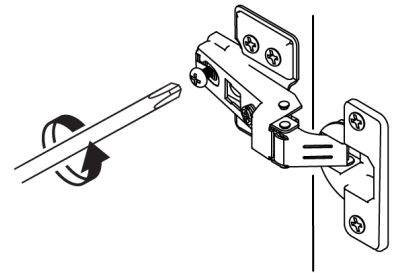
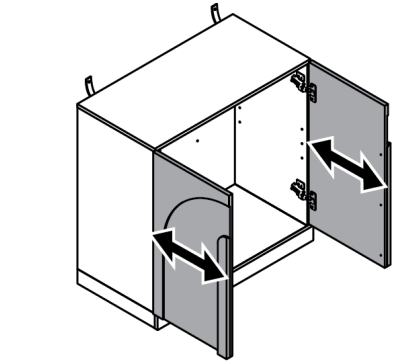
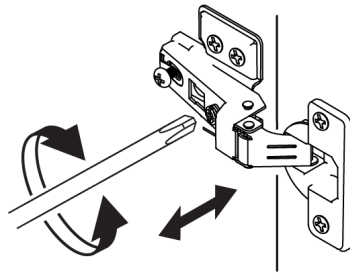
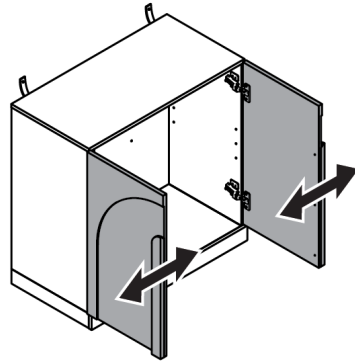

Adjust the screw on the hinge to micro-adjust the door from **side to side**.

Loosen the screws on the hinge arm to adjust the door **in and out**.

24

Inserting shelf pegs and putting on storage shelf panel



G 6x

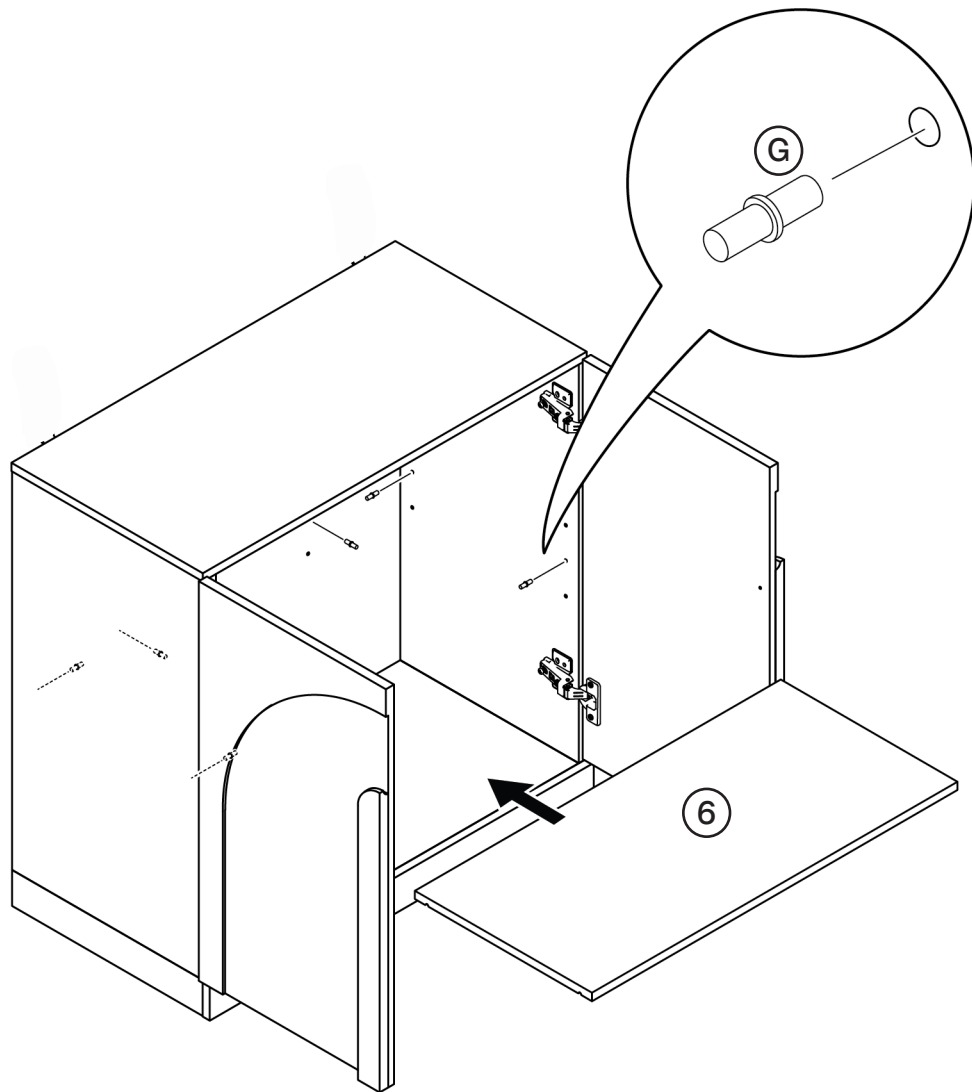

25 Attaching anti-tipping straps



J1 2x



J2 2x



M4 x 30

J3 2x

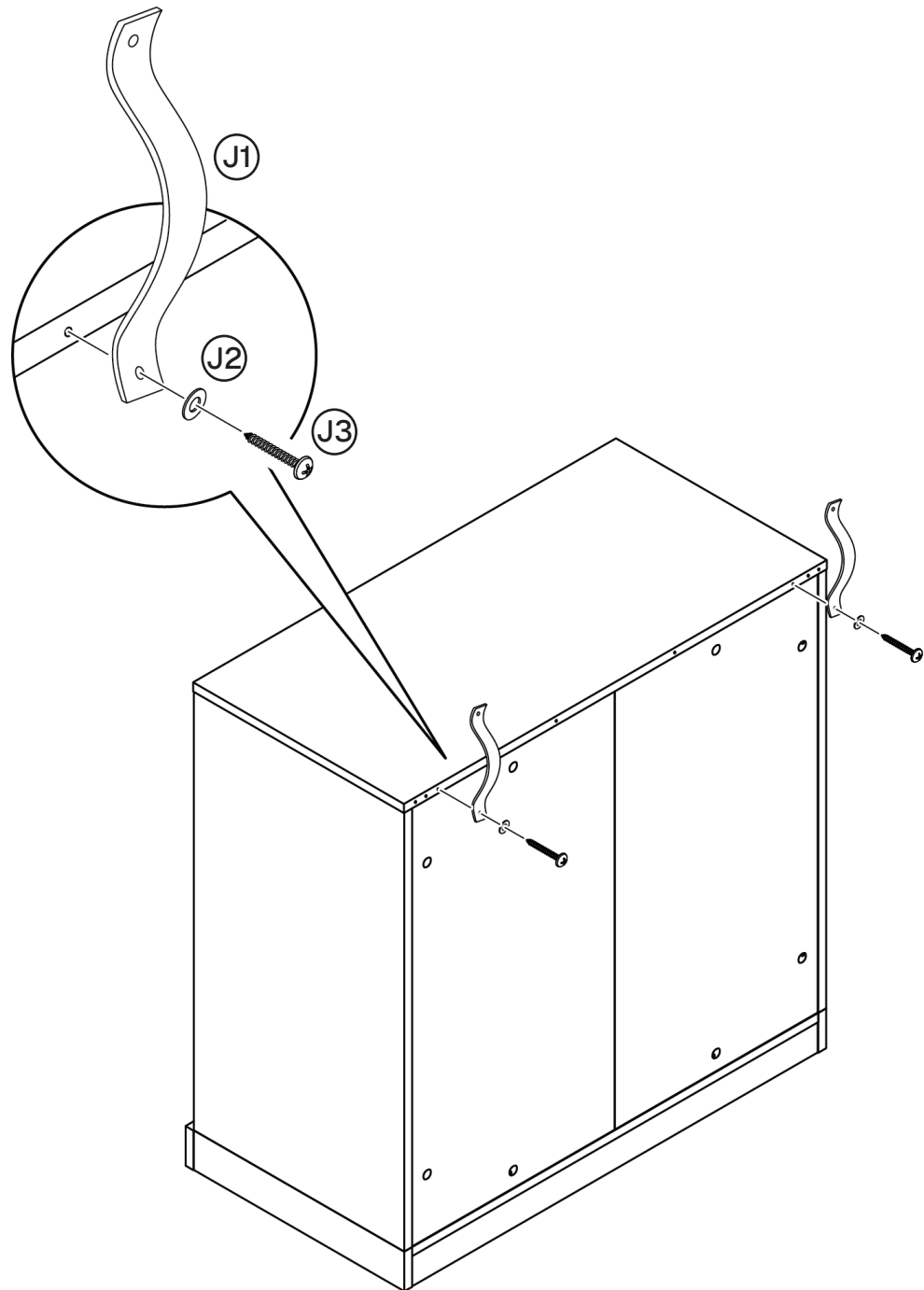

★ Note: This step does not need to be performed when combined with the bijou Hutch.

26

Affixing the sideboard to a wall

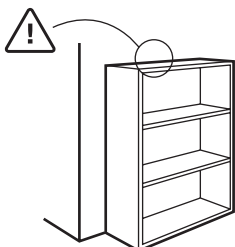
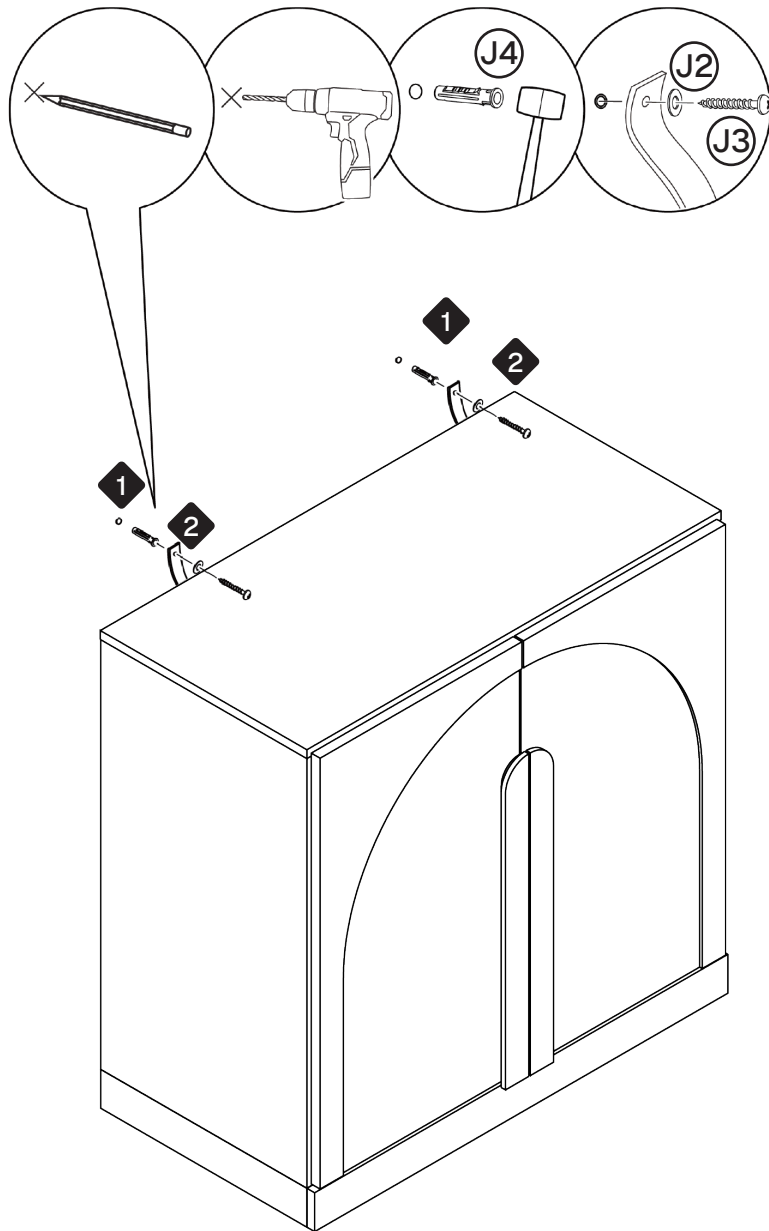
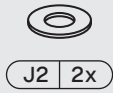

Furniture must permanently fixed to the wall stud with included anti-tipping device to prevent the furniture from tipping over.

- Mark the drill position on the wall with a pencil.
- Drill a small hole on the marked position.
- Insert a wall anchor into the drilled hole.
- Fixed the anti-tipping strap to the wall with provided screws.

*Assembly symbols

1

2

Follow sequential order

Care and Maintenance

Thank you for your purchase. We want your item to last as long as possible. To ensure the product gives you years of longevity, please follow the recommendations in this care and maintenance guide.



Maintenance

- Tighten all bolts and crews again within the first 2 weeks of assembly.
- Check the tightness of all bolts every 2 months and re-tighten them if they come loose.



Cleaning

- Clean the surface of the MDF (medium density fiberboard) with a lightly dampened cloth.
- A small amount of mild soap can be used if necessary.
- Dry the surface immediately after cleaning.



Attention

DO NOT use bleach or alcohol based cleaner to clean the surface.
DO NOT apply wood treatment on parts made with MDF.

MDF will swell and distort when exposed to water damage.
Make sure to dry the furniture immediately after cleaning.



Attention

The manufacturer and seller are not responsible for any and all liability relating to personal injury, property damage or losses, whether direct, indirect, or incidental, resulting from the incorrect attachment, improper use, inadequate maintenance, unapproved modification or neglect of the product.