















ASSEMBLY INSTRUCTIONS

Don't tighten any bolts until all bolts on a step have been started!

Thank you for purchasing this quality product. Be sure to check all packing material carefully for small parts, which may have come loose inside the carton during shipment. Identify and count all parts and compare with the HARDWARE LIST below.

NO.	PARTS LIST	PARTS NO	Q'TY
A	 Stool Back	B2-268-26FP1 B2-268-30FP1	1
B	 Fabric Seat	B2-268-2630FP2	1
C	 Left Front Leg	B2-268-26FP3 B2-268-30FP3	1
D	 Right Front Leg	B2-268-26FP4 B2-268-30FP4	1
E	 Back Leg	B2-268-26FP5 B2-268-30FP5	2
F	 Front Stretcher	B2-268-2630FP6	1
G	 Back Stretcher	B2-268-2630FP7	1

NO.	HARDWARE LIST	PARTS NO	Q'TY
1	 1/4"*2"	B2-268-2630FP8	8
2	 1/4"*1-1/2"		8
3	 1/4"		16
4	 1/4"*19mm		16
5	 8*38mmL		4
6	 Allen Wrench		1

 Philips Head Screwdriver required for assembly, but not included.

STEP 1:

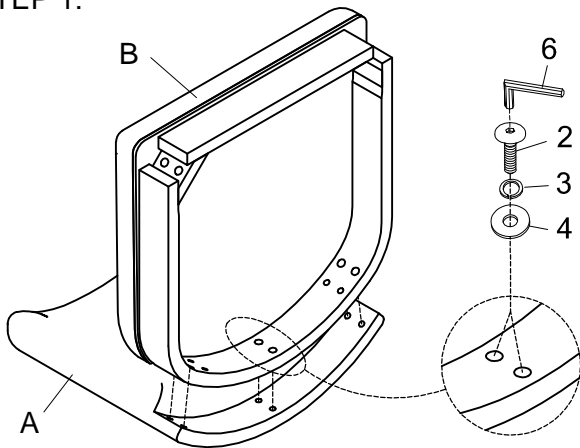

1. Loosely attach the Fabric Seat (B) to the Stool Back (A), using Bolts(6+2+3+4) to tighten, as shown.

STEP 2:

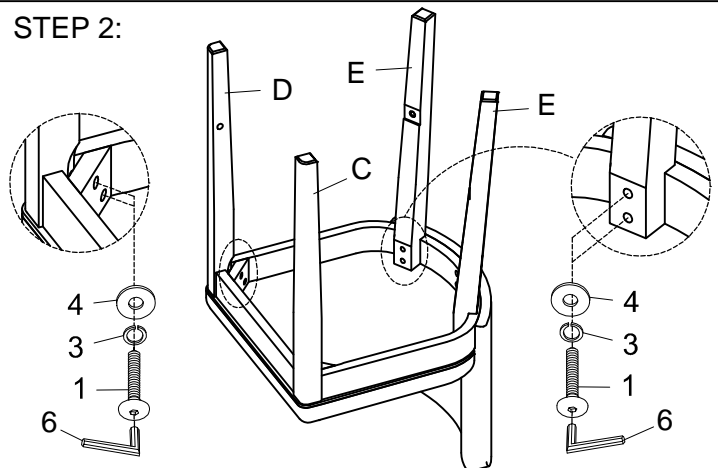

1. Loosely attach the Left leg (C) and Right leg (D) to the Fabric Seat (B), using Bolts(6+1+3+4) to tighten, as shown.
2. Loosely attach the two Back leg (E) to the Fabric Seat (B), using Bolts(6+1+3+4) to tighten, as shown.

STEP 3:

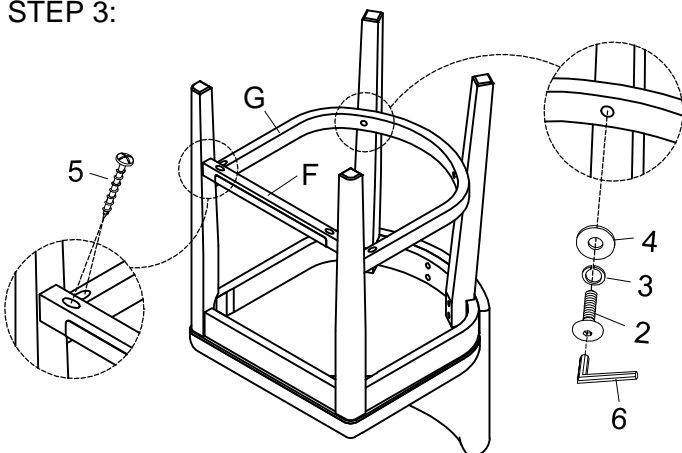

1. Loosely attach the Back stretcher (G) to the Back legs (E), using Bolts(6+2+3+4) to tighten, as shown.
2. Loosely attach the Front stretcher (F) and Back stretcher (G) to the Left legs (B) and Right leg (C), using Screw (5) with a Philips head screwdriver to tighten, as shown.

STEP 4:

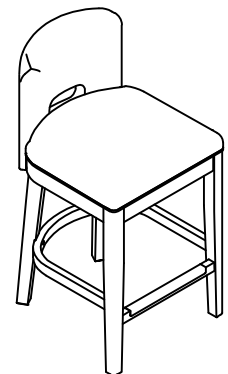

1. Right side up the stool.
2. It's complete for using.

Caution: 1. All bolts must be tightened mandatorily in the final step.
2. It is also mandatorily recommended to periodically check bolts and retighten as needed.
If you find that your furniture has a missing or damaged part, contact the dealer from which you purchased this product. They will be happy to help with any issues.