











ASSEMBLY INTRUCTIONS

TRADITIONAL ARM CHAIR

**NOTE: THIS ITEM NOT RECOMMENDED FOR COMMERCIAL USE
KEEP THIS DOCUMENT FOR REFERENCE IN CASE PARTS ARE NEEDED
DO NOT TIGHTEN SCREWS UNTIL COMPLETELY ASSEMBLE !!**

PART LISTS			
No.	Description	Sketch	Q'ty
A	CHAIR BACK		1PC
B	SEAT BOX W/ SEAT CUSHION		1PC
C	FRONT LEG		2PCS
D	ARM (L & R)		2PCS

HARDWARE LISTS				
No.	Description	Sketch	Size	Q'ty
1	BOLT		Ø5/16**1-1/2"	8PCS
2	BOLT		Ø5/16**2-1/4"	4PCS
3	BOLT		Ø5/16**3-1/4"	4PCS
4	SPRING WASHER		Ø5/16**Ø13*1.2	16PCS
5	FLAT WASHER		Ø5/16**Ø19*1.8	14PCS
6	ALLEN KEY		L57*4MM	1PC
7	WOOD PLUS			2PCS

STEP 1

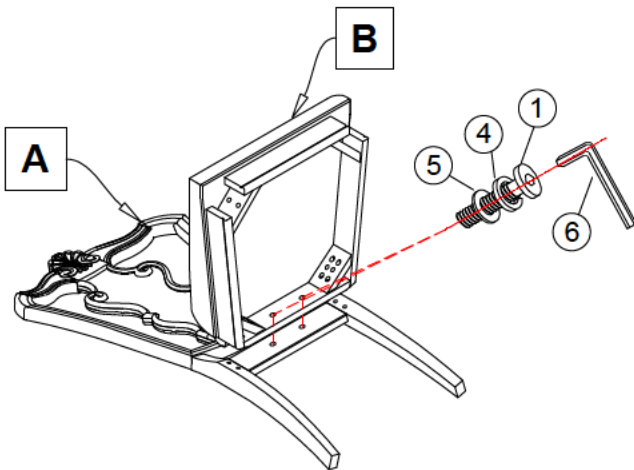

STEP 3

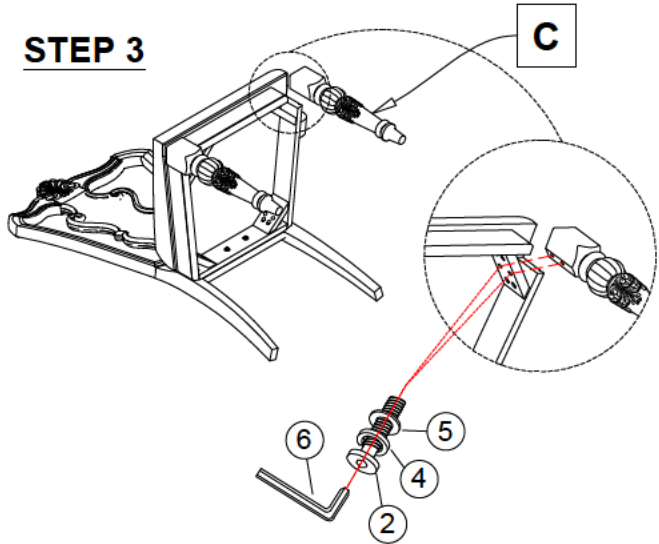

STEP 2

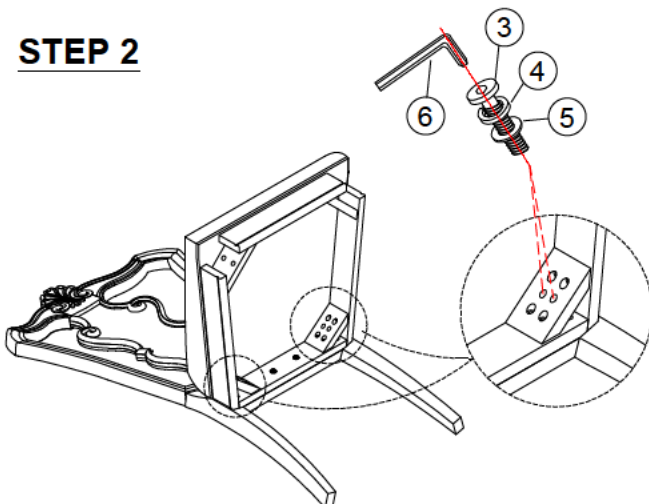

STEP 4-1

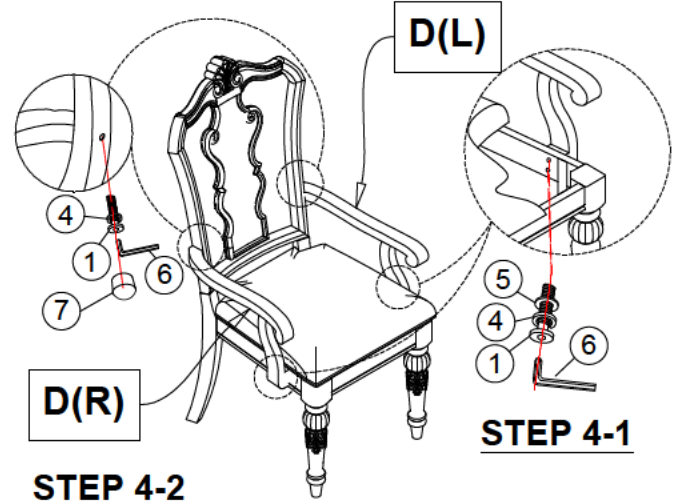

STEP 4-2