

Round Table (White Finish)

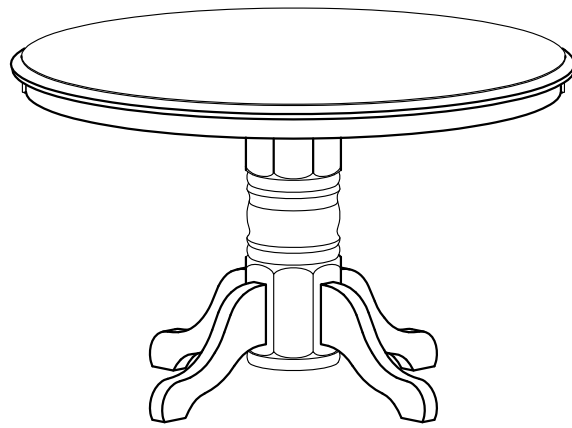

IMPORTANT NOTE

Carefully remove all the parts from the carton and put them individually on a soft cloth to prevent scratches or other damages occurring to the wood parts.

We have taken great care in the design of this product and request that you carefully and strictly follow our assembly instructions to ensure a completed product as it was designed.

PART LIST

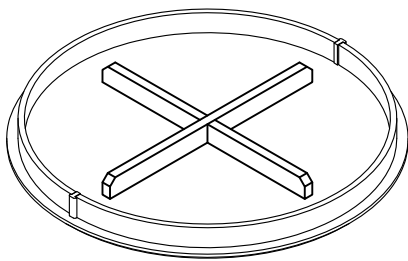

A.
Table Top
1 pc.

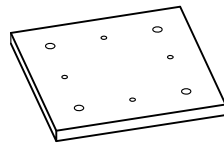

B.
Connector Panel
1 pc.

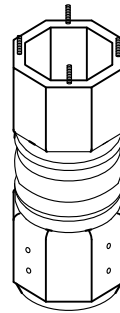

C.
Post
1 pc.



D.
Leg
4 pcs.

HARDWARE LIST

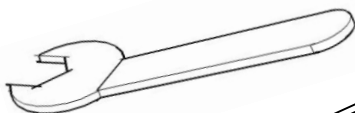

Key Wrench
1 pc.



Hex Wrench
1 pc.

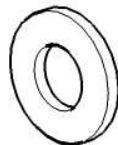

Flat Washer
16 pcs. (+ 1 extra)



Nut
12 pcs. (+1 extra)



Spring Washer
16 pcs. (+1 extra)



Head Cap Bolt
4 pcs. (+1 extra)

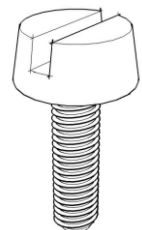

Floor Leveler
4 pcs. (+1 extra)

Assembly Instructions

IMPORTANT

* Do not tighten up all the screws until each part is properly assembled.

* You should keep Hex Wrench and Key Wrench in a safe place as you may need to tighten up the Head Cap Bolts in the future.

STEP 1

Attach Connect Panel (B) to Post (C), using Flat Washers, Spring Washers and Nuts.

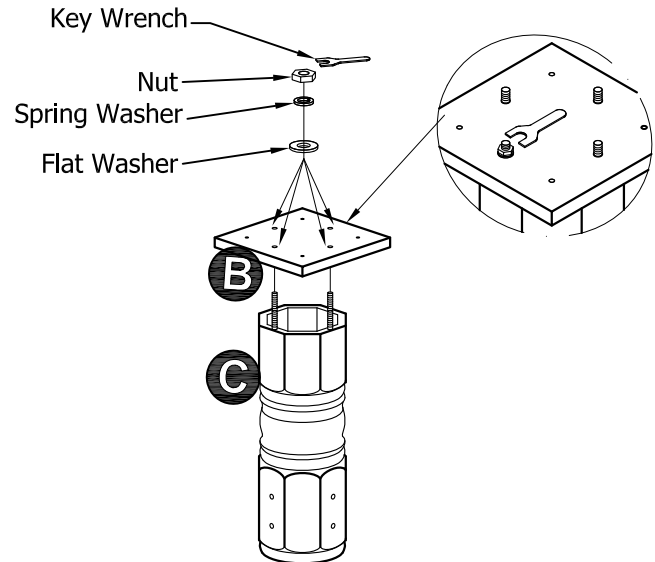
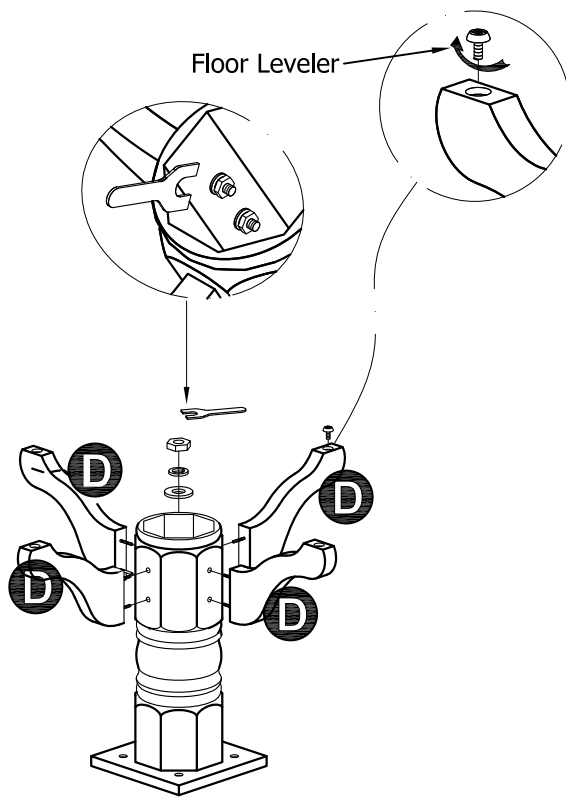

STEP 2

Turn the unit upside down on the soft cloth.

Attach Table Leg (D) to the unit, using Flat Washers, Spring Washers and Nuts.

Insert floor levelers into the pre-drilled holes of Leg (D).

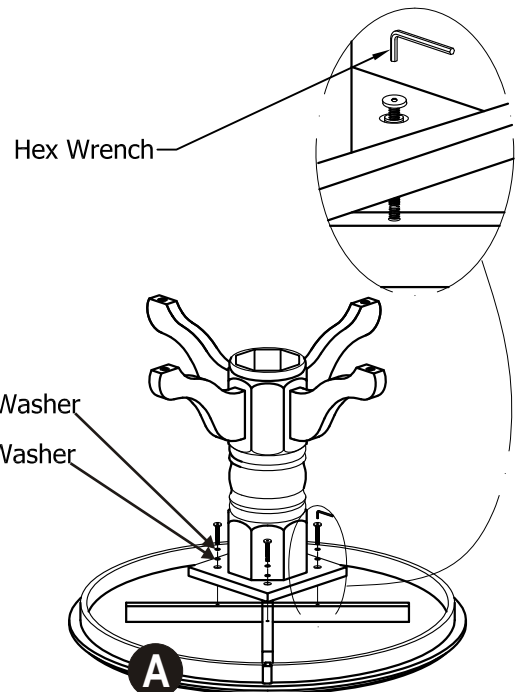

STEP 3

Place the Base Unit in step 2 on to Table Top (A) with Flat Washers, Spring Washers and Head Cap Bolts.

Turn the assembled unit to its upright position.