

# *ASSEMBLY INSTRUCTIONS*



*BAR TABLE*

# ASSEMBLY INSTRUCTIONS

## ASSEMBLY TIPS:

1. Remove hardware from box and sort by size.
2. Please check to see that all hardware and parts are present prior to start of assembly.
3. Please follow attached instructions in the same sequence as numbered to assure fast & easy assembly.





## WARNING!

1. Don't attempt to repair or modify parts that are broken or defective. Please contact the store immediately.
2. This product is for home use only and not intended for commercial establishments.

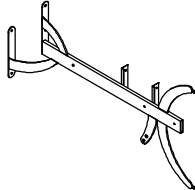
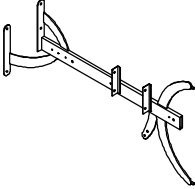
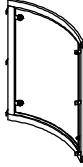
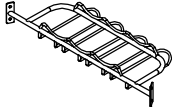
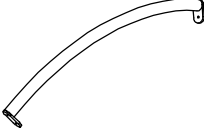

ASSEMBLY TIME 60 MINUTES

## PARTS IDENTIFICATION







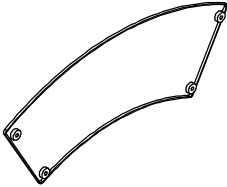
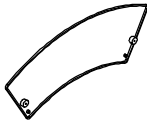
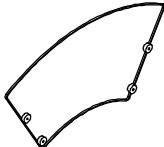





A	LEFT LEG		1PC
B	RIGHT LEG		1PC
C	FRONT FRAME		1PC
D	HANGER BRACKET		1PC
E	BOTTOM SUPPORT		1PC
F	GLASS SHELF SUPPORT		2PCS

# ASSEMBLY INSTRUCTIONS

## PARTS IDENTIFICATION

G	UPPER TOP GLASS		1PC
H	GLASS SHELF		2PCS
I	LOWER TOP GLASS		1PC

## HARDWARE IDENTIFICATION

1	ALLEN BOLT-MEDIUM (1/4" x 8mm BLK)		22PCS	7	ALLEN BOLT-LARGE (1/4" x 38mm BLK)		3PCS
2	ALLEN BOLT-SMALL (1/4" x 9mm BLK)		4PCS	8	NUT (1/4" BLK)		3PCS
3	BOLT (3/16" x 12mm BLK)		4PCS	9	WASHER (φ16mm BLK)		3PCS
4	SMALL WASHER (φ15mm)		4PCS	10	PLASTIC WASHER (φ26mm)		3PCS
5	SUCTION CUP (6mm)		4PCS	11	ALLEN WRENCH (4mm)		1PC
6	FLOOR LEVELER (1/4" x 6mm BLK)		4PCS	12	HEXAGONAL WRENCH (1/4")		1PC

NOTE: PART 7,8,9,AND 10 ARE NEEDED ONLY WHEN BUYING 2 UNITS

# ASSEMBLY INSTRUCTIONS

**STEP 1** Do not tighten until each step is completed or instructed.

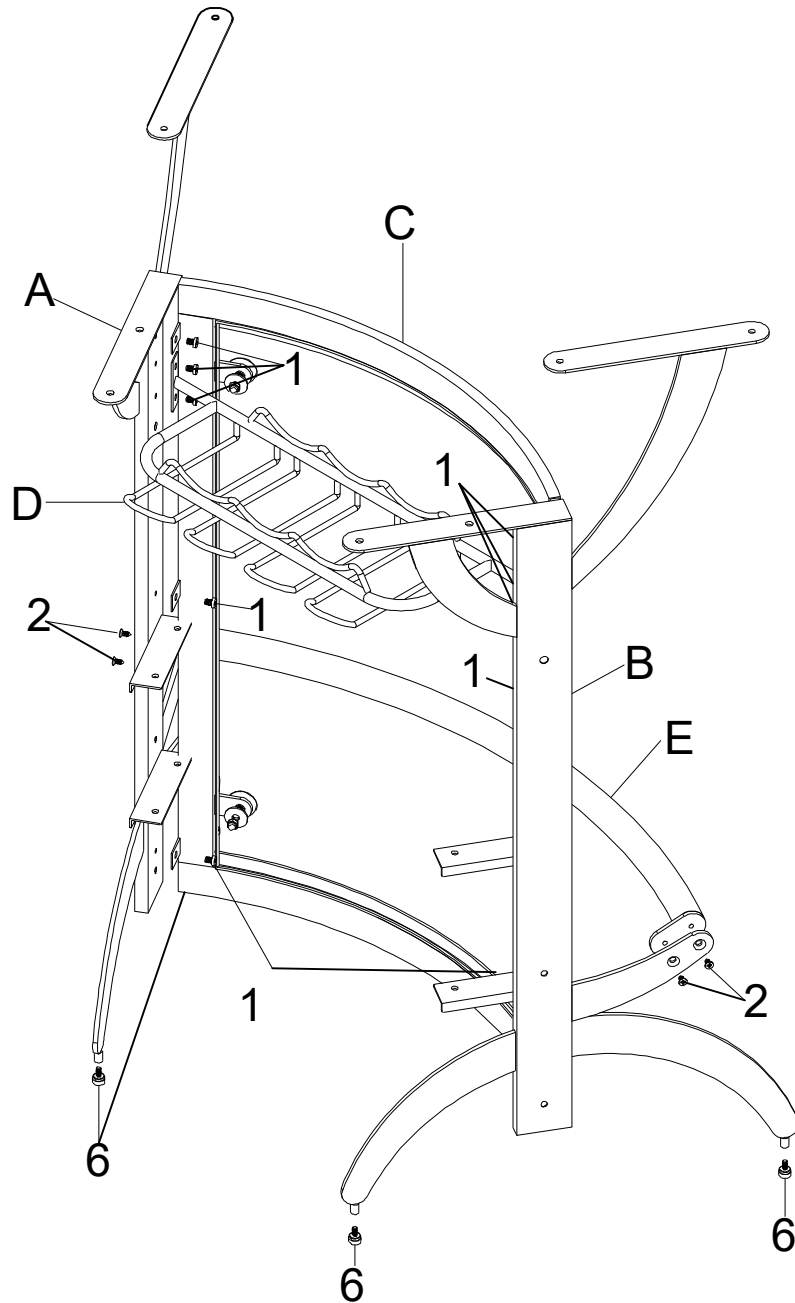

# ASSEMBLY INSTRUCTIONS

## STEP 2

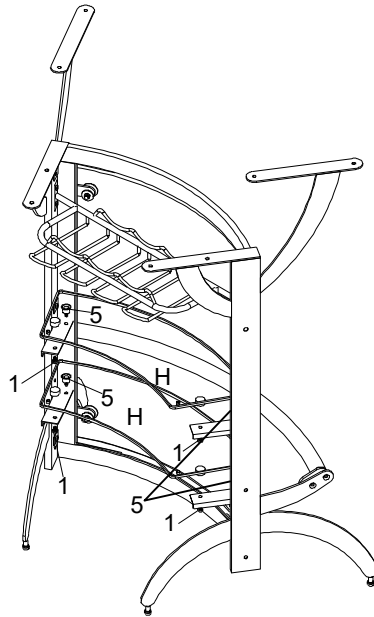

## STEP 3

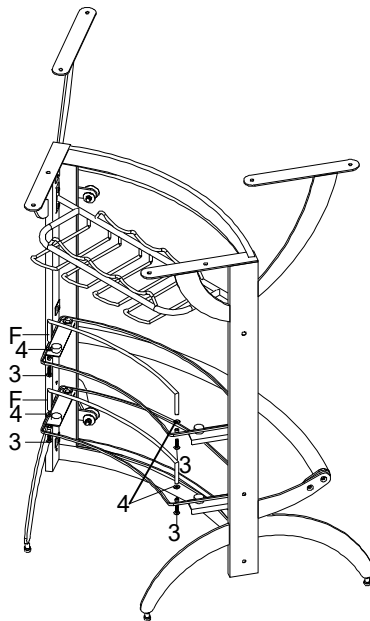

# ASSEMBLY INSTRUCTIONS

## STEP 4

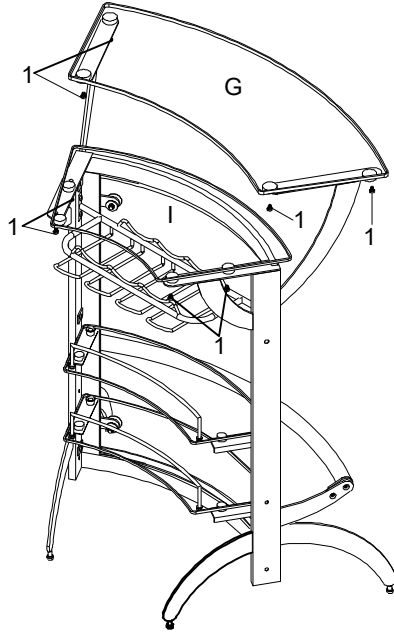

## STEP 5

### COMPLETE

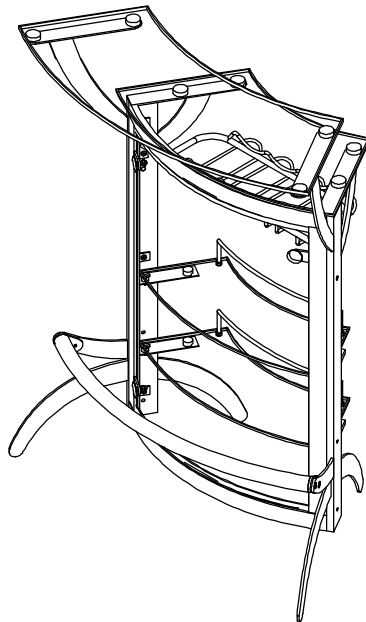

# ASSEMBLY INSTRUCTIONS

## STEP 6

NOTE: WHEN BUYING 2 OR 3 UNITS

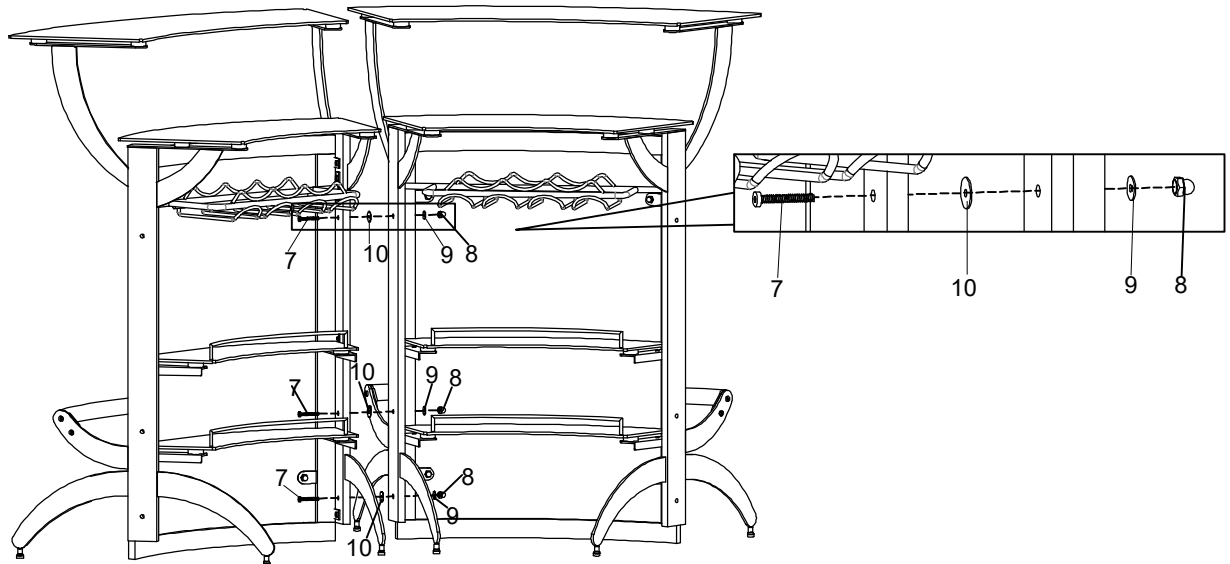

How to clean Acrylic product:  
Using a dry soft microfiber cloth, lightly brush off any dust.  
For additional care, dampen the cloth with warm water.  
For deepest cleaning, use an Acrylic cleaner.

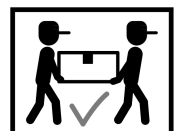

# ASSEMBLY INSTRUCTIONS

<b>Product Size : 851 X 533 X 1050 H (MM)</b>
<b>Product Size : 33 1/2" X 21" X 41 1/2"</b>

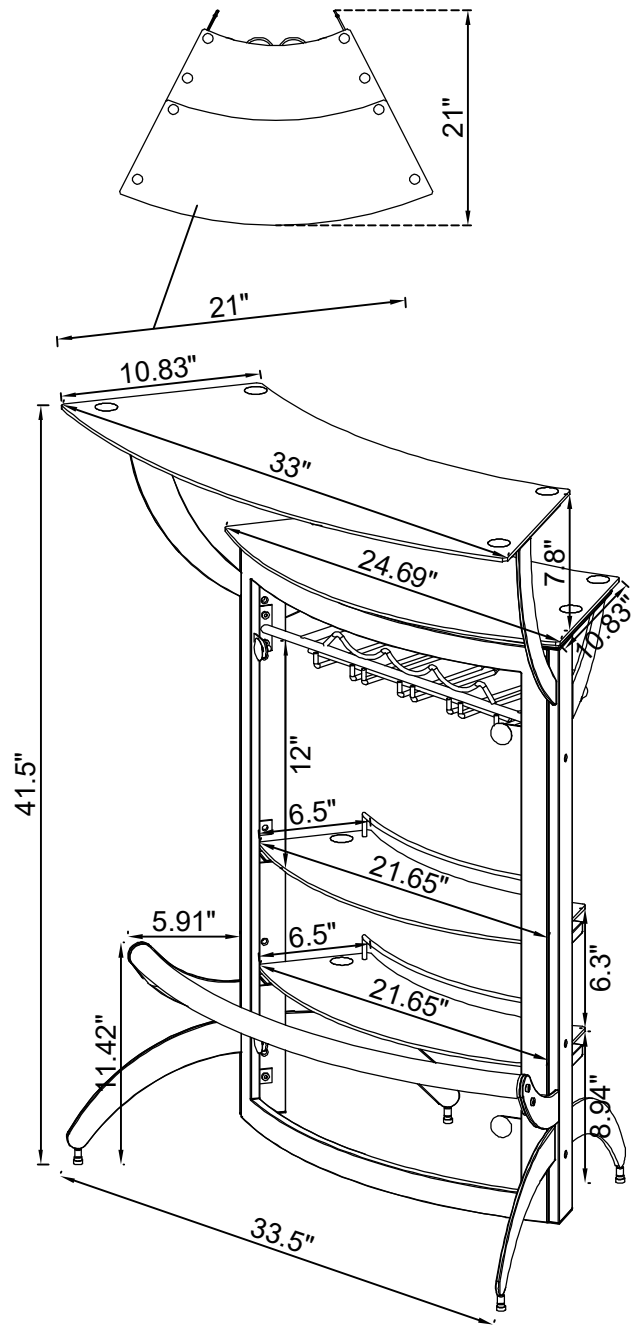

Note : Dimension tolerance  $\pm 5\%$

# ASSEMBLY INSTRUCTIONS

Product Size : 1600 X 883 X 1050 H (MM)

Product Size : 63" X 34 <sup>3</sup>/<sub>4</sub>" X 41 <sup>1</sup>/<sub>2</sub>"

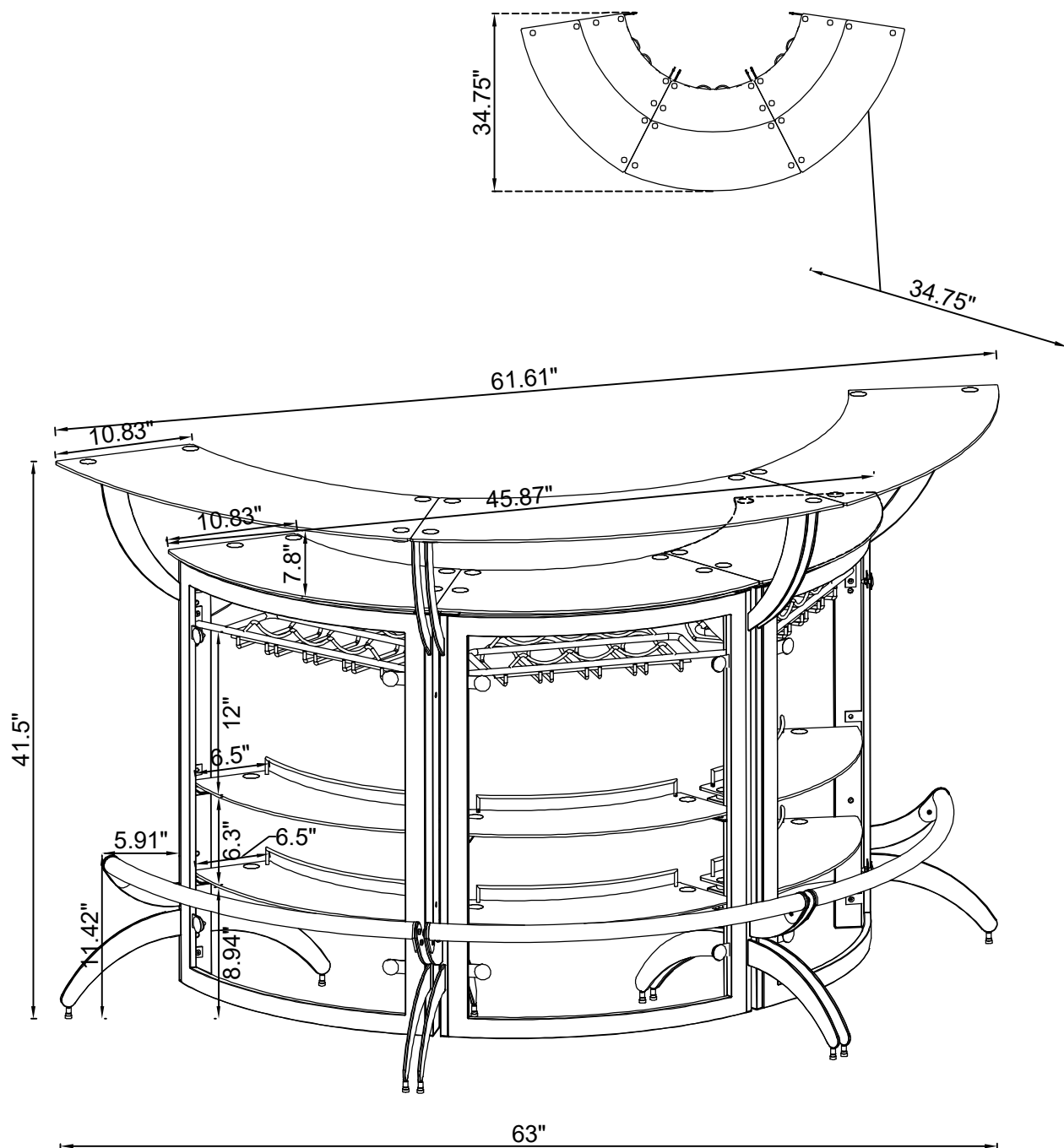

Note : Dimension tolerance  $\pm 5\%$

# *ASSEMBLY INSTRUCTIONS*



*BAR TABLE*

# ASSEMBLY INSTRUCTIONS

## ASSEMBLY TIPS:

1. Remove hardware from box and sort by size.
2. Please check to see that all hardware and parts are present prior to start of assembly.
3. Please follow attached instructions in the same sequence as numbered to assure fast & easy assembly.



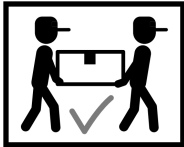

## WARNING!

1. Don't attempt to repair or modify parts that are broken or defective. Please contact the store immediately.
2. This product is for home use only and not intended for commercial establishments.

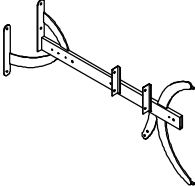
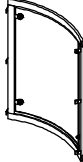
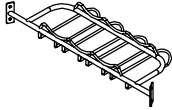
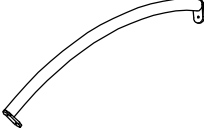

ASSEMBLY TIME 60 MINUTES

## PARTS IDENTIFICATION







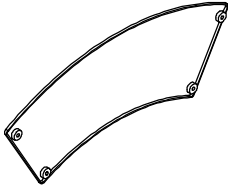
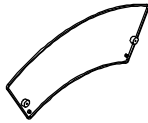
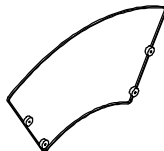





A	LEFT LEG		1PC
B	RIGHT LEG		1PC
C	FRONT FRAME		1PC
D	HANGER BRACKET		1PC
E	BOTTOM SUPPORT		1PC
F	GLASS SHELF SUPPORT		2PCS

# ASSEMBLY INSTRUCTIONS

## PARTS IDENTIFICATION

G	UPPER TOP GLASS		1PC
H	GLASS SHELF		2PCS
I	LOWER TOP GLASS		1PC

## HARDWARE IDENTIFICATION

1	ALLEN BOLT-MEDIUM (1/4" x 8mm BLK)		22PCS	7	ALLEN BOLT-LARGE (1/4" x 38mm BLK)		3PCS
2	ALLEN BOLT-SMALL (1/4" x 9mm BLK)		4PCS	8	NUT (1/4" BLK)		3PCS
3	BOLT (3/16" x 12mm BLK)		4PCS	9	WASHER (φ16mm BLK)		3PCS
4	SMALL WASHER (φ15mm)		4PCS	10	PLASTIC WASHER (φ26mm)		3PCS
5	SUCTION CUP (6mm)		4PCS	11	ALLEN WRENCH (4mm)		1PC
6	FLOOR LEVELER (1/4" x 6mm BLK)		4PCS	12	HEXAGONAL WRENCH (1/4")		1PC

# ASSEMBLY INSTRUCTIONS

**STEP 1** Do not tighten until each step is completed or instructed.

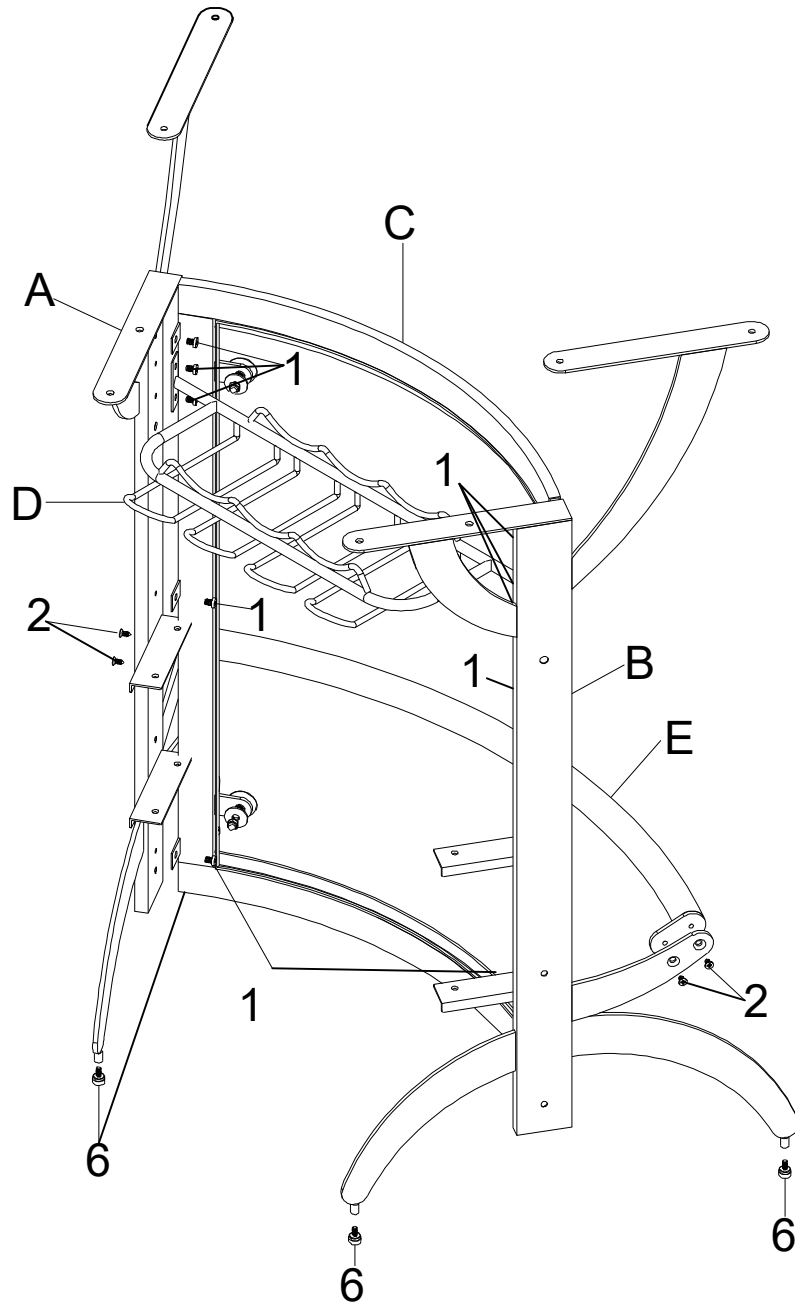

# ASSEMBLY INSTRUCTIONS

## STEP 2

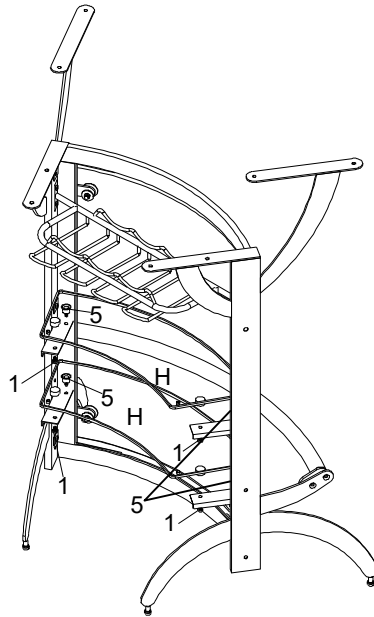

## STEP 3

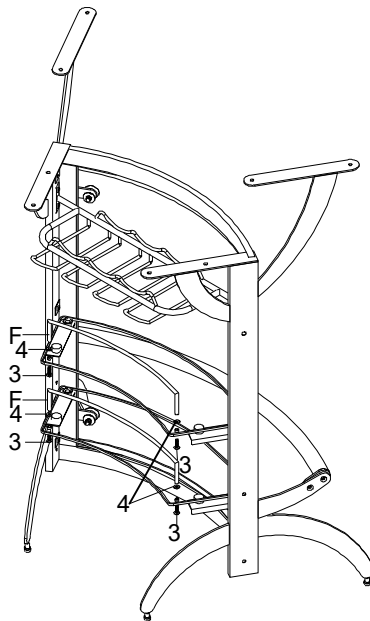

# ASSEMBLY INSTRUCTIONS

## STEP 4

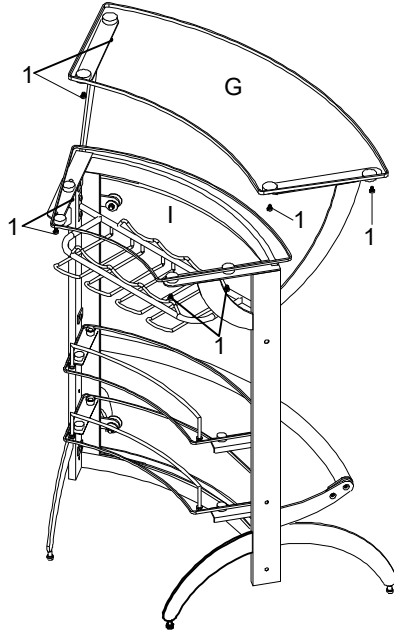

## STEP 5

### COMPLETE

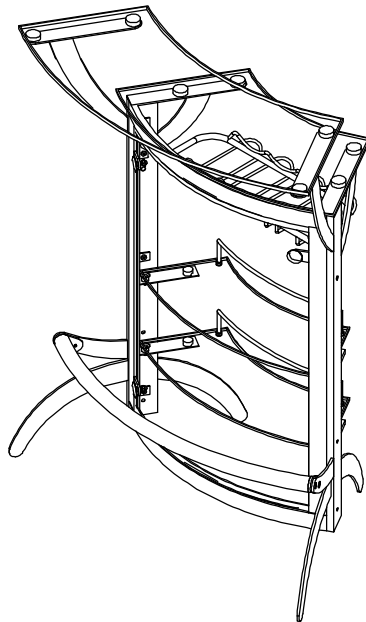

# ASSEMBLY INSTRUCTIONS

## STEP 6

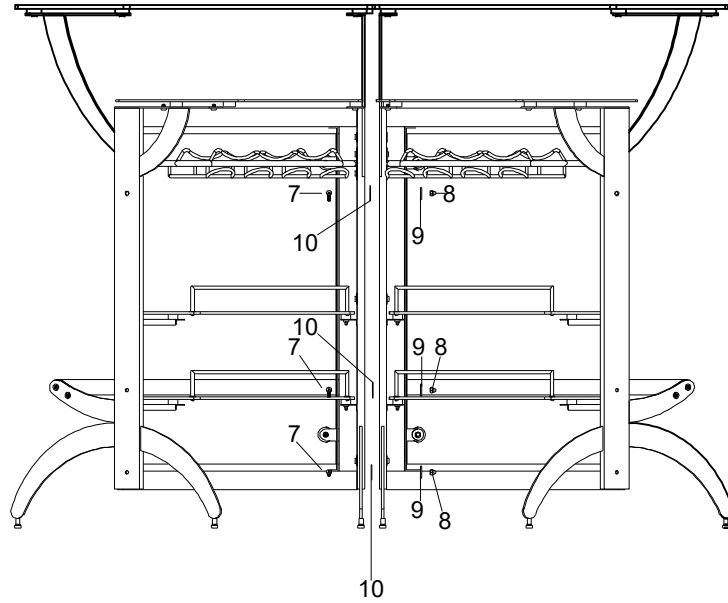

How to clean Acrylic product:  
Using a dry soft microfiber cloth, lightly brush off any dust.  
For additional care, dampen the cloth with warm water.  
For deepest cleaning, use an Acrylic cleaner.

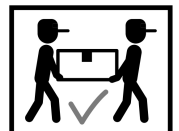

# ASSEMBLY INSTRUCTIONS

<b>Product Size : 851 X 533 X 1050 H (MM)</b>
<b>Product Size : 33 1/2" X 21" X 41 1/2"</b>

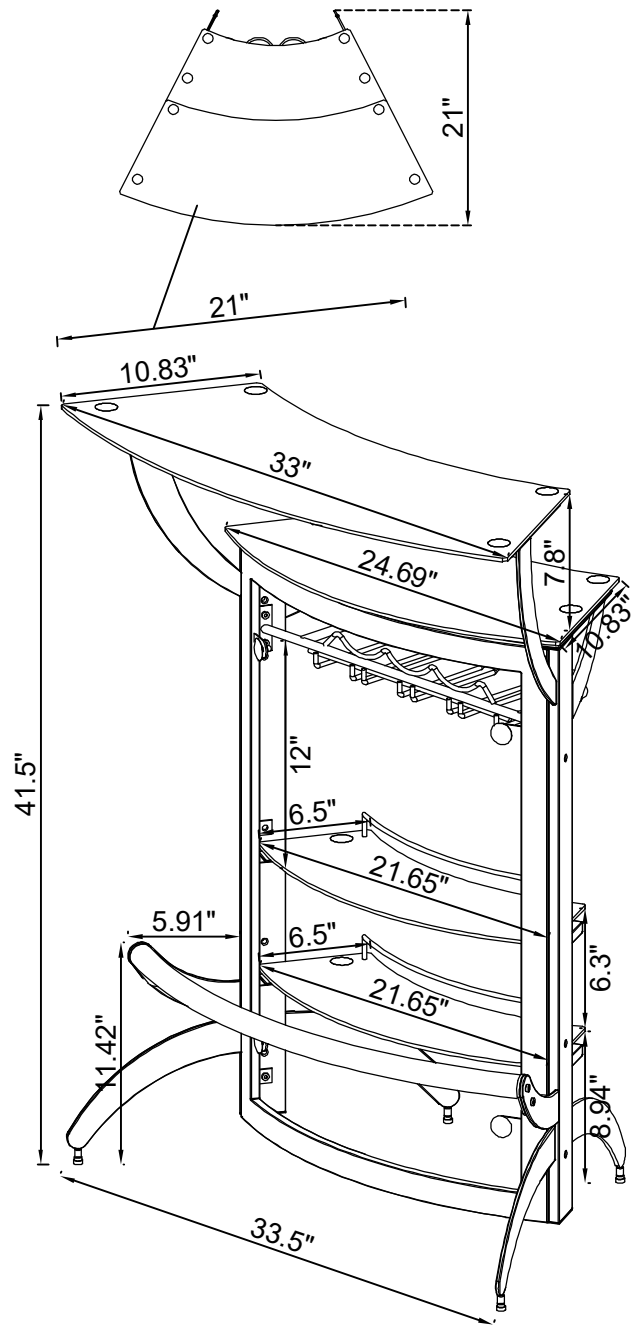

Note : Dimension tolerance  $\pm 5\%$

# ASSEMBLY INSTRUCTIONS

Product Size : 1600 X 883 X 1050 H (MM)

Product Size : 63" X 34 <sup>3</sup>/<sub>4</sub>" X 41 <sup>1</sup>/<sub>2</sub>"

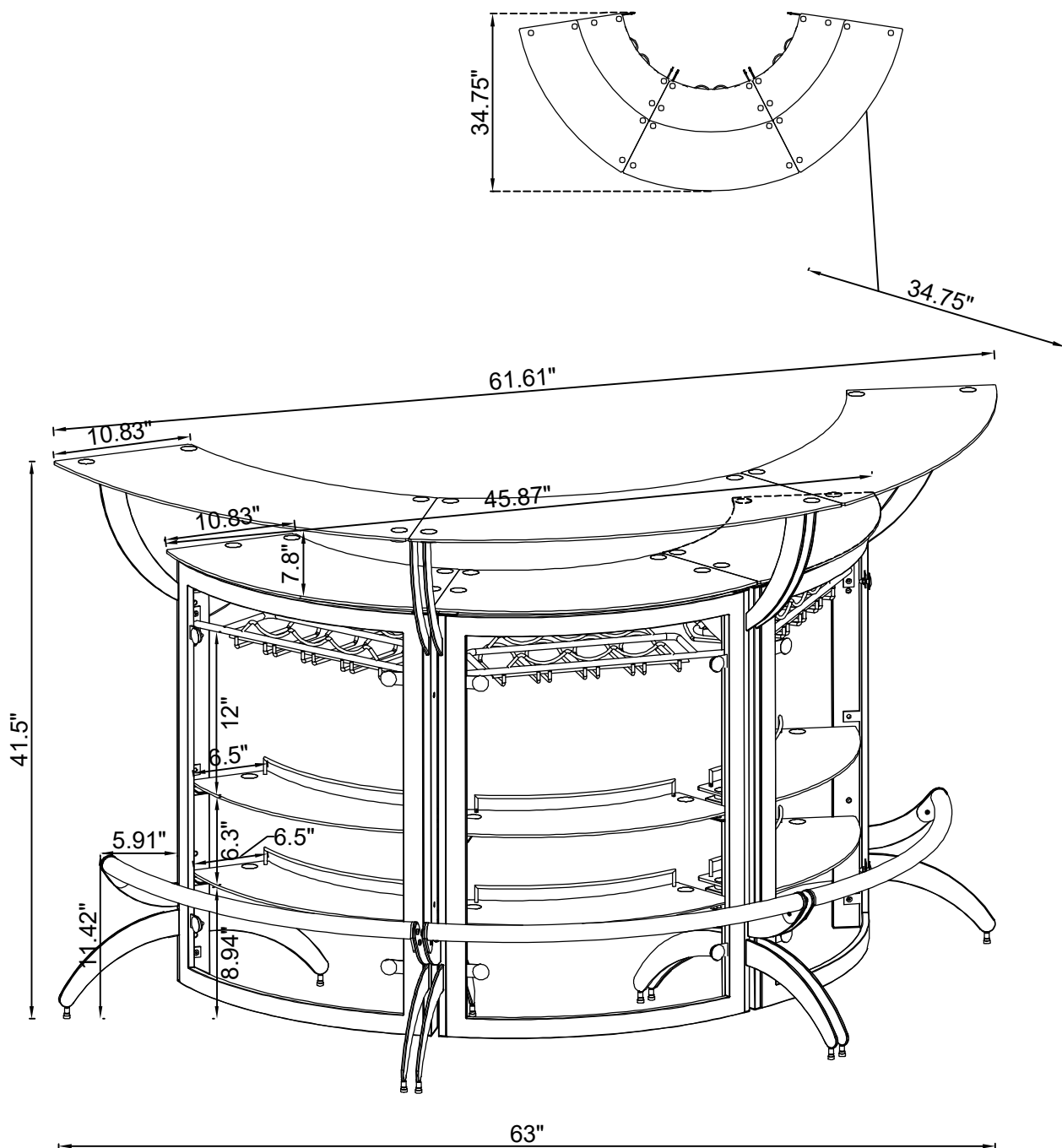

Note : Dimension tolerance  $\pm 5\%$