

Installation & Assembly

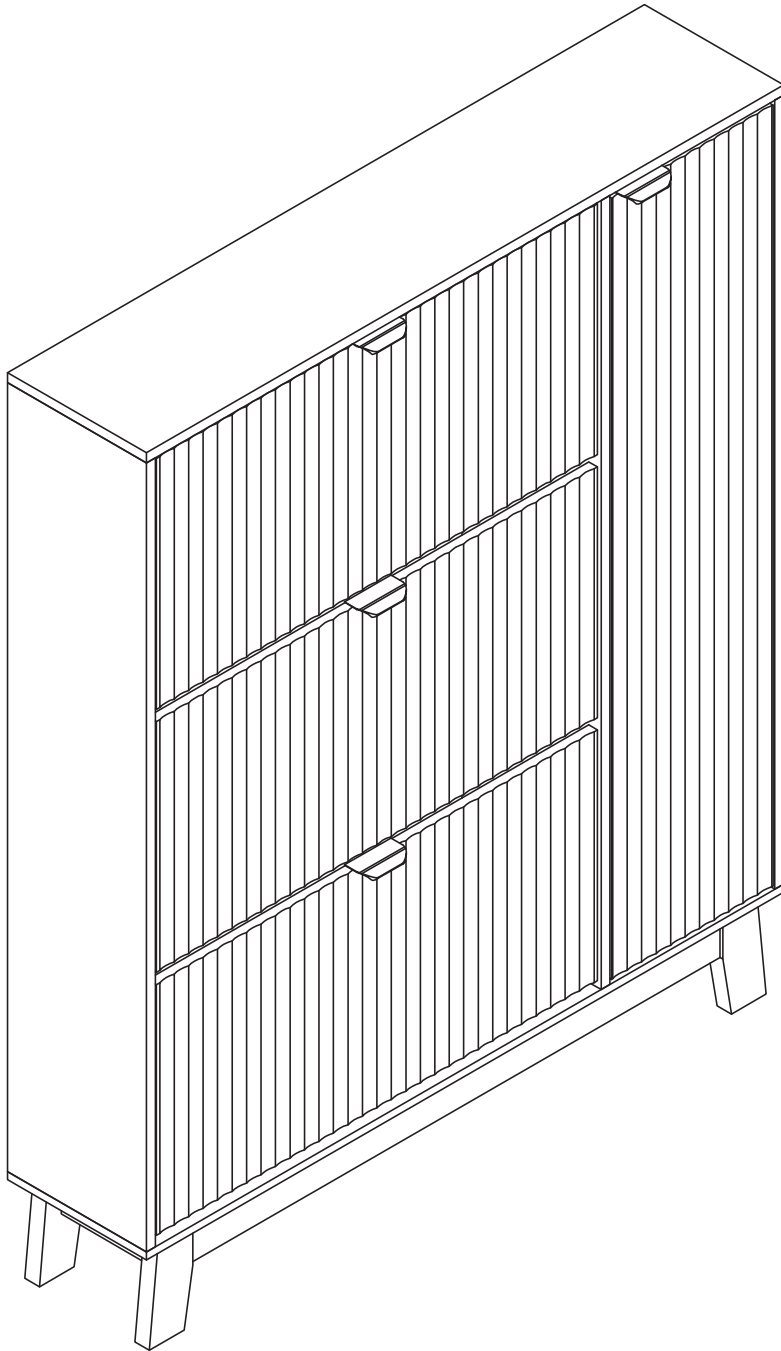

Version:1.0

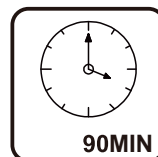
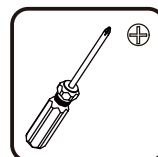
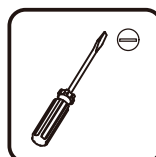

EN_IMPORTANT, RETAIN FOR FUTURE REFERENCE: READ CAREFULLY.

USING CAM LOCK AND QUICKFIT

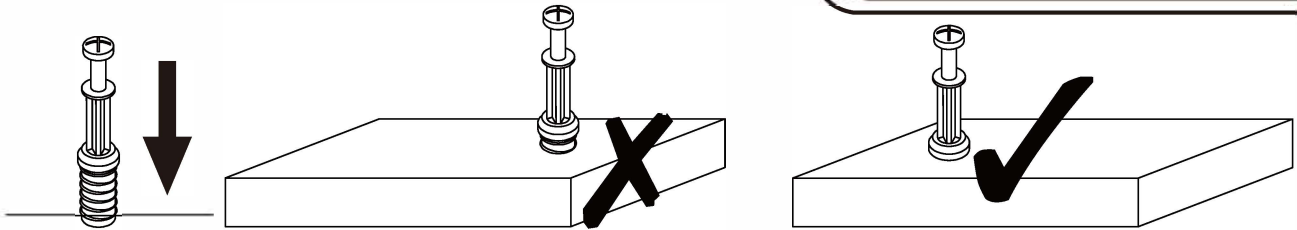

EN_QUICKFIT: Tighten quickfit until shoulder is flush with panel. Do not overtighten or undertighten.

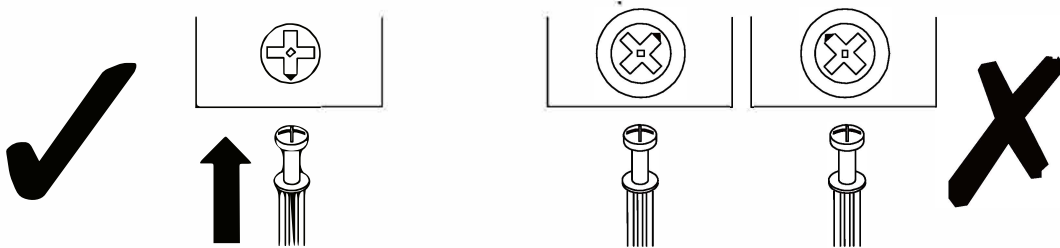

EN_CAM LOCK: When fitting cam lock, ensure starting position is correct before you insert connecting quickfit.

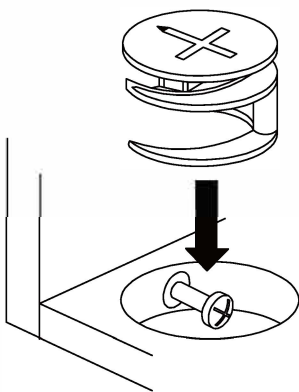

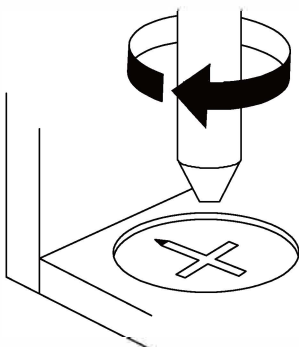

EN_Quickfit head should be in the centre of the cam lock when the two panels are joined.
Cam lock should be inserted before quickfit.



EN_Turn cam lock clockwise to tighten.

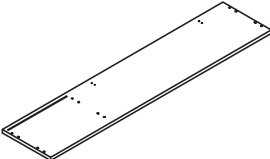
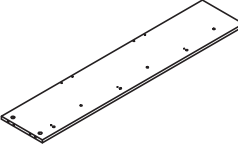
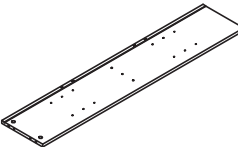
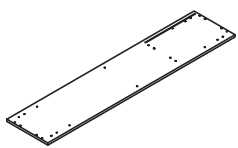
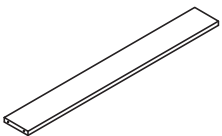
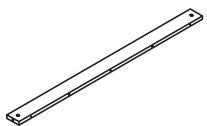
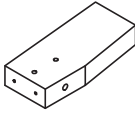
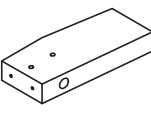
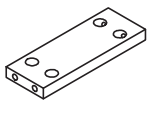
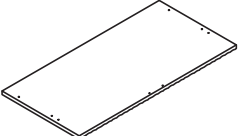
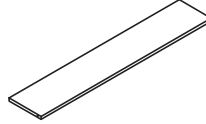

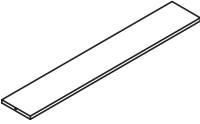
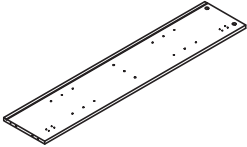
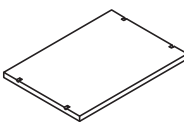
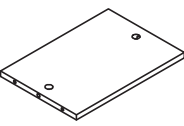
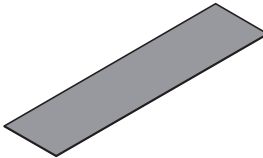
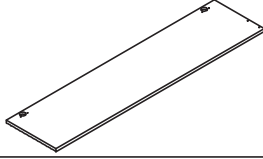



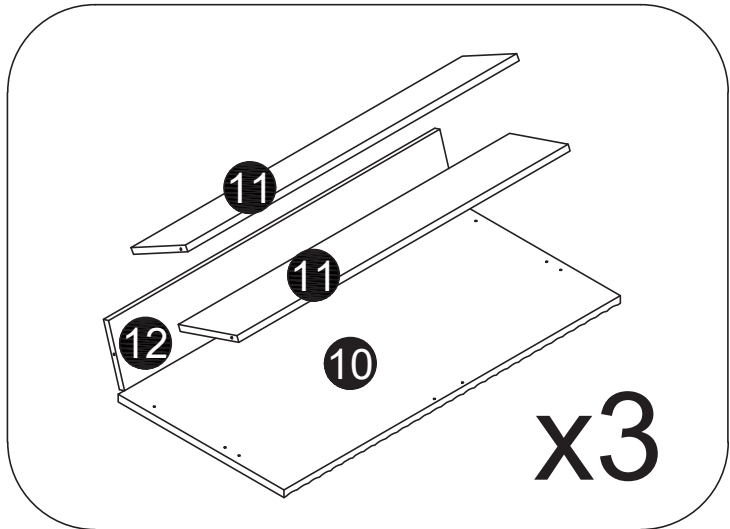
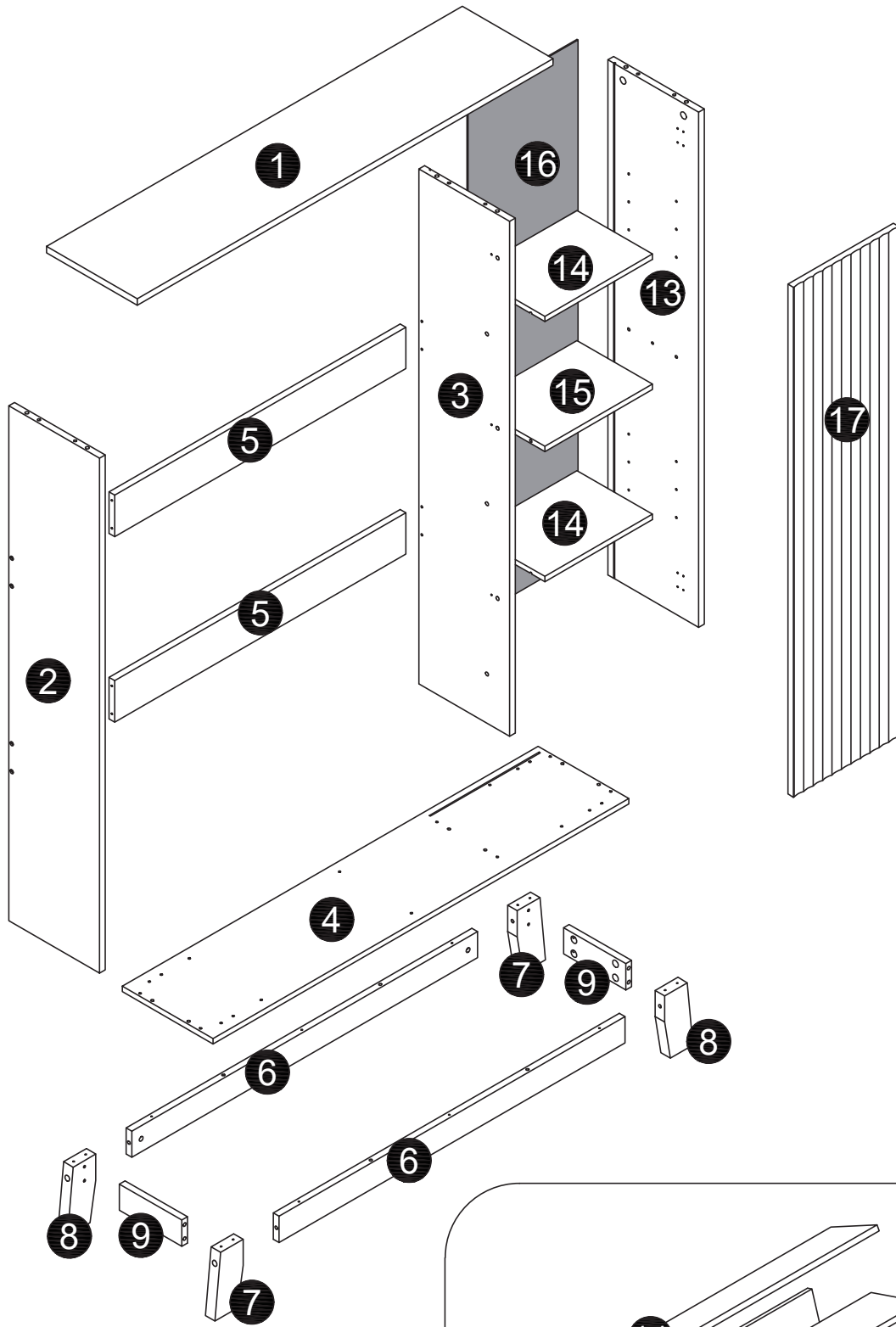



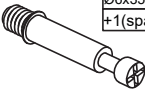

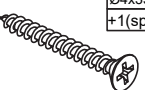







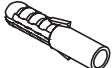

PACKING DETAILS

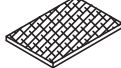
NO.	PARTS	QTY	SPARE
①		x1	
②		x1	
③		x1	
④		x1	
⑤		x2	
⑥		x2	
⑦		x2	
⑧		x2	
⑨		x2	
⑩		x3	
⑪		x6	

NO.	PARTS	QTY	SPARE
⑫		x3	
⑬		x1	
⑭		x2	
⑮		x1	
⑯		x1	
⑰		x1	
	 Hardware Kit	x1	

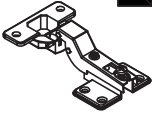

HARDWARE

 <p>A x16 Ø6x35mm +1(spare)</p>	 <p>B x16 Ø15x10mm +1(spare)</p>	 <p>C x20 Ø6x30mm +2(spare)</p>	 <p>D x16 Ø4x35mm +1(spare)</p>	 <p>E x62 Ø3.5x12mm +5(spare)</p>	 <p>F x6</p>
 <p>G x6</p>	 <p>H x6</p>	 <p>I x4</p>	 <p>J x4</p>	 <p>K x4</p>	 <p>L x3</p>
  <p>M x2 Ø4x14mm</p> <p>M-1 M-2</p>	 <p>N x2 Ø6x30mm</p>	 <p>O x8 15mm +2(spare)</p>	 <p>P x4</p>	 <p>Q x14 Ø4x30mm +1(spare)</p>	 <p>R x3</p>
 <p>S x1 M5</p>	  <p>T x6 Ø3x16mm +1(spare)</p> <p>T-1 T-2</p>	 <p>U x2</p>	 <p>V x8</p>		

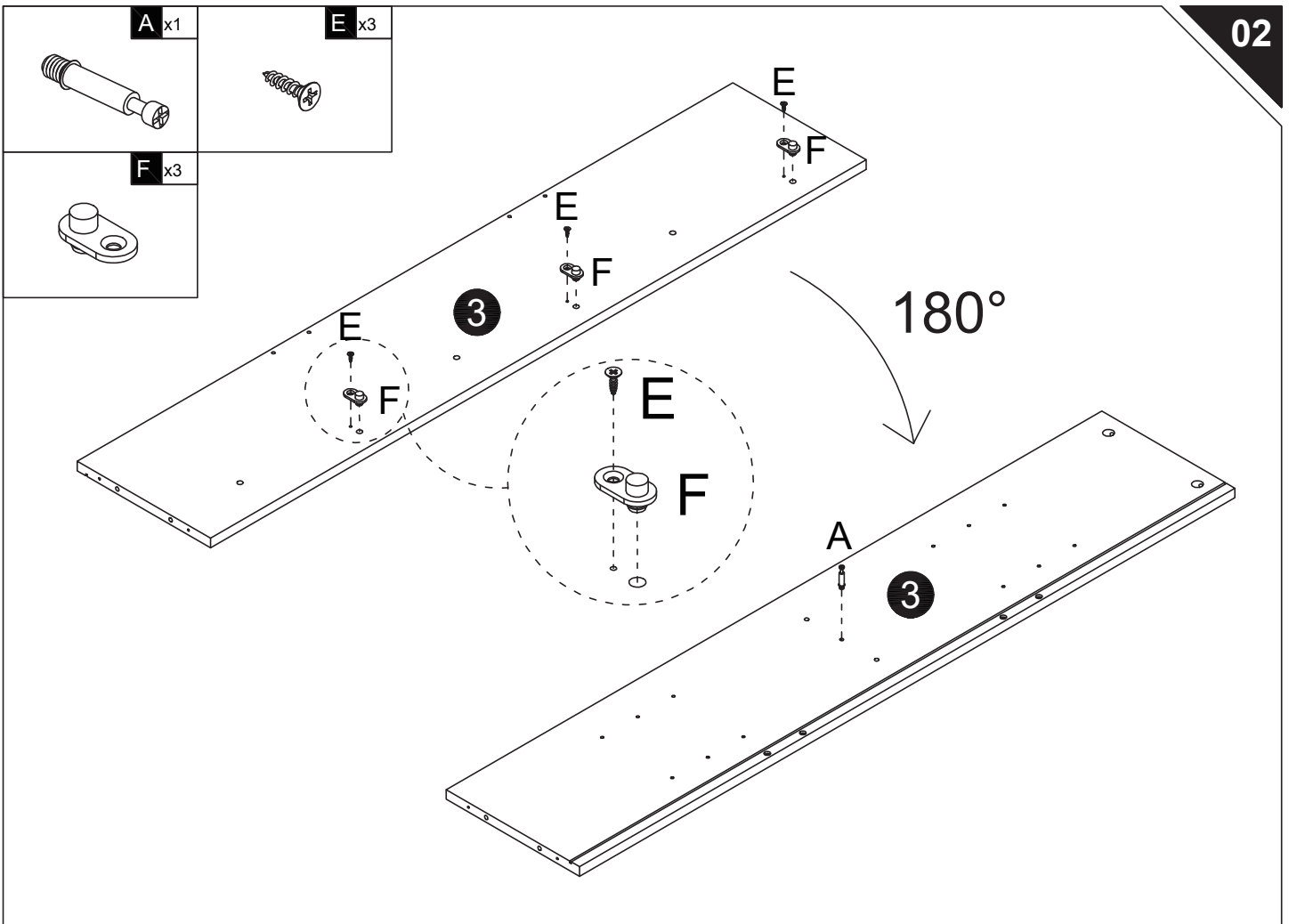
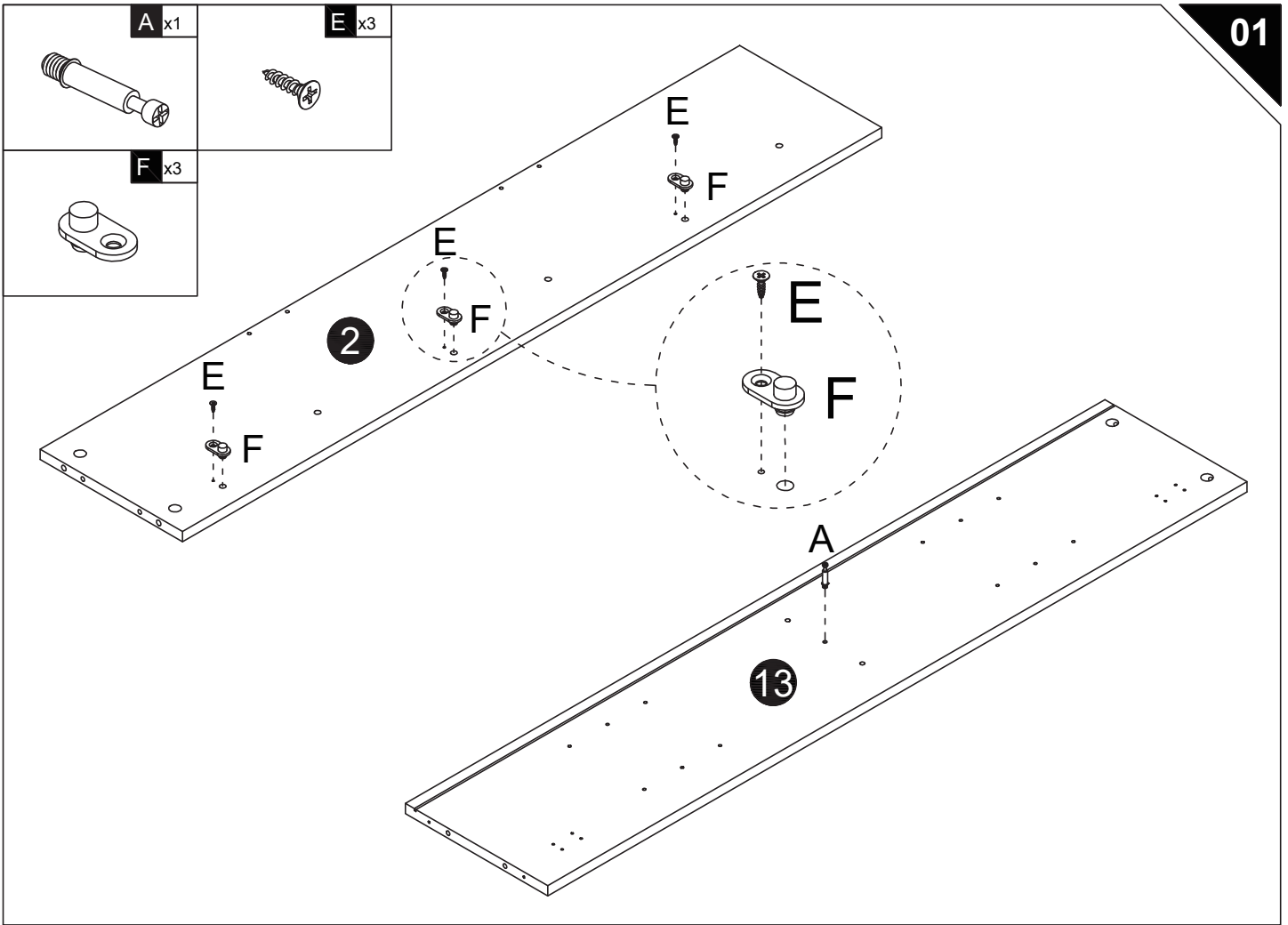

B x2

C x4

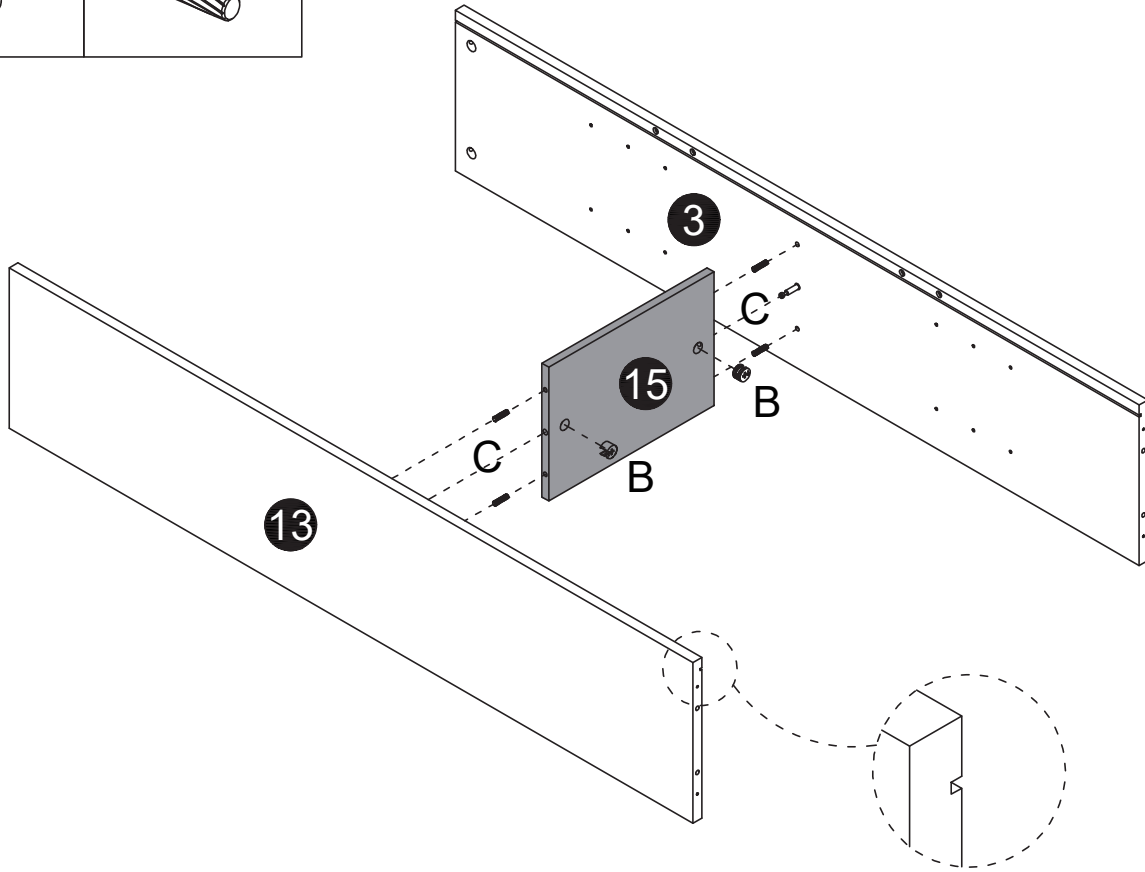

A x8

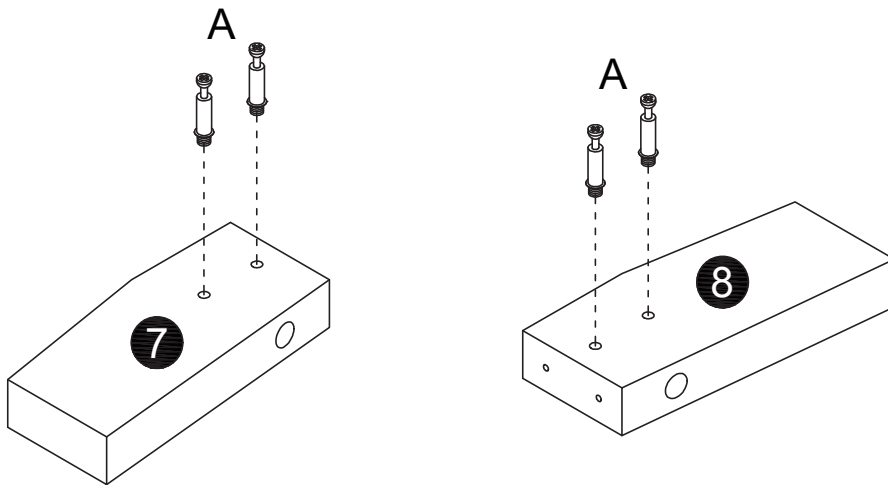
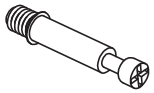

x2

B x8

P x4

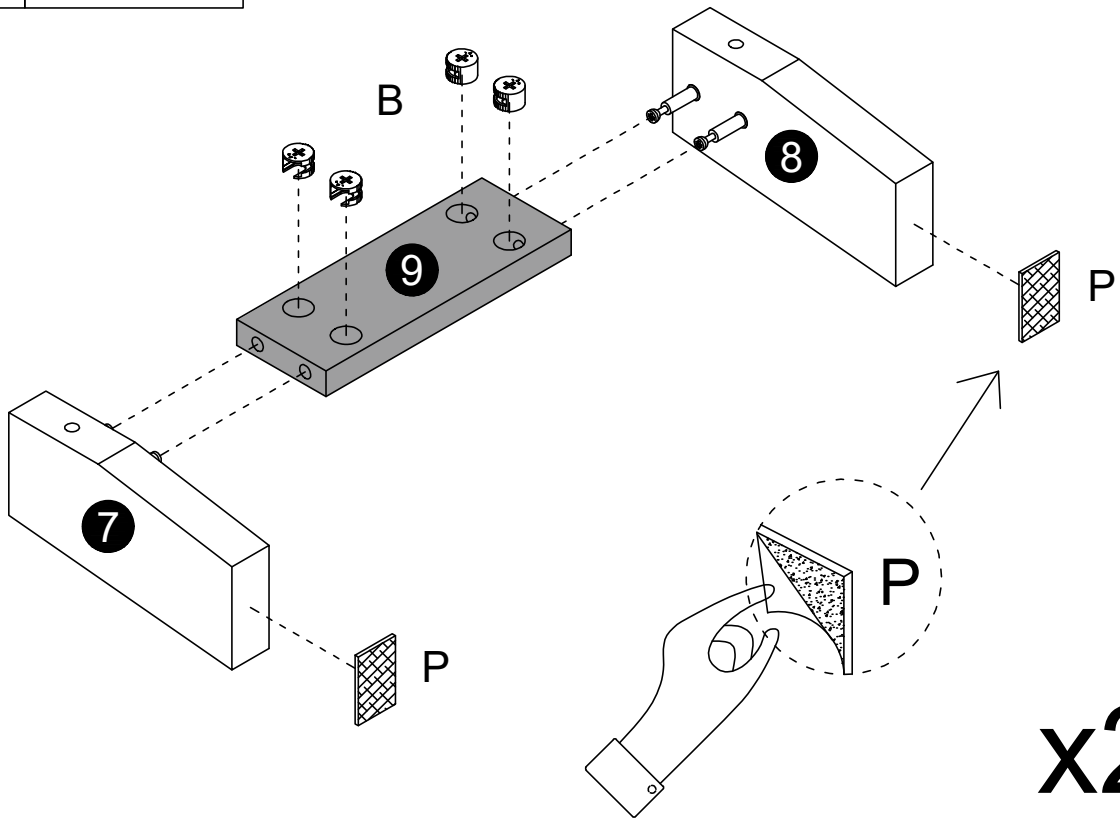
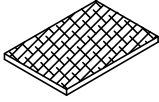

I x4

J x4

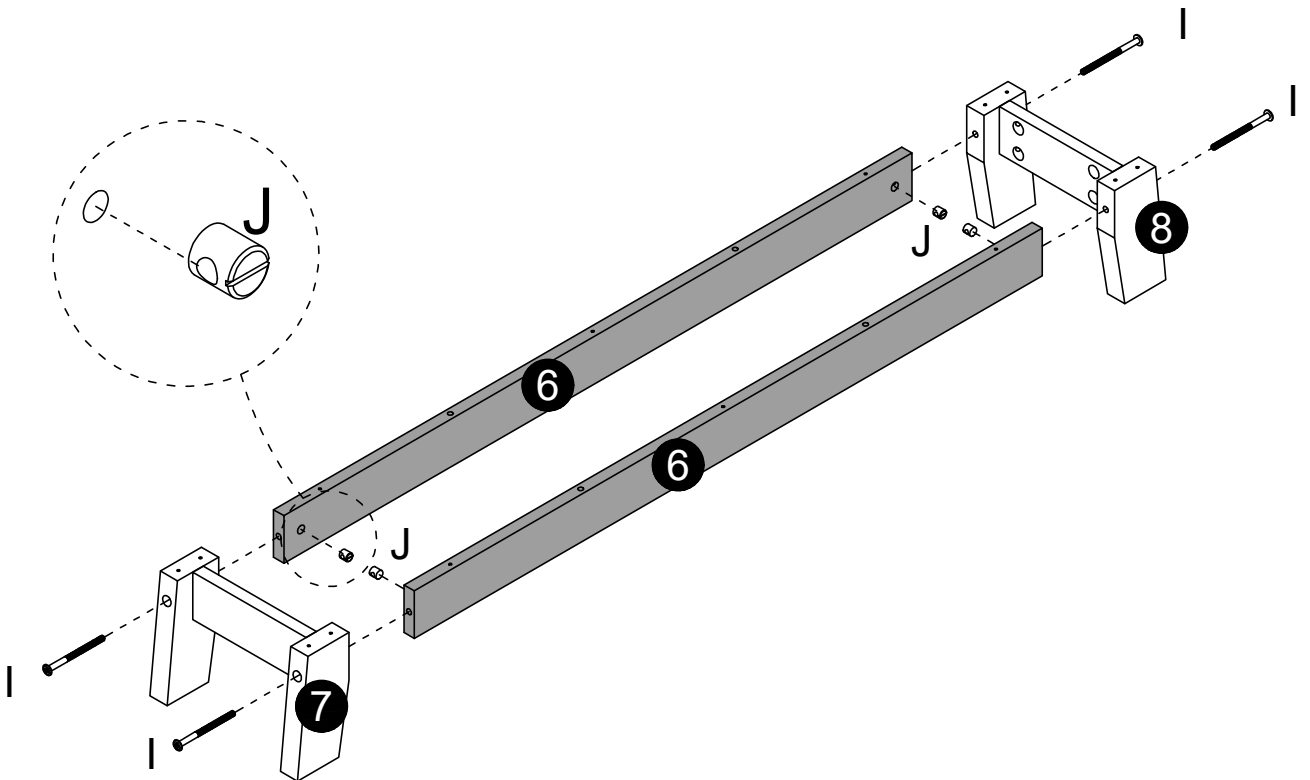

C x4

Q x14

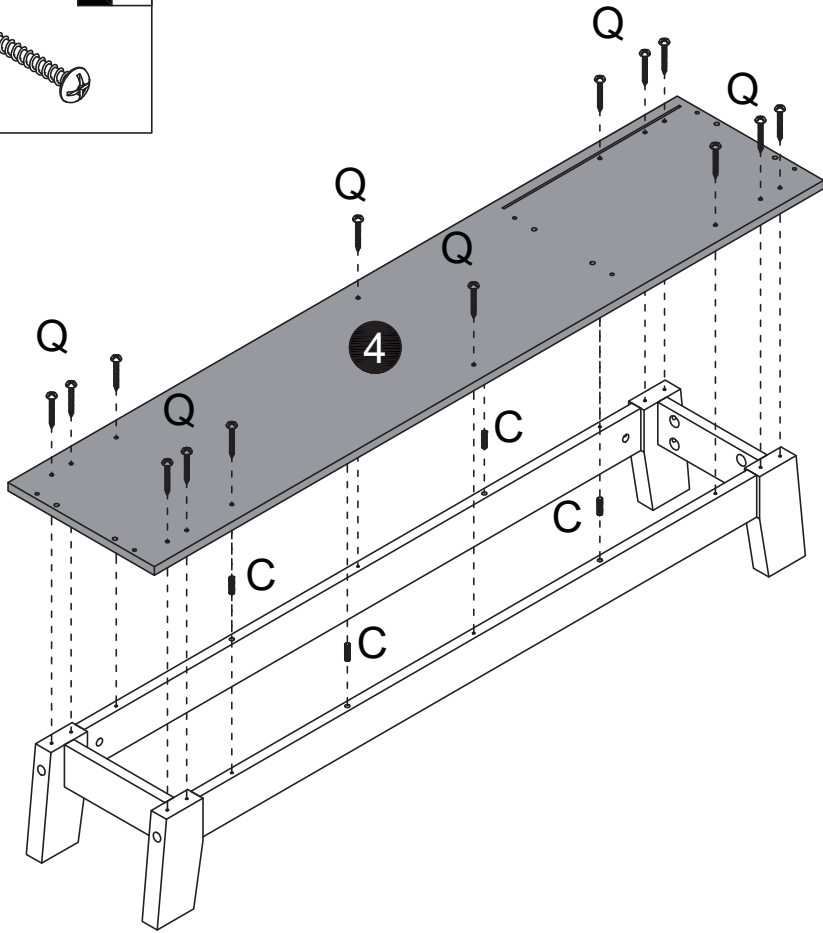
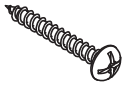

C x6

D x6

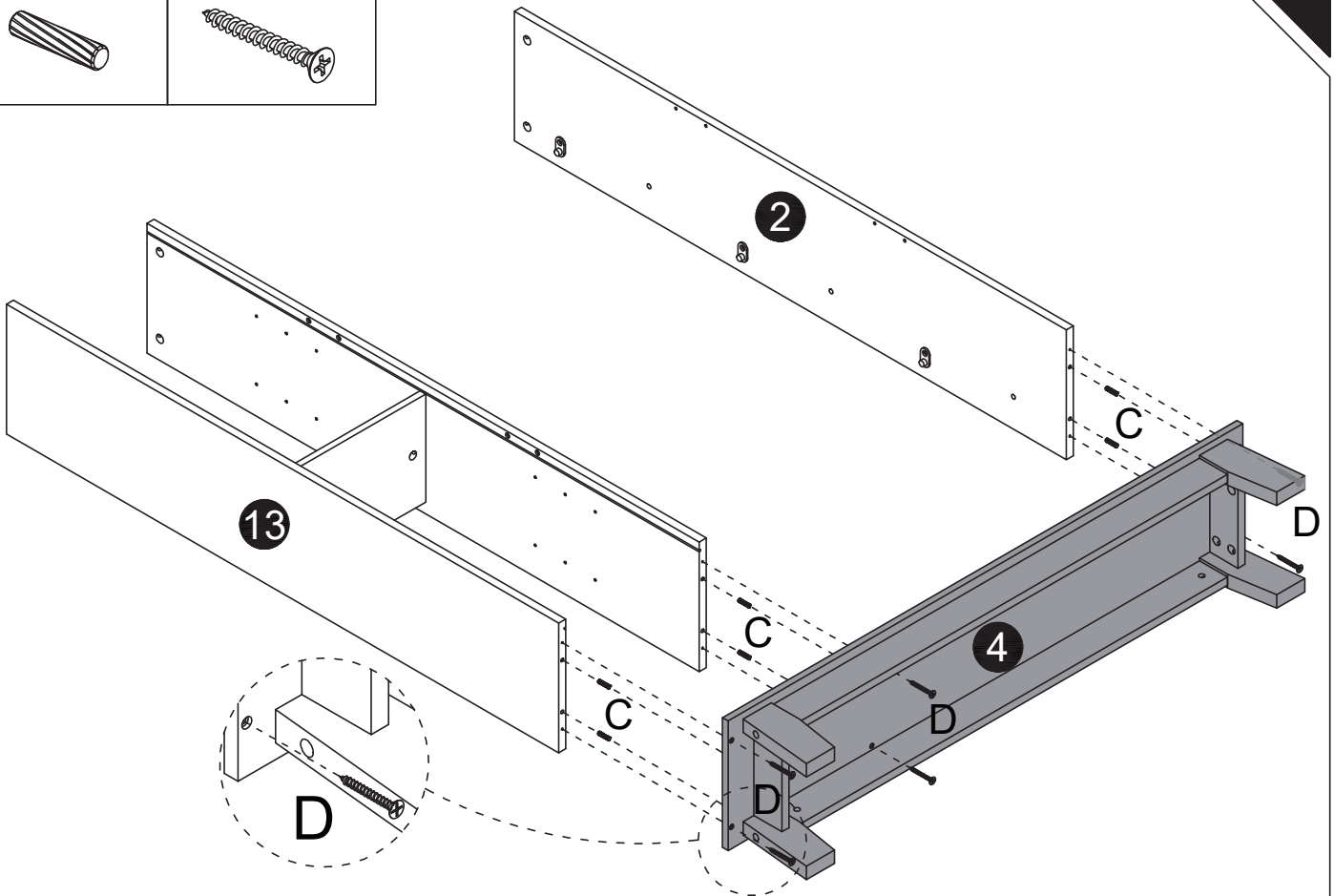
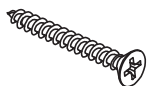

D x8

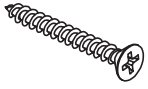

09

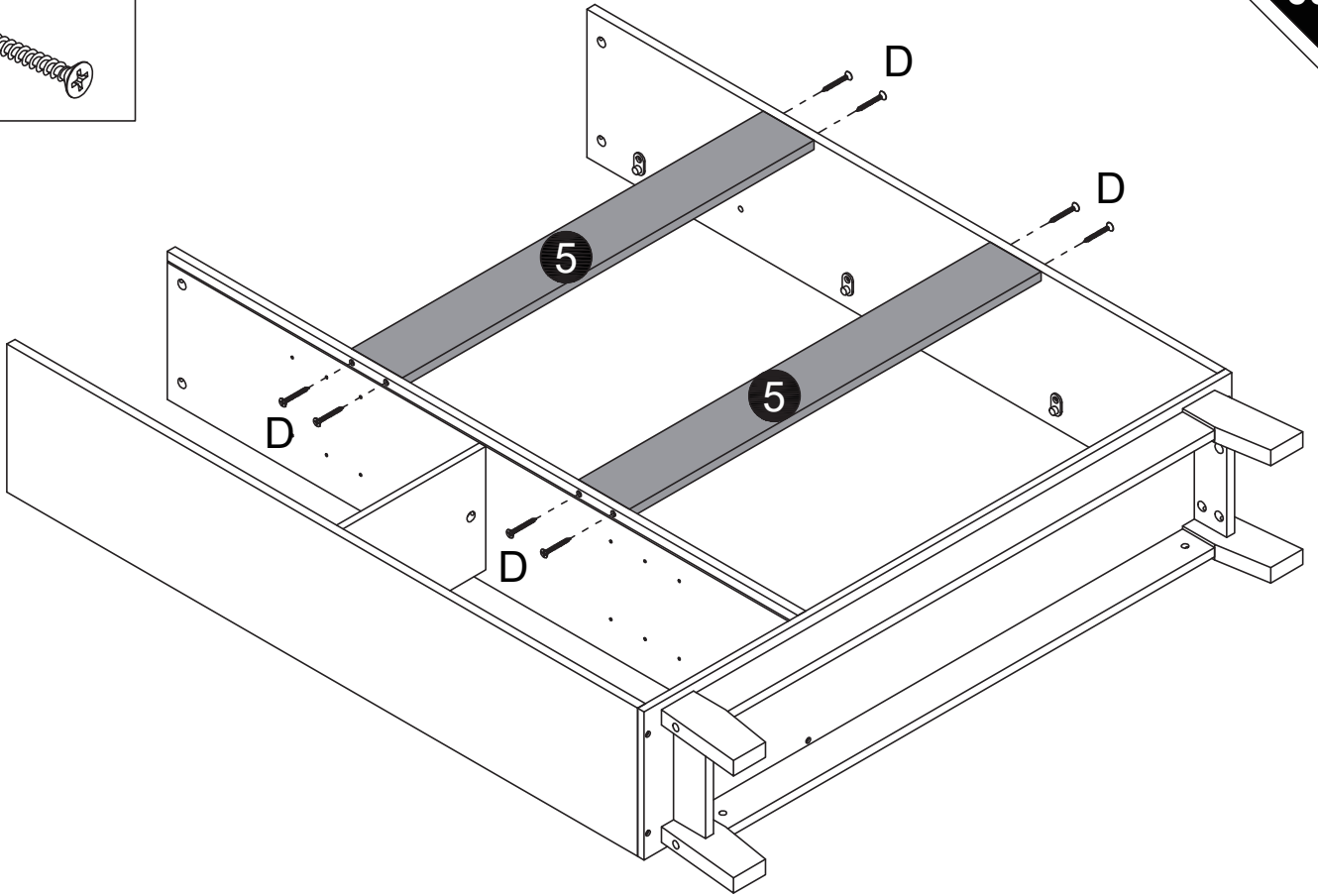

10

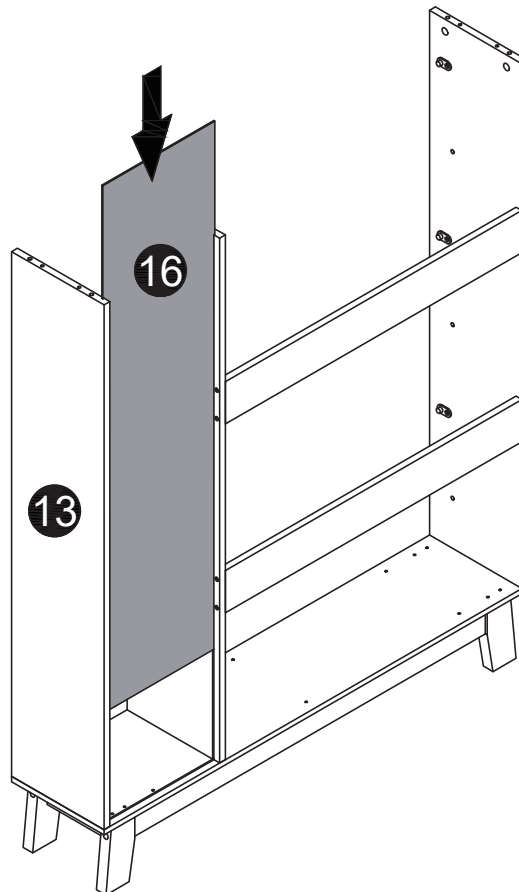

A x6

M x2

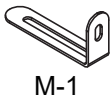
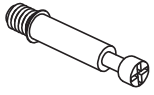

M-1

M-2

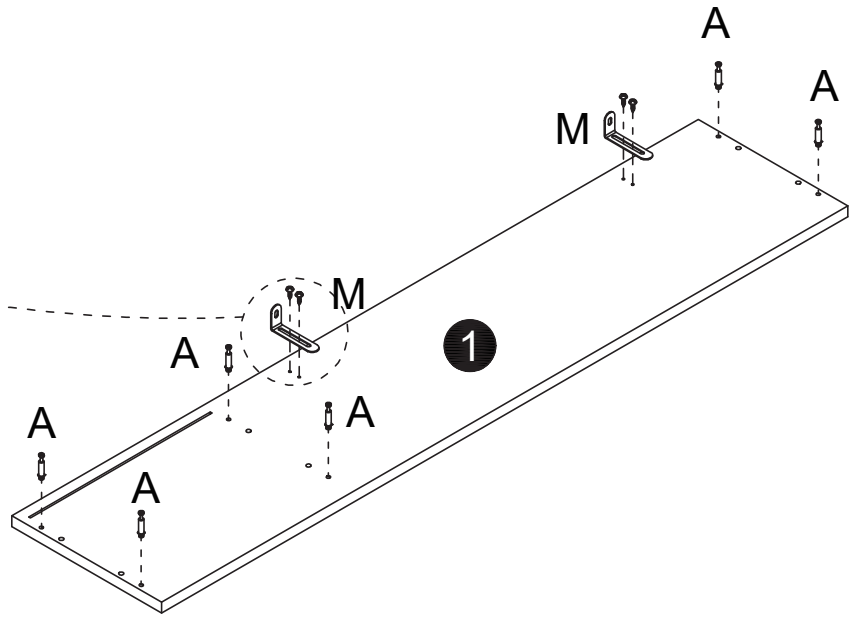
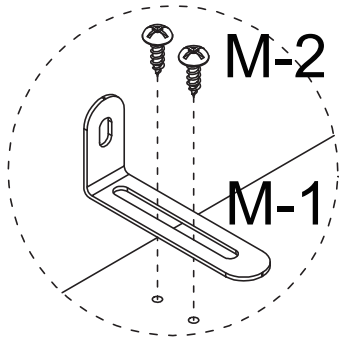

B x6

C x6

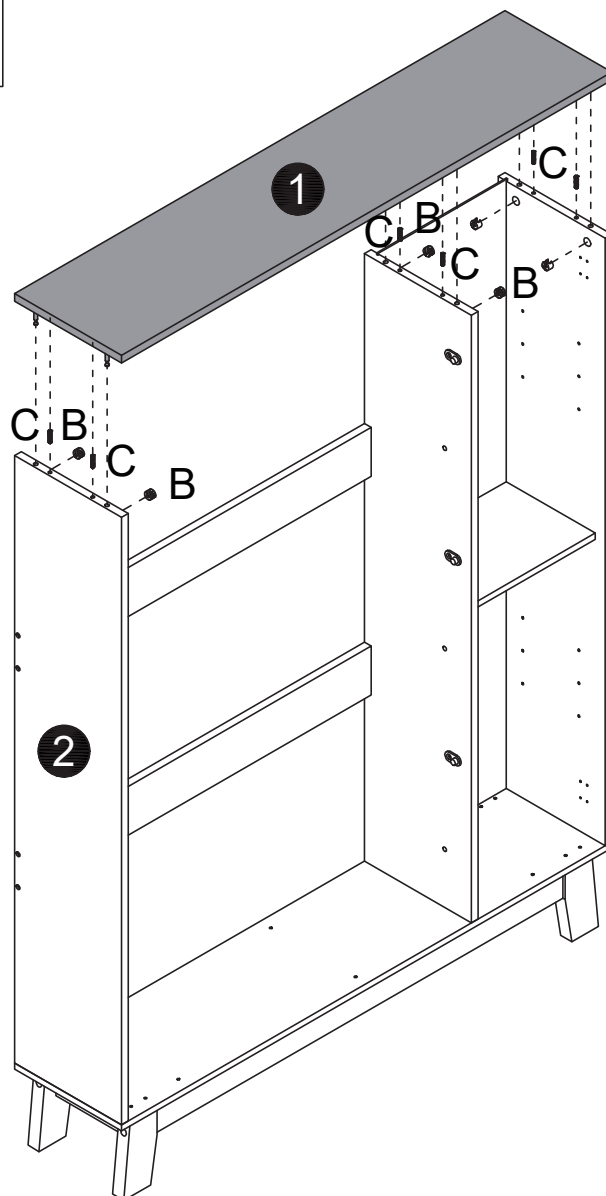

U x6



T-1 T-2

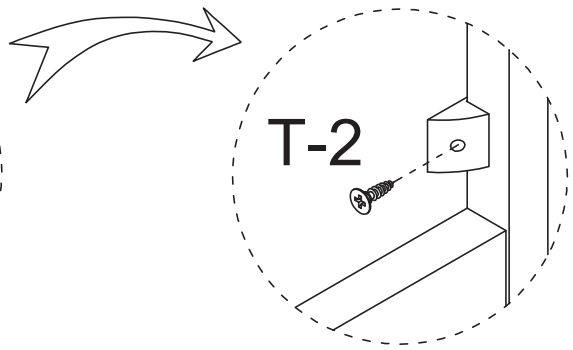
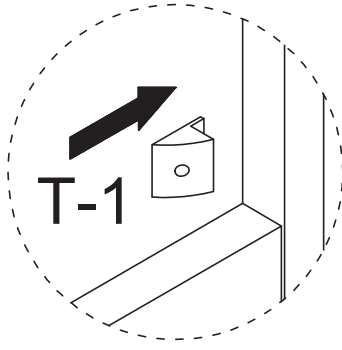
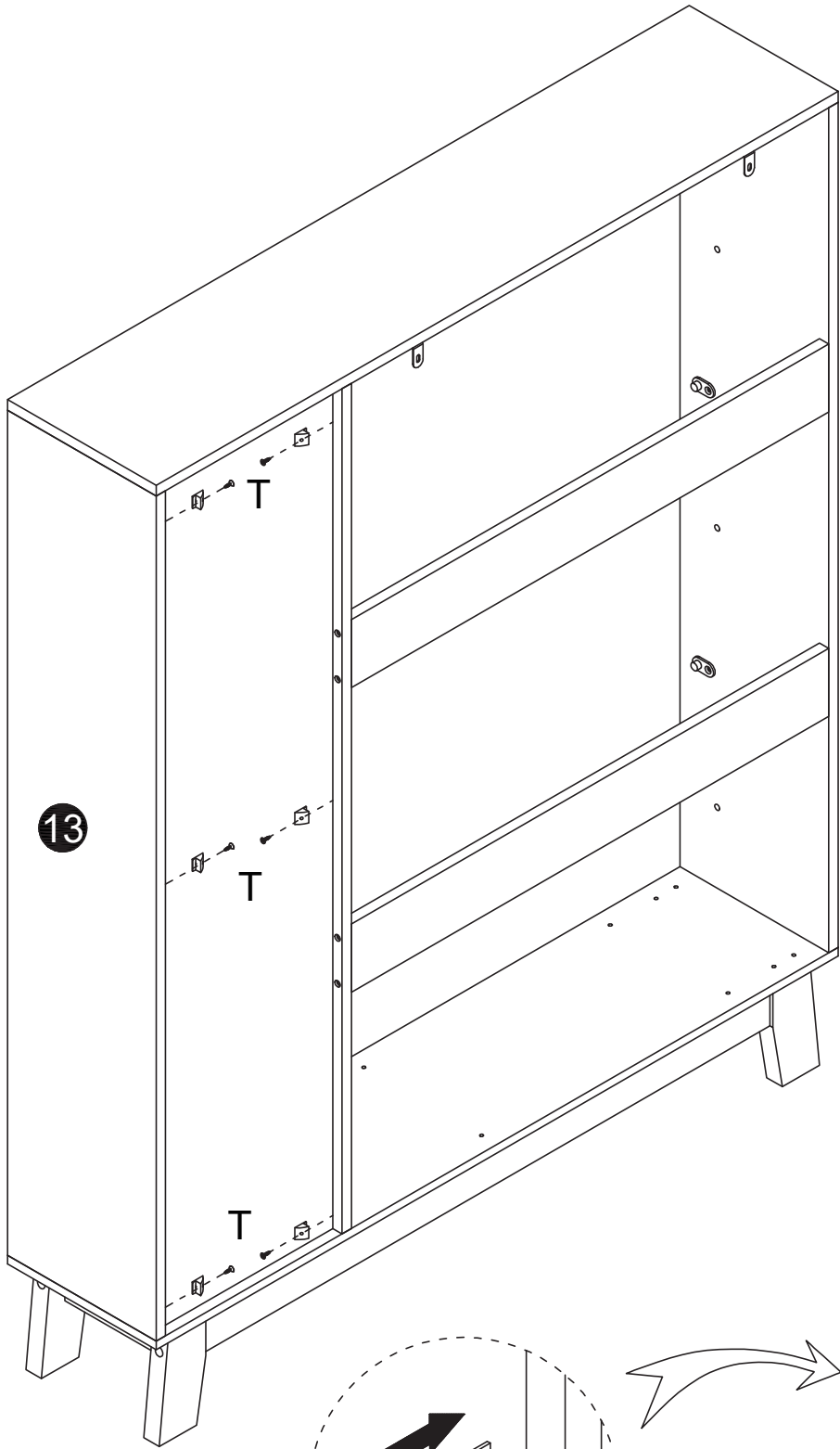

D x2

N x2

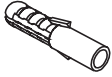
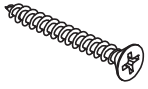

WALL

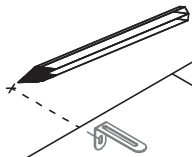

(1)x2

First, use a ruler to measure the approximate height of the product on the wall, and then mark it with a pen.

WALL

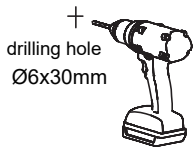

(2)x2

Then use a tape drill to make holes in the wall that are suitable for the product screws.

WALL

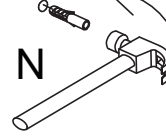

(3)x2

Then, put the expansion bolt into the hole

WALL

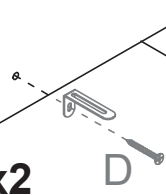

(4)x2

Finally, pass the matching screws through the "anti-rewind" and tighten them to fix them on the wall.

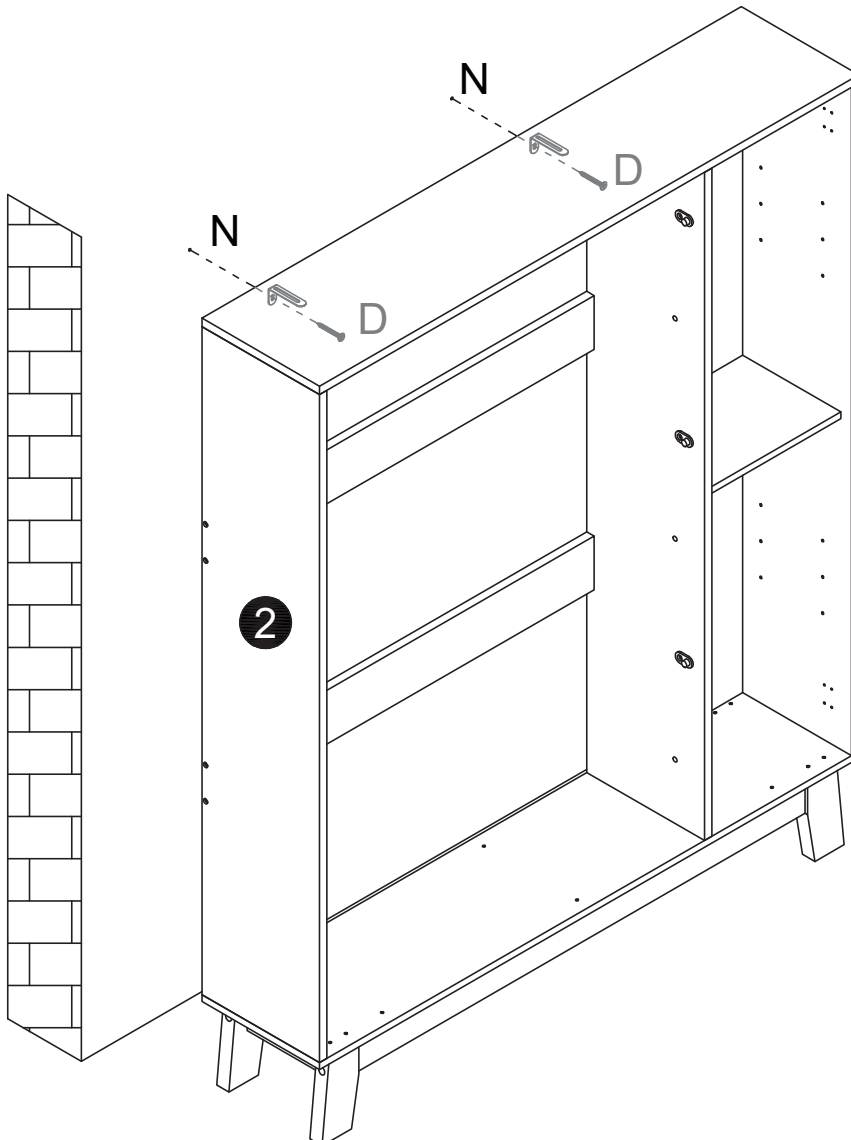

E x36

K x3

L x3

R x3

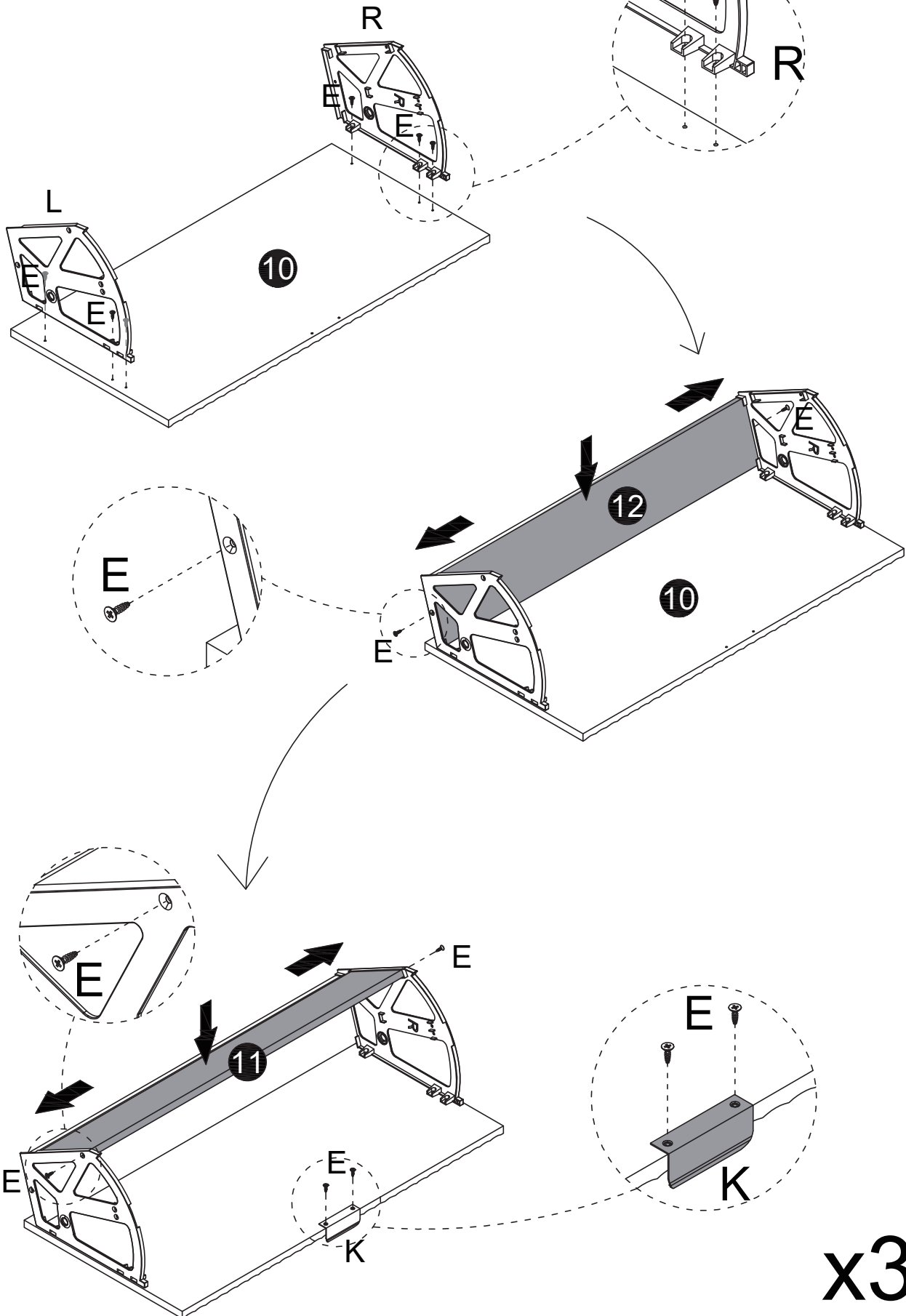
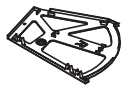

x3

G x6



H x6



S x1

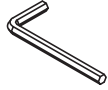

Please do not forcefully lock the installation screws to the maximum limit to avoid damaging the side panel.

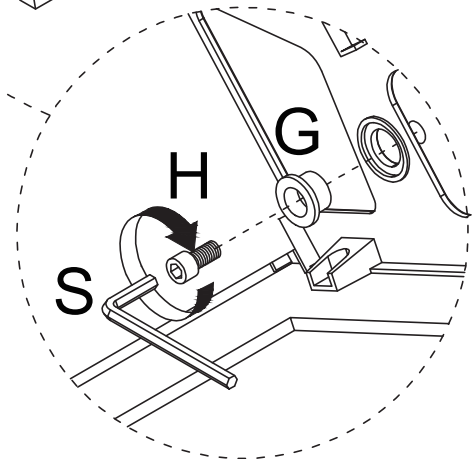
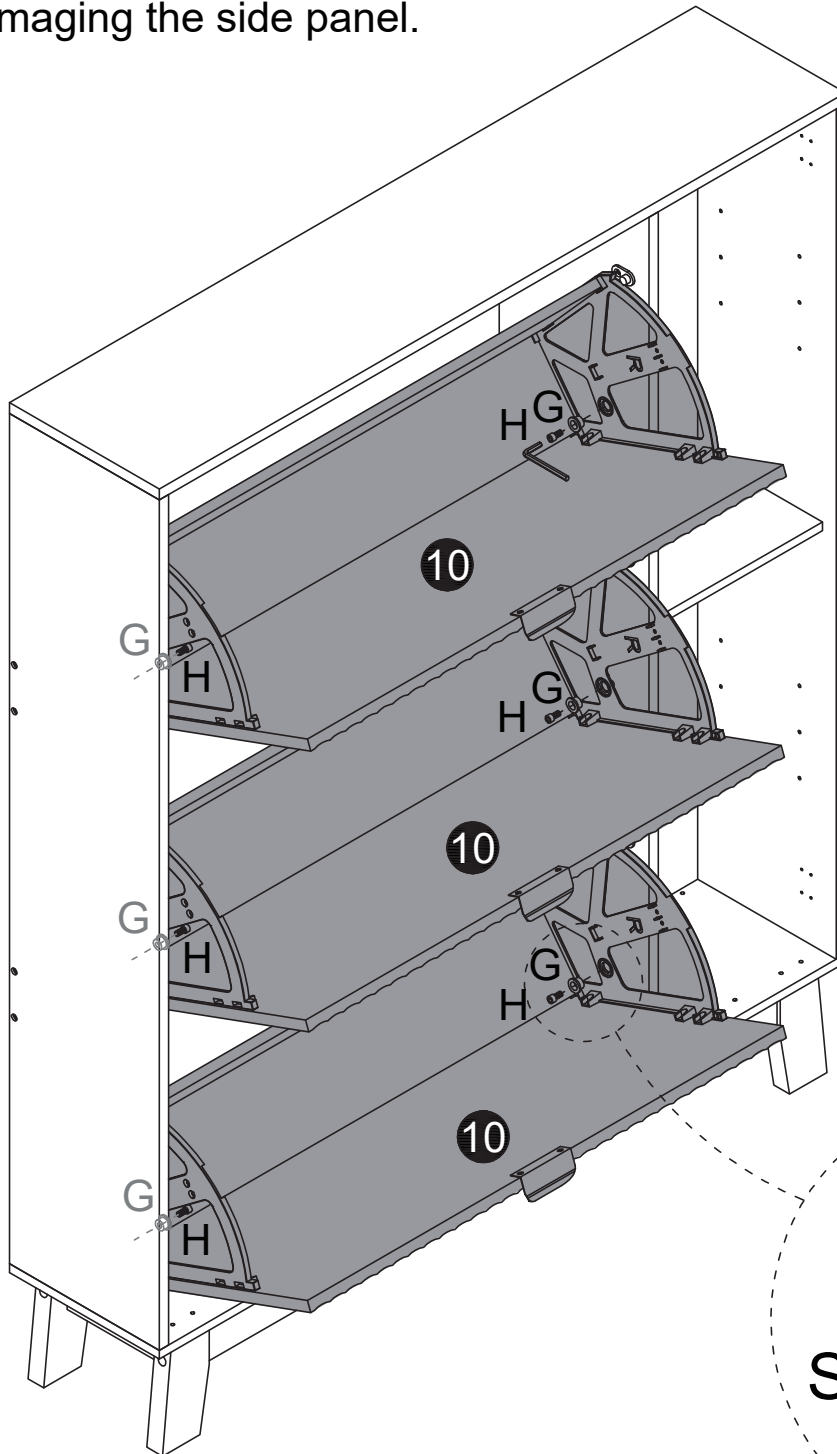
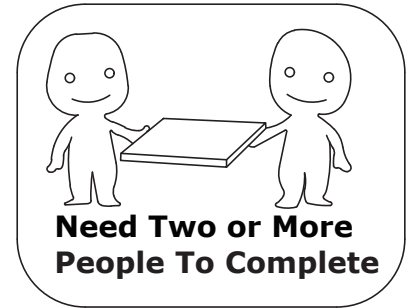

E x6

17

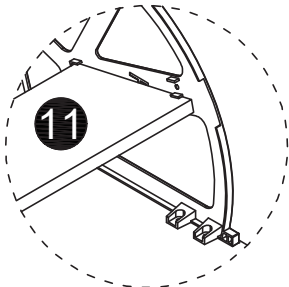

OR

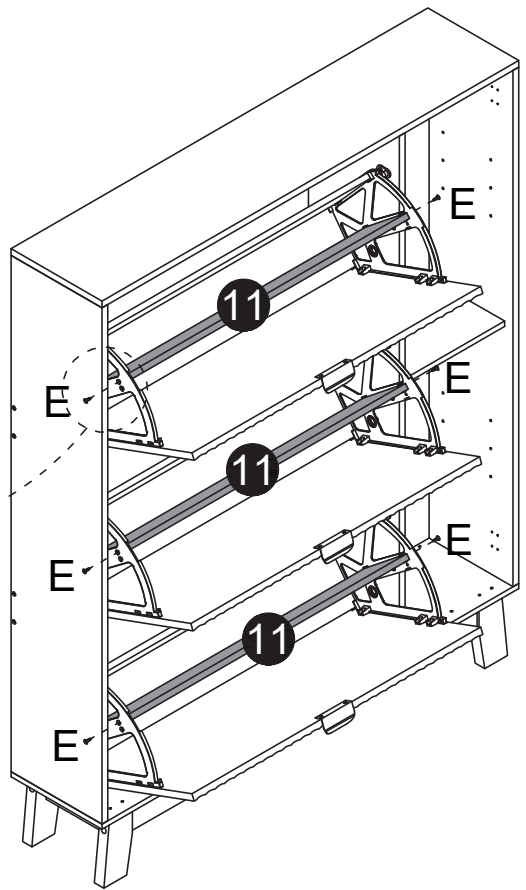
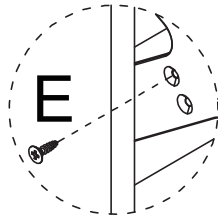
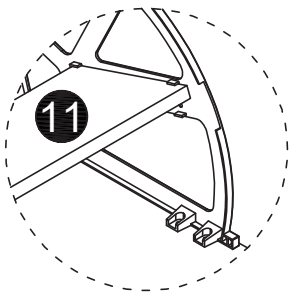

V x8

18

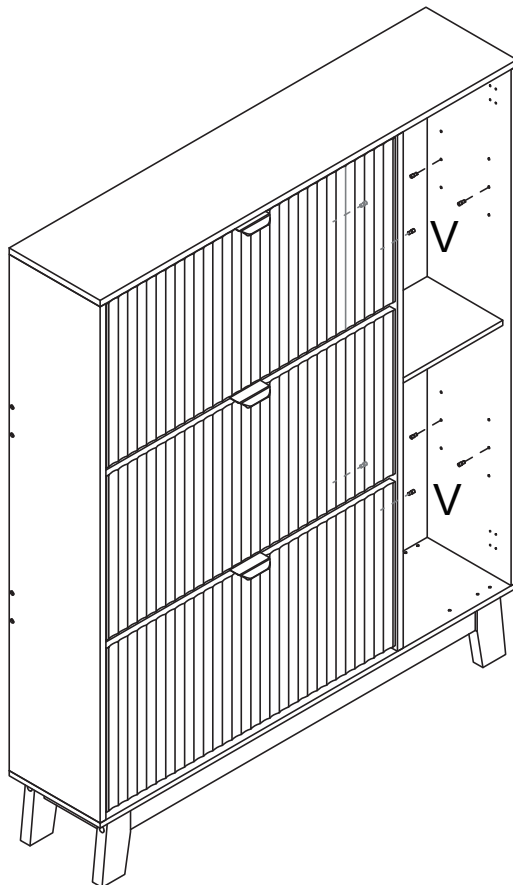

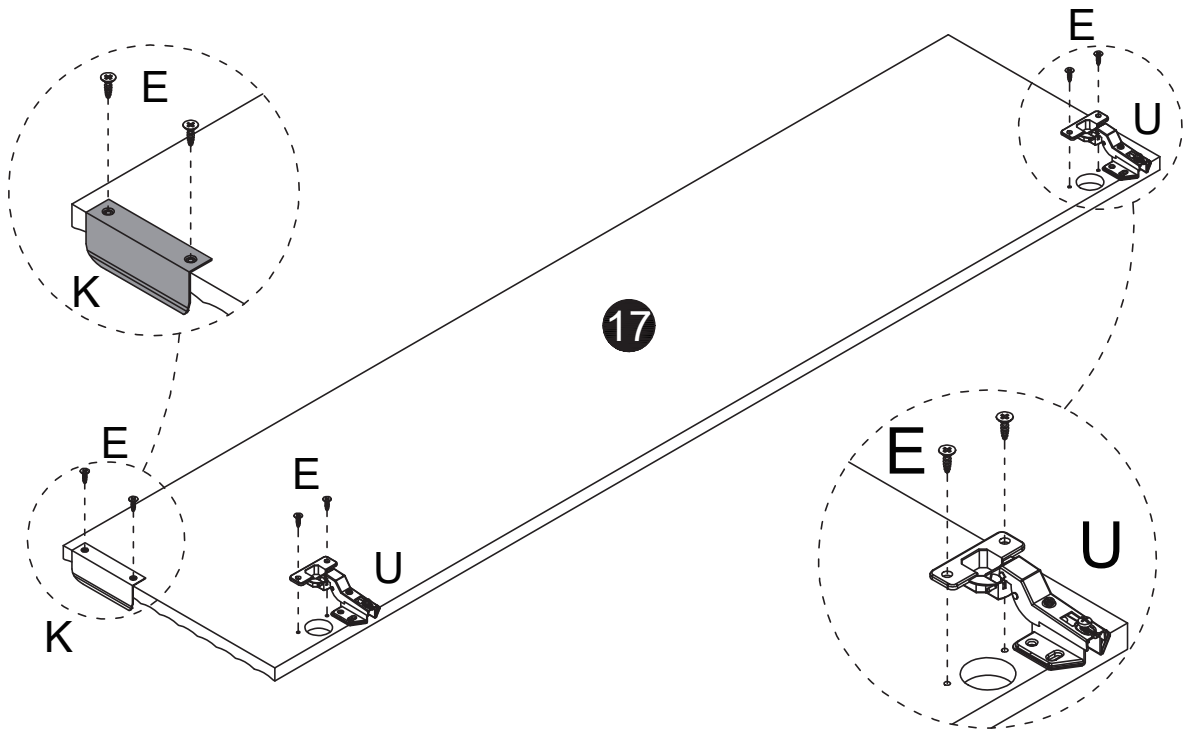
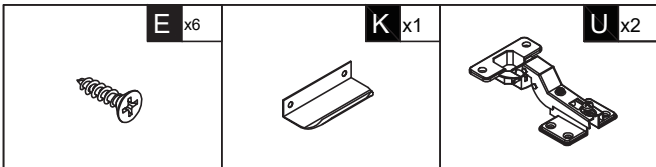
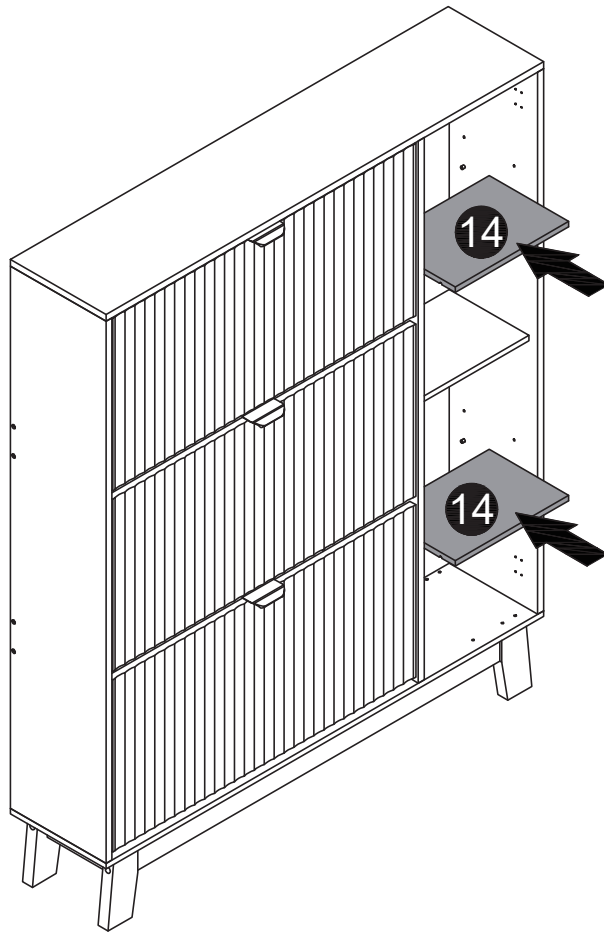

E x8

O x8

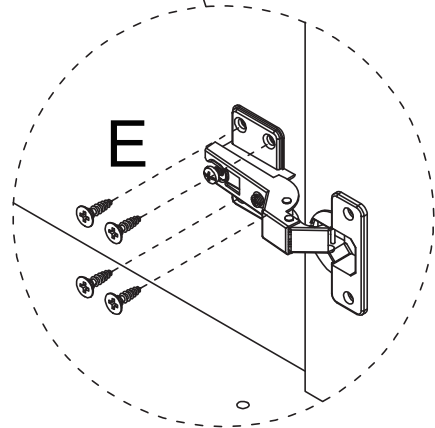
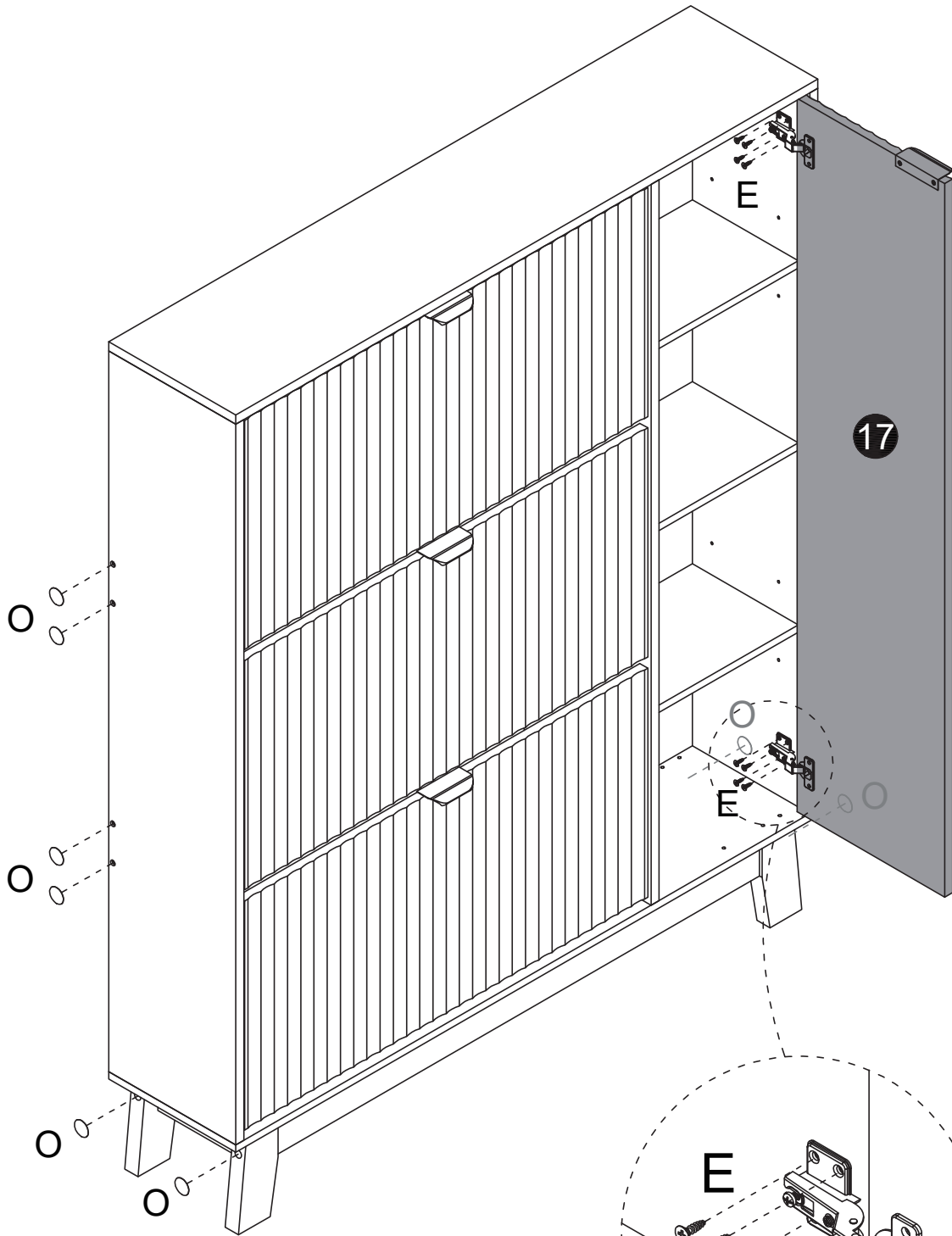

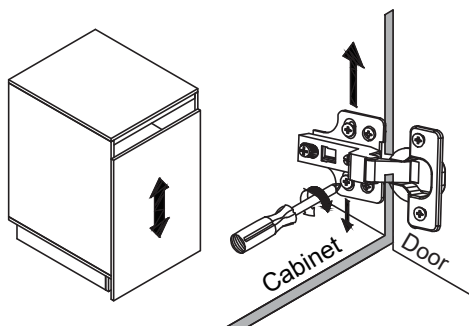
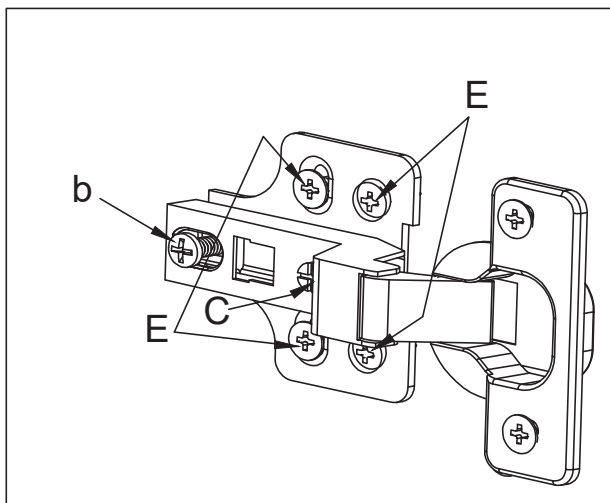
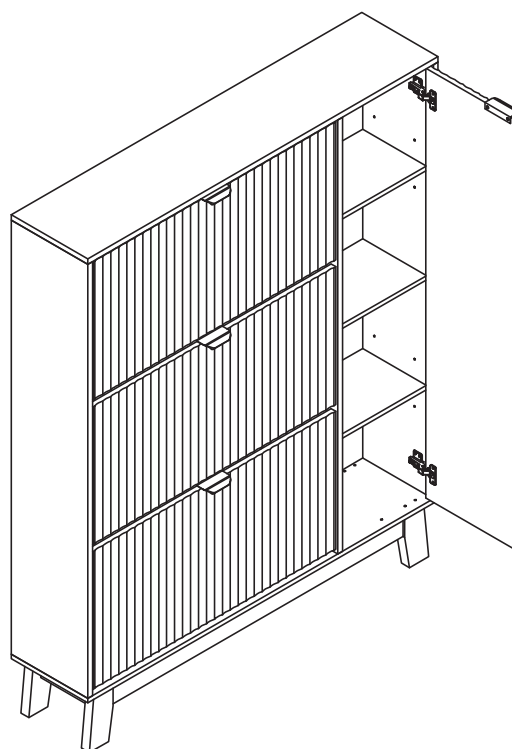

To adjust the vertical height.

Loosen the four screws "E" on both hinges. Two of them are usually in slotted holes which allows you to adjust up or down by a few mm. Then tighten back up.

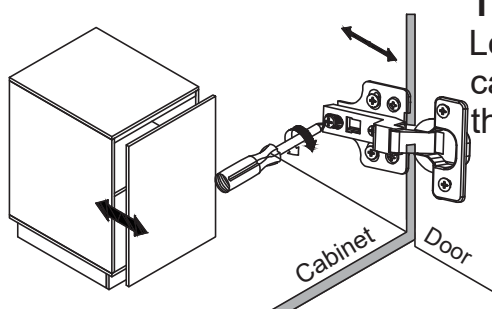

To adjust depth.

Loosen screw "b" and adjust door, if the door can not be adjusted, please loosen screw "c", then try again. Tighten screw "b" and "c".

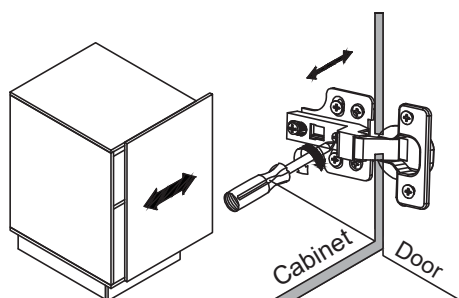

To adjust side ways.

Turning the screw "c" on BOTH hinges on each door.