

INSTRUCTION MANUAL



Chest of 3 Drawers

ASSEMBLY INSTRUCTIONS



- Carefully unpack all the components and verify that all the necessary parts are included as listed in the packaging.
- Identify each component and refer to the provided assembly diagram or step-by-step instructions.
- Assemble the furniture in the order specified to ensure proper alignment and fit.
- Use the provided tools or recommended tools for assembly. Do not use excessive force when tightening screws or bolts.
- If any difficulties arise during assembly, consult the troubleshooting section or contact our customer support.

TOOLS REQUIRED

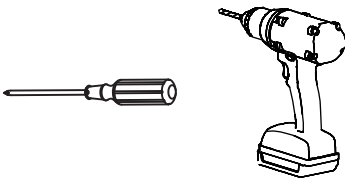

HARDWARE

A M6x35mm Bolt

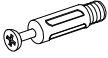

43PCS

B M15x10mm Eccentric Wheel



43PCS

C M8x30mm Wooden Dowel



22PCS

D M3x12mm Screw



24PCS

E M4x30mm Screw



27PCS

F M4x16mm Screw



3PCS

G Handle



3PCS

H Back Panel Fastener



8PCS

I M3x16mm Screw



8PCS

J Washer



2PCS

K Plastic Expansion



1PCS

L Anti-tipping Strap



1PCS

M M4x14mm Screw



17PCS

N M4x35mm Screw



3PCS

O 300mm Cabinet Slider



6PCS

P 300mm Drawer Slider



6PCS

Q M4x50mm Screw



12PCS

R Screw Hole Cover



24PCS

S M6x20mm Screw

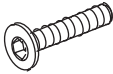

8PCS

T Allen Wrench

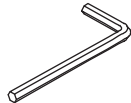

1PCS

U Iron Plate

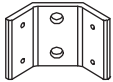

4PCS

V Foot Pad



4PCS

W Spring Washer



8PCS

PART

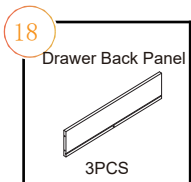
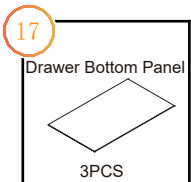
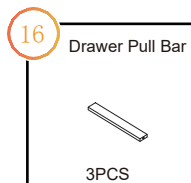
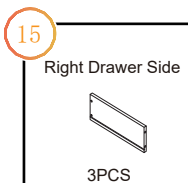
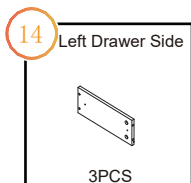
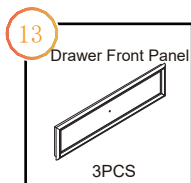
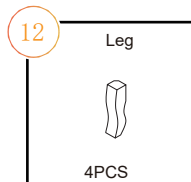
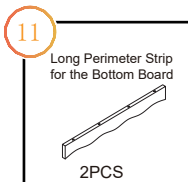
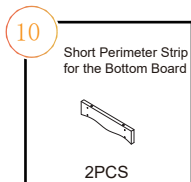
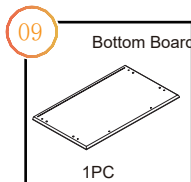
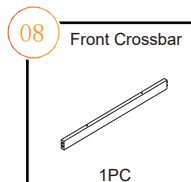
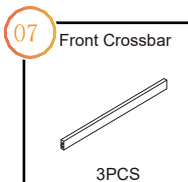
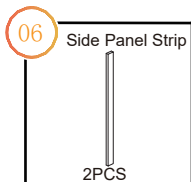
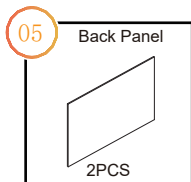
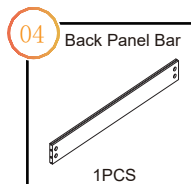
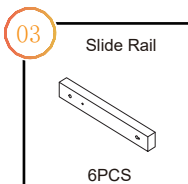
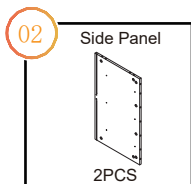
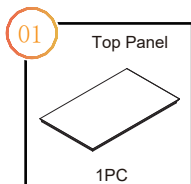

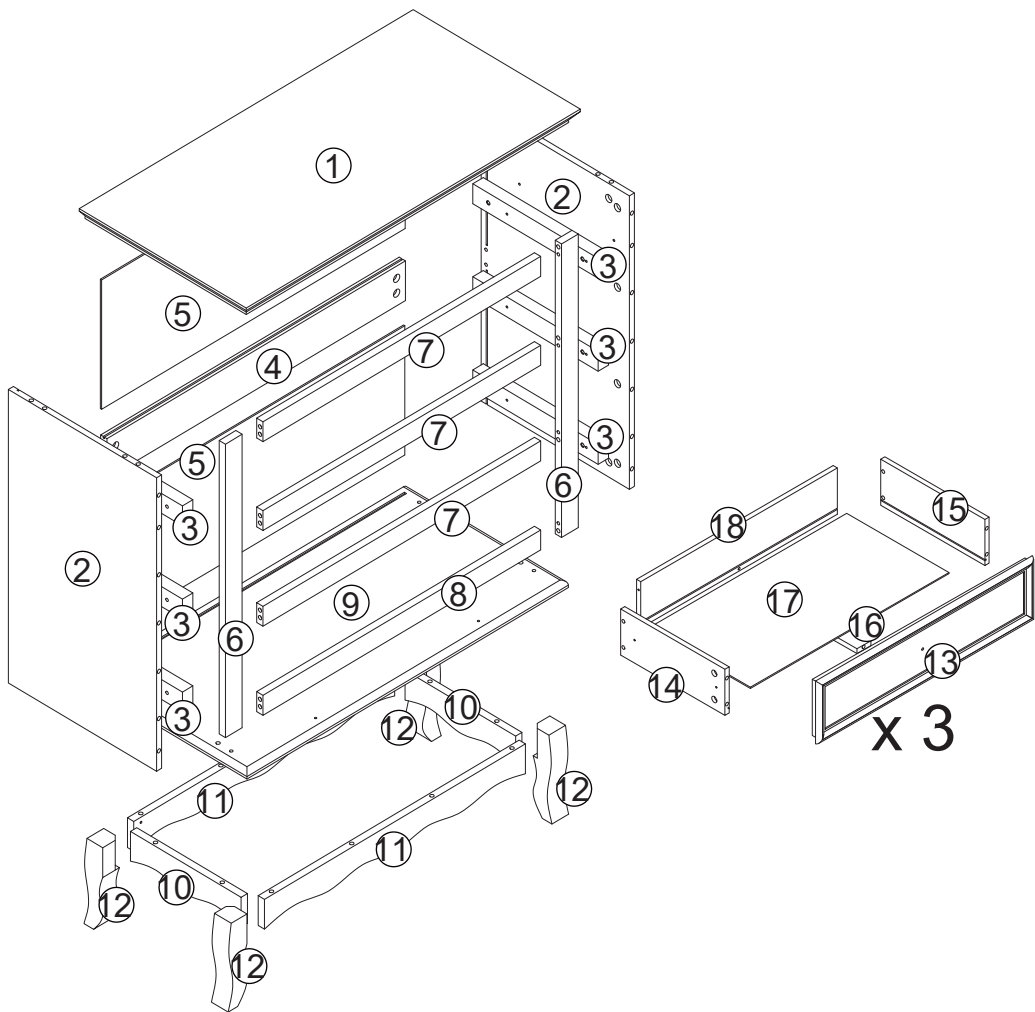

STEP 1

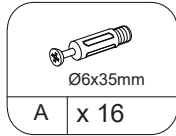
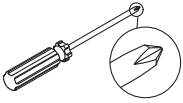

Secure screw A onto panel 6

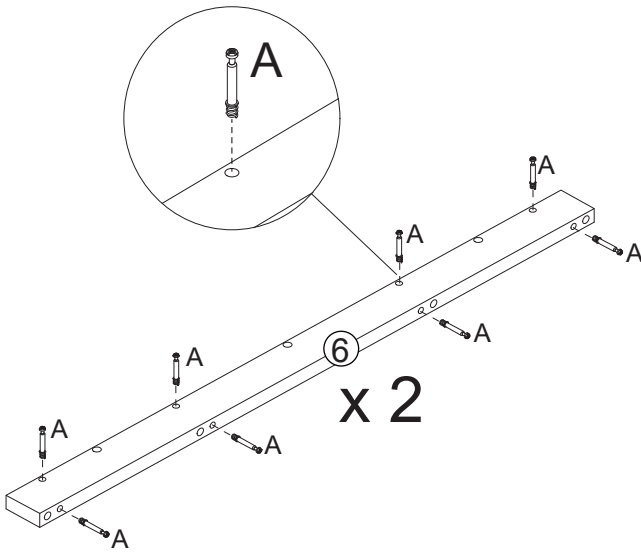

STEP 2

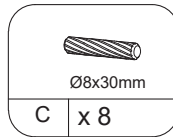
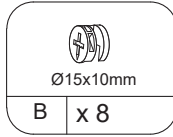
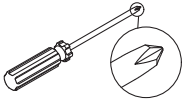

Connect panel 6 to panels 7 and 8 using wooden dowel C, then tighten eccentric wheel B clockwise while rotating

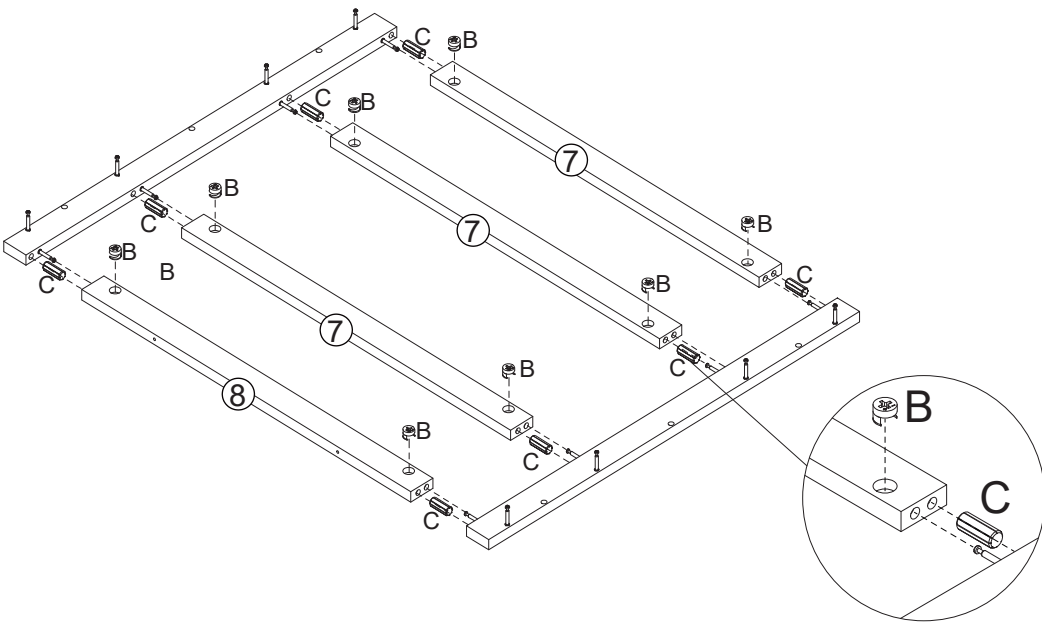

STEP 3

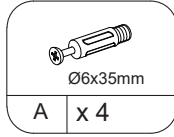
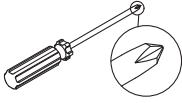

Secure screw A onto panel 2

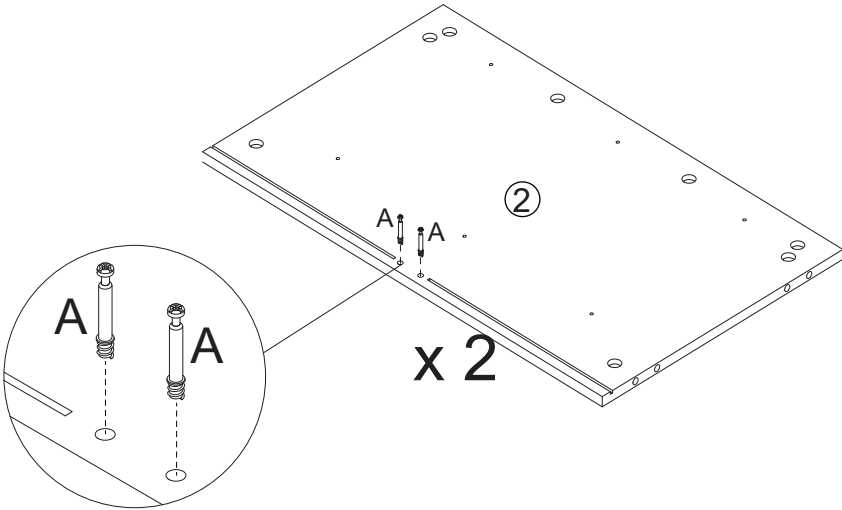

STEP 4

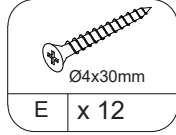
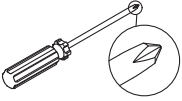

Attach panel 3 to panel 2 using screw E

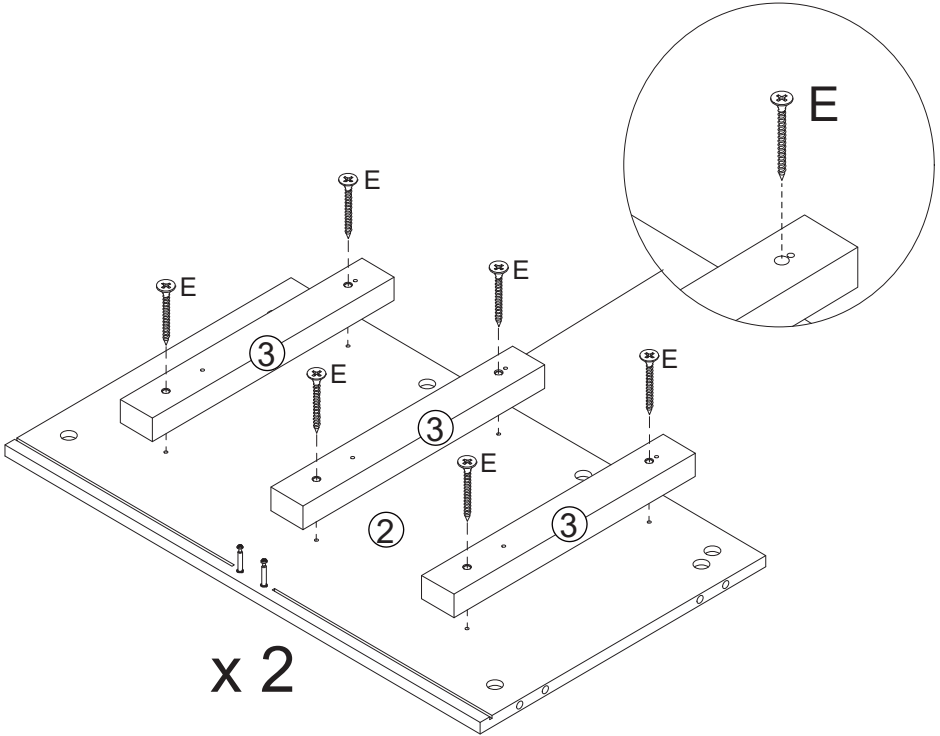

STEP 5

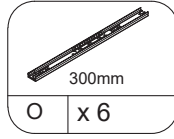
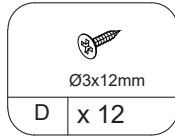
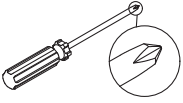

Secure cabinet slider O to panel 3 using screw D

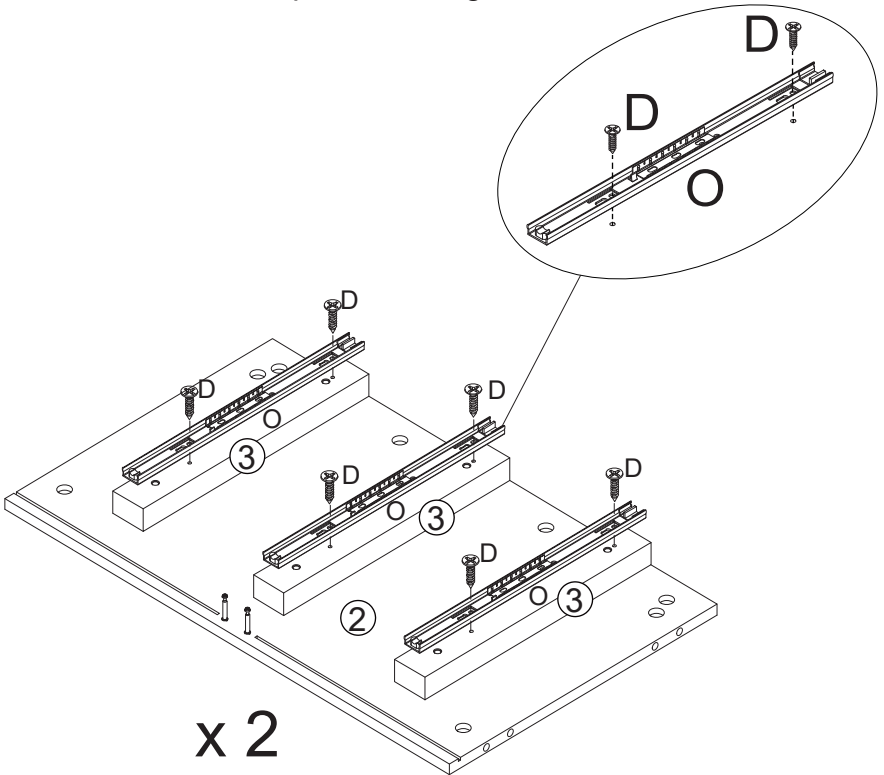

STEP 6

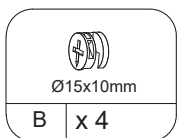
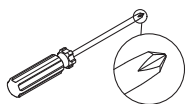

Connect panel 2 to panel 4, then tighten eccentric wheel B clockwise

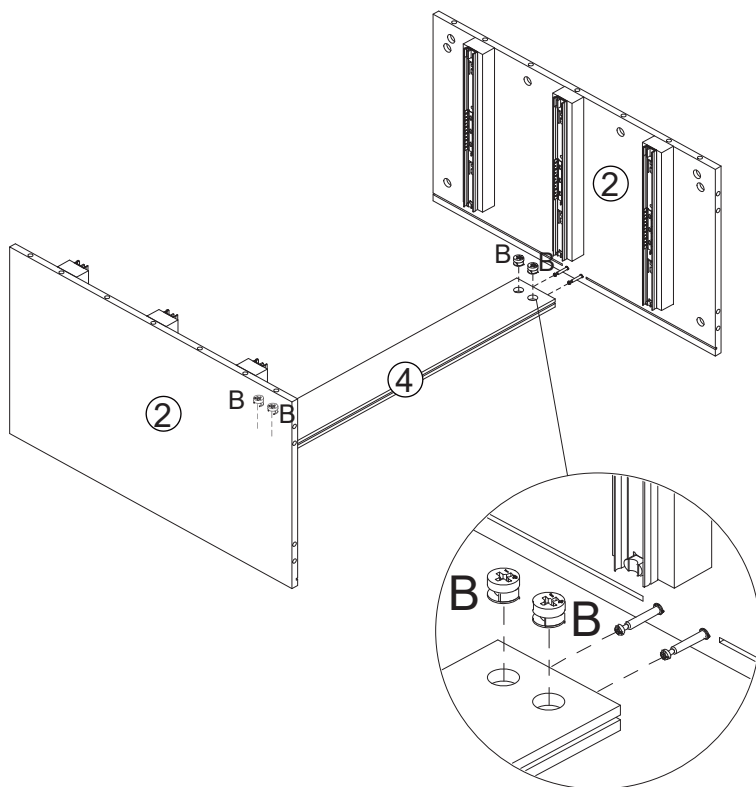

STEP 7

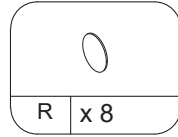
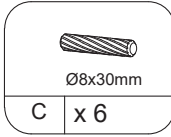
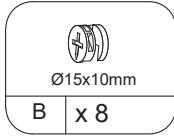
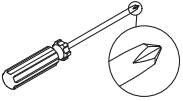

Connect the assembled components to panel 2 using wooden dowel C, then tighten eccentric wheel B clockwise
Finally, affix hole sticker R

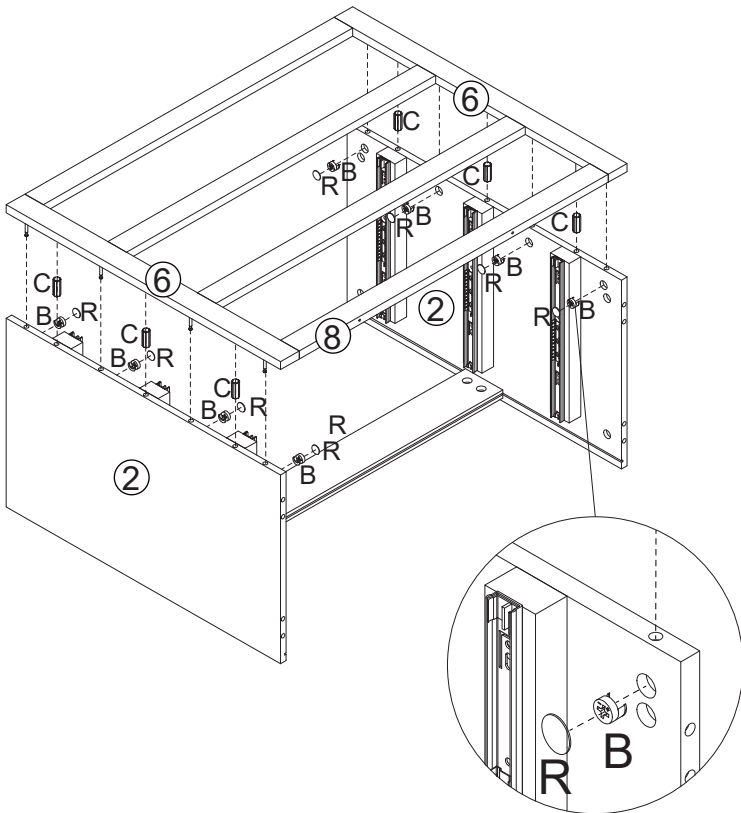

STEP 8

Slide back panel 5 into the assembled components

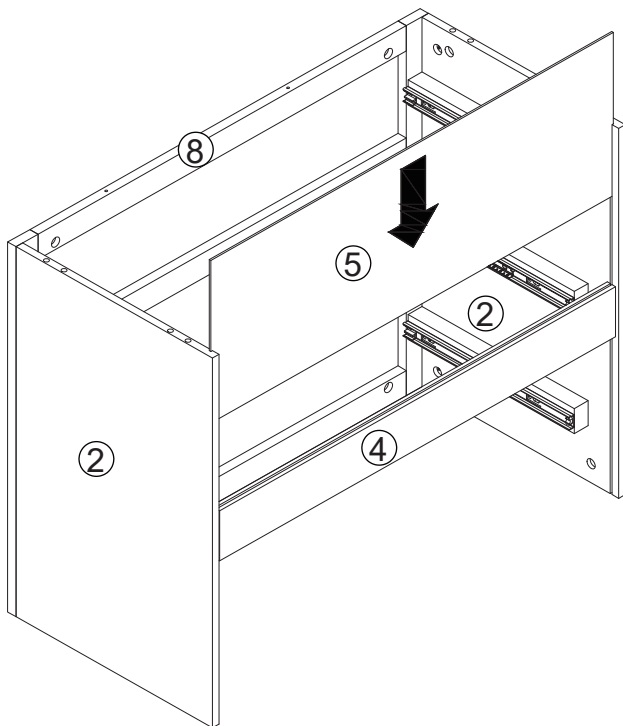

STEP 9

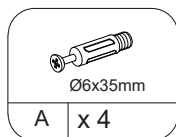
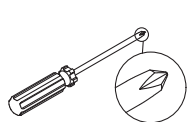

Secure screw A onto panel 9

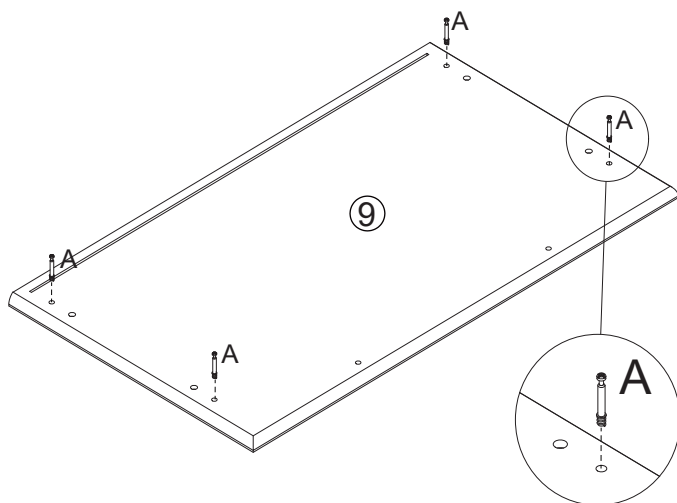

STEP 10

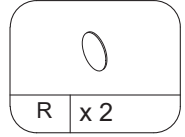
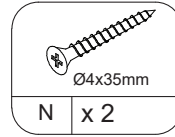
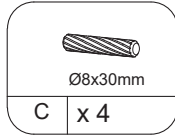
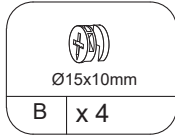
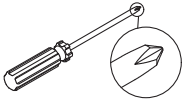

Connect panel 9 to panel 2 using wooden dowel C,
then tighten eccentric wheel B clockwise
Secure it with screw N, and finally, affix hole sticker R

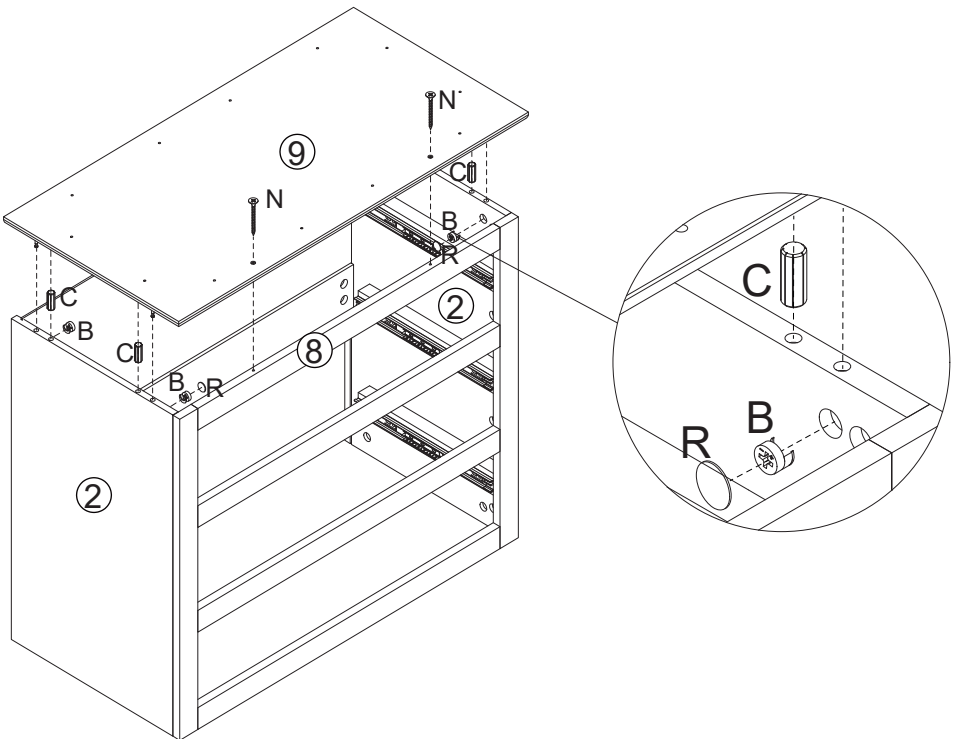

STEP 11

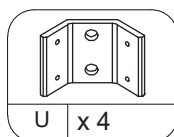
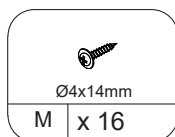
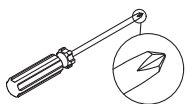

Secure iron plate U onto panels 10 and 11 using screw M

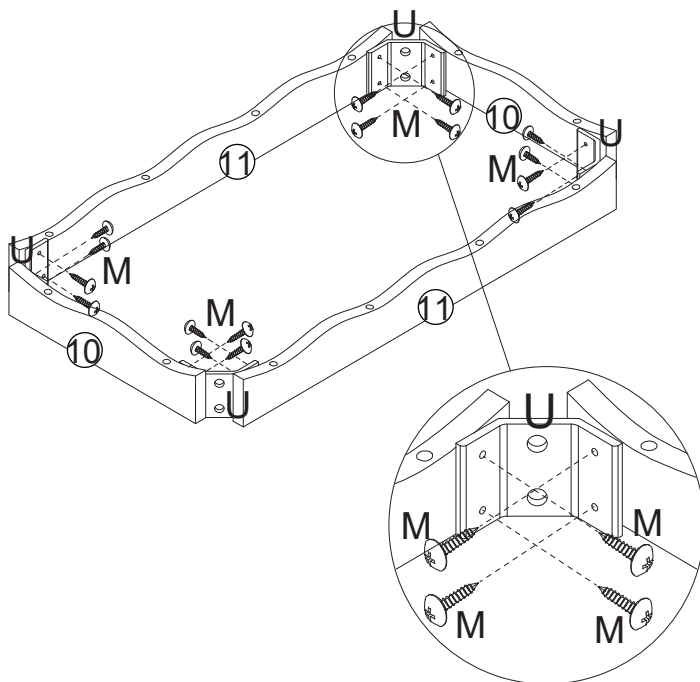

STEP 12

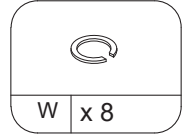
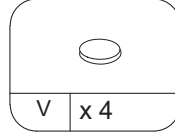
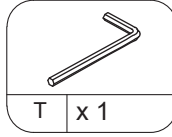
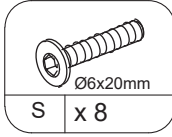
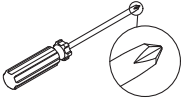

Connect Leg 12 to panels 10 and 11
Secure it with screws S and spring washers W, and tighten with wrench T
Finally, attach foot pad V

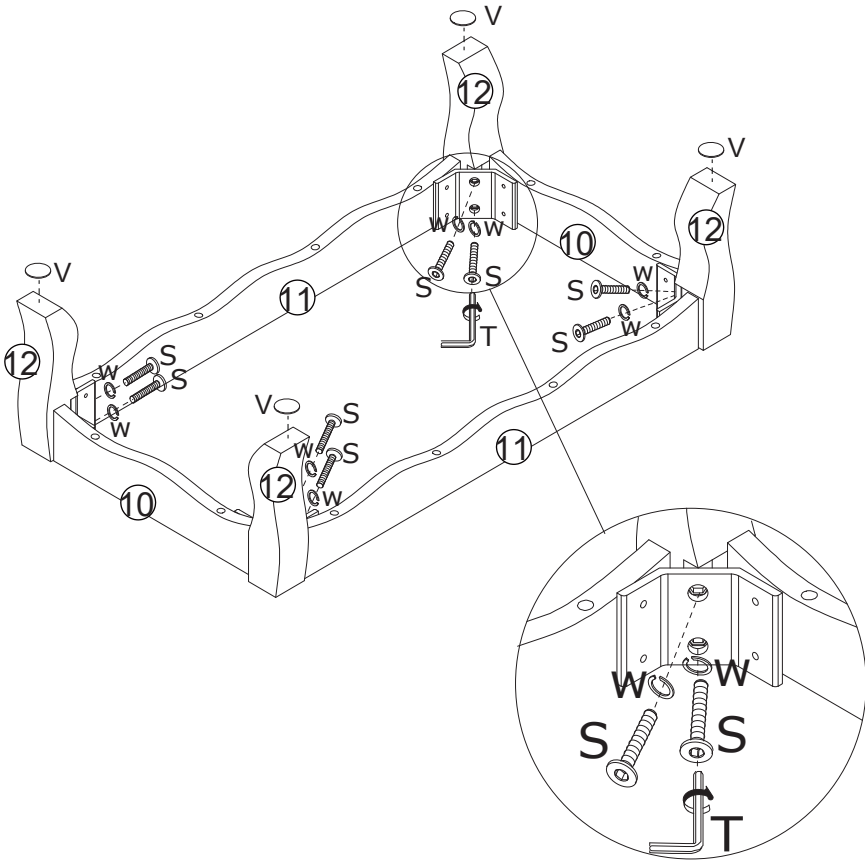

STEP 13

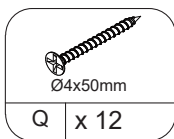
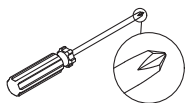

Secure the assembled components onto panel 9 using screw Q

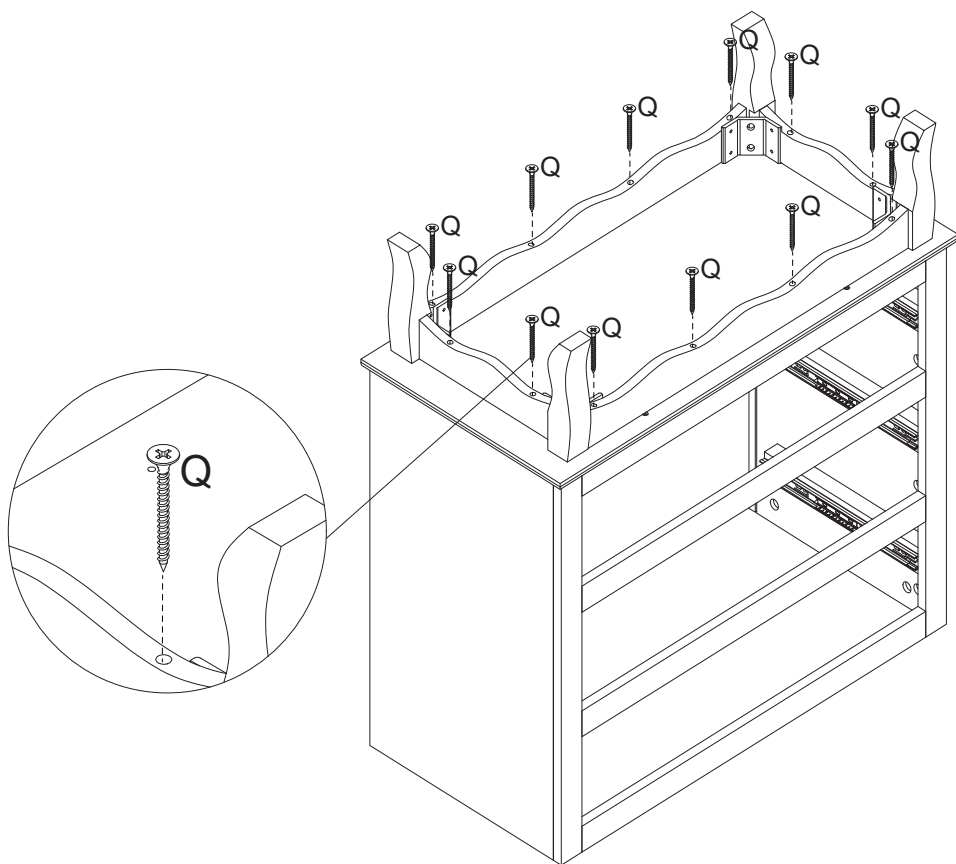

STEP 14

Slide back panel 5 into the assembled components

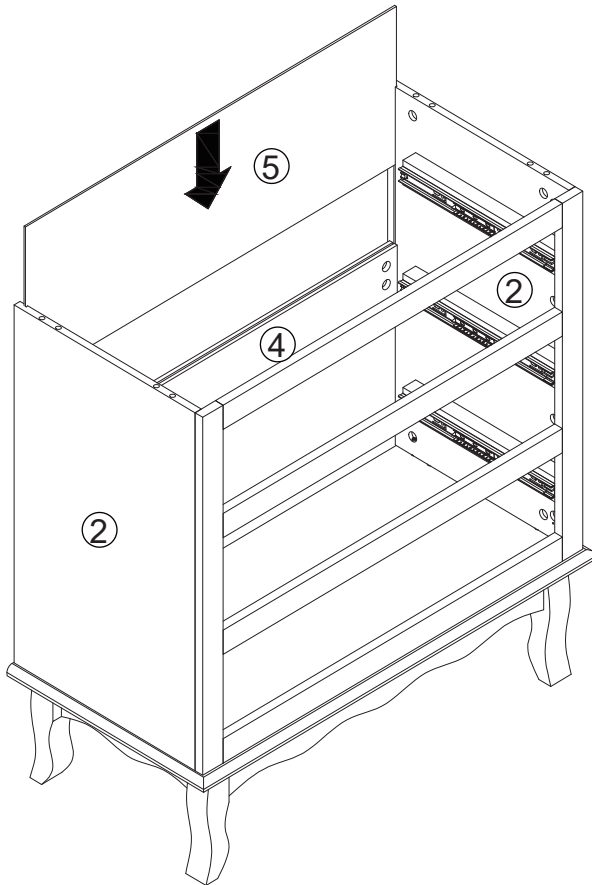

STEP 15

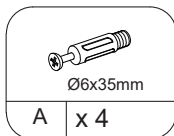
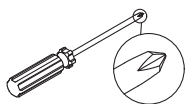

Secure screw A onto panel 1

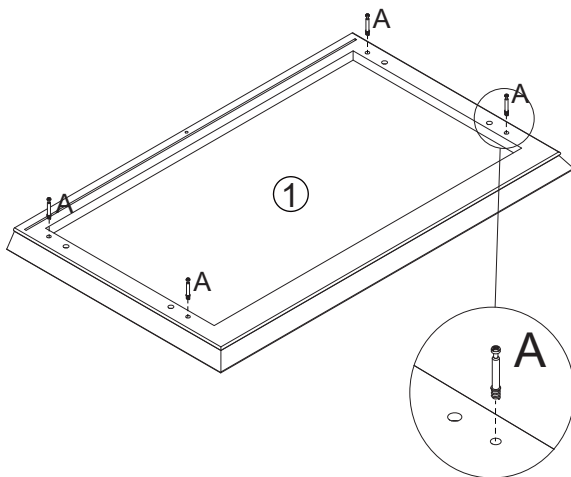

STEP 16

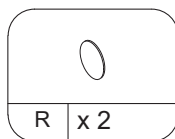
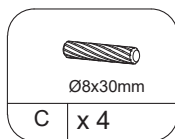
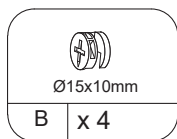
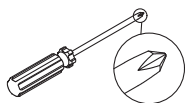

Connect panel 1 to panel 2 using wooden dowel C,
then tighten eccentric wheel B clockwise
Finally, affix hole sticker R

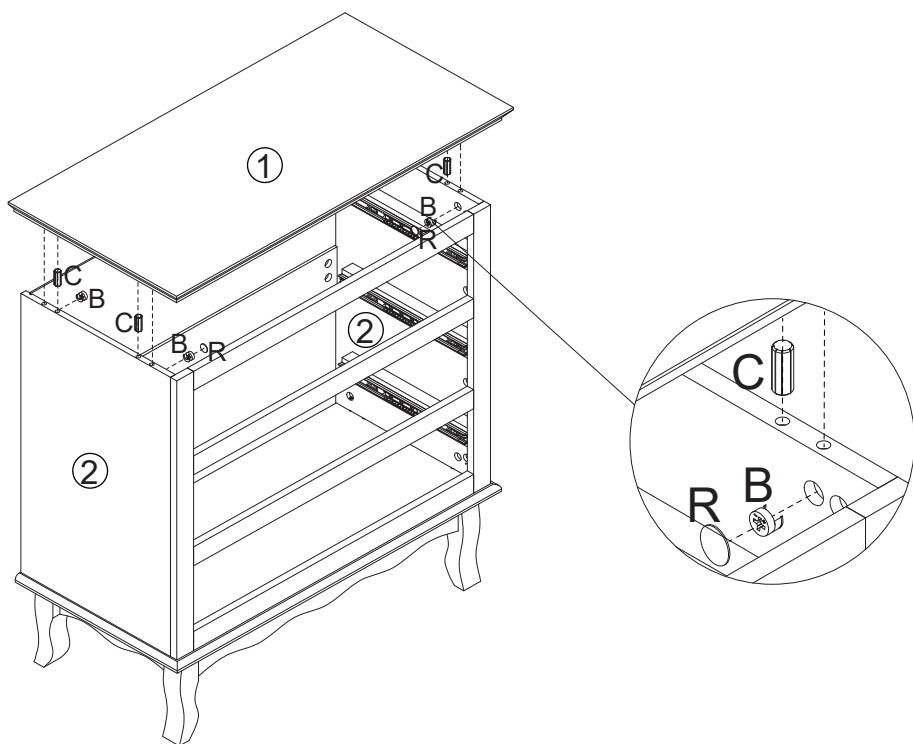

STEP 17

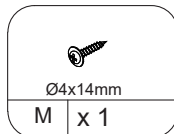
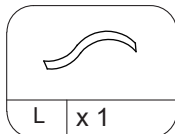
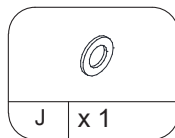
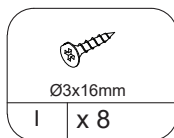
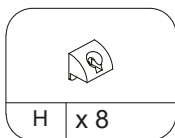
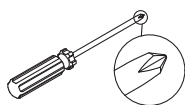

Secure back panel fastener H to the back panel using screw I, then install the anti-tip device on panels 1
Please install all the back panel fasteners for enhanced stability

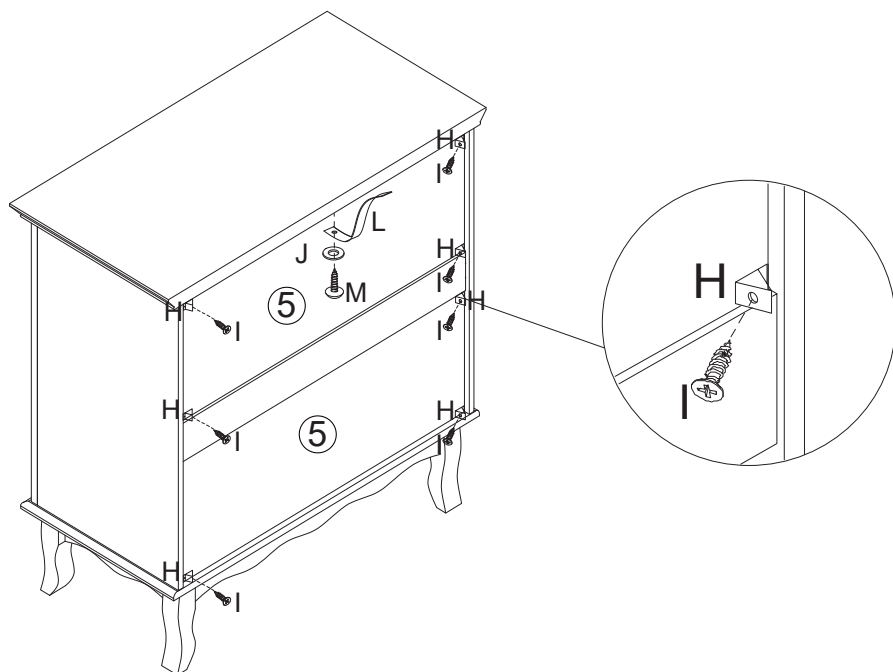

STEP 18

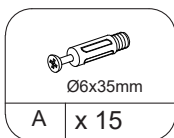
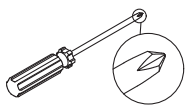

Secure screw A onto panel 13

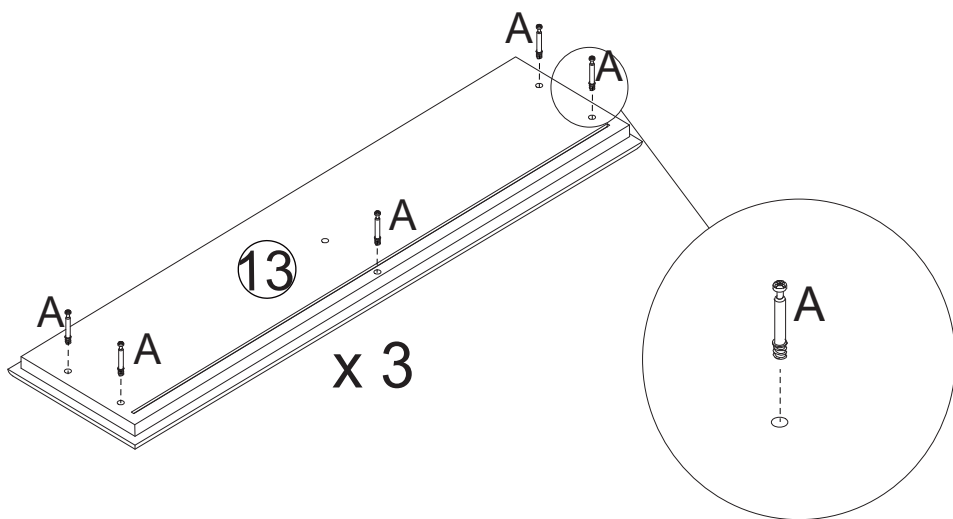

STEP 19

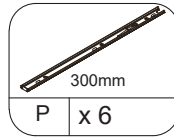
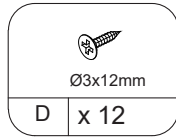
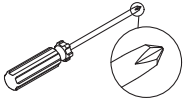

Secure drawer slider P onto panels 14 and 15 using screw D

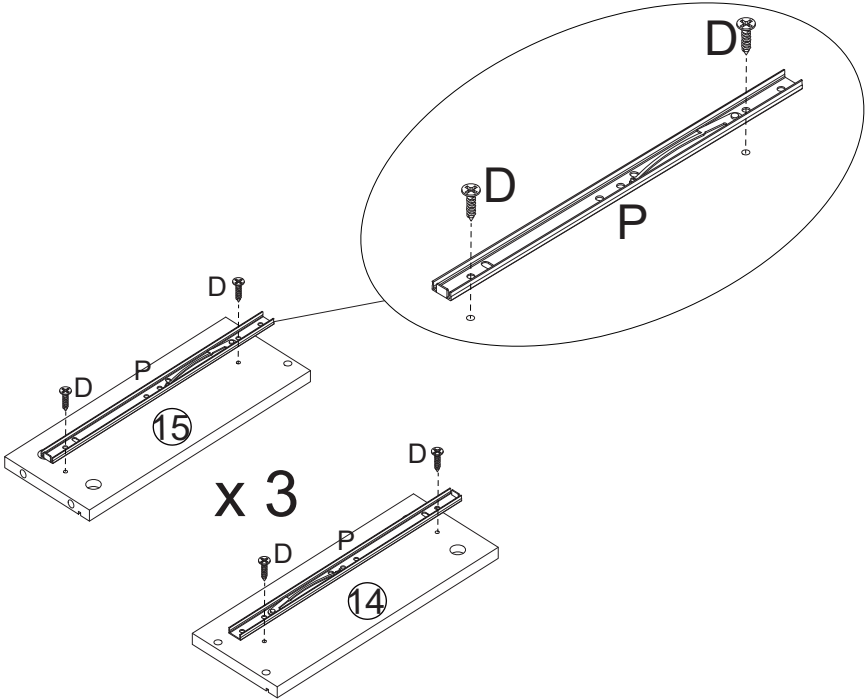

STEP 20

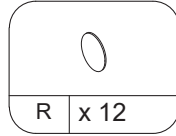
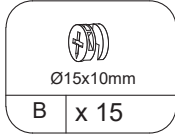
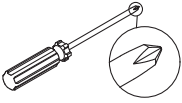

Connect panels 14, 15, and 16 to panel 13,
then tighten eccentric wheel B clockwise
Finally, affix hole sticker R

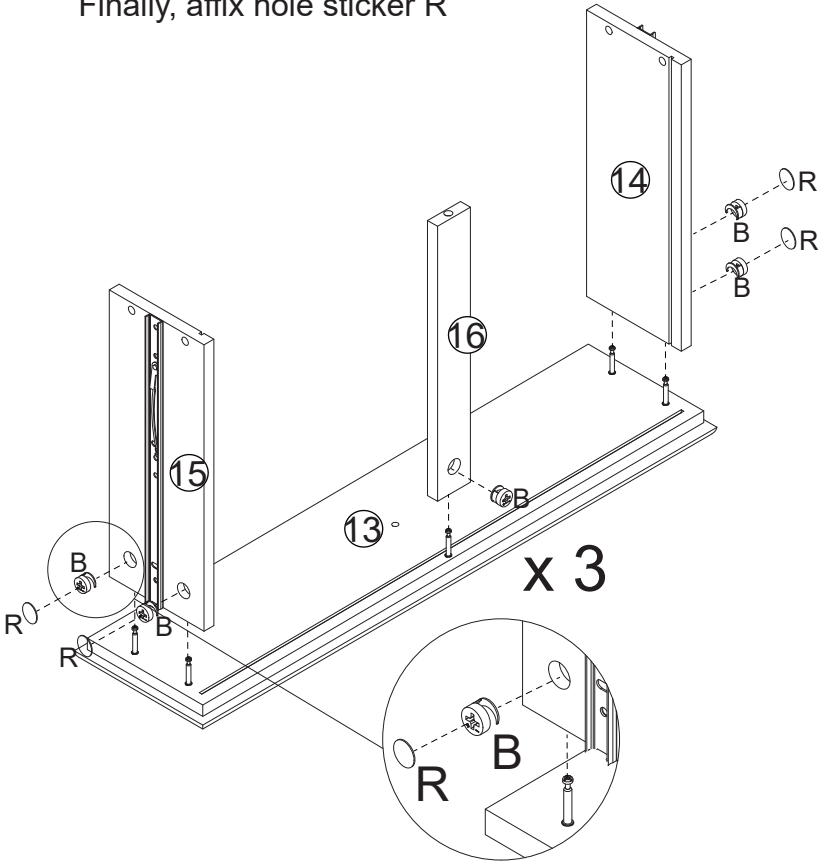

STEP 21

Slide the bottom panel 17 into the assembled components

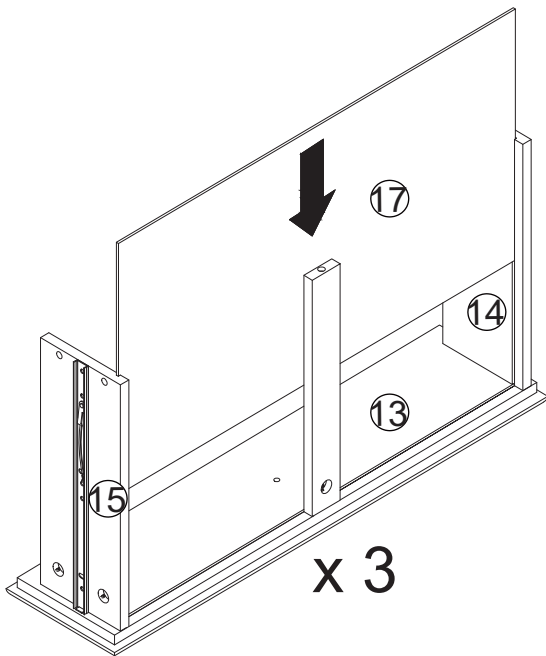

STEP 22

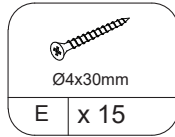
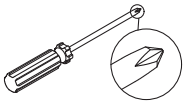

Connect panel 18 to the assembled components and secure it with screw E

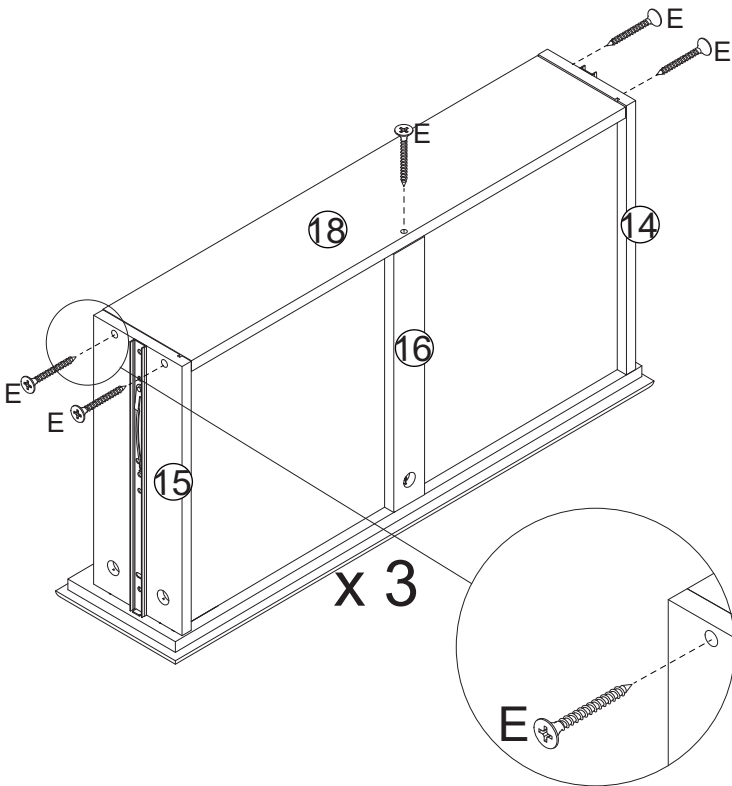

STEP 23

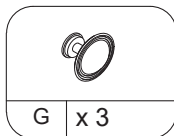
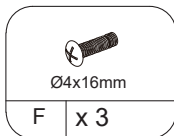
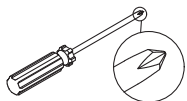

Secure handle G onto panel 13 using screw F

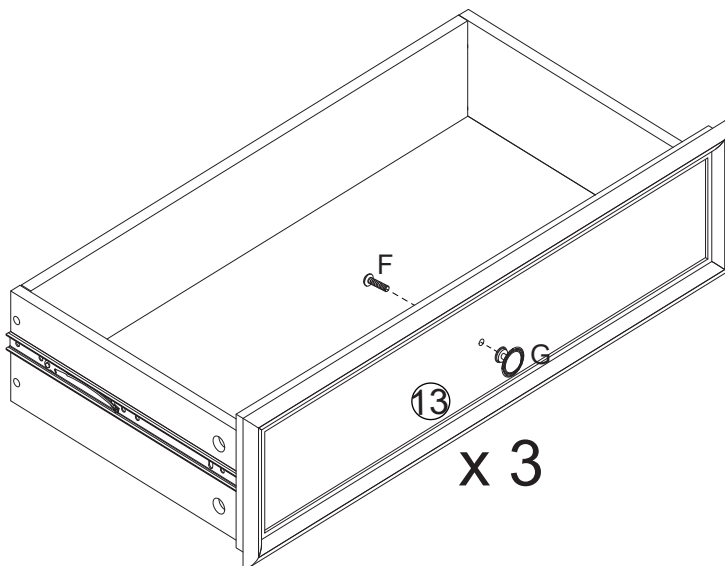

STEP 24

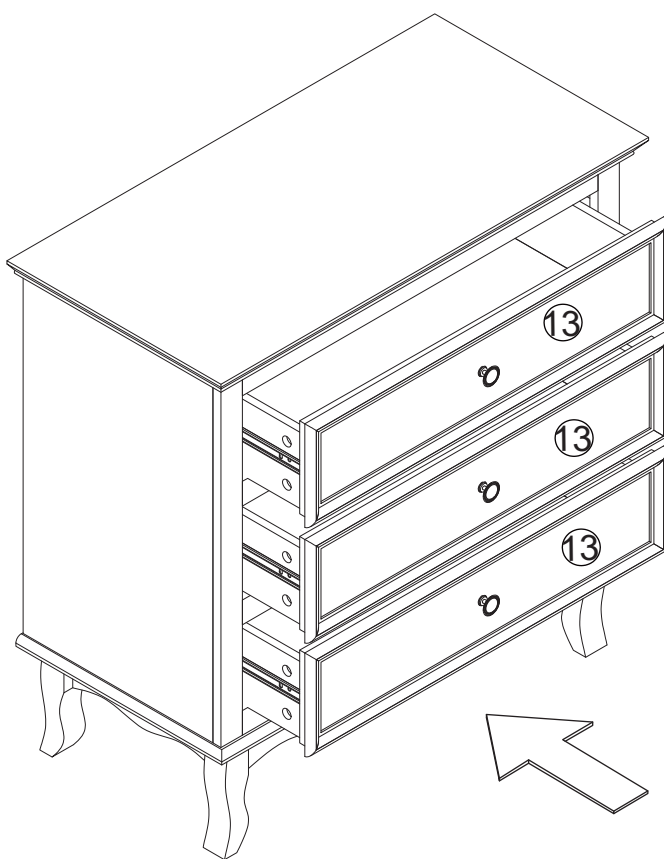

Place the drawers inside the cabinet

STEP 25

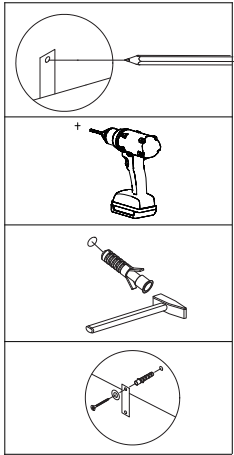
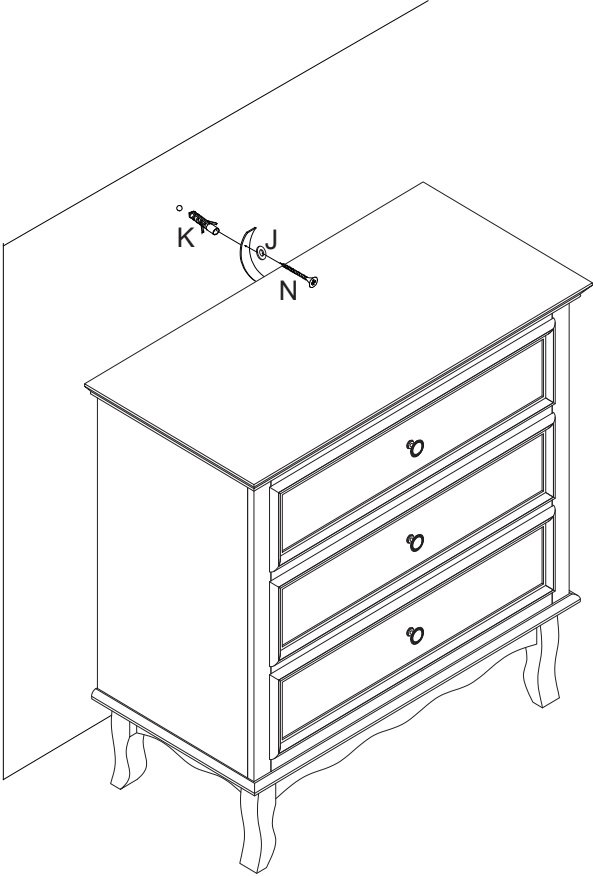
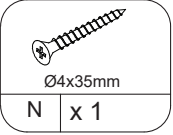
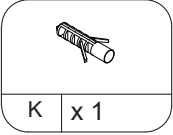
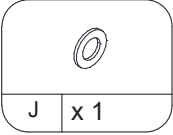
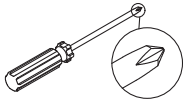

Use components K, J, and N to assemble anti-tip device L on the wall to prevent tipping

MAINTENANCE AND CARE



Following these few basic steps will help to ensure that you enjoy your furniture for a long time:

Do not expose your furniture to direct sunlight, dampness or any heat, like a hot cup of coffee or tea.
Always use a coaster.

Dust with a clean, damp, lint free cloth.

Use a damp cloth with water or mild detergent to clean all surfaces - do not use chemicals or paint thinner which will fade the surface.

Place a piece of felt or a pad under the legs of your furniture to avoid scratching the floor.

WARRANTY INFORMATION



Warranty Coverage: Our warranty provides protection against manufacturing defects in materials and workmanship for a specified period from the date of purchase, as outlined in the accompanying warranty documentation.

Exclusions: The warranty does not cover damages resulting from misuse, negligence, accidents, normal wear and tear, unauthorized repairs or modifications, improper assembly, or failure to adhere to the care and maintenance guidelines provided.