

ASSEMBLY INSTRUCTIONS

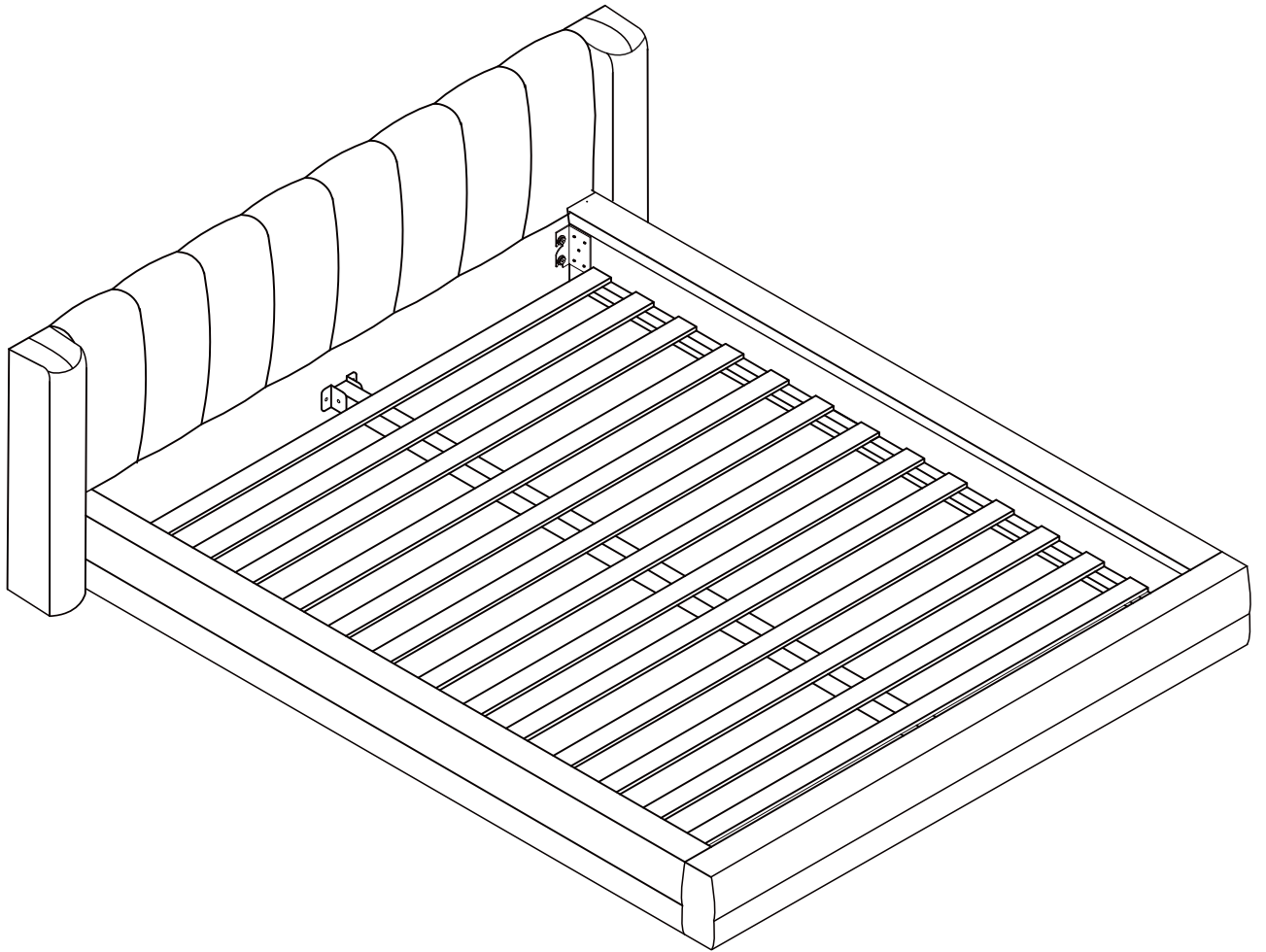

NOTE: The slats are stored at the bottom of Section A

STEP :Packing Details

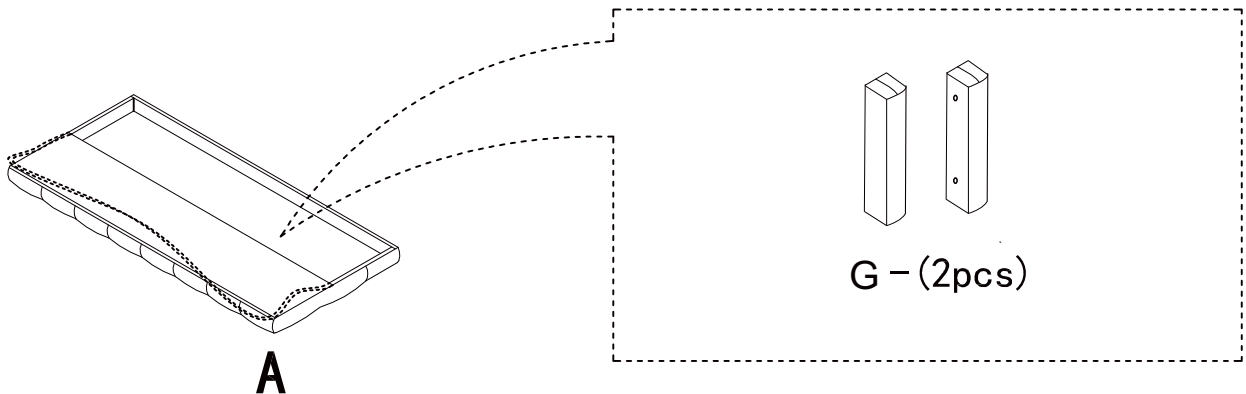





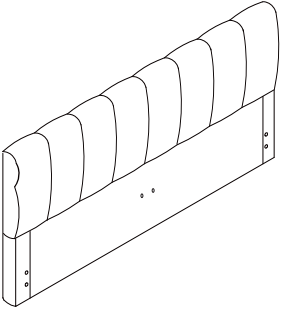
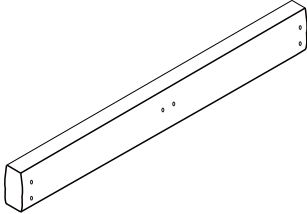
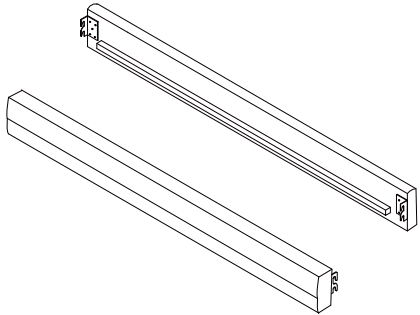
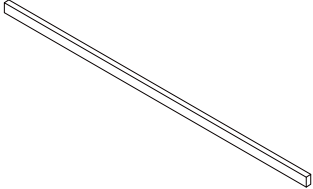
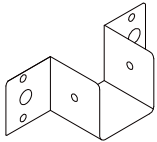
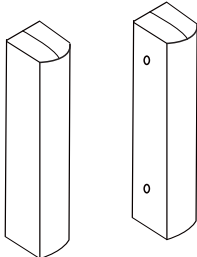
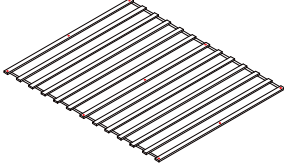

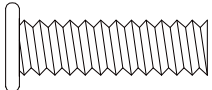
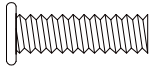

PARTS AND HARDWARE

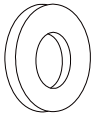
Parts List

 <p>A-HeadBoard (1pc)</p>	 <p>B-Foot Board (1pc)</p>	 <p>C-Side Rails (2pcs)</p>
 <p>D-Center Support Bar (1pc)</p>	 <p>E- (2pcs)</p>	 <p>G - (2pcs)</p>
 <p>F-Slats (13pcs)</p>		

HARDWARE LIST:

 <p>m8*30 Bolt 1 - (8pcs)</p>	 <p>m6*25 Bolt 2 - (4pcs)</p>	 <p>m8 Spring Washer 3 - (8pcs)</p>	 <p>m8*16 Flat Washer 4 - (8pcs)</p>
 <p>m6*16 Flat Washer 5 - (4pcs)</p>	 <p>m8 Allen Key 6 - (1pcs)</p>	 <p>m6 Allen Key 7 - (1pcs)</p>	 <p>M4*25 Screw 8 - (9pcs)</p>
 <p>Screw 9 - (4pcs)</p>			

ASSEMBLY INSTRUCTIONS

STEP 1:

9 - Screw
(4pcs)

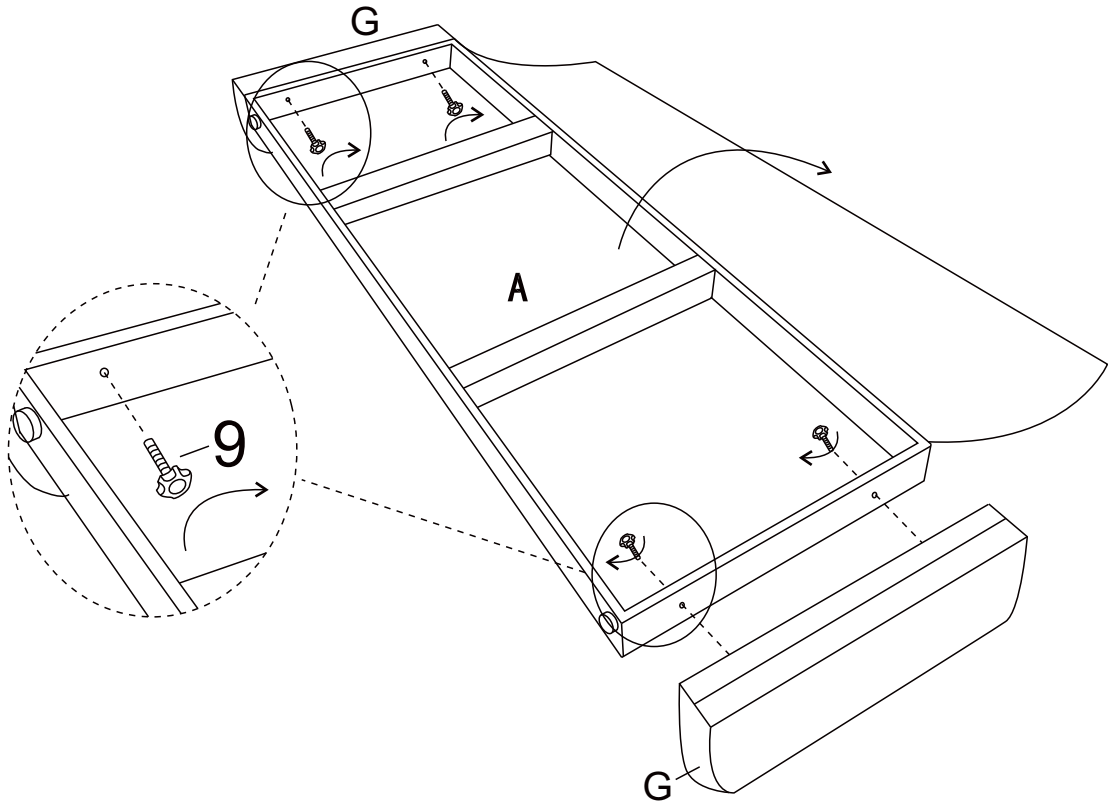

STEP 2:



m8*30

1 - Bolt (8pcs)



3 - Spring Washer
(8 pcs)



m8*16

4 - Flat Washer
(8pcs)

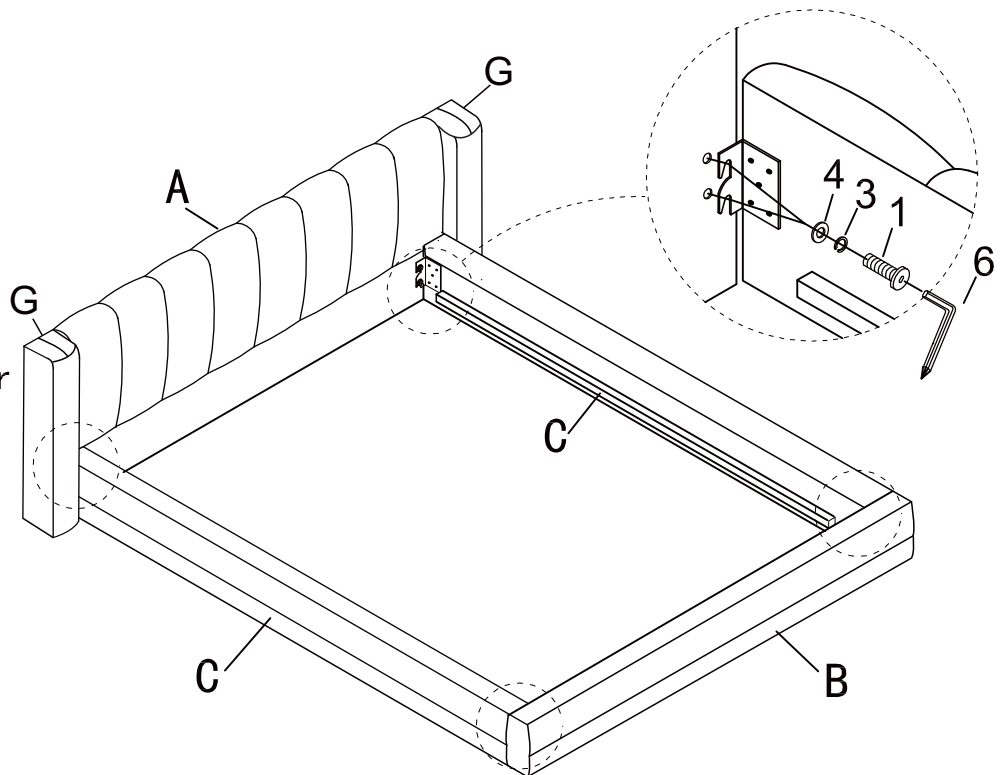

ASSEMBLY INSTRUCTIONS

STEP 3:



m6*25

2 -Bolt (4pcs)



m6*16

5 -Flat Washer (4pcs)



E- (2pcs)

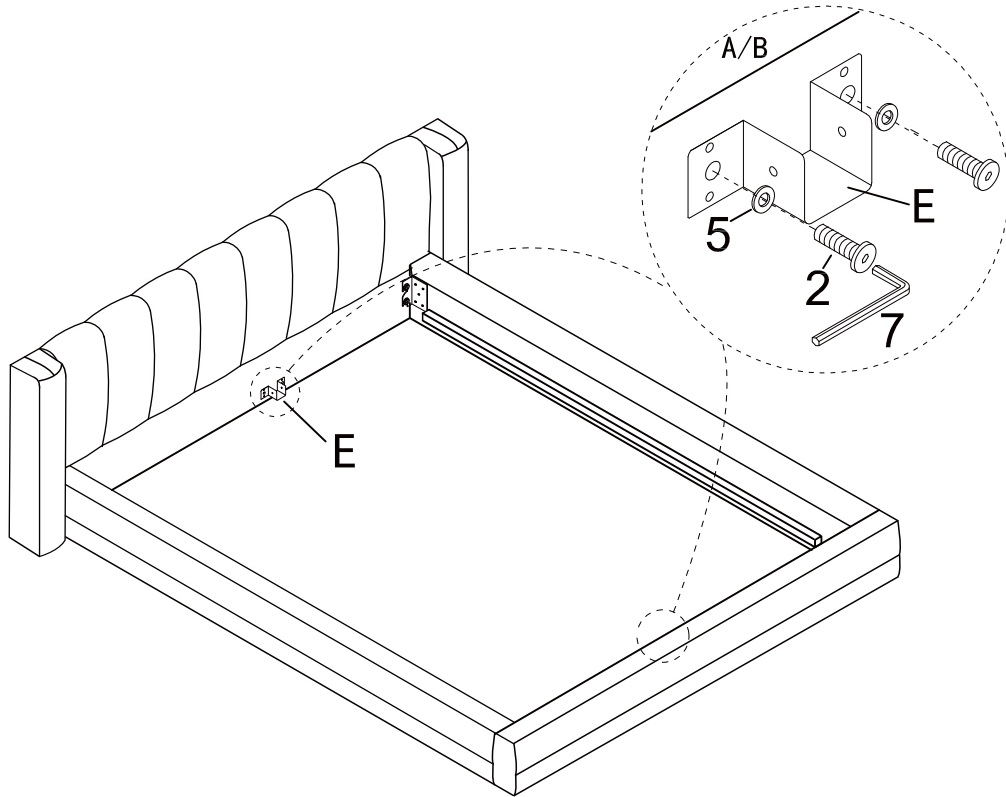

STEP 4:

F-Slats (13pcs)

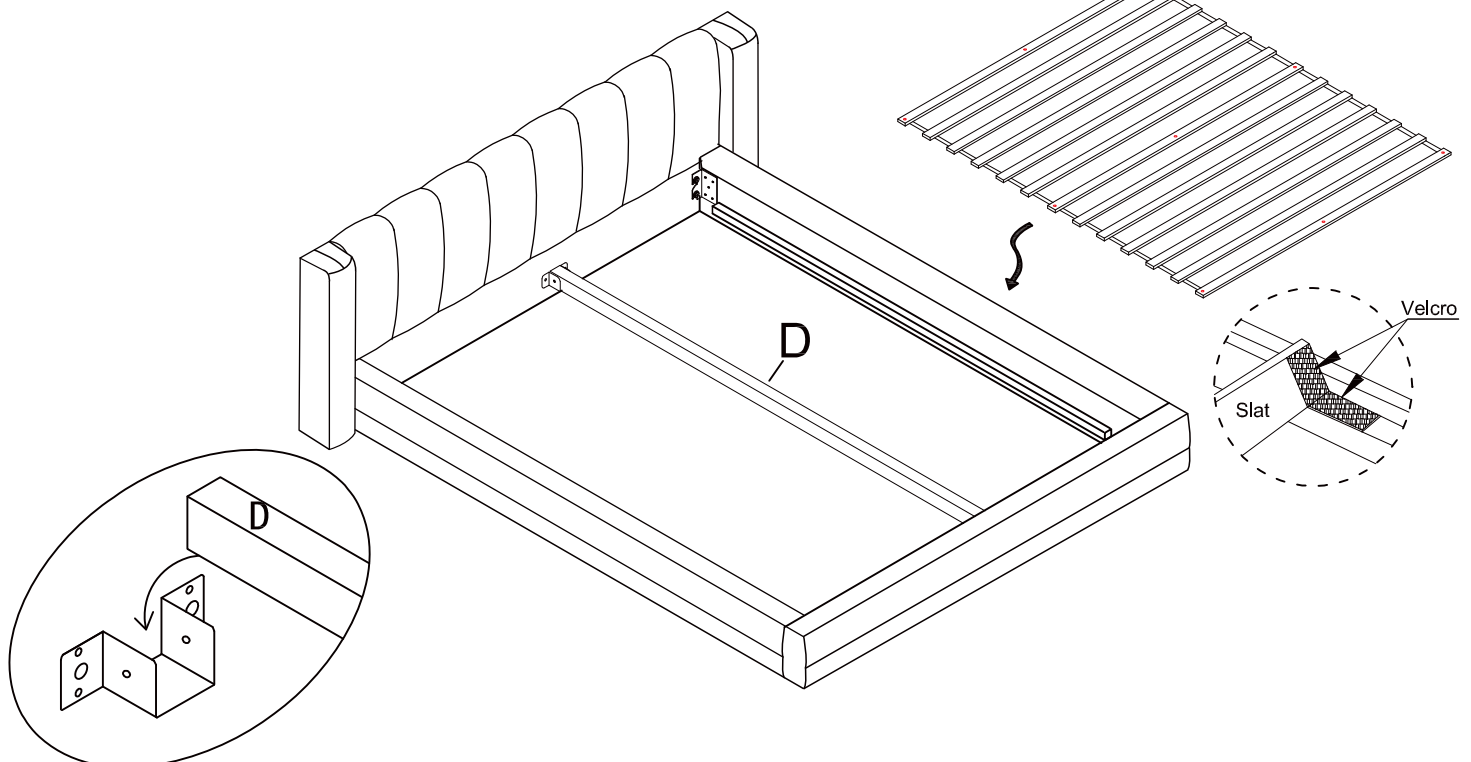

ASSEMBLY INSTRUCTIONS

STEP 5:

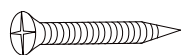

M4*25

8 - Screw (9pcs)

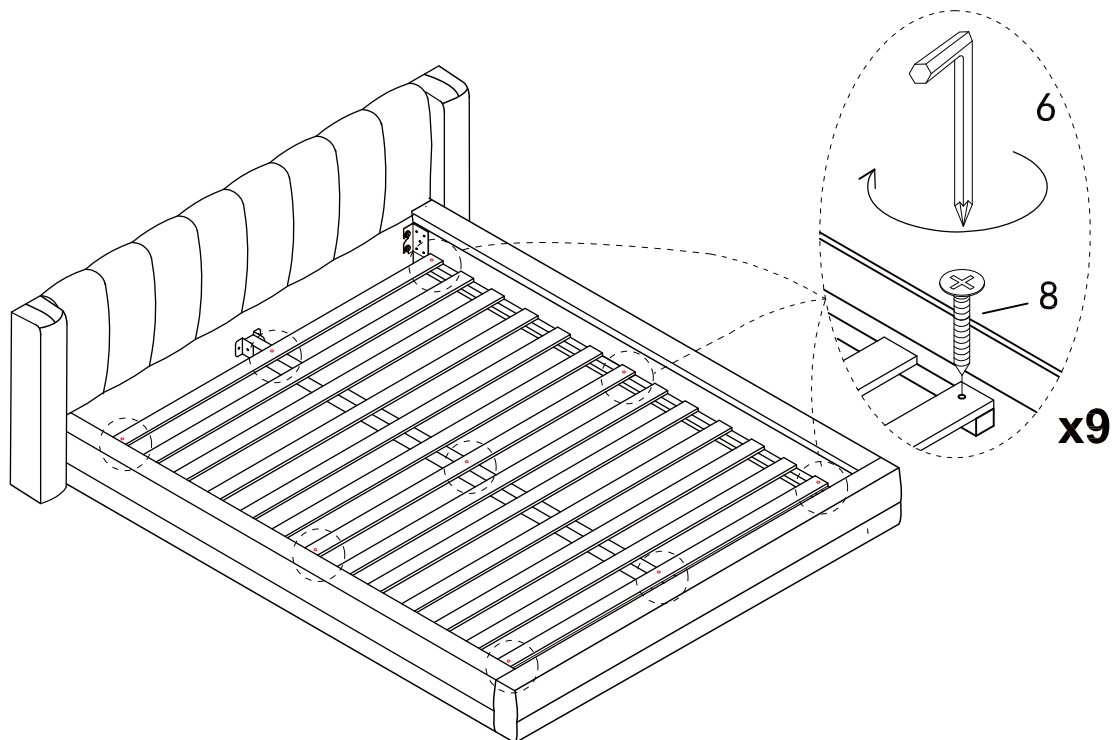

STEP 6:

