









## CARE AND MAINTENANCE

Dust with a dry cloth. Do not use abrasive cleaner. Use glass cleaner to clean surface of table top.

## NOTICE

- \* Please make sure that you have all parts indicated before you begin assembly of this item
- \* This item should be assembled on a soft surface to prevent scratching the finish during assembly
- \* This item may require periodic tightening

## Part List and Hardware List

PIECE	DESCRIPTION	PICTURE	QUANTITY
A	Table Top		1X
B	Leg-1		1X
C	Leg-2		1X
D	Leg-3		1X
H1	Screw-L (M6*55mm)		2X
H2	Screw-S (M6*22mm)		4X
H3	Spring Washer		6X
H4	Flat Washer		6X
H5	Allen Key		1X

Product Dimensions: 31.5"D x 30"H



**Weight Capacity : 25 lbs**  
**Warning : Do not stand on table**  
**Warning : Do not over torque bolts**



**PREPARATION**

Before beginning assembly of product, make sure all parts are present. Compare parts with package contents list and hardware contents list. If any part is missing or damaged, do not attempt to assemble the product.

Estimated Assembly Time: 8 minutes.

Tools Required for Assembly (included): Allen Key

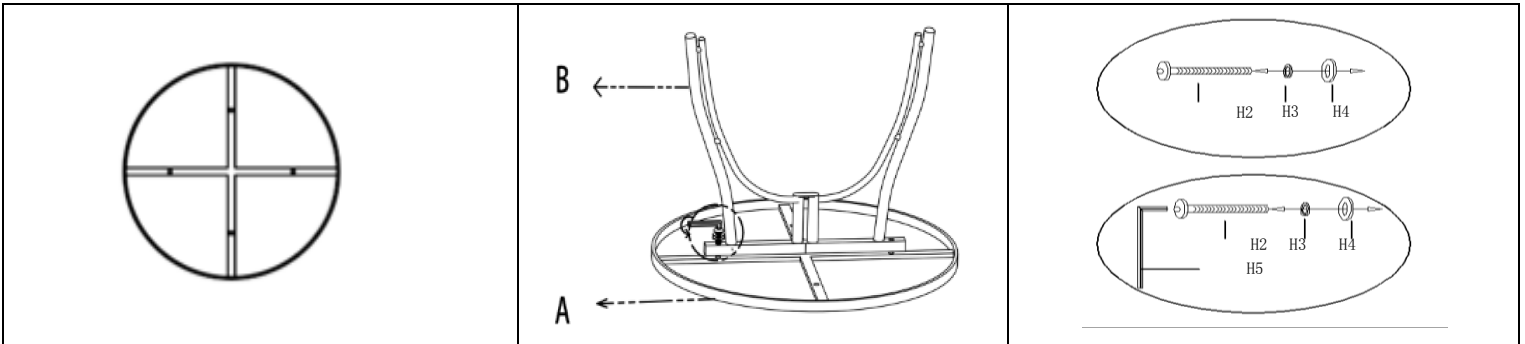

**STEP1** PLACE TABLETOP (A) FACE DOWN ON A SMOOTH SURFACE

**STEP2** INVERT LEG (B) AND ALIGN HOLE TO THREAD OPENING OF TABLETOP (A)

**STEP3** PUT THE WASHERS ON THE BOLT IN THE ORDER SHOWN IN THE PICTURE

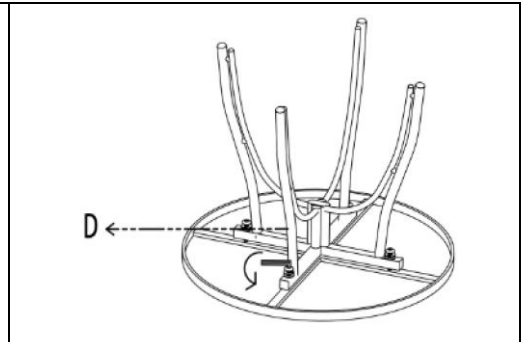
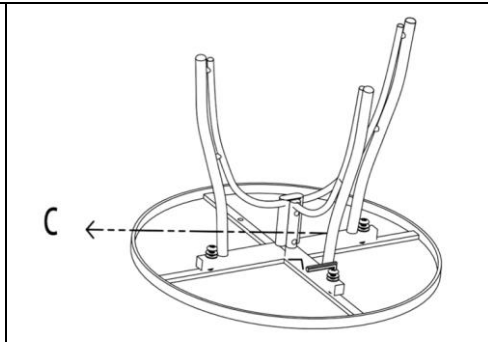
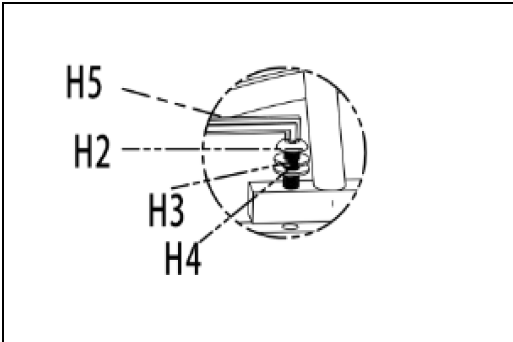

**STEP4** USE SCREW (H2) AND SECURE BOLTS TIGHTLY

**STEP5** REPEAT STEPS 3-4 FOR LEG (C) AS INDICATED IN PICTURE ABOVE

**STEP6** REPEAT STEPS 3-4 FOR LEG (D) AS INDICATED IN PICTURE ABOVE.

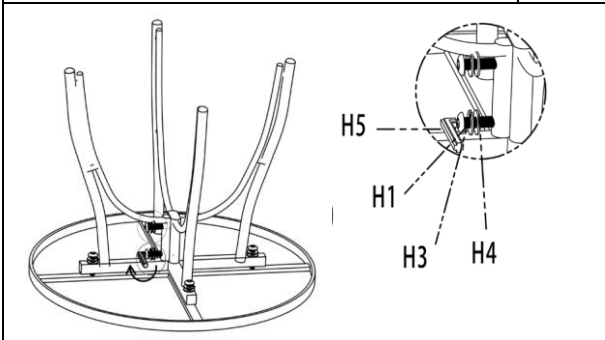

**STEP7** USE SCREW (H1) AND SECURE BOLTS TIGHTLY (THE TWO THREAD OPENINGS ARE LOCATED PERPENDICULAR TO TABLE TOP). SECURE ALL SCREWS TIGHTLY. THIS ITEM MAY REQUIRE PERIODIC TIGHTENING