

# FULL/QUEEN BED ASSEMBLY INSTRUCTION

Thank you for purchasing this quality product. Be sure to check all packing material carefully for small parts which may have come loose inside the carton during shipment. Separate, identify and count all parts and hardware. Compare with the parts list to be sure all parts are present.

**IMPORTANT : PLEASE READ INSTRUCTION BEFORE STARTING THE ASSEMBLY.**

**"DO NOT TIGHTEN SCREWS UNTIL COMPLETELY ASSEMBLED"**

**"DO NOT OVERTIGHT ANY HARDWARE"**

**WARNING : SMALL PARTS AND HARDWARE NOT FOR CHILDREN UNDER 3 YEARS. ADULT ASSEMBLY REQUIRED.**

## TABLE OF CONTENTS

HARDWARES LIST	PAGE 2
PARTS LIST	PAGE 3
PARTS' LOCATION	PAGE 4
ASSEMBLY STEPS	PAGE 5 - 8
ASSEMBLY COMPLETED	PAGE 9

## ASSEMBLY TOOLS REQUIRED

### 1. Screwdriver (not provide)



### 2. Hammer (not provide)











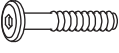



Skip the power drill this time.









# FULL/QUEEN BED ASSEMBLY INSTRUCTION

## HARDWARES LIST

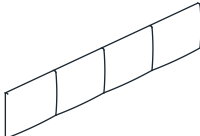
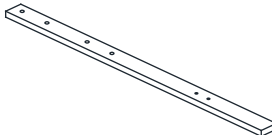
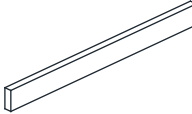
ITEM	DESCRIPTION	DRAWING	QTY
A	JCBB SCREW M8 x 20MM		8 PCS
B	JCBB SCREW M8 x 35MM		10 PCS
C	JCBC SCREW M6 x 25MM		8 PCS
D	JCBC SCREW M6 x 70MM		2 PCS
E	WOOD DOWEL M8 x 30MM		2 PCS
F	SPRING WASHER M6 x 12MM		8 PCS
G	FLAT WASHER M6 x 19MM		8 PCS
H	SPRING WASHER M8 x 13MM		10 PCS
I	FLAT WASHER M8 x 22MM		10 PCS
J	CSK C/B SCREW (M4 x 32MM)		8 PCS
K	M4 ALLEN KEY (100MM)		1 PC
L	M5 ALLEN KEY (65MM)		1 PC
M	SUPPORT LEG ADJUSTABLE FEET		4 PCS

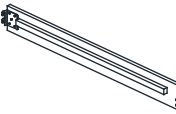
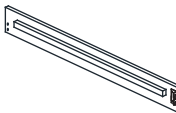
# FULL/QUEEN BED ASSEMBLY INSTRUCTION

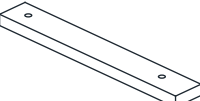
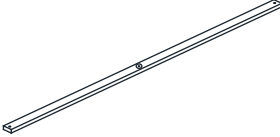
## PARTS LIST

ITEM	DESCRIPTION	DRAWING	QTY
1	HEADBOARD		2 PCS
2	HEADBOARD LEG		2 PCS
3	FOOTBOARD		1 PC
4	FOOTBOARD LEG		2 PCS
5	SIDE RAIL (L)		2 PCS
6	SIDE RAIL (R)		2 PCS
7	SIDE RAIL SUPPORT LEG		2 PCS
8	HEADBOARD SUPPORT (SHORT)		1 PC
9	SLAT		4 PCS
10	SUPPORT LEG WITH HANGER BOLT		4 PCS

MORE PARTS DETAIL IN NEXT PAGE...

# FULL/QUEEN BED ASSEMBLY INSTRUCTION

## PARTS ' LOCATION

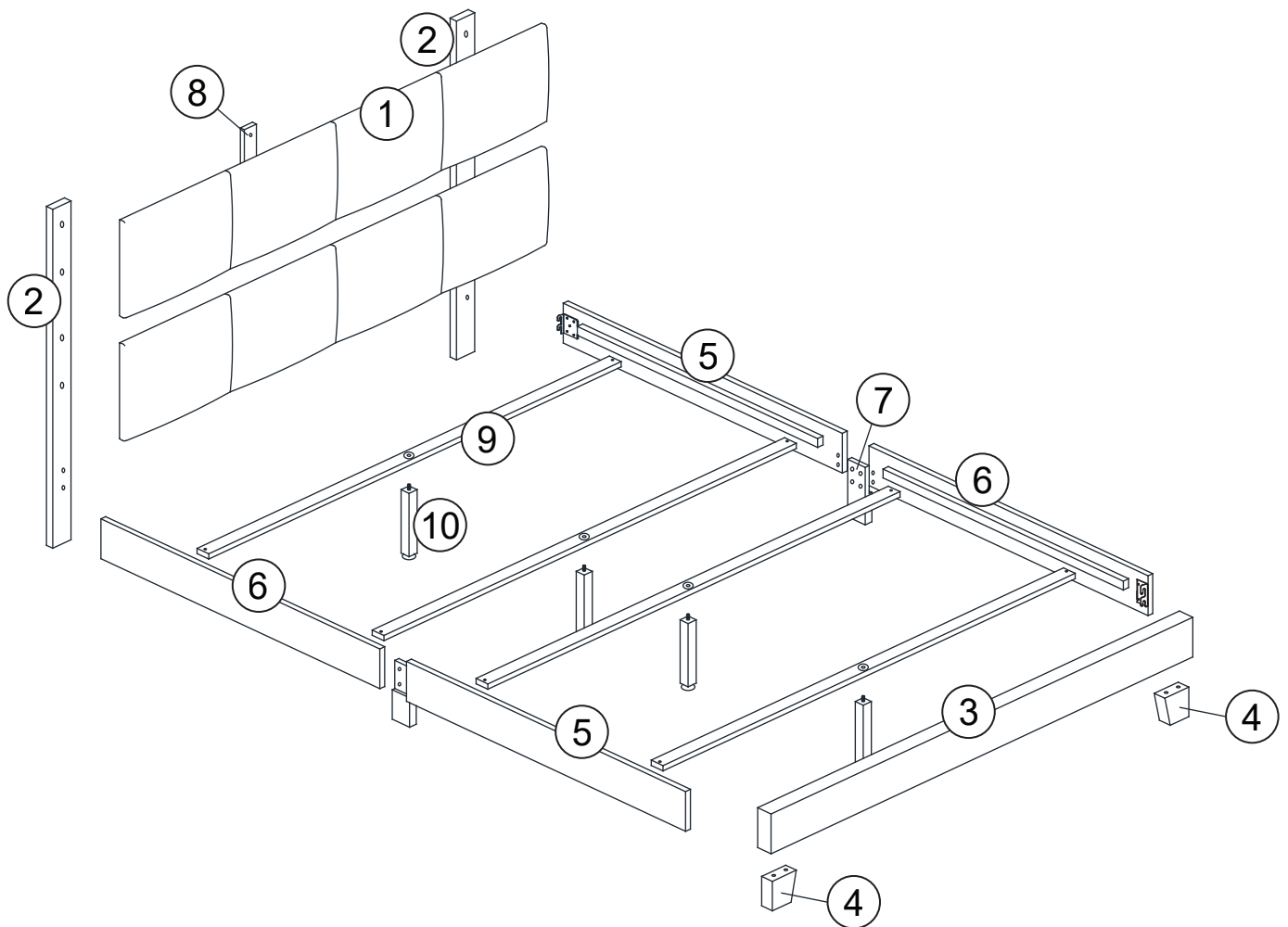

# FULL/QUEEN BED ASSEMBLY INSTRUCTION

## STEP 1

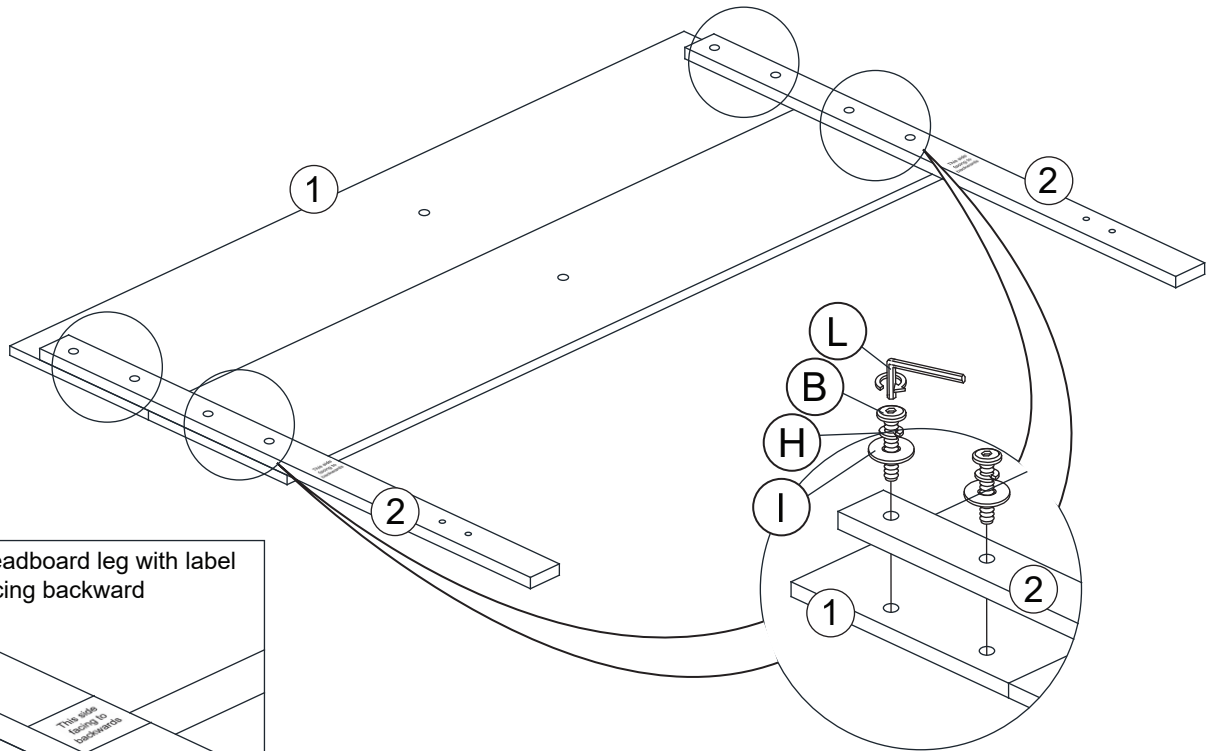

REMARK : Headboard leg with label facing backward

## STEP 2

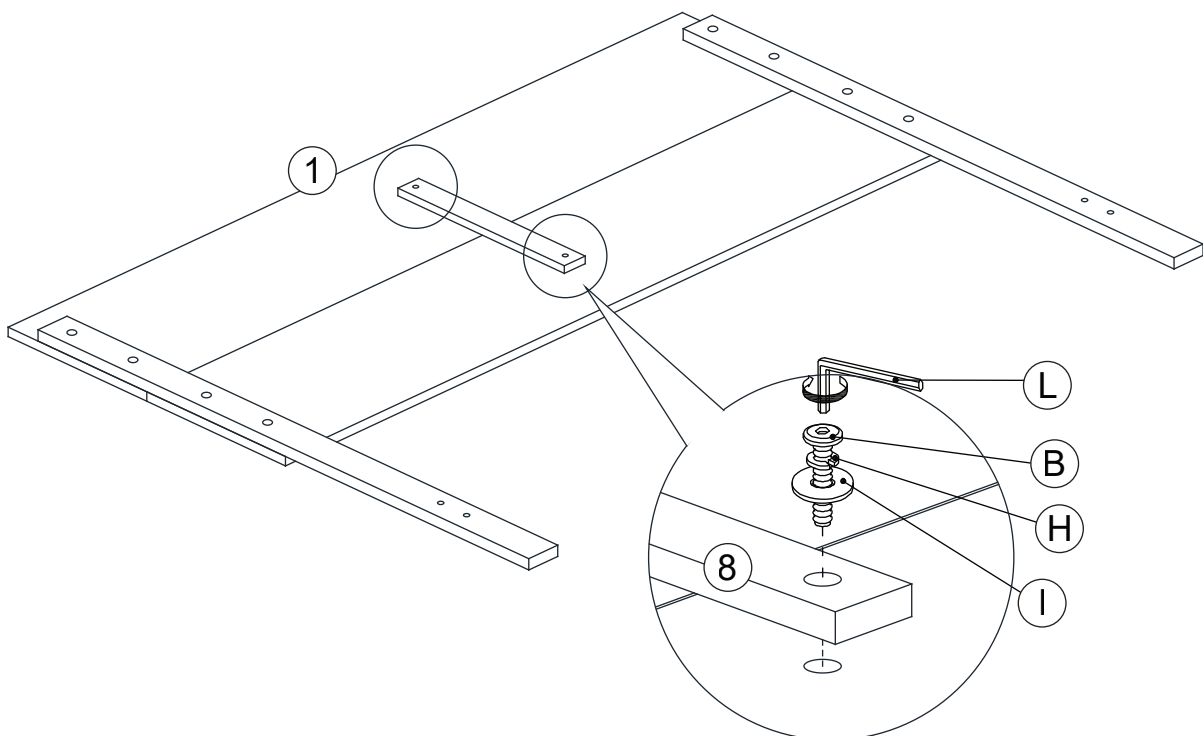

# FULL/QUEEN BED ASSEMBLY INSTRUCTION

## STEP 3

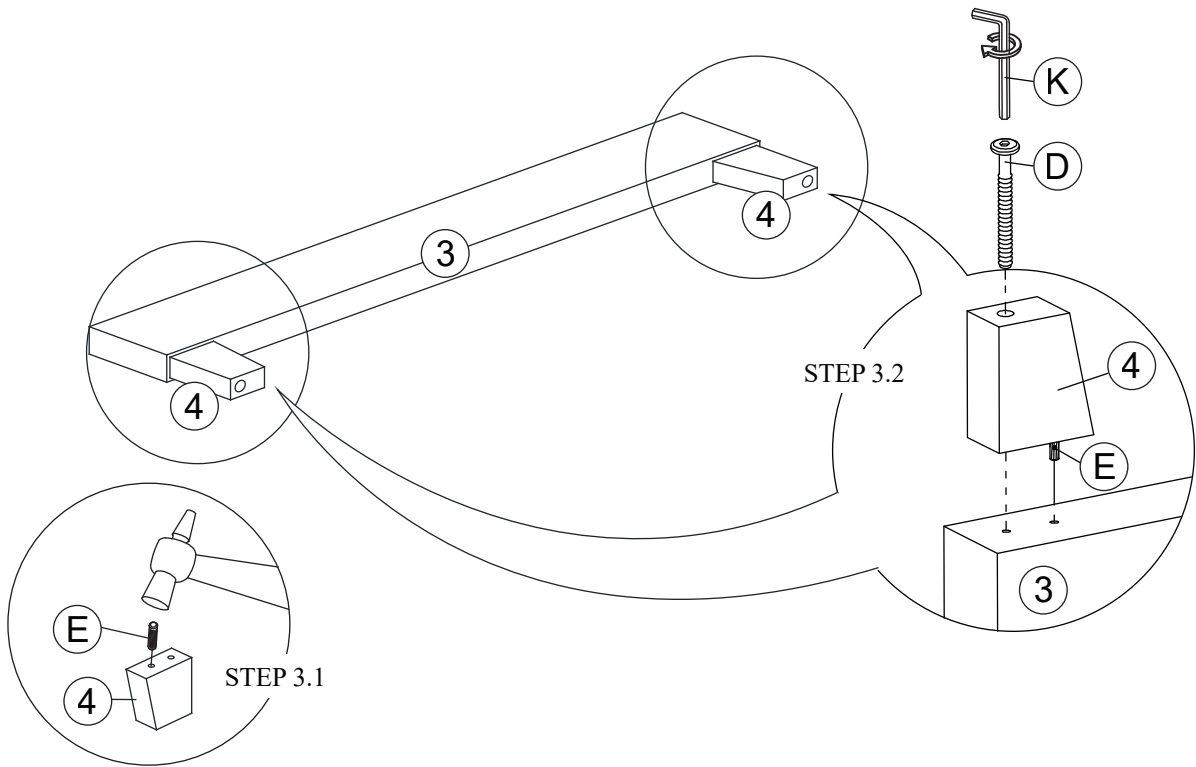

## STEP 4

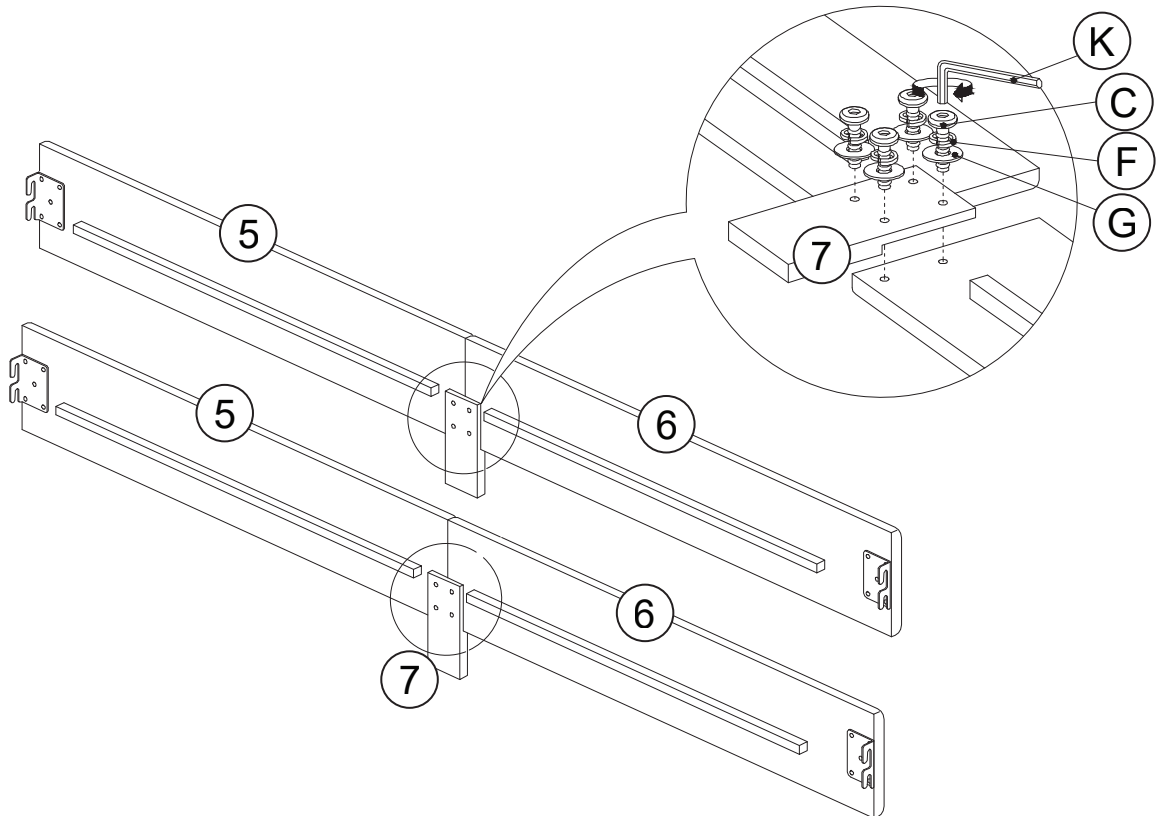

# FULL/QUEEN BED ASSEMBLY INSTRUCTION

## STEP 5

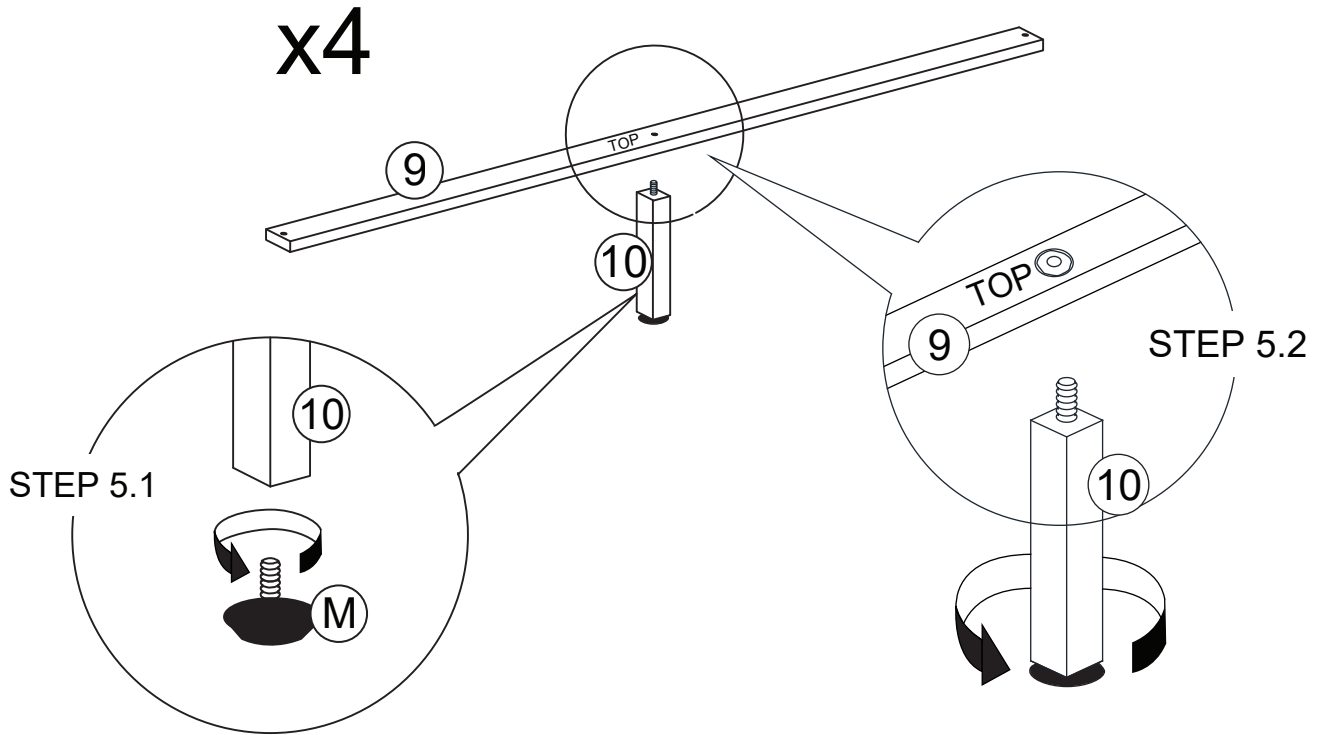

## STEP 6

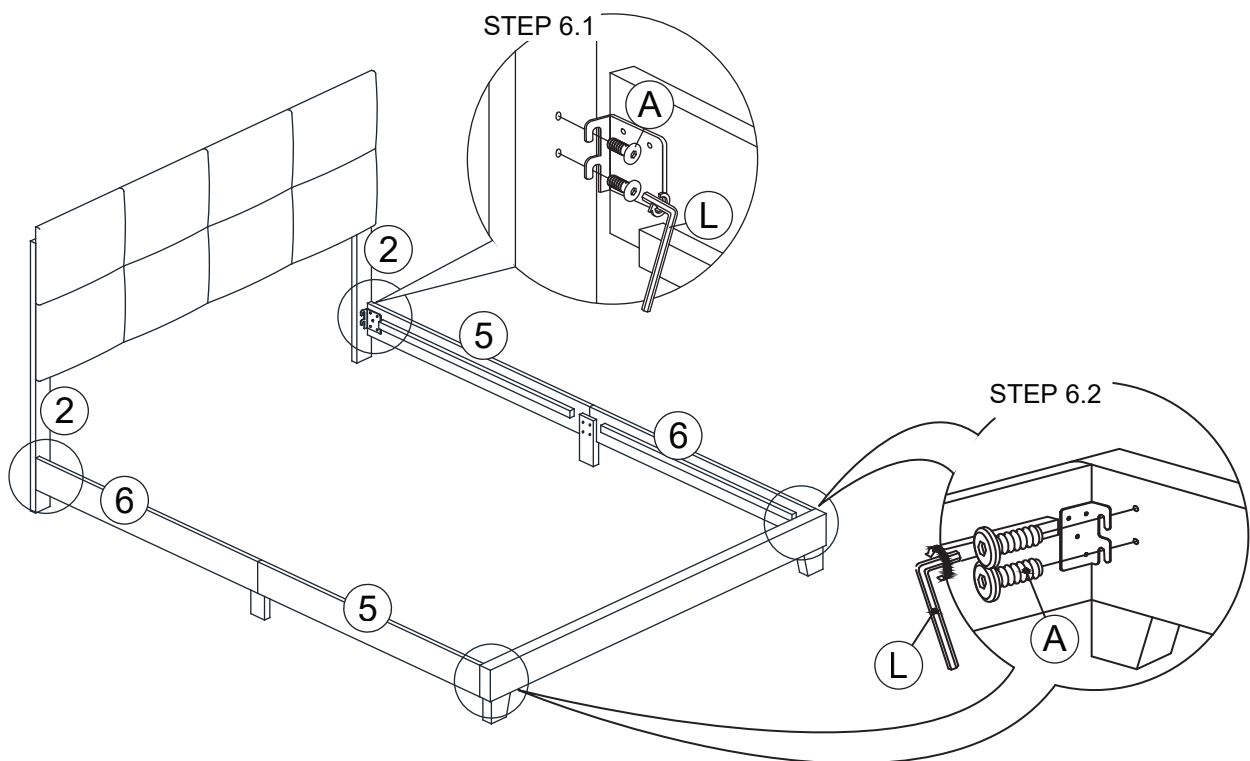

# FULL/QUEEN BED ASSEMBLY INSTRUCTION

## STEP 7

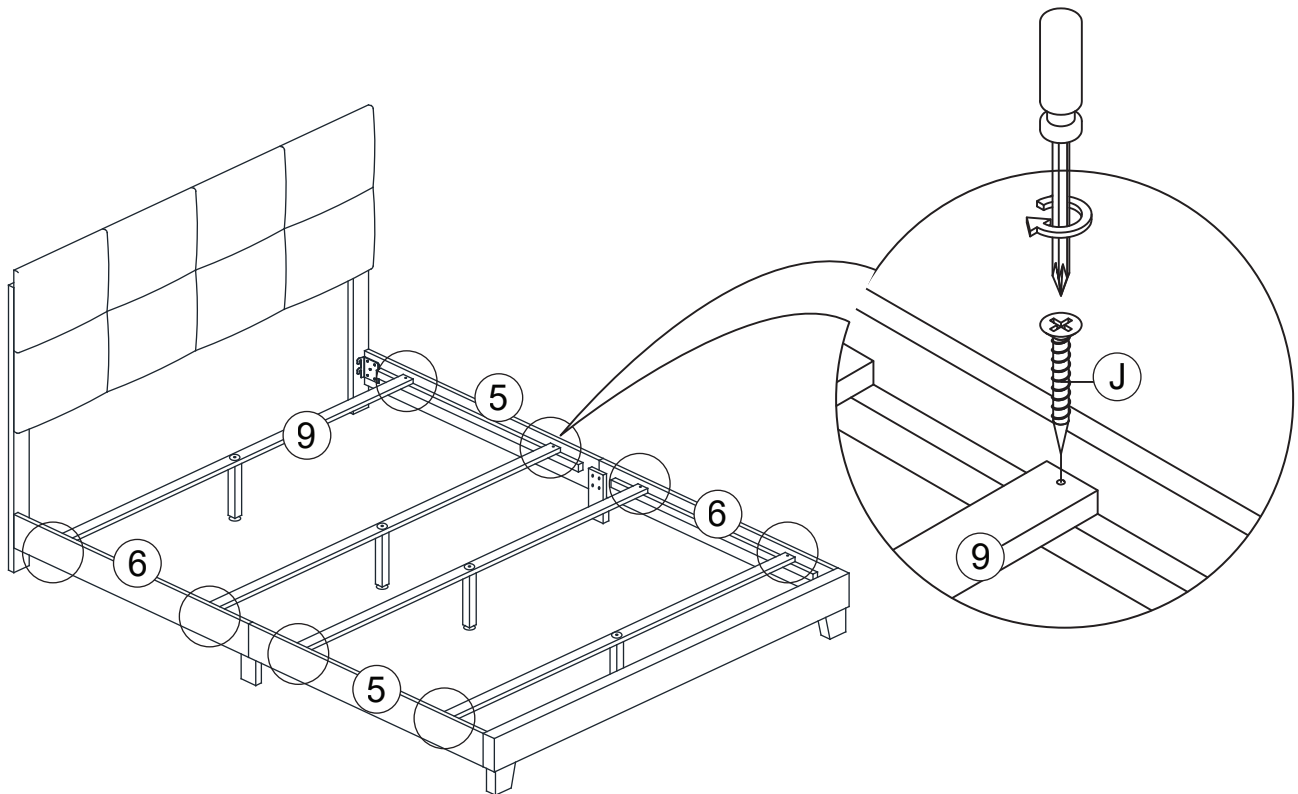

## STEP 8

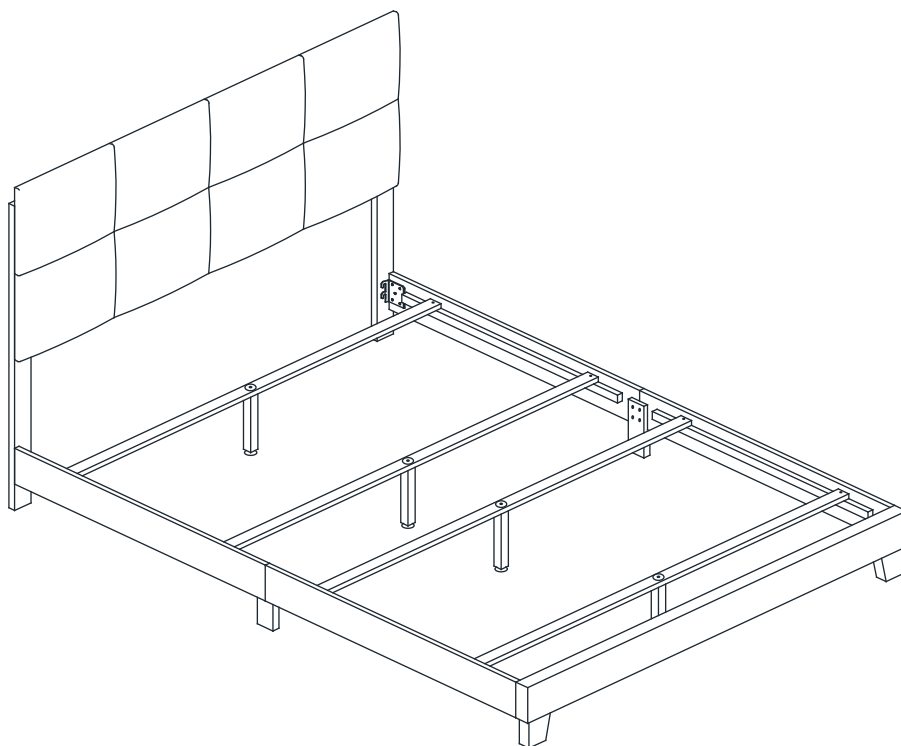

# FULL/QUEEN BED ASSEMBLY INSTRUCTION

## STEP 9

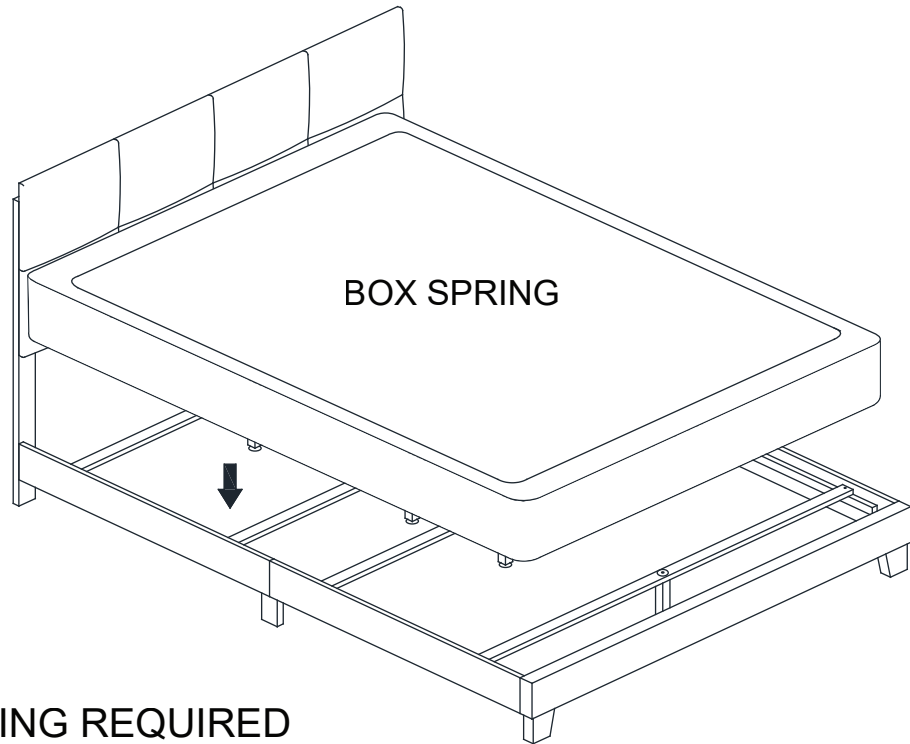

**BOX SPRING REQUIRED  
(NOT INCLUDED)**

## STEP 10

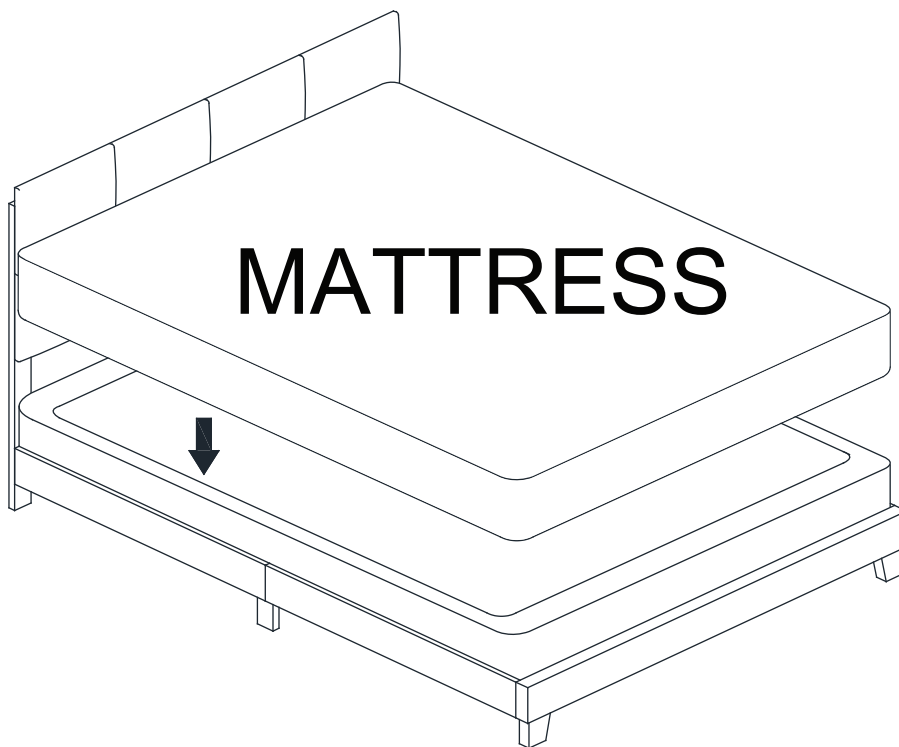

**MATTRESS NOT INCLUDED**

**ASSEMBLY COMPLETED**