

# ASSEMBLY INSTRUCTION

SKU CODE: (BW00407)

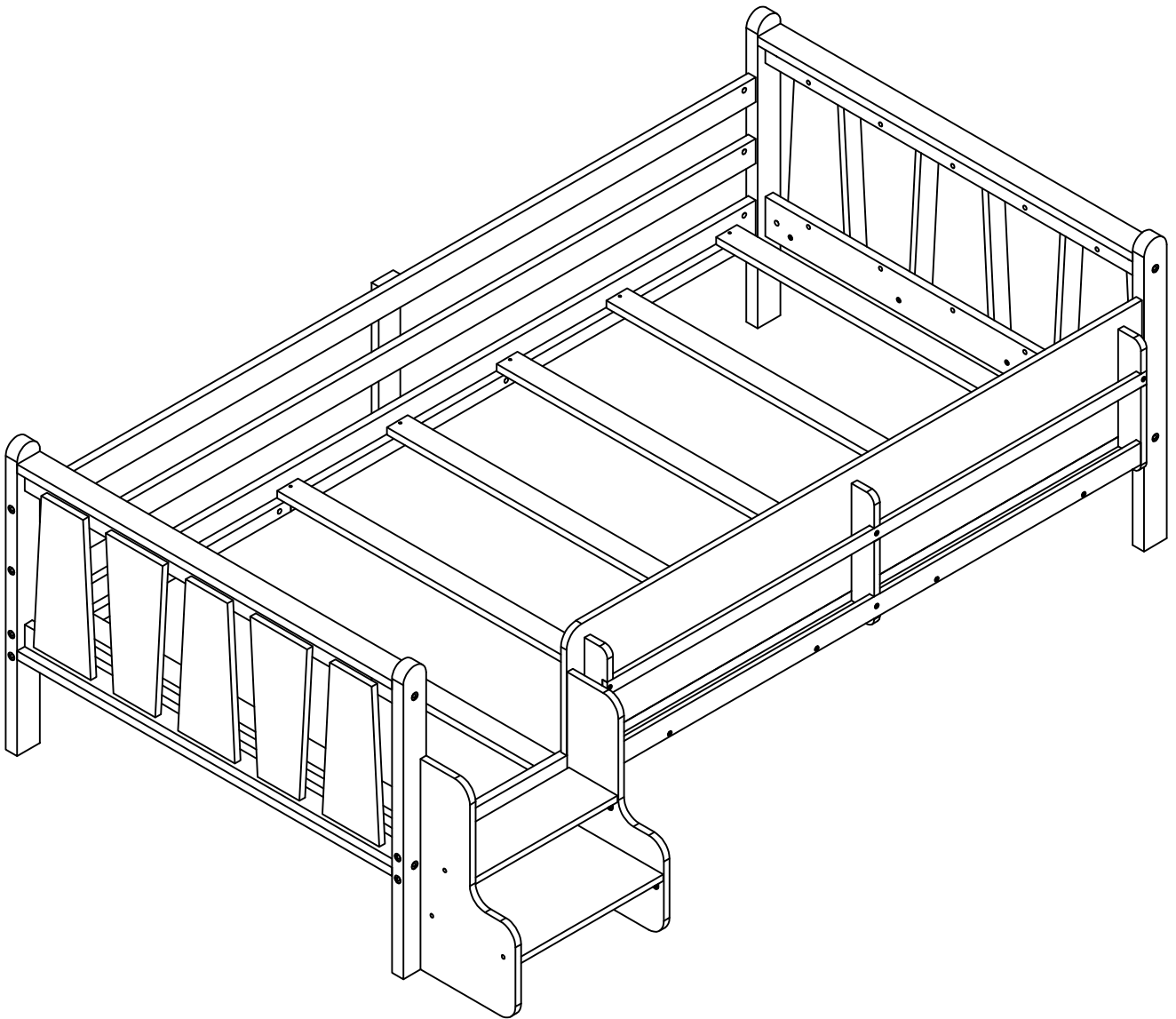

**Bed type**

**Length**

**Width**

**Thickness**

**Twin Standard**

**75"**

**38 - 38 <sup>1</sup>/<sub>2</sub>"**







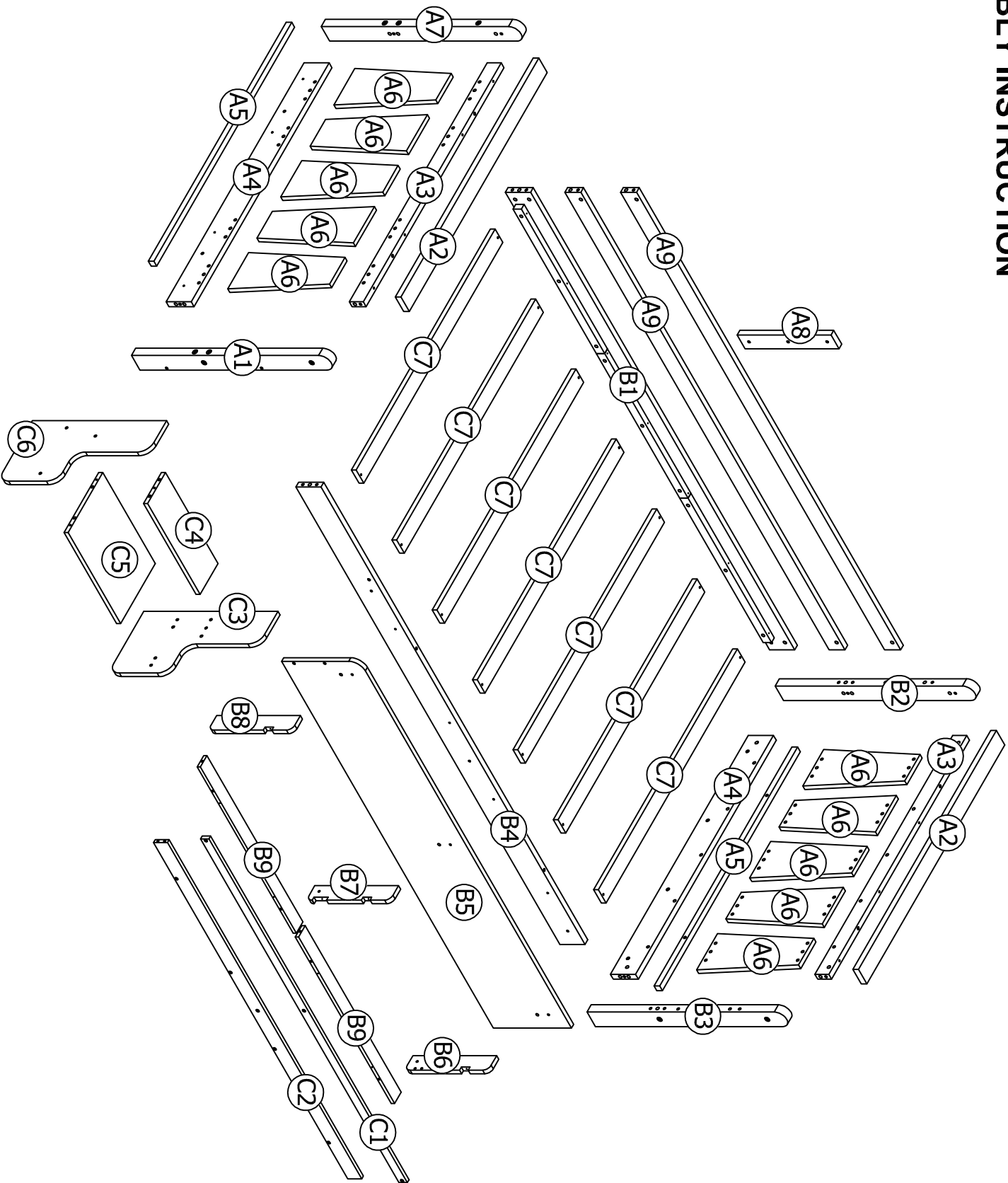

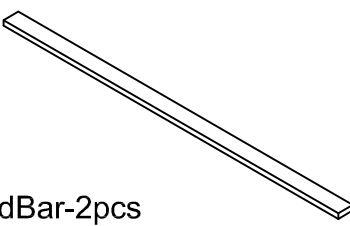
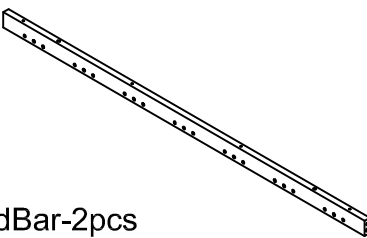
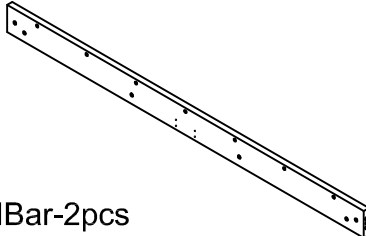
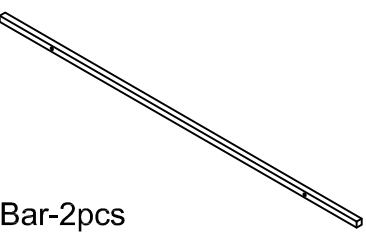

**6" max**

**This set is included 1 boxes if don't receive full 1 boxes please contact our customer service team.**

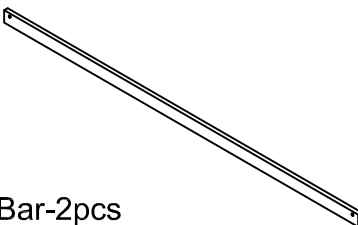
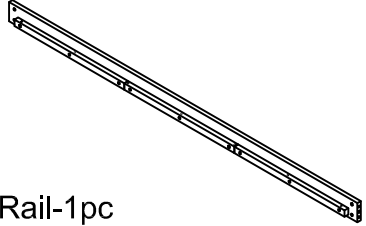
# ASSEMBLY INSTRUCTION

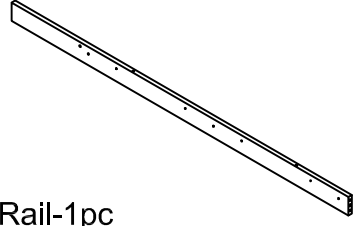
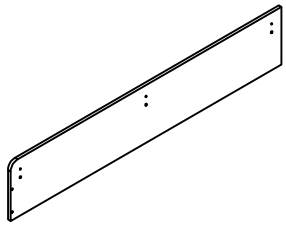

# Part List (BW00407)

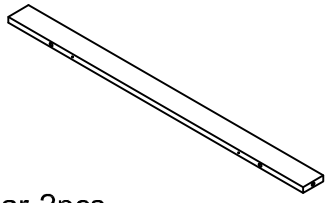
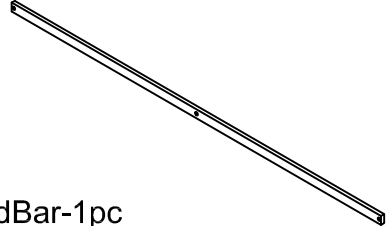
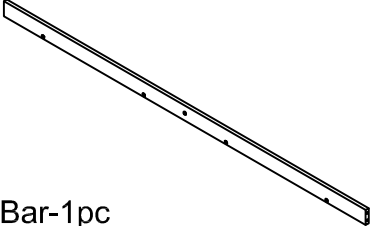
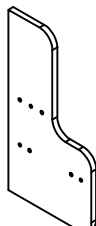
<p><b>A1</b></p>  <p>Leg-1pc</p>	<p><b>A2</b></p>  <p>WoodBar-2pcs</p>	<p><b>A3</b></p>  <p>WoodBar-2pcs</p>
<p><b>A4</b></p>  <p>WoodBar-2pcs</p>	<p><b>A5</b></p>  <p>WoodBar-2pcs</p>	<p><b>A6</b></p>  <p>Panel-10pcs</p>
<p><b>A7</b></p>  <p>Leg-1pc</p>	<p><b>A8</b></p>  <p>WoodBar-1pc</p>	<p><b>A9</b></p>  <p>WoodBar-2pcs</p>
<p><b>B1</b></p>  <p>Side Rail-1pc</p>	<p><b>B2</b></p>  <p>Leg-1pc</p>	<p><b>B3</b></p>  <p>Leg-1pc</p>
<p><b>B4</b></p>  <p>Side Rail-1pc</p>	<p><b>B5</b></p>  <p>Panel-1pc</p>	<p><b>B6</b></p>  <p>WoodBar-1pc</p>
<p><b>B7</b></p>  <p>WoodBar-1pc</p>	<p><b>B8</b></p>  <p>WoodBar-1pc</p>	<p><b>B9</b></p>  <p>WoodBar-2pcs</p>
<p><b>C1</b></p>  <p>WoodBar-1pc</p>	<p><b>C2</b></p>  <p>WoodBar-1pc</p>	<p><b>C3</b></p>  <p>Panel-1pc</p>

# Part List (BW00407)

C4

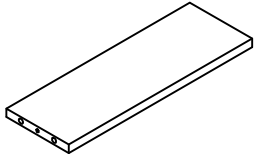

Panel-1pc

C5

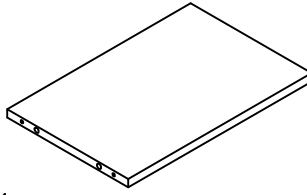

Panel-1pc

C6

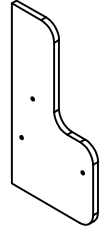





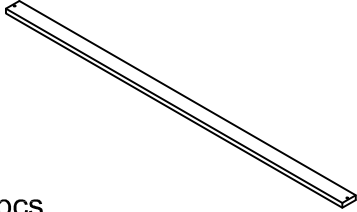

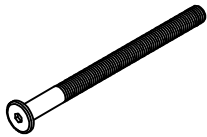
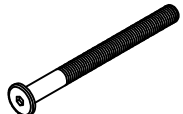

Panel-1pc

C7

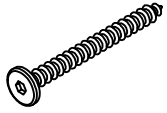
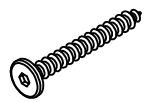
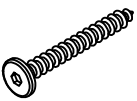
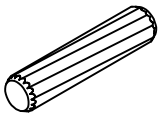
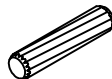

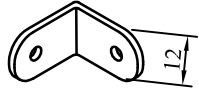
Slats-7pcs

# Hardware List (BW00407)

<p>1</p>  <p>Bolts Ø1/4" x 110 mm -13pcs</p>	<p>2</p>  <p>Bolts Ø1/4" x 80 mm -8pcs</p>	<p>3</p>  <p>Bolts Ø1/4" x 30 mm -23pcs</p>
<p>4</p>  <p>Ø1/4" x 13 mm Horizontal-Hole bolts -21 pcs</p>	<p>5</p>  <p>Screws 1/4" x60mm- 2pcs</p>	<p>6</p>  <p>Screws 1/4" x40mm- 9pcs</p>
<p>7</p>  <p>Screws 1/4" x30mm- 3pcs</p>	<p>8</p>  <p>Wood dowel Ø10 x 40 mm -20pcs</p>	<p>9</p>  <p>Wood dowel Ø8 x 25 mm - 60pcs</p>
<p>10</p>  <p>Wood dowel Ø6 x 30 mm - 18pcs</p>	<p>11</p>  <p>Steel Bracket - 8pcs</p>	<p>12</p>  <p>Wood Screws M4 x 50mm- 8pcs</p>
<p>13</p>  <p>Wood Screws M4 x 30mm- 34pcs</p>	<p>14</p>  <p>Wood Screws M3.5 x15mm-16pcs</p>	<p>15</p>  <p>Allen Key - 1pc</p>

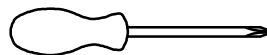

**Assembly Tools Required (Not Included)**

# STEP 1:

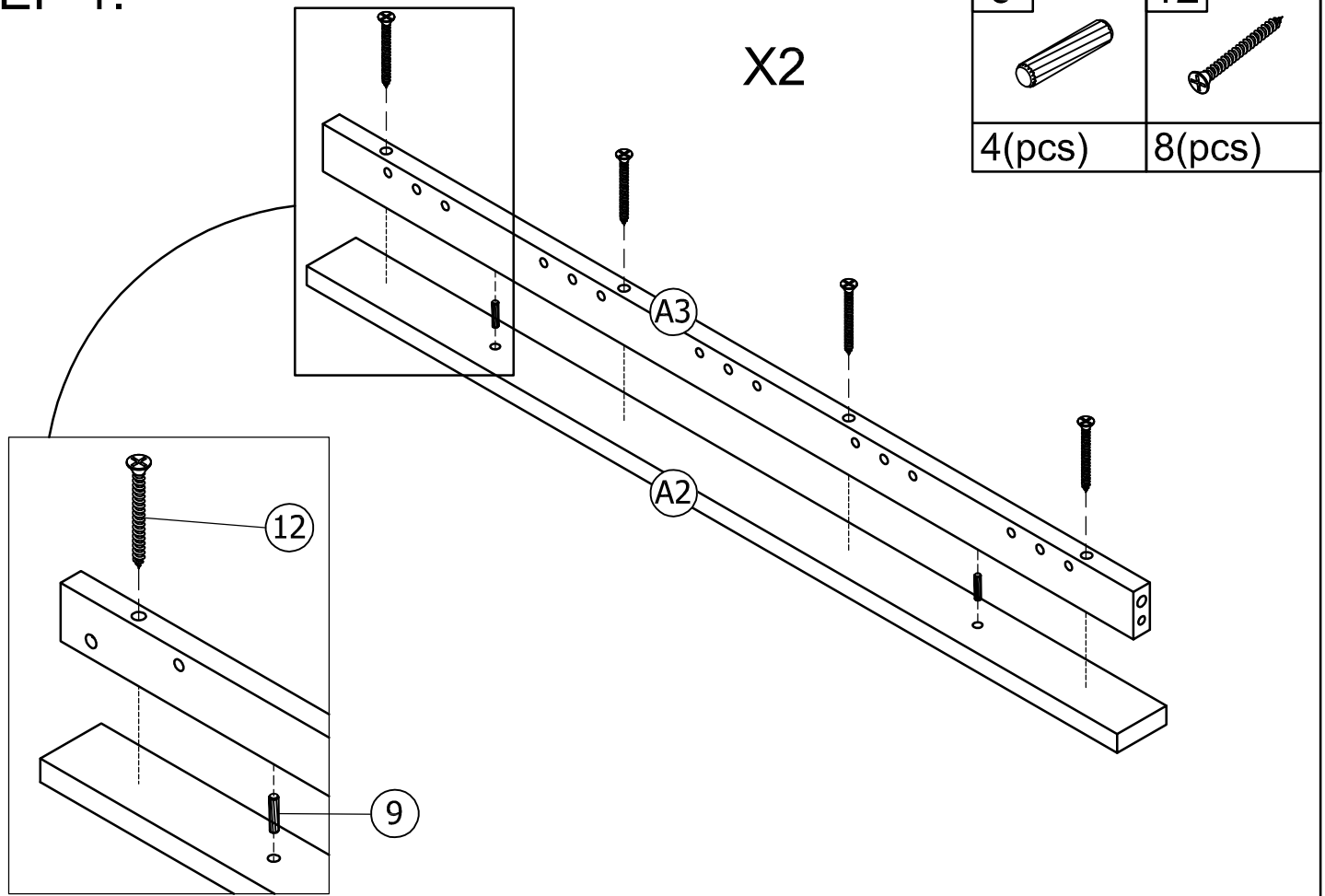

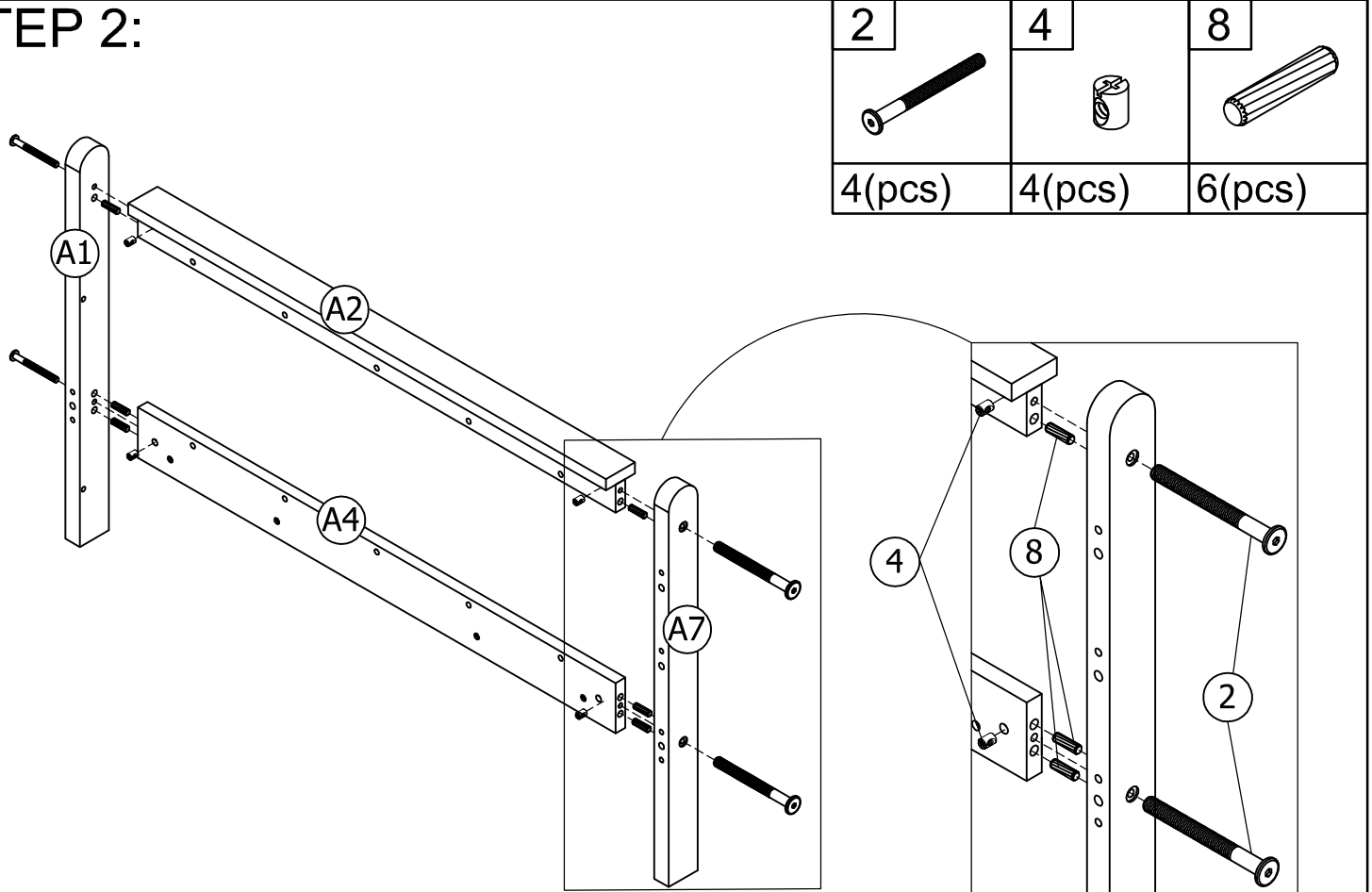

# STEP 2:



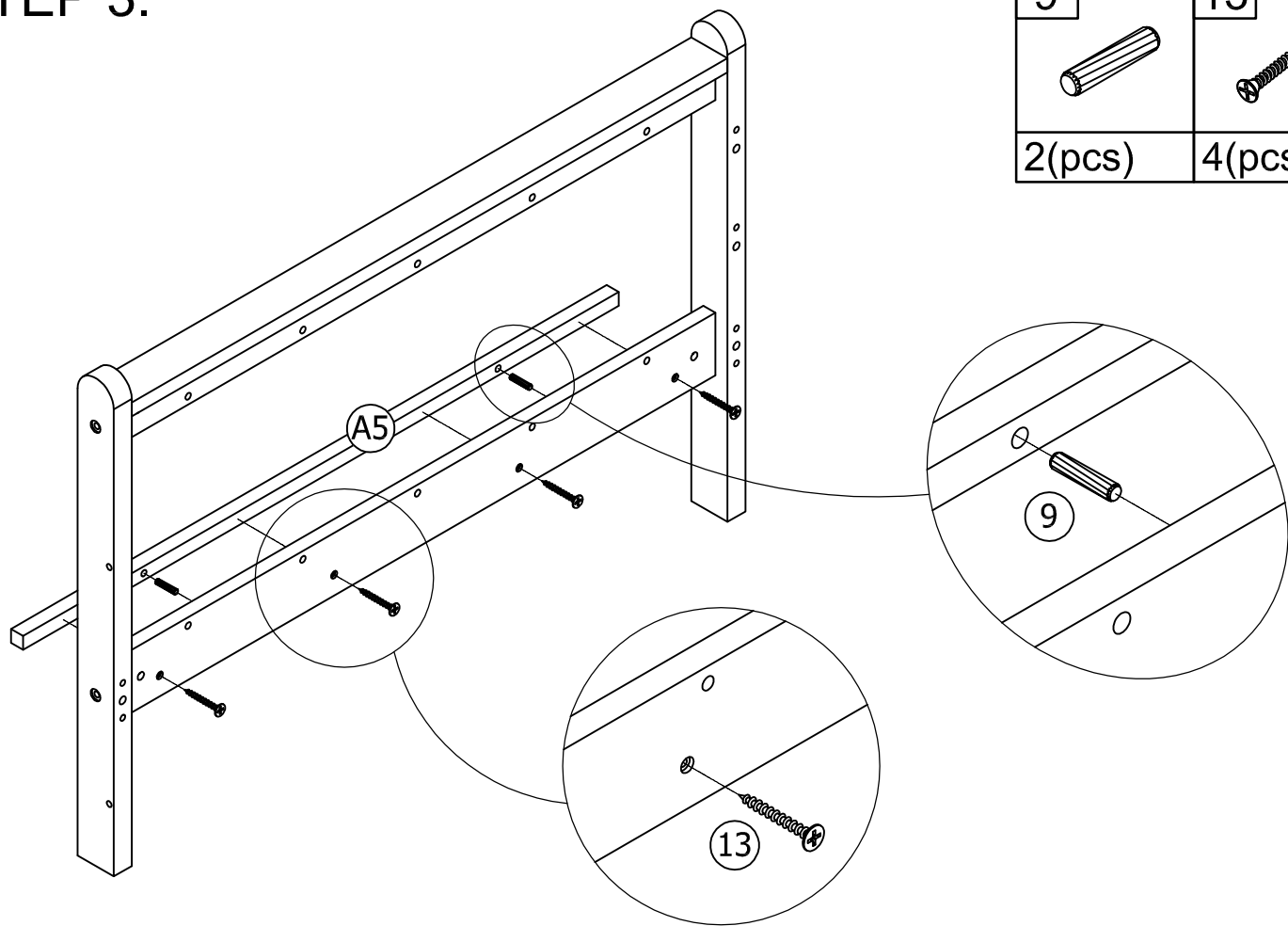

### STEP 3:



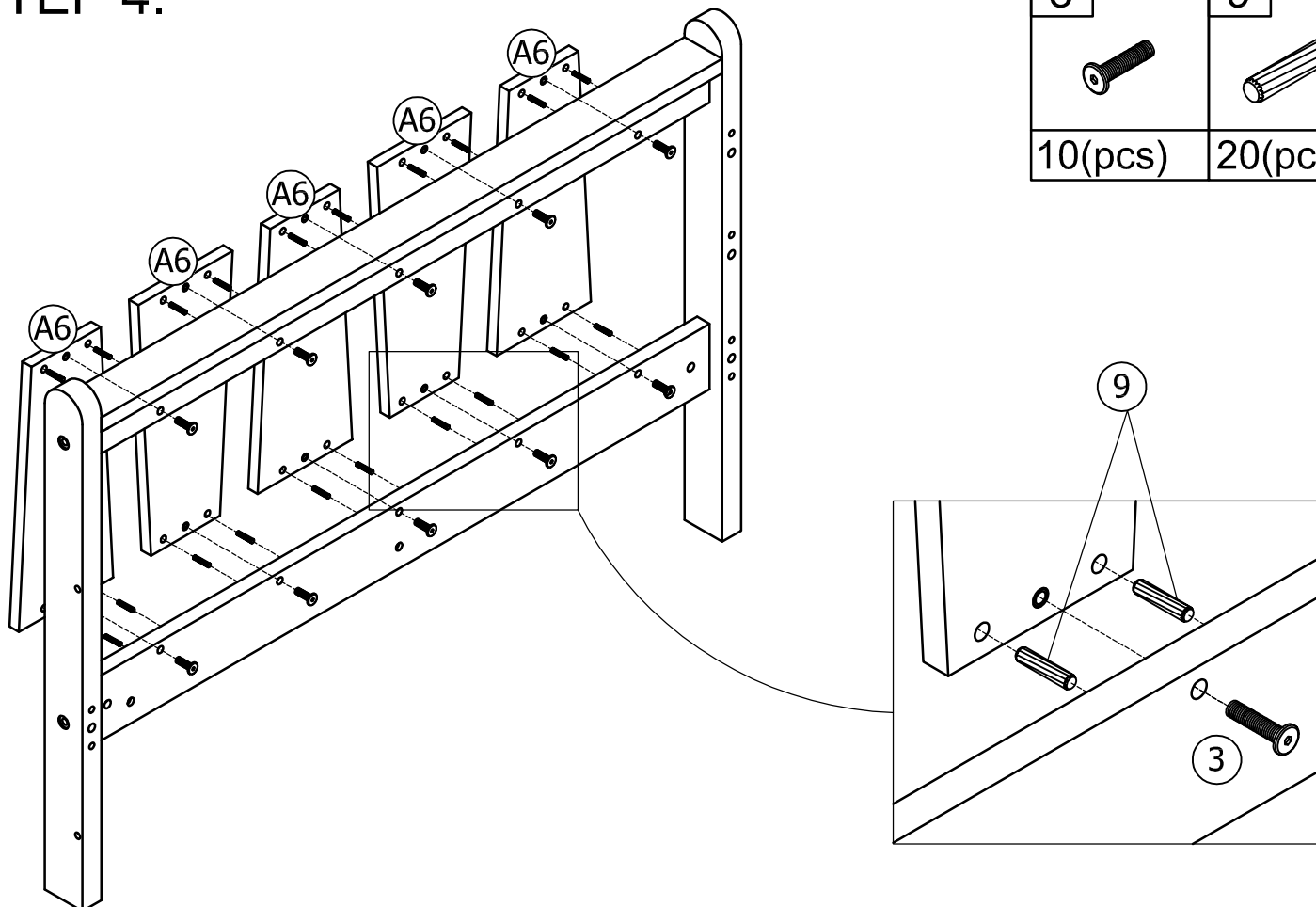

9	13
	
2(pcs)	4(pcs)

### STEP 4:



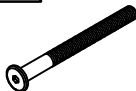

3	9
	
10(pcs)	20(pcs)

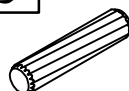
# STEP 5:

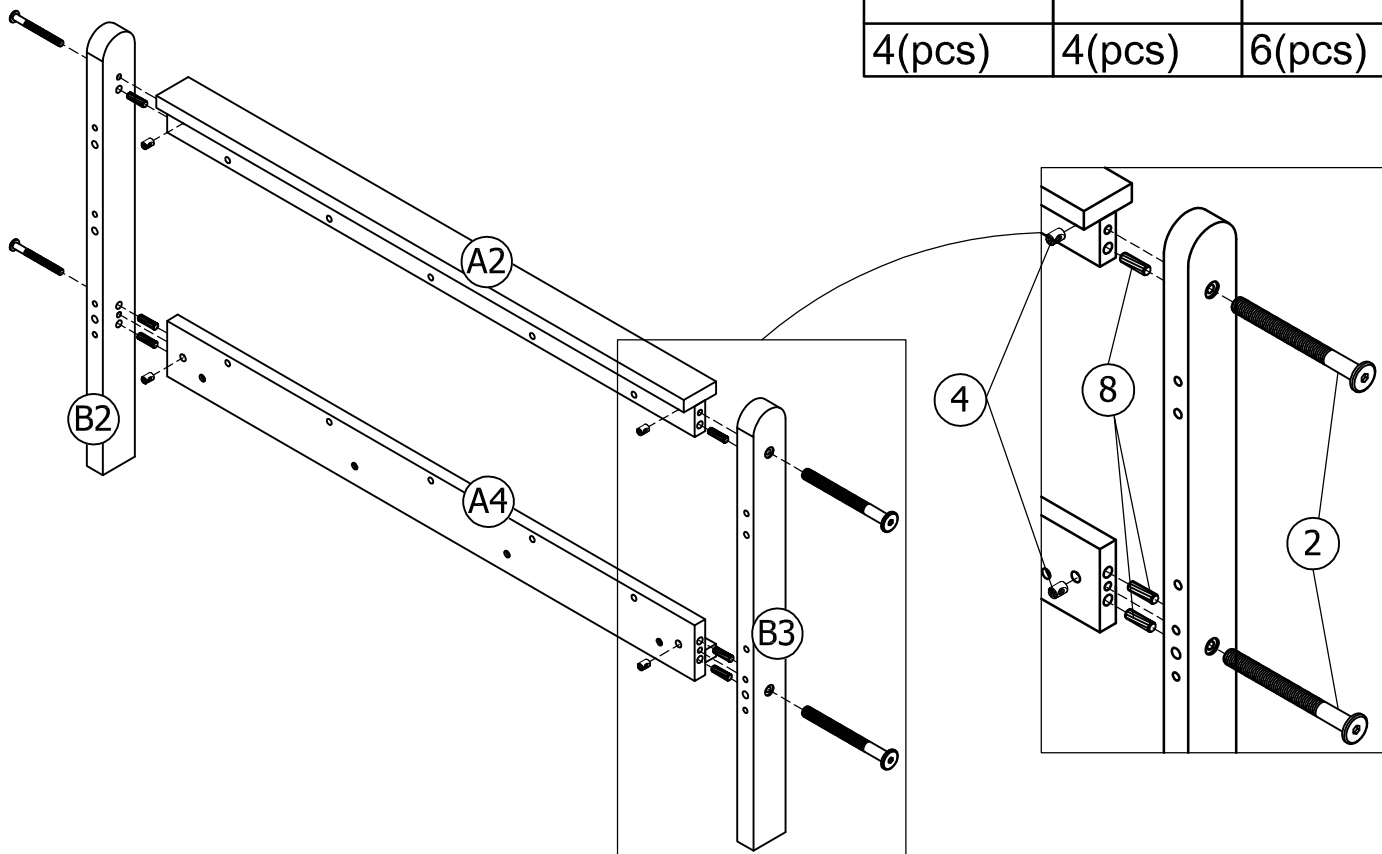
2	4	8
		
4(pcs)	4(pcs)	6(pcs)



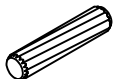

# STEP 6:

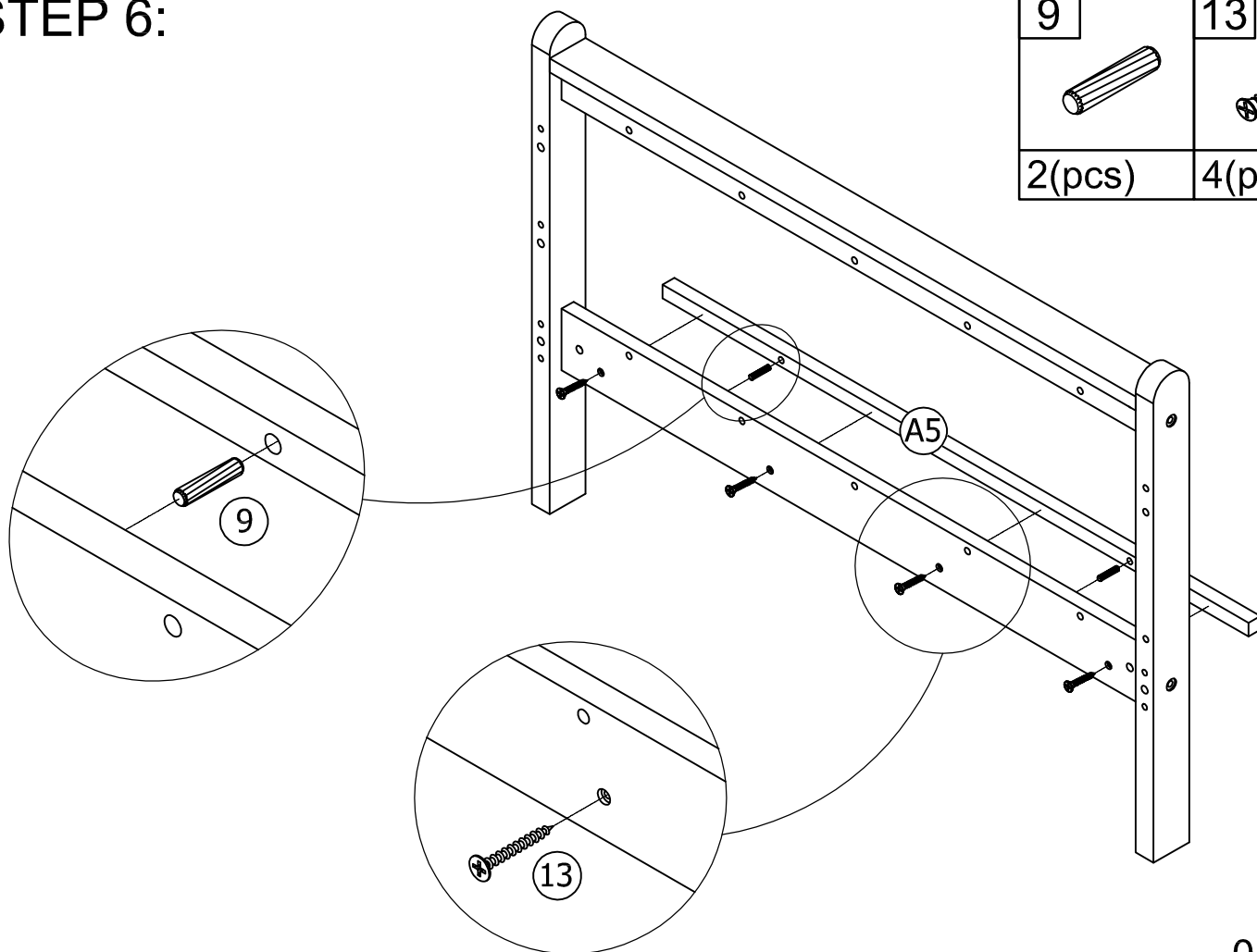
9	13
	
2(pcs)	4(pcs)



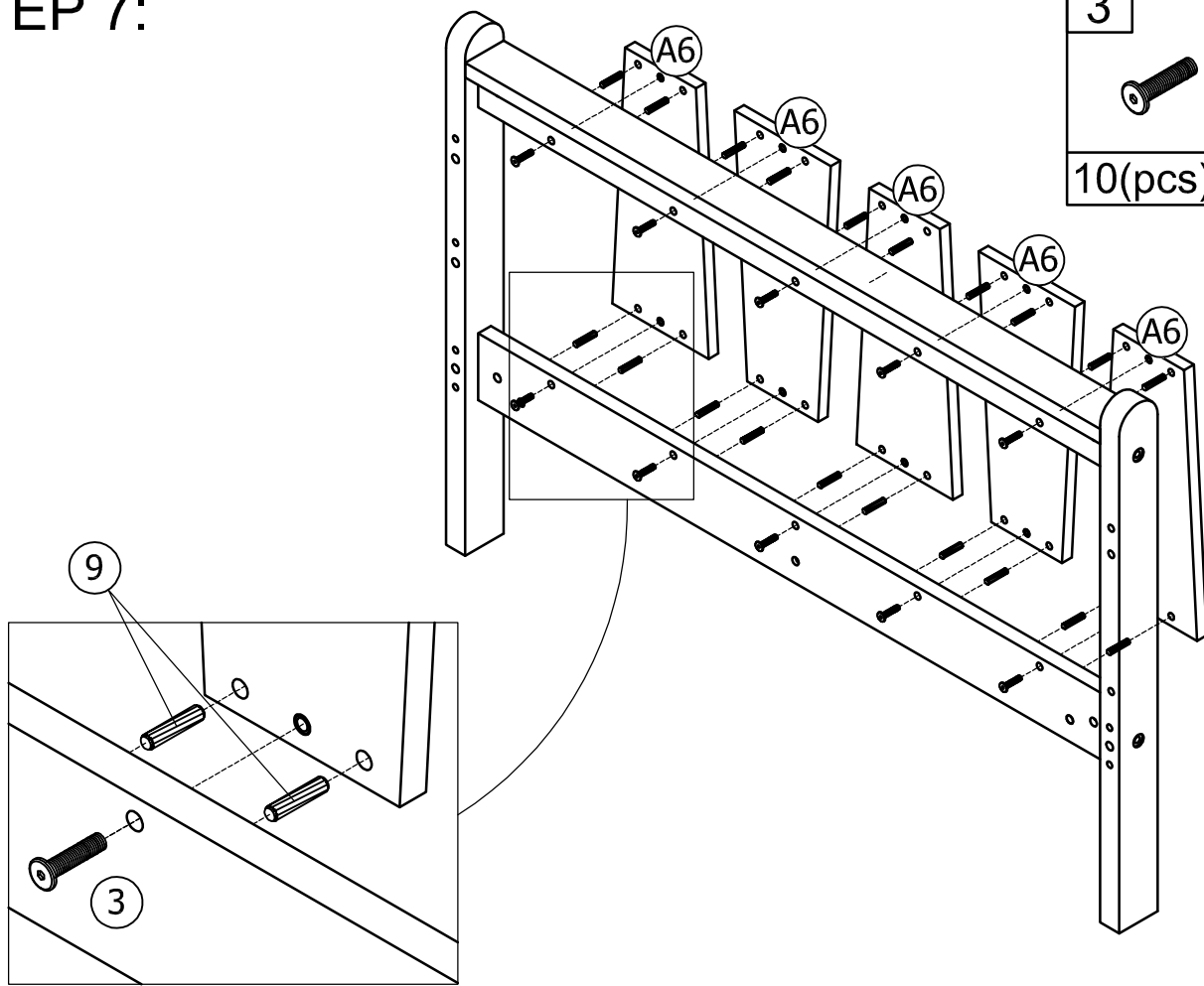

# STEP 7:

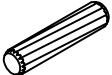

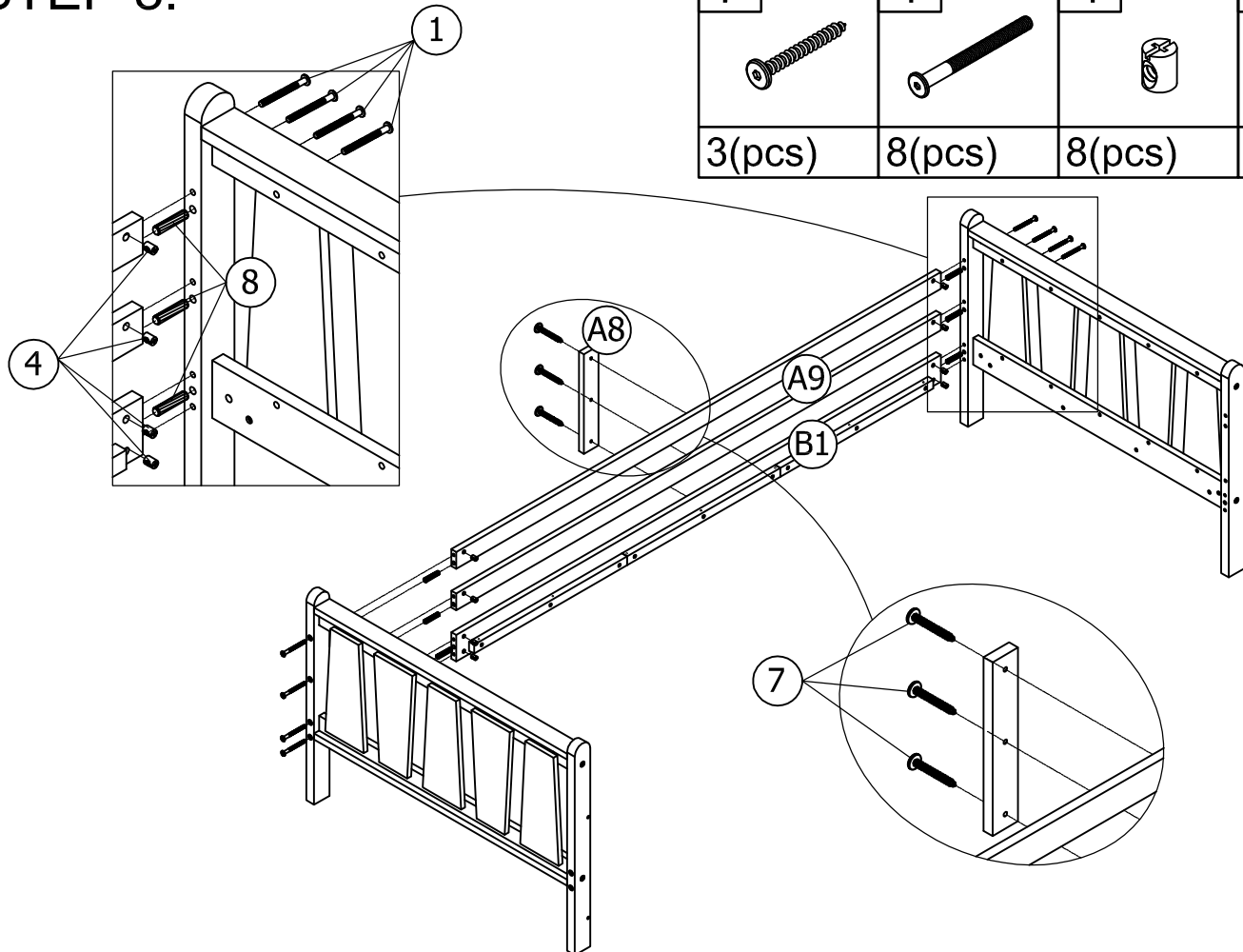

3	9
	
10(pcs)	20(pcs)

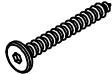
# STEP 8:

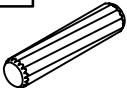

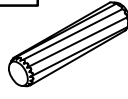

7	1	4	8
			
3(pcs)	8(pcs)	8(pcs)	6(pcs)

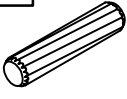
# STEP 9:

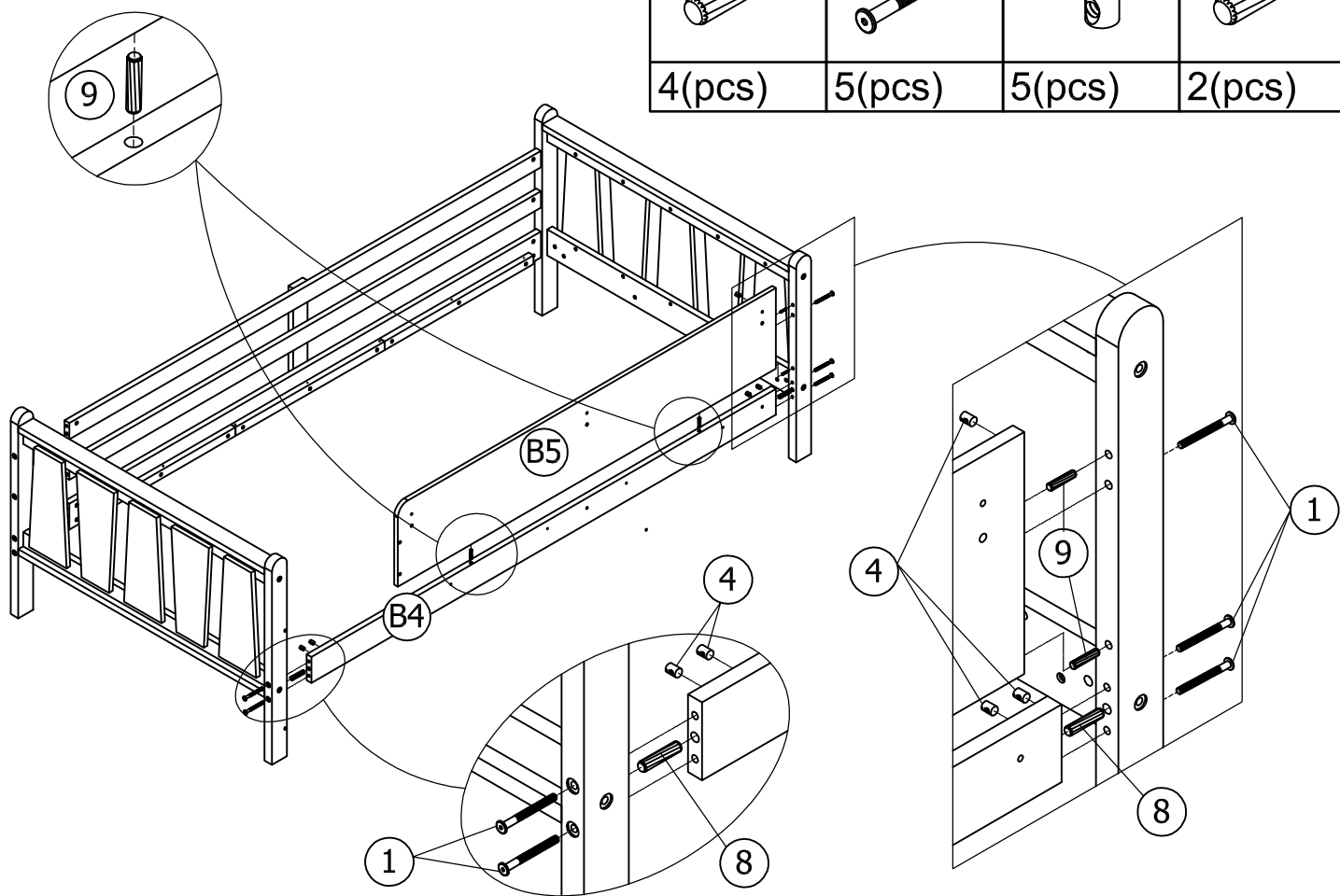
9	1	4	8
			
4(pcs)	5(pcs)	5(pcs)	2(pcs)

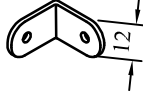

# STEP 10:

11	14
	
4(pcs)	4(pcs)

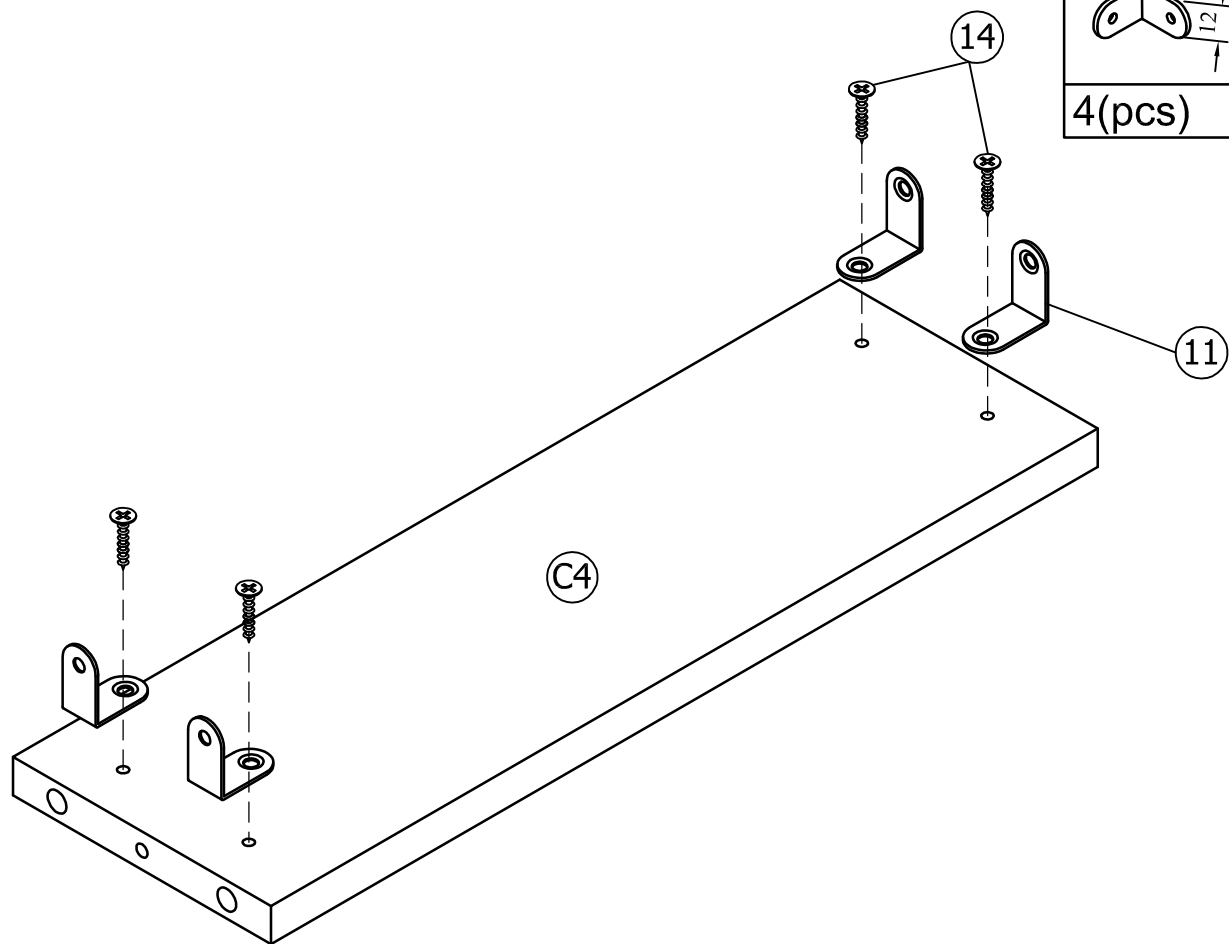

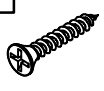

# STEP 11:

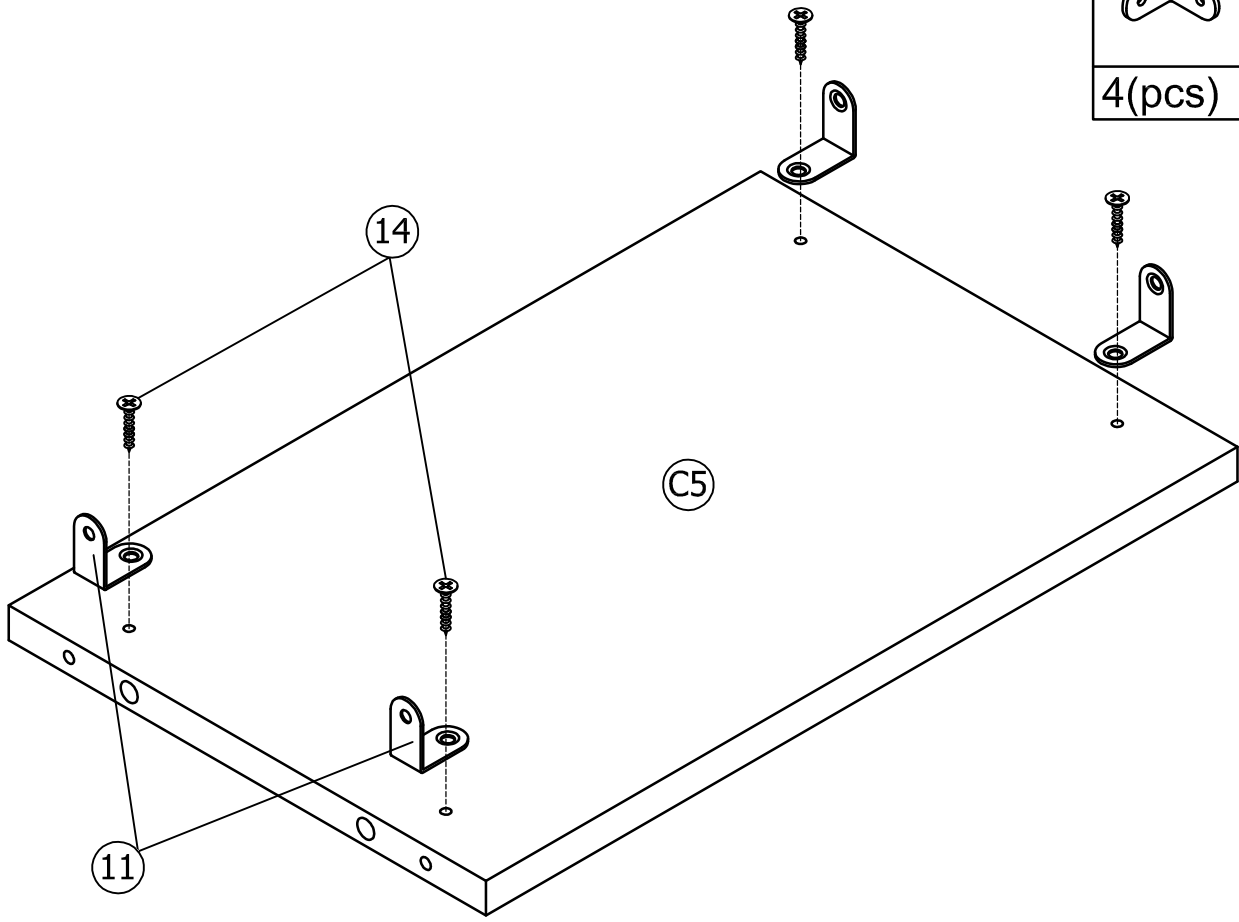
11	14
	
4(pcs)	4(pcs)

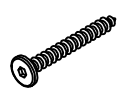

# STEP 12:

6	9
	
6(pcs)	8(pcs)

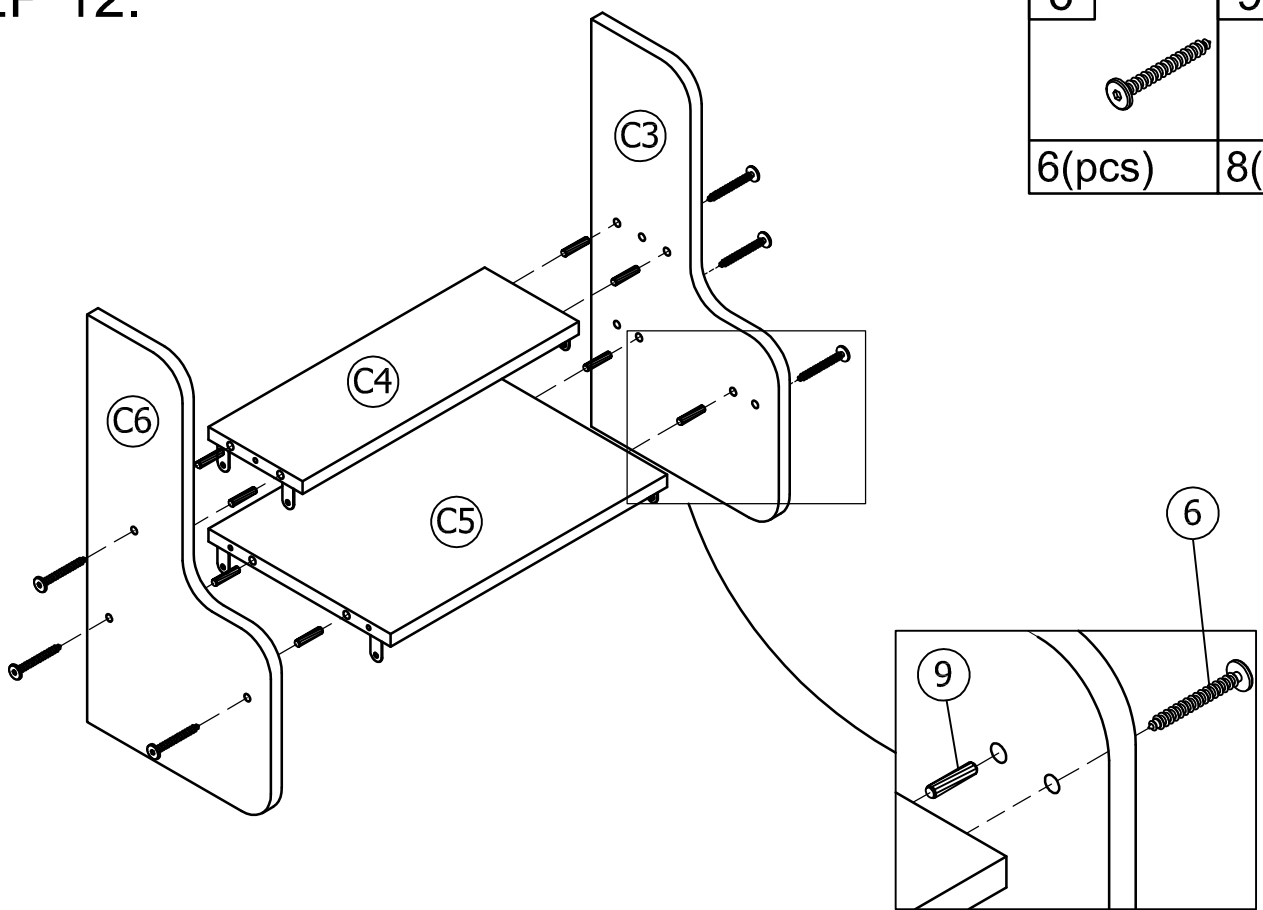

# STEP 13:

14



8(pcs)

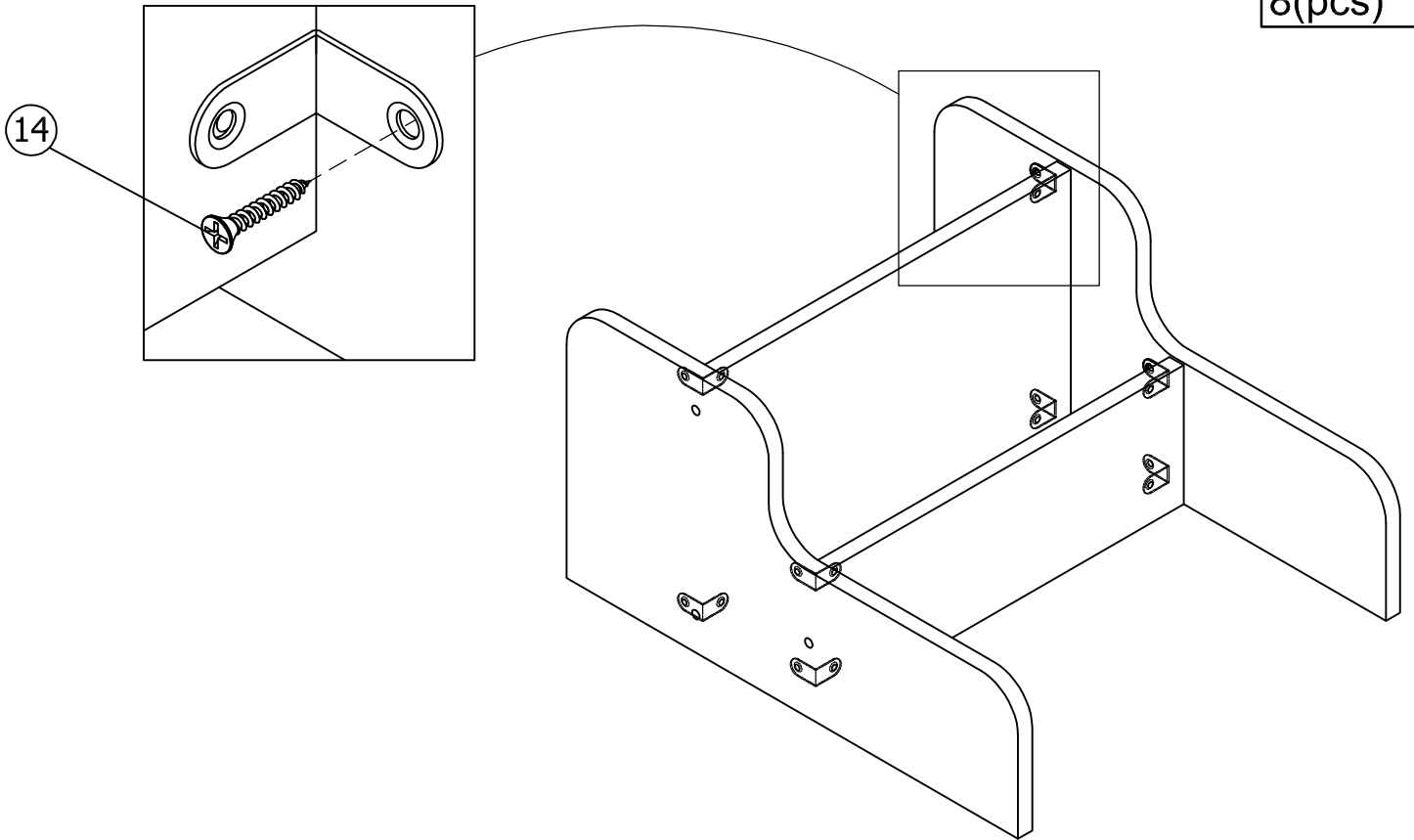

# STEP 14:

10



6(pcs)

13



5(pcs)

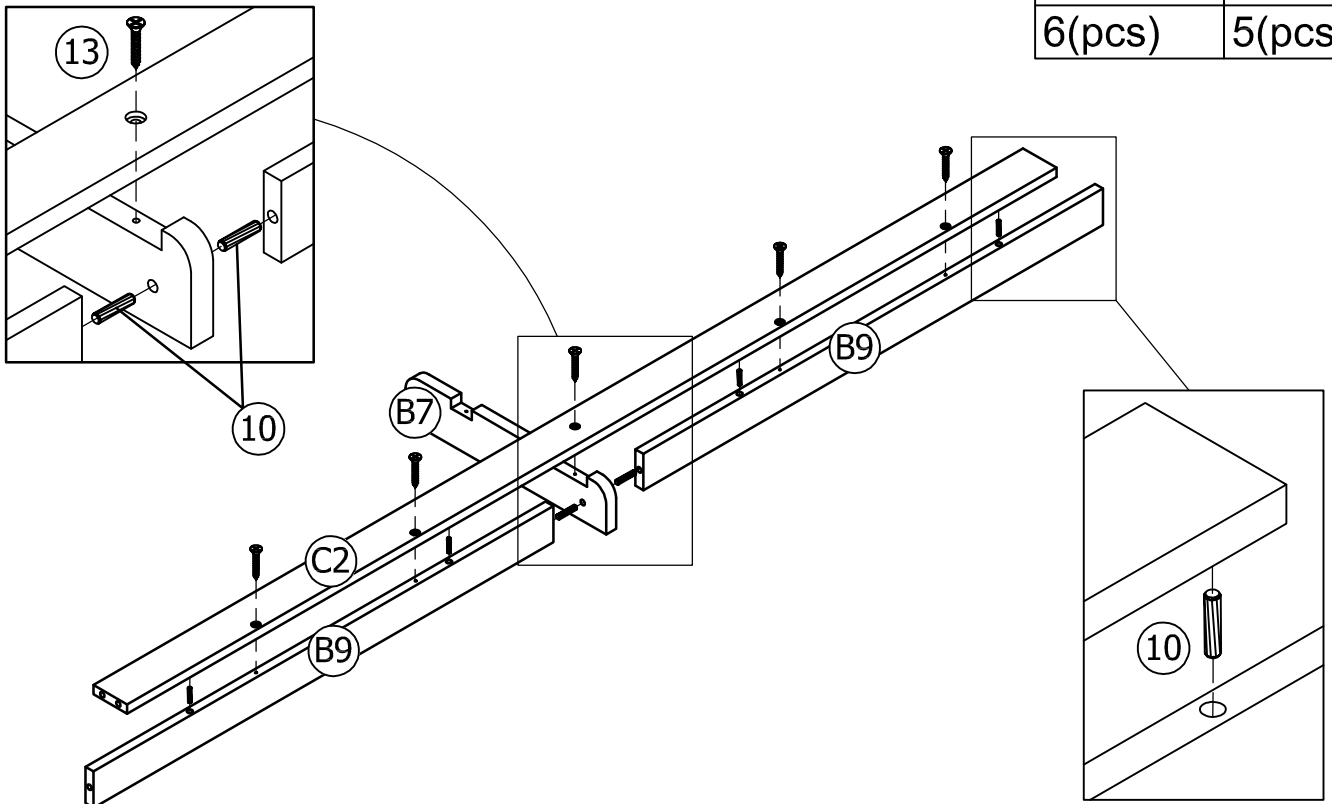

# STEP 15:

10



6(pcs)

13



3(pcs)

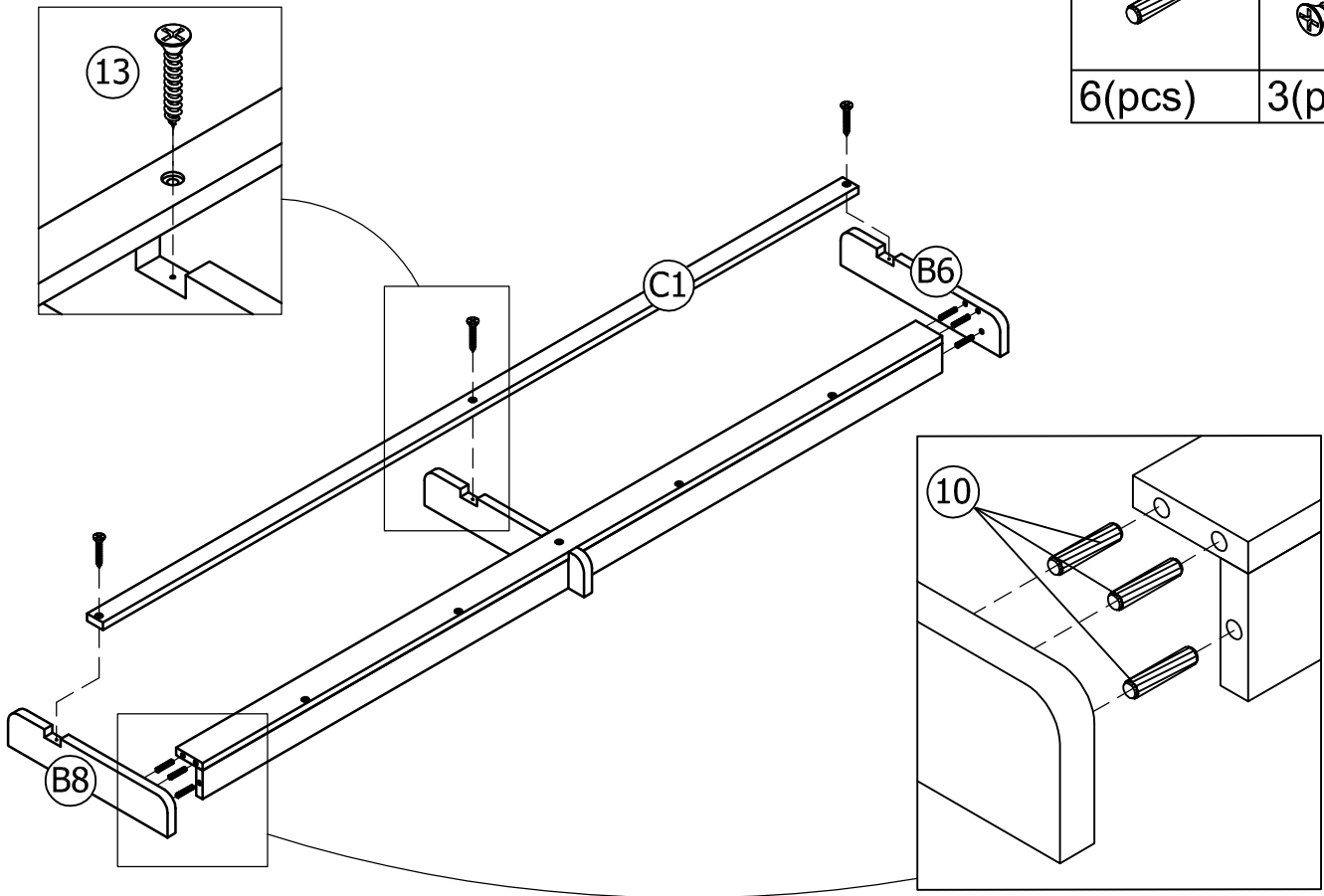

# STEP 16:

10



6(pcs)

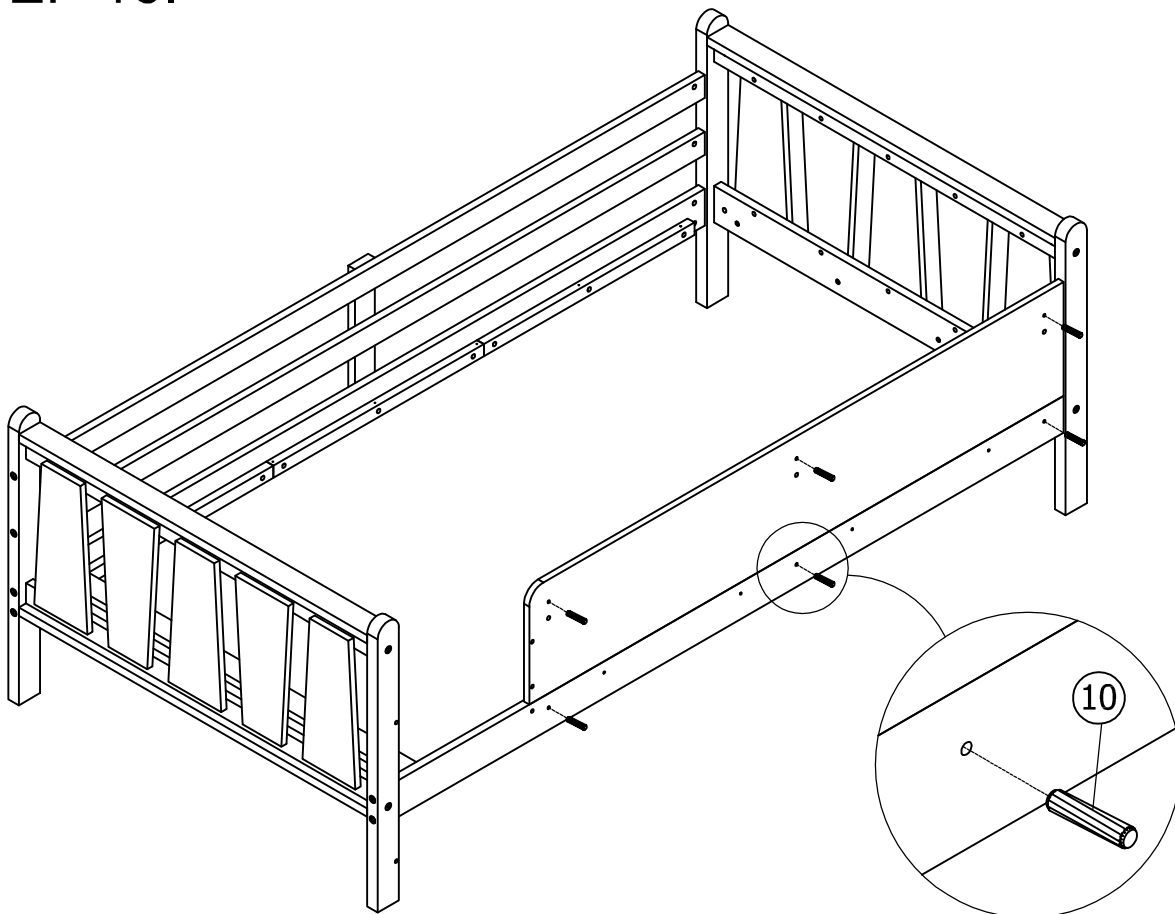

# STEP 17:

3



3(pcs)

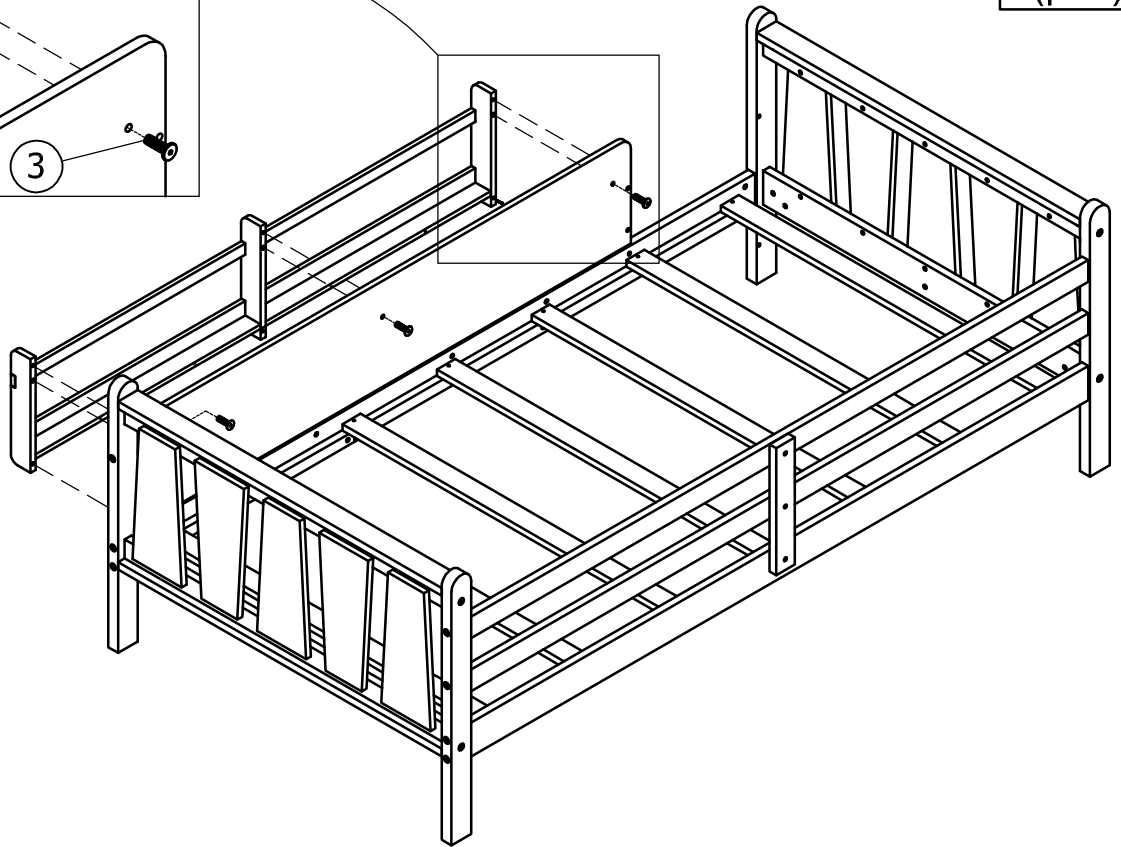
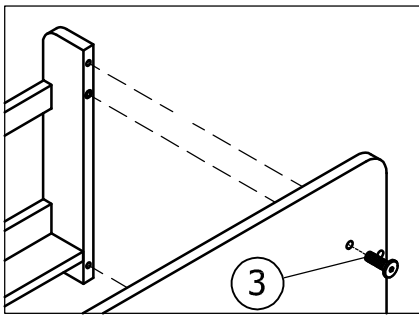

# STEP 18:

13

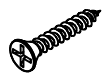

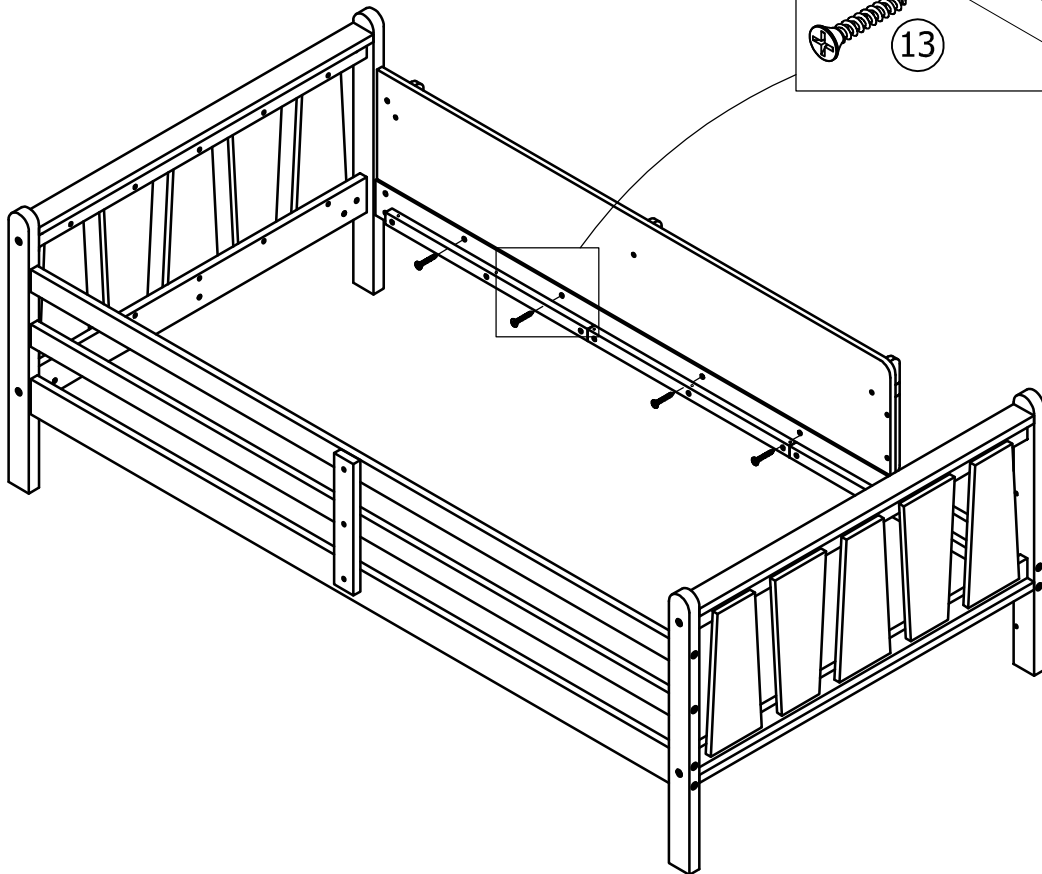
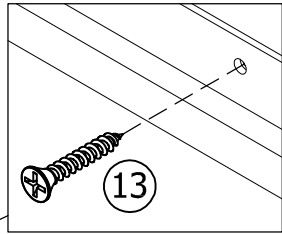

4(pcs)

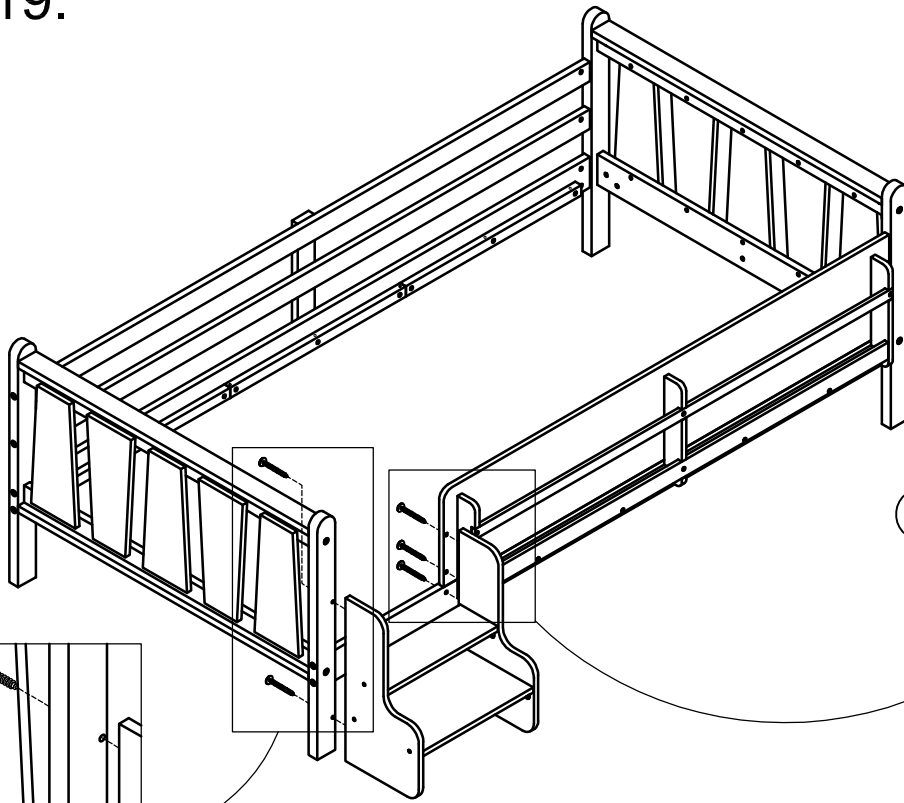

# STEP 19:

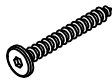

5	6
	
2(pcs)	3(pcs)

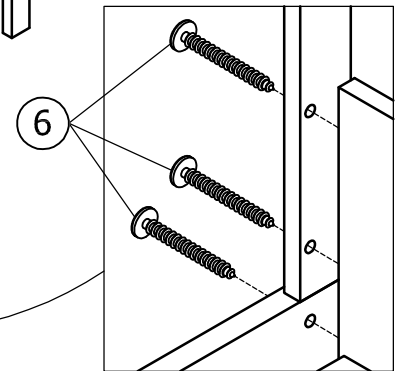
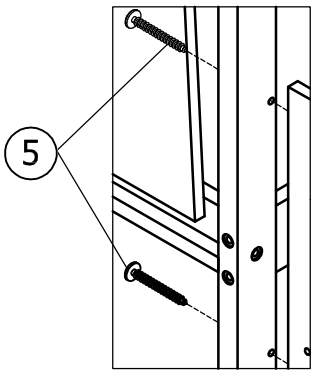

# STEP 20:

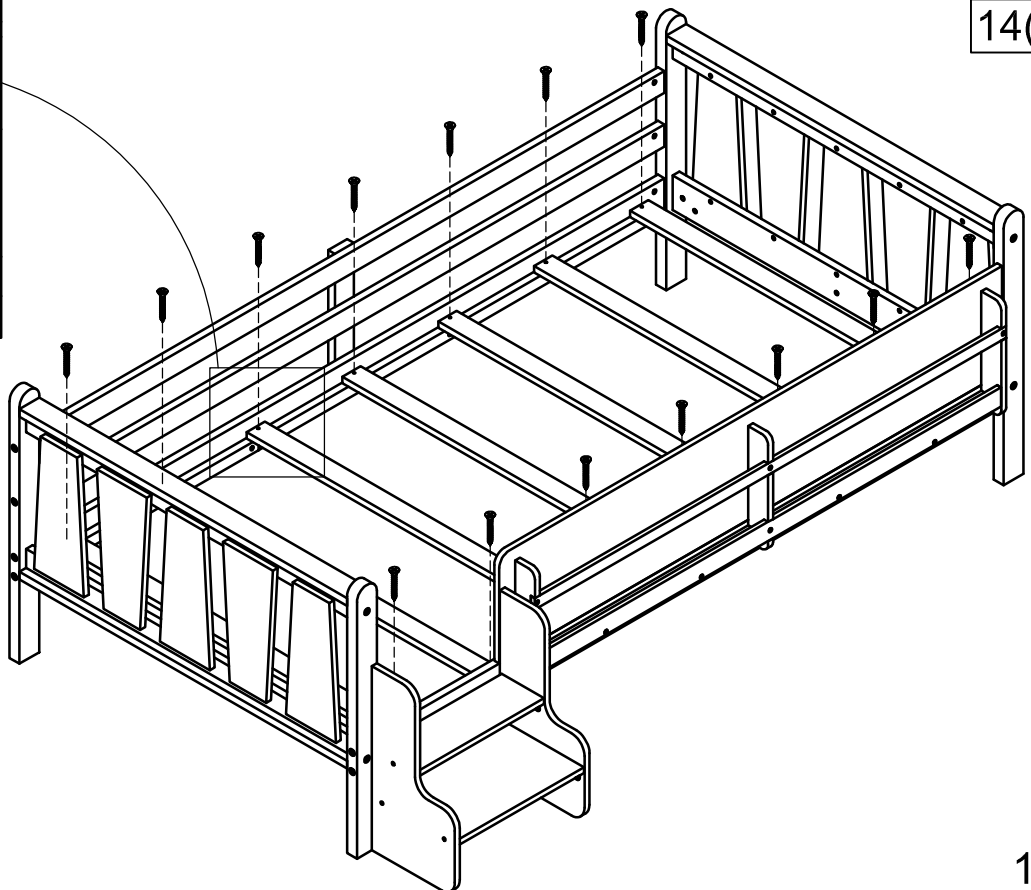
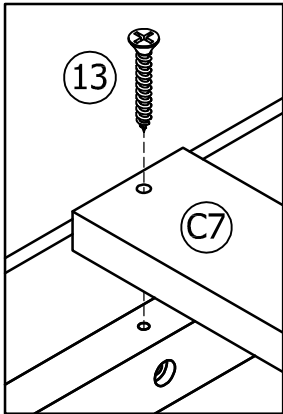

13

14(pcs)

**FINISH:**

