

ASSEMBLY INSTRUCTIONS

TIFFANY DROP LEAF TABLE

ASSEMBLY
REQUIREMENTS

2-Person
Assembly

Assembly Time
(Approximate) : 30 Minutes

Tools Required : Philips Screwdriver
(Not Provided) : 

PRODUCTS PURCHASED THROUGH OUR AUTHORIZED VENDORS ONLY ARE ELIGIBLE FOR REPLACEMENT PARTS

We appreciate your business!

THIS PRODUCT IS FOR INDOOR AND HOUSEHOLD USE ONLY - NOT FOR COMMERCIAL USE

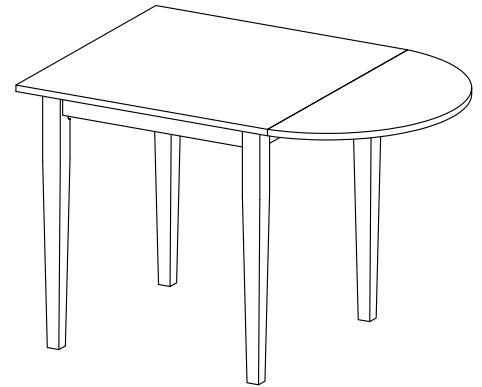

ASSEMBLY PREPARATION

1. Remove all packaging materials, staples and packing straps from the carton.
2. Refer to Parts List and Hardware List, and ensure parts and hardware are correct before assembly. Contact customer service for missing parts.
3. Place all wooden parts on a clean, flat and soft surface (e.g. carpet or rug) to prevent scratch and damage to parts.

SAFETY PRECAUTION

1. KEEP ALL HARDWARE PARTS OUT OF REACH OF CHILDREN.
2. DISPOSE PLASTIC PACKAGING MATERIAL IMMEDIATELY TO AVOID ANY RISK OF SUFFOCATION TO CHILDREN AND ANIMALS.









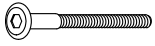

TIPS FOR ASSEMBLY

1. Allow ample room for assembly and assemble the product near where the product will be placed.
2. Assemble the product on a surface that does not scratch or damage the exterior gloss and finish of the furniture.
3. Identify all of the parts, hardware and quantities required for each step.
4. During assembly, do not over-tighten any fittings as this may cause damage.
5. DO NOT USE POWER TOOLS TO ASSEMBLE THIS PRODUCT.
6. Always place the product on a flat, level surface.
7. Do not sit or stand on the partially assembled product; only use the product for which it is intended.

CARE AND MAINTENANCE

- Wipe clean with a soft, dry cloth; avoid the use of harsh chemicals or household cleaners as they may damage the exterior finish of the furniture.
- Hardware may loosen over time. Periodically, check that all connections are tight; re-tighten as necessary.
- Solid wood is impacted by heat and humidity fluctuations and may result in small joint separations or hairline cracks; place the furniture away from direct sunlight and air conditioning vents, heating vents or units to protect the furniture.

ASSEMBLY INSTRUCTIONS TIFFANY DROP LEAF TABLE

Parts List				Hardware List				
NO.	DESCRIPTION	PART	QTY	NO.	DESCRIPTION	PART	QTY	EXTRA
1	TABLE TOP		1 PC	A	JCBC BOLT M6 X 60MM		8 PCS	1 PC
2	LEAF TOP		1 PC	B	FLAT WASHER		8 PCS	1 PC
3	TABLE LEG		4 PCS	C	SPRING WASHER		8 PCS	1 PC
4	RUNNER RAIL		2 PCS	D	M4 ALLEN KEY		1 PC	
				E	M3.5 X 16MM CHIPBOARD SCREW		16 PCS	1 PC
				F	HINGE		3 PCS	
				G	PLATE STOPPER		2 PCS	
				H	NAIL LEG			2 PCS

*Extra Hardware For Spare Use

STEP 1

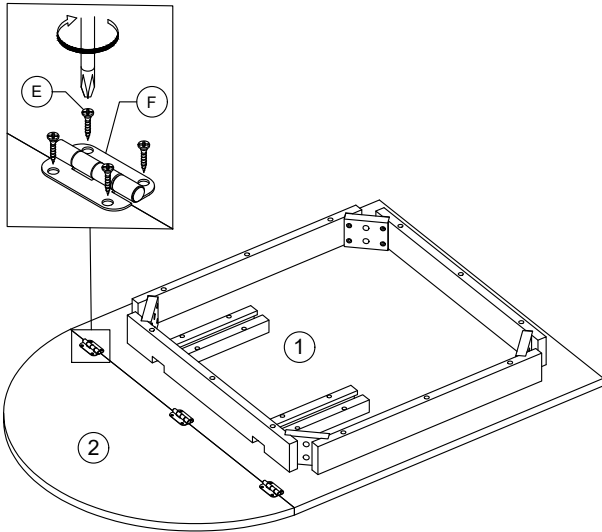

STEP 2

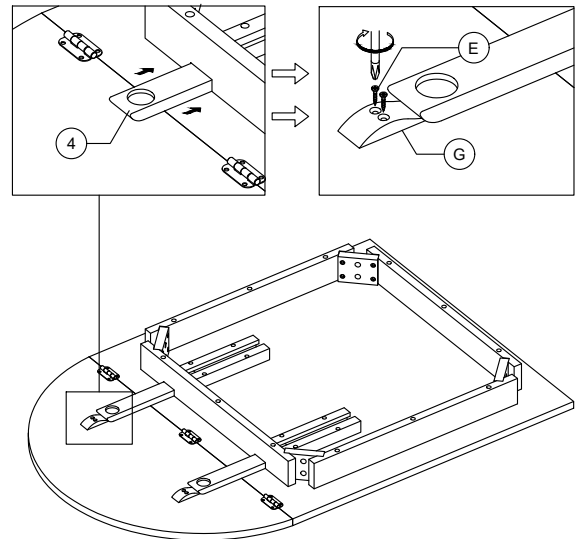

STEP 3

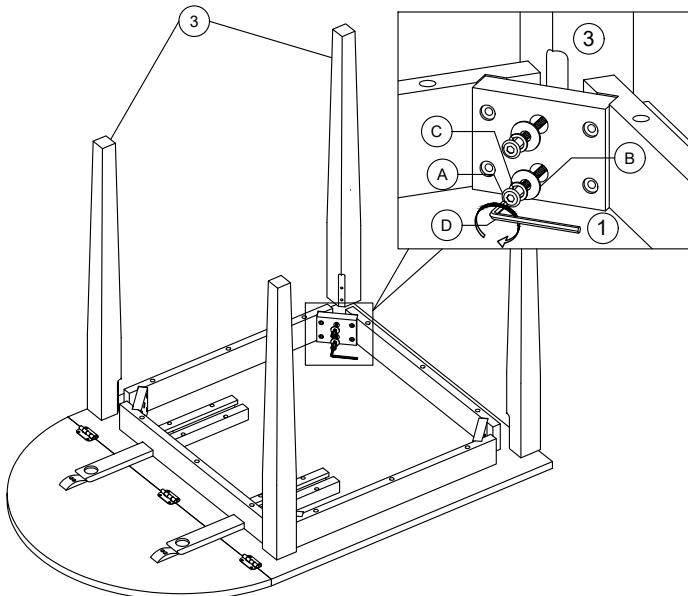

STEP 4

