

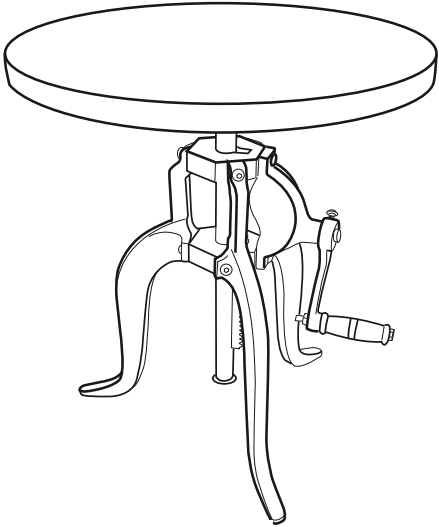

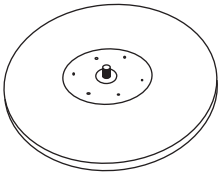



Assembly Instructions

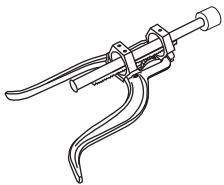

NOTE:
 When attaching leg in Step 1 if the holes do not line up, Loosen the top bolt of the other 2 legs, adjust middle hexagonal piece and then retighten top bolts.
 Do not completely remove bolt of other 2 legs

NO.	PART	DESCRIPTION	Q'TY	NO.	PARTS	DESCRIPTION	Q'TY
A		Top	1PC	B		Leg	1PC
C		Base	1PC	D		Handle	1PC
E		Allen Head Bolt 8mm 20mm	3PCS	F		Allen Head Wrench 5mm	1PC
G		Knob	1PCS				

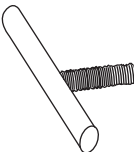
Assembly Instructions

STEP 1

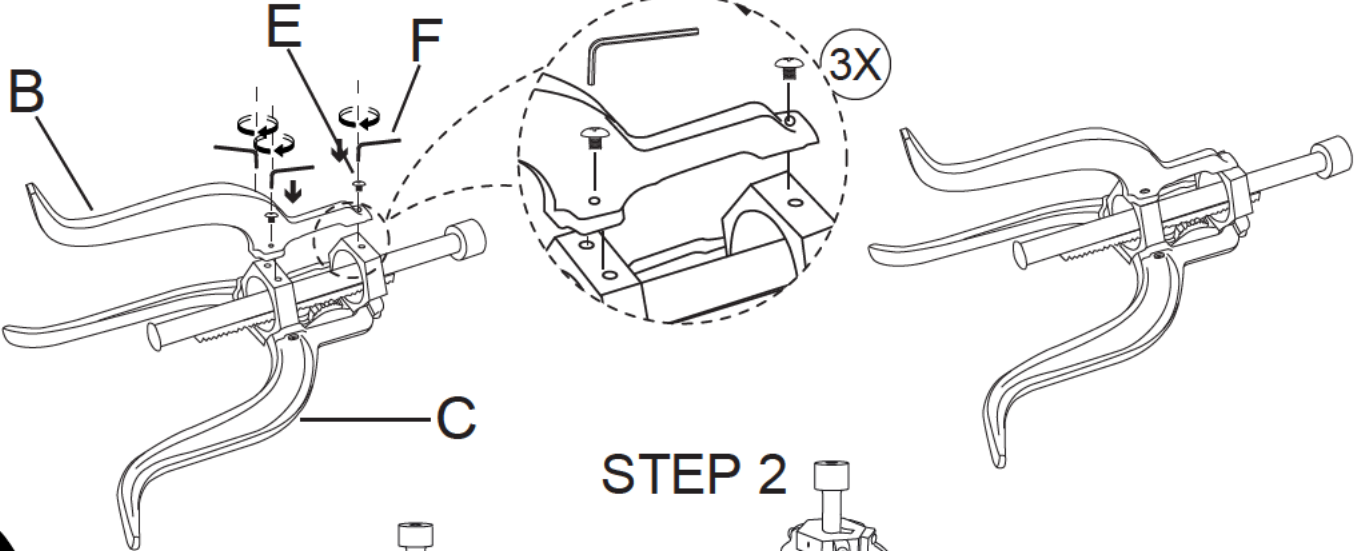

STEP 2

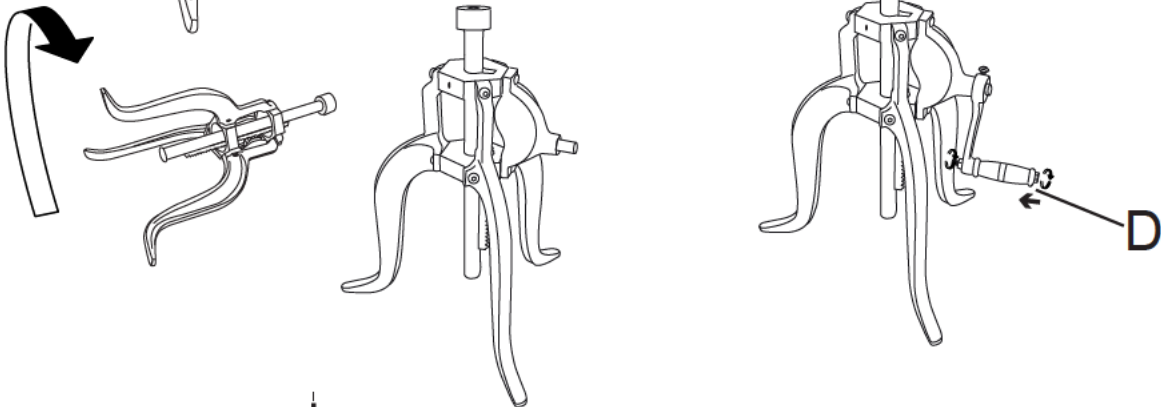

STEP 3

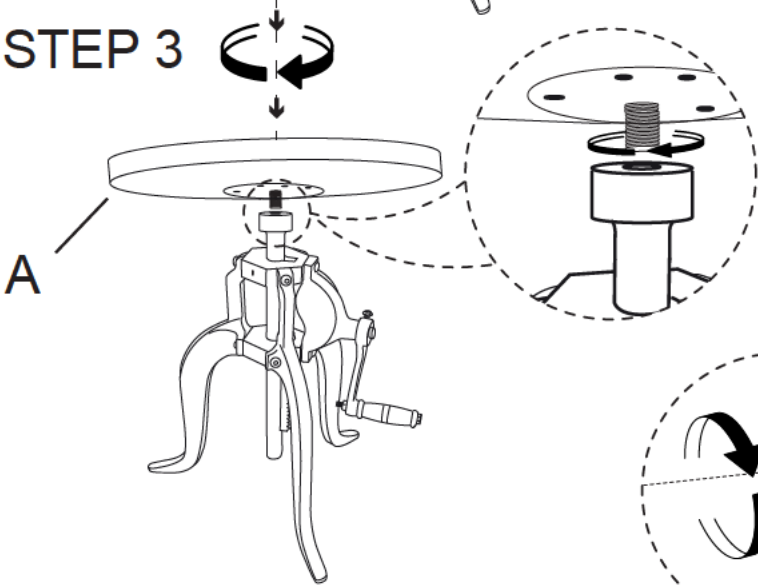

STEP 4

