

ASSEMBLY INSTRUCTIONS

979-915 End Table

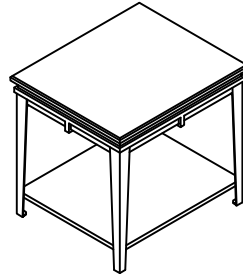

TOOLS REQUIRED:

Phillips Head Screwdriver (Not Provided)





BEFORE YOU START:

1. Check the parts against the parts list to make sure all items are present.
2. Assemble your furniture on a soft, flat surface to avoid scratching the finish.
3. **CAUTION:** Do not over tighten screws, nuts or bolts during assembly.
4. Your furniture may require occasional tightening.

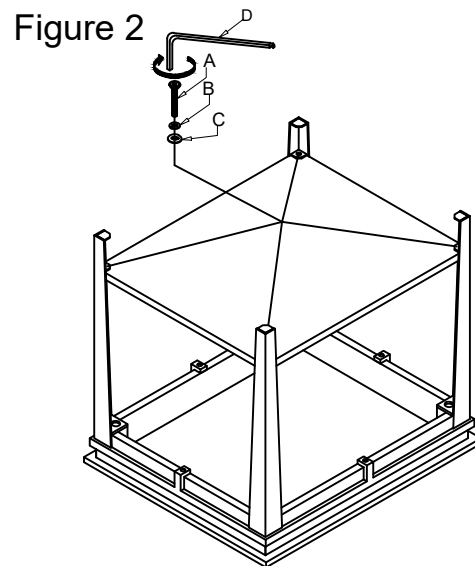
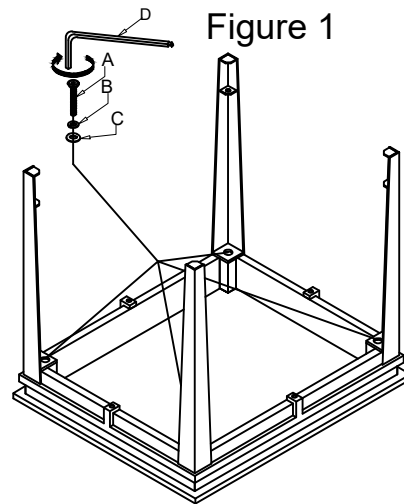
INSTRUCTIONS:

1. Turn the table top upside down on to a clean soft surface.
2. Attach legs to the table with Bolt (A), Lock washer (B) and Flat washer (C). Tighten all bolts with Allen key (D). (See Figure 1)
3. Install shelf into slot of legs, align pre-drilled holes in base with hole in bottom of Legs, using Flat Washer (C), Lock Washer (B), Bolt (A) and tighten all with Allen key (D). (See Figure 2)



No.	Hardware List	Q'ty
A	 Bolt Ø1/4 x L3/4"	16
B	 Lock Washer Ø1/4"x11mm	16
C	 Flat Washer Ø1/4"x18mm	16
D	 Allen key 4mm	1