

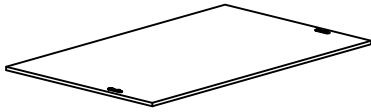

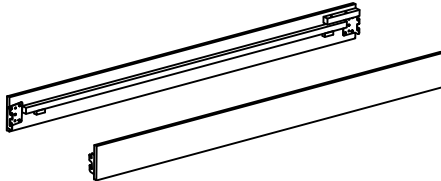

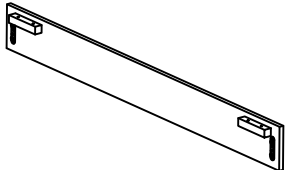

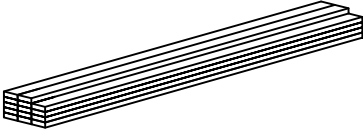

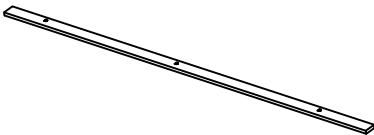



Product Assembly Instructions

PART LIST

 <p>A: HEADBOARD x1</p>	 <p>B: SIDERAIL (L&R) x2</p>	 <p>C: FOOTBOARD x1</p>
 <p>D: SLAT x14</p>	 <p>E: CENTER SLAT x1</p>	 <p>F: CENTER SLAT SUPPORT x3</p>
 <p>G: LEG x2</p>	 <p>H: LEG SUPPORT x2</p>	

HARDWARE LIST

 <p>I: JCBB SCREW M8 x 16mm x8</p>	 <p>J: ALLEN KEY M5 (SHORT) x1</p>	 <p>K: JCBB SCREW M6 x 50MM x3</p>
 <p>L: JCBB SCREW M6 x 40MM x12</p>	 <p>M: SPRING WASHER 1/4 " x15</p>	 <p>N: FLAT WASHER 1/4 " x12</p>
 <p>O: PAN HEAD SCREW M4 x 25mm x6</p>	 <p>P: ADJUSTER BASE GLIDE C99 x3</p>	 <p>Q: M4 ALLEN KEY (LONG) x1</p>

STEP 1

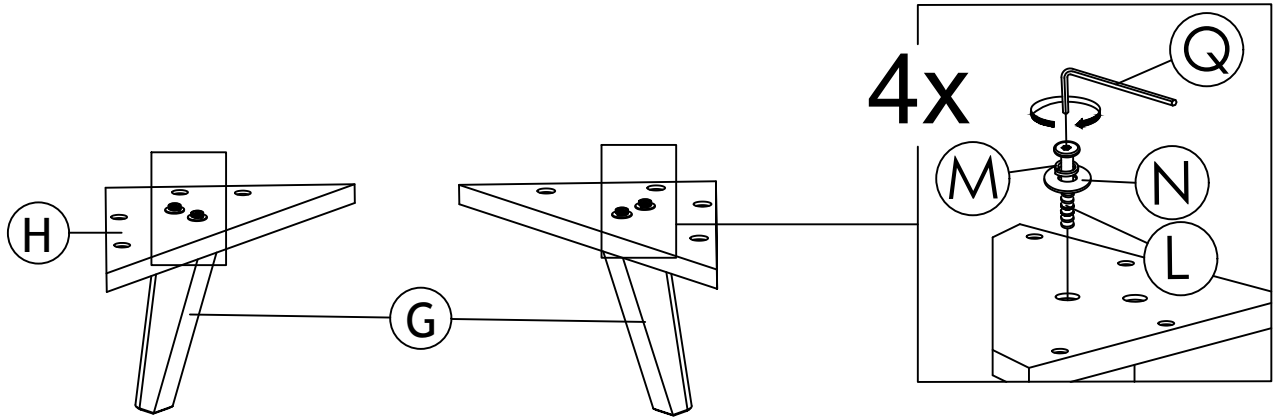

STEP 2

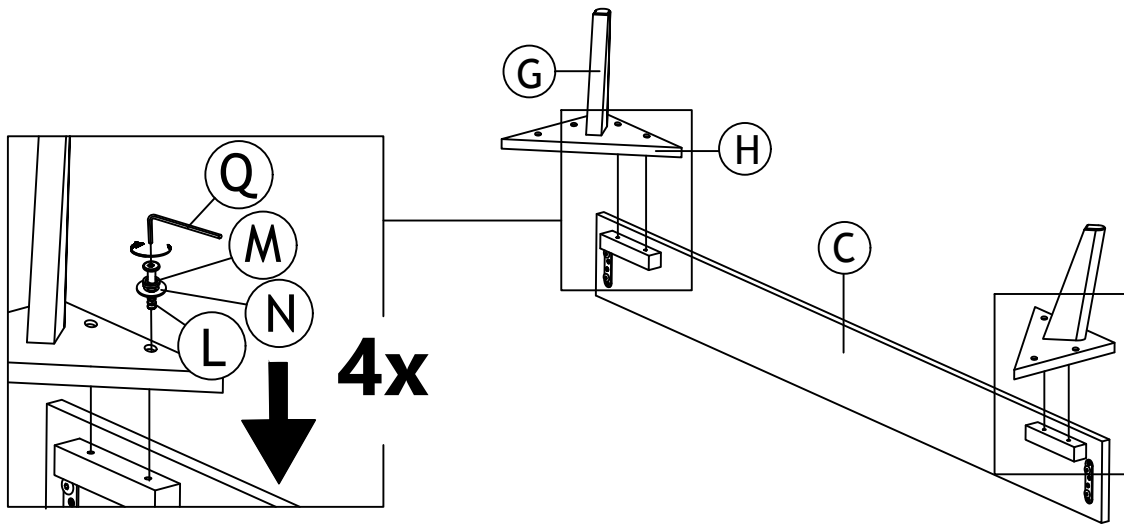

STEP 3

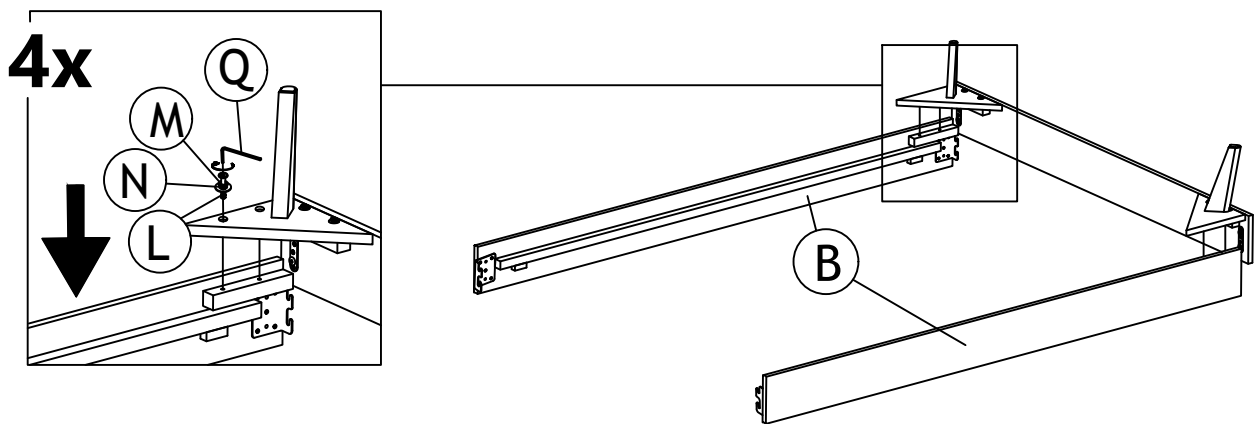

STEP 4

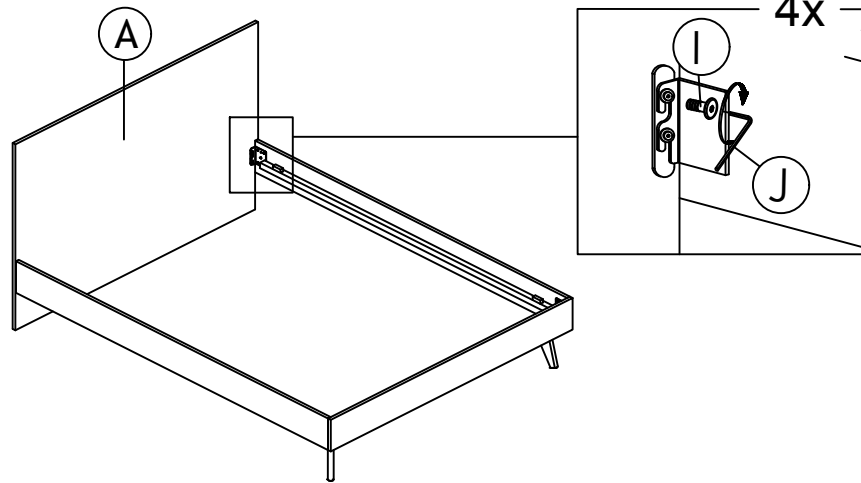

STEP 5

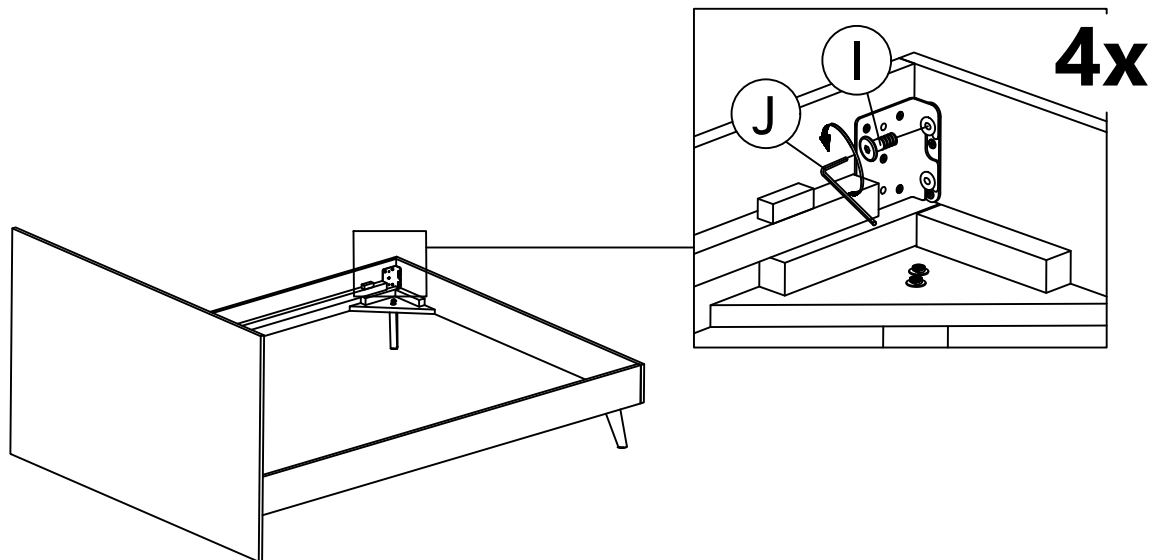

STEP 6

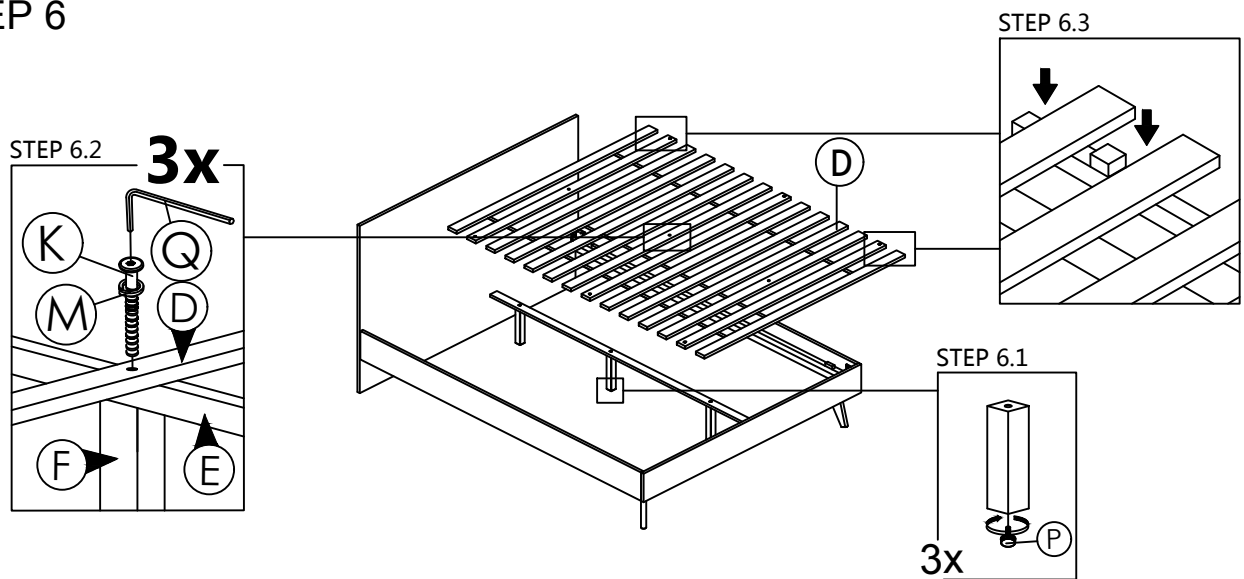

STEP 7

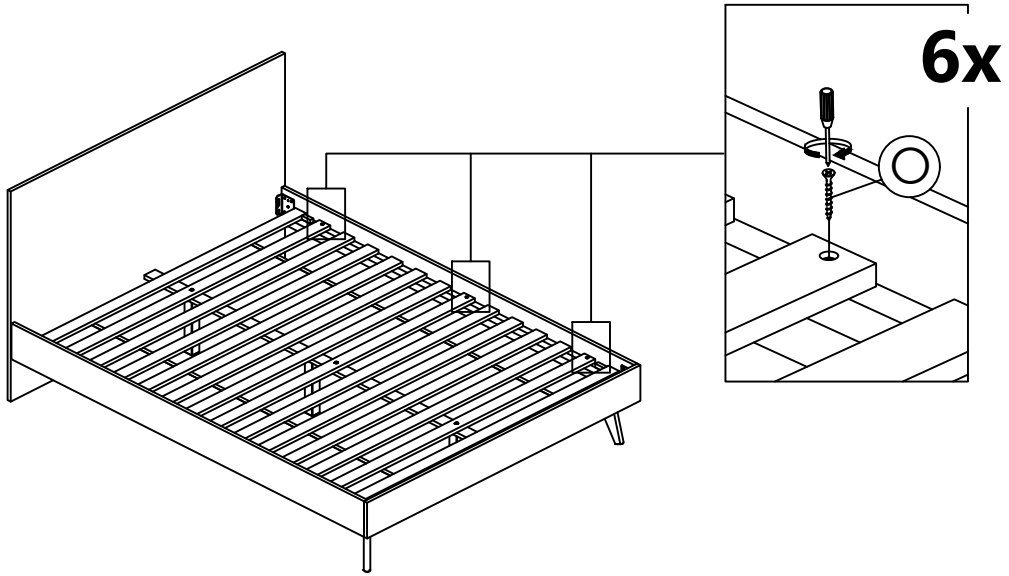

STEP 8

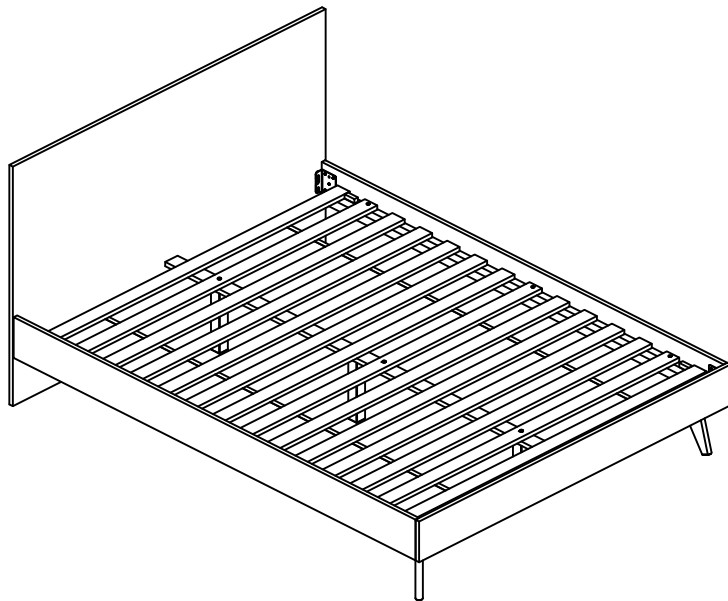

ASSEMBLY COMPLETED

Product Assembly Instructions

PART LIST

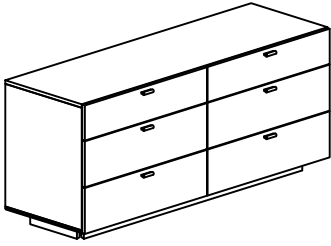

A: DRESSER x1

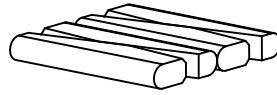

B: LEG x4

HARDWARE LIST



C: JCBC SCREW M6 x 70mm x8



D: SPRING WASHER 1/4" x8



E: FLAT WASHER x8



F: M4 ALLEN KEY (BALL SHAPE) LONG x1



G: WALL SCREW M4 x 18MM x1



H: WALL SCREW M4 x 50MM x1



I: L-BRACKET x2



J: BELT x1

STEP 1

8x

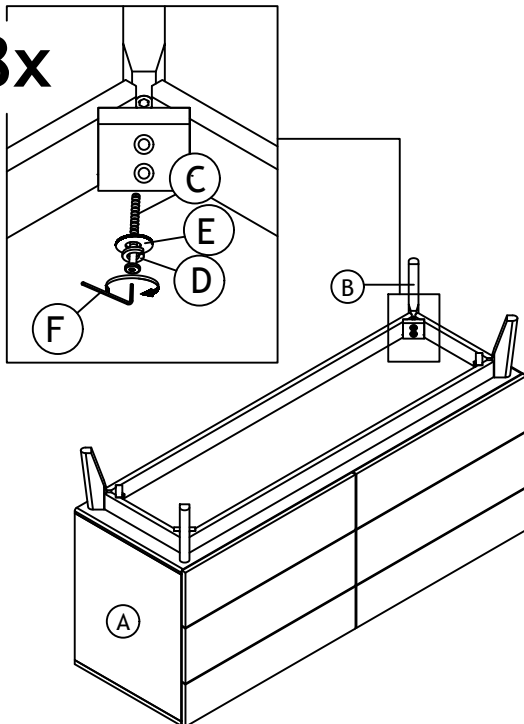

STEP 2

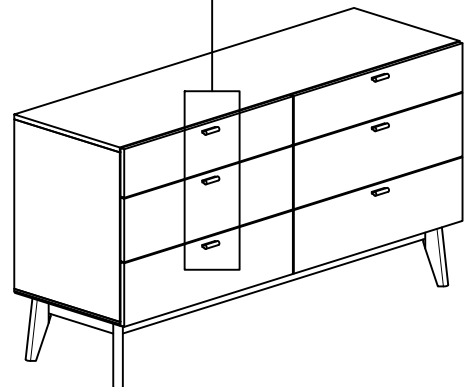
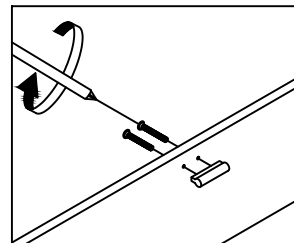

STEP 3

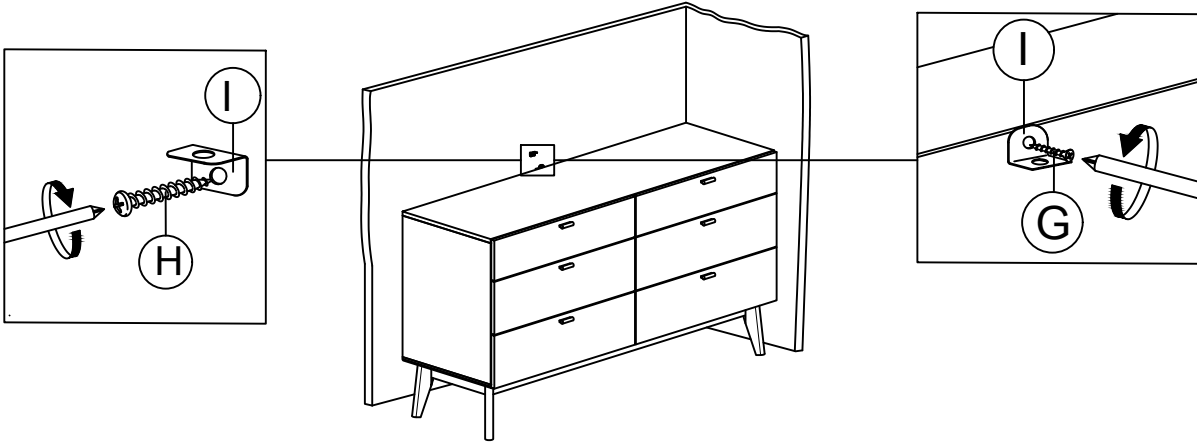

STEP 4

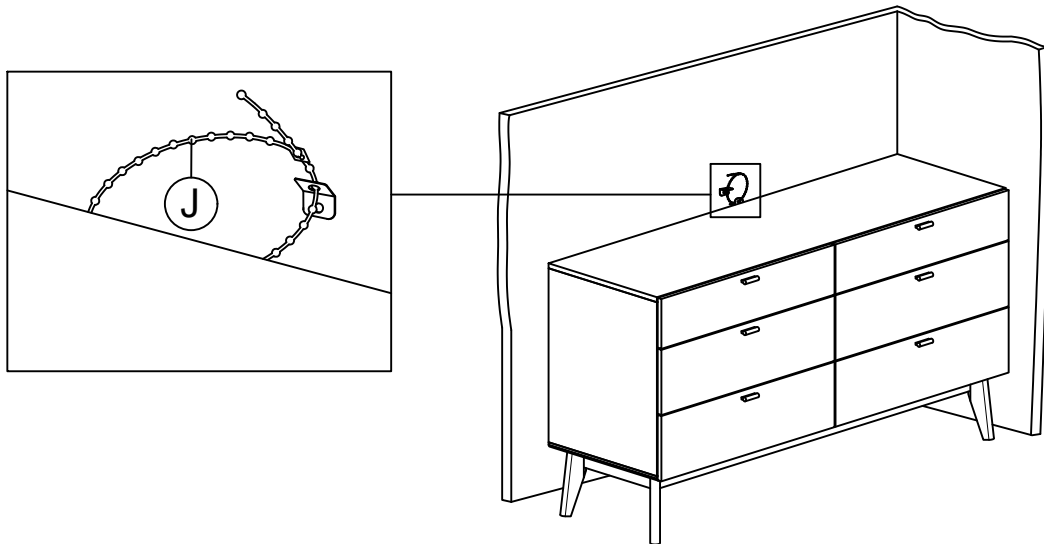

STEP 5

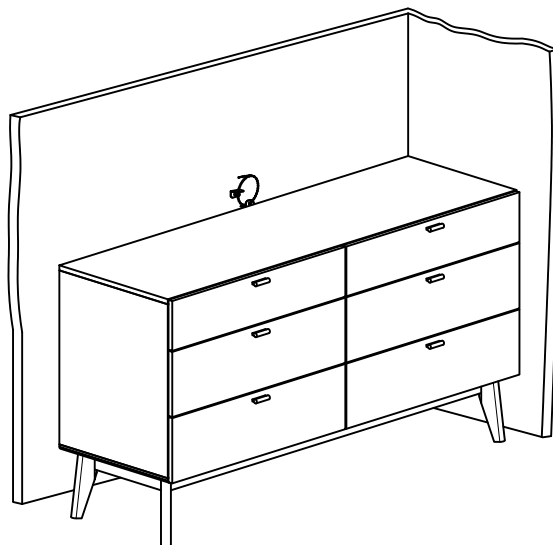

ASSEMBLY COMPLETED