

WF530911AA STORAGE CABINET ASSEMBLY INSTRUCTIONS (INSTRUCTIONS DE MONTAGE)

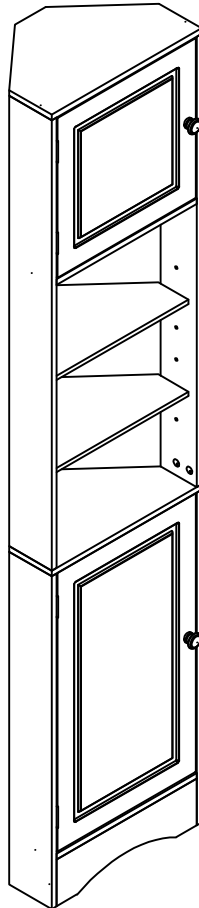

Thank you for purchasing this quality product. Be sure to check all packaging material carefully for small parts which may have come loose inside the carton during shipment. Separate, identify and count all parts and hardware. Compare with the parts list to be sure all parts are present.

"DO NOT TIGHTEN SCREWS UNTIL COMPLETELY ASSEMBLED"

Merci d'avoir acheté ce produit de qualité. Assurez-vous de vérifier soigneusement tout le matériel d'emballage pour détecter les petites pièces qui auraient pu se détacher à l'intérieur du carton pendant le transport. Séparez, identifiez et comptez toutes les pièces et le matériel. Comparez avec la liste des pièces pour vous assurer que toutes les pièces sont présentes.

"NE SERREZ PAS LES VIS AVANT D'ÊTRE COMPLÈTEMENT ASSEMBLÉES"

▲
* Use of power tool to assemble this product will invalidate any claim and damage this product making unsafe !!!
* Please assemble on a clean soft surface to avoid damage.

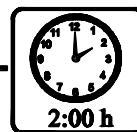
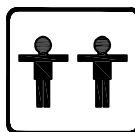

Tools Required

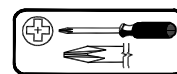

(Not included)

IMPORTANT:

**PLEASE READ INSTRUCTION BEFORE STARTING THE ASSEMBLY
VEUILLEZ LIRE LES INSTRUCTIONS AVANT DE COMMENCER L'ASSEMBLAGE**

Before Installation

Important - Please read these instructions fully before starting assembly

Thank you for purchasing this quality product. Be sure to check all packing materials carefully for small parts, which may have come loose inside the carton during shipment. Identify and count all items according to the PARTS LIST and/or HARDWARE LIST shown below. Check you have all the components and tools listed on the following pages.

- . We recommend that you assemble this product with the assistance of another person; this will make the assembly easier, and will help eliminate damage to the product or injury to persons during assembly.
- . Please do not over tighten screws or bolts until the assembly is completed.
- . Keep children and animal away from the work area, small parts could choke if swallowed.
- . Please put all parts on a non-abrasive floor before assembly, and follow the assembly steps to assemble your newly purchased product correctly and efficiently.

If you find that you have any trouble with assembly or missing or damaged parts please contact the seller.

Cam Lock Assembly Instructions

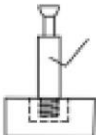
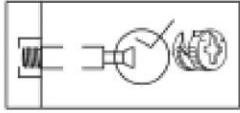
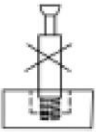
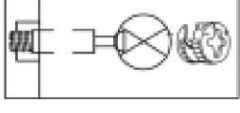
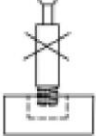
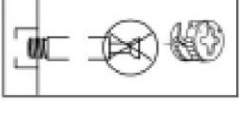
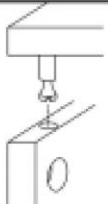
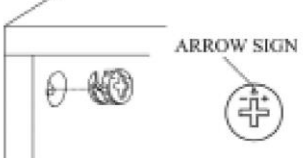
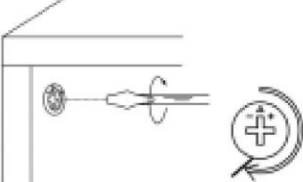
		Diagram A Insert Cam Bolt into hole as shown in diagram A.
		Diagram B Make sure not to insert the Cam Bolt: Too deep as shown in figure B as this will cause the Cam Lock to be misaligned and unable to interlock properly.
		Diagram C Also avoid inserting the Cam Bolt too close to the surface of the hole as shown in figure C, as this will cause the Cam Lock to be too loose, and not interlock properly.
		Connect the panels together.
		ARROW SIGN Insert the Cam Lock so the side opening fits over the head of the Cam Bolt.
		To tighten the Cam Lock, turn it clockwise on half a turn with a flat screwdriver. <i>*Do not use an automatic screwdriver as it may bend or break if too much power is imposed.</i>

Before Installation

Important - Veuillez lire entièrement ces instructions avant de commencer l'assemblage.

Merci d'avoir acheté ce produit de qualité. Assurez-vous de vérifier soigneusement tous les matériaux d'emballage pour détecter les petites pièces qui pourraient s'être détachées à l'intérieur du carton pendant le transport. Identifiez et comptez tous les éléments conformément à la LISTE DES PIÈCES et/ou à la LISTE DU MATÉRIEL indiquée ci-dessous. Vérifiez que vous disposez de tous les composants et outils répertoriés dans les pages suivantes.

- Nous vous recommandons d'assembler ce produit avec l'aide d'une autre personne ; cela facilitera l'assemblage et aidera à éliminer les dommages au produit ou les blessures corporelles pendant l'assemblage.

- Veuillez ne pas trop serrer les vis ou les boulons jusqu'à ce que l'assemblage soit terminé.

- Tenir les enfants et les animaux éloignés de la zone de travail, les petites pièces pourraient s'étouffer en cas d'ingestion.

- Veuillez placer toutes les pièces sur un sol non abrasif avant l'assemblage et suivre les étapes d'assemblage pour assembler correctement et efficacement votre produit nouvellement acheté.

Si vous constatez des problèmes d'assemblage ou des pièces manquantes ou endommagées, veuillez contacter le vendeur.



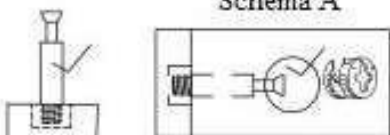
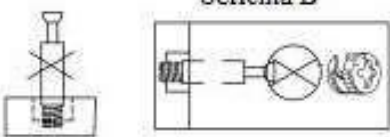
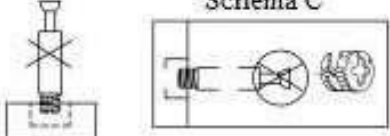
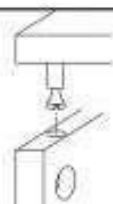
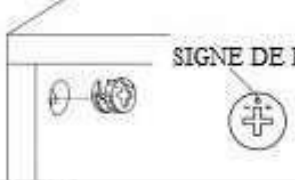
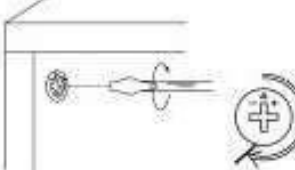

Instructions d'assemblage du verrou à came

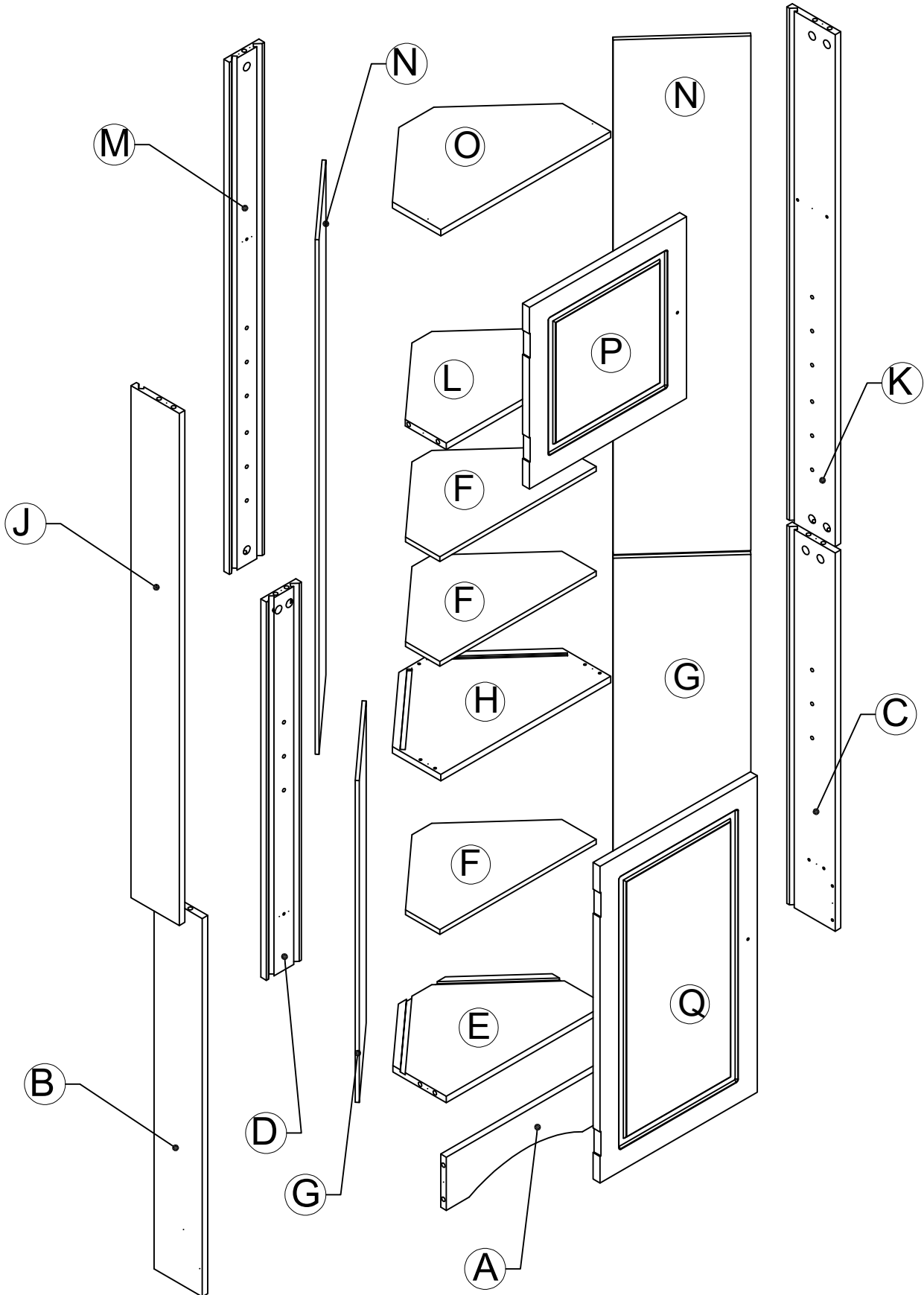
	<p>Schéma A</p> <p>Insérez le boulon à came dans le trou comme indiqué sur le schéma A.</p>
	<p>Schéma B</p> <p>Assurez-vous de ne pas insérer le boulon à came : Trop profond, comme indiqué sur la figure B, car cela entraînerait un mauvais alignement du Cam Lock et son incapacité à se verrouiller correctement.</p>
	<p>Schéma C</p> <p>Évitez également d'insérer le boulon à came trop près de la surface du trou, comme indiqué sur la figure C, car cela rendrait le verrou à came trop lâche et ne s'emboîterait pas correctement.</p>
	<p>Connectez les panneaux ensemble.</p>
	<p>SIGNE DE FLÈCHE</p> <p>Insérez le verrou à came de manière à ce que l'ouverture latérale s'ajuste sur la tête du boulon à came.</p>
	<p>Pour serrer le Cam Lock, tournez-le d'un demi-tour dans le sens des aiguilles d'une montre à l'aide d'un tournevis plat.</p> <p>*N'utilisez pas de tournevis automatique car il pourrait se plier ou se casser si trop de puissance</p>

Detail View - WF530911AA
(Vue détaillée - Vanité)

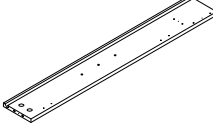
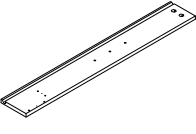
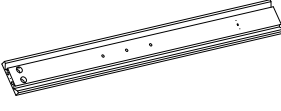
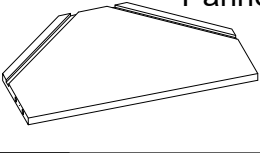
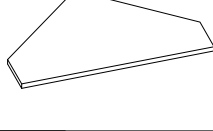

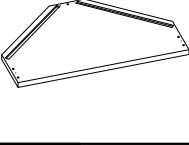
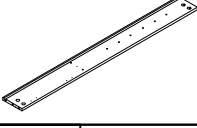
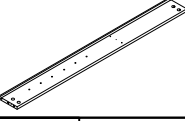
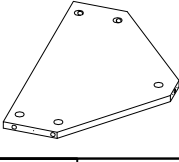
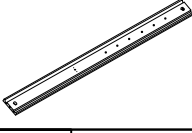
Part List (Liste des pièces) WF530911AA

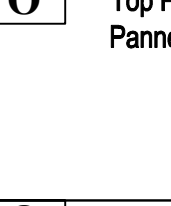
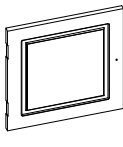
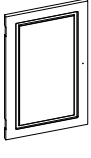
<p>A Front Rail Rail avant</p>  <p>1 PC</p>	<p>B Side Panel (L) Panneau latéral</p>  <p>1 PC</p>
<p>C Side Panel (R) Panneau latéral</p>  <p>1 PC</p>	<p>D Back Panel Panneau arrière</p>  <p>1 PC</p>
<p>E Bottom Panel Panneau inférieur</p>  <p>1 PC</p>	<p>F Adjustable Shelf Étagère réglable</p>  <p>3 PCS</p>
<p>G Side Panel (B) Panneau latéral</p>  <p>02-PCS</p>	<p>H Fixed Shelf Tablette fixe</p>  <p>1 PC</p>
<p>J Side Panel (R) Panneau latéral</p>  <p>1 PC</p>	<p>K Side Panel (R) Panneau latéral</p>  <p>1 PC</p>
<p>L Fixed Shelf Tablette fixe</p>  <p>1 PC</p>	<p>M Back Panel Panneau arrière</p>  <p>1 PC</p>
<p>N Side Panel (T) Panneau latéral</p>  <p>02-PCS</p>	<p>O Top Panel Panneau supérieur</p>  <p>1-PC</p>
<p>P Door (L) Porte</p>  <p>1 PC</p>	<p>Q Door (L) Porte</p>  <p>1 PC</p>

Part List (Liste des pièces) WF530911AA

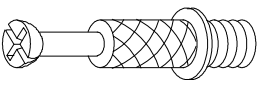
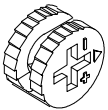
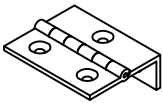
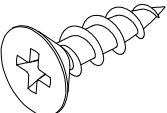
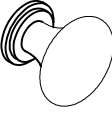
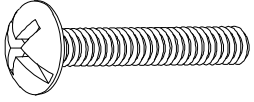
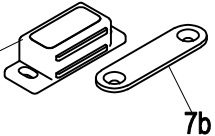
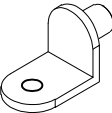
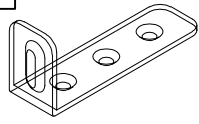
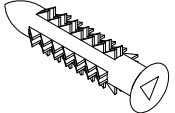
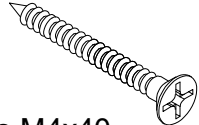
<p>1</p>  <p>Cam Lock Screws Vis de verrouillage à came</p> <p>30 PCS</p>	<p>2</p>  <p>Cam Lock Serrure à came</p> <p>30 PCS</p>	<p>3</p>  <p>Hinges Charnières</p> <p>4 PCS</p>
<p>4</p>  <p>Screws M3.5x12</p> <p>37+3 PCS</p>	<p>5</p>  <p>Handle Poignée</p> <p>2 PCS</p>	<p>6</p>  <p>Screws M4x20 boulons à tête de vis</p> <p>2 PCS</p>
<p>7</p>  <p>7a 7b</p> <p>Magnet Aimant</p> <p>2 PCS</p>	<p>8</p>  <p>Shelf Support Support d'étagère</p> <p>9 PCS</p>	<p>9</p>  <p>Brackets</p> <p>2-PCS</p>
<p>10</p>  <p>Plastic Stopper</p> <p>2-PCS</p>	<p>11</p>  <p>Screws M4x40</p> <p>02-PCS</p>	

ASSEMBLY TOOLS REQUIRED (NOT INCLUDED)

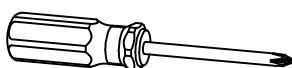

STEP : 1 (ÉTAPE : 1)

1
9 PCS

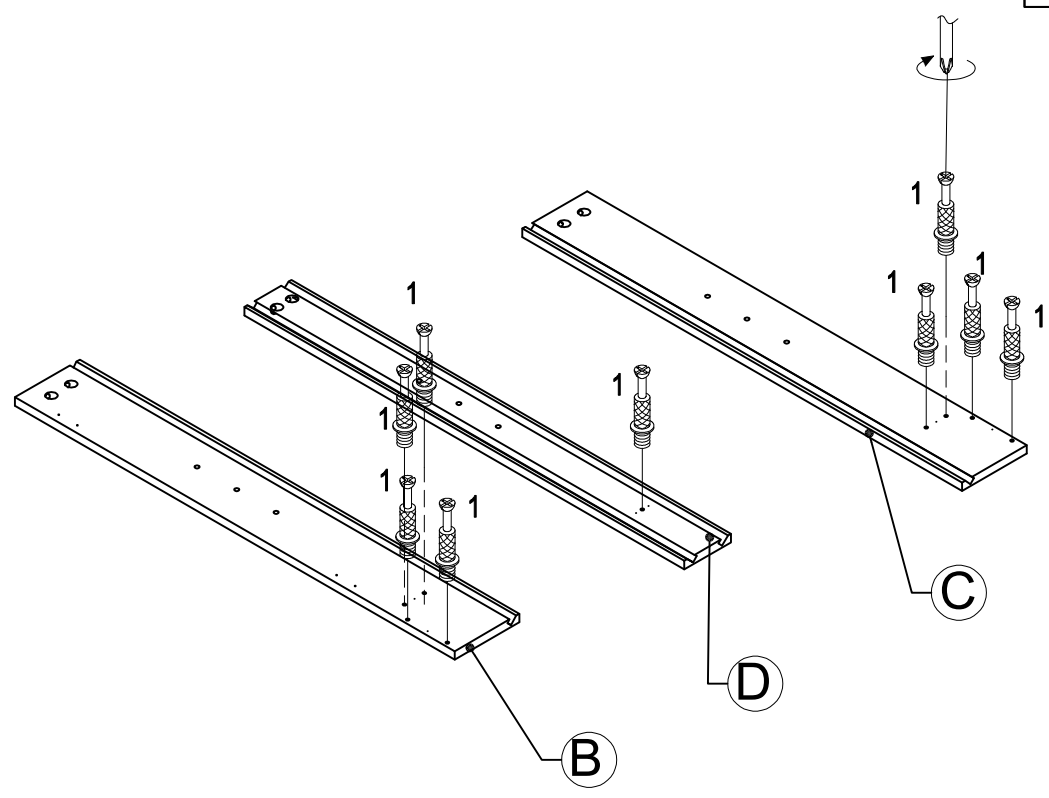

STEP : 2 (ÉTAPE : 2)

2
4 PCS

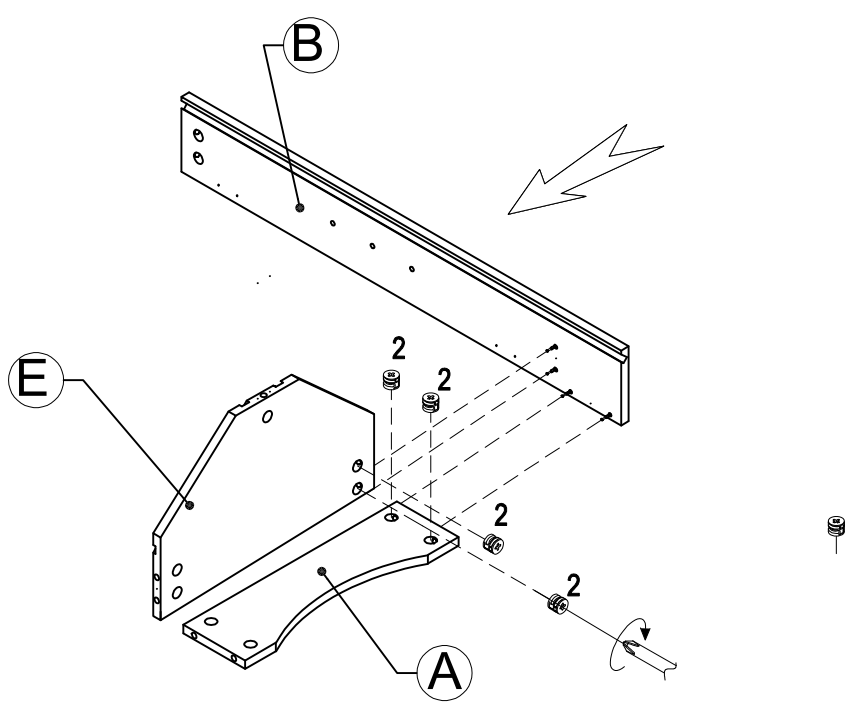

STEP : 3 (ÉTAPE : 3)

2



4 PCS

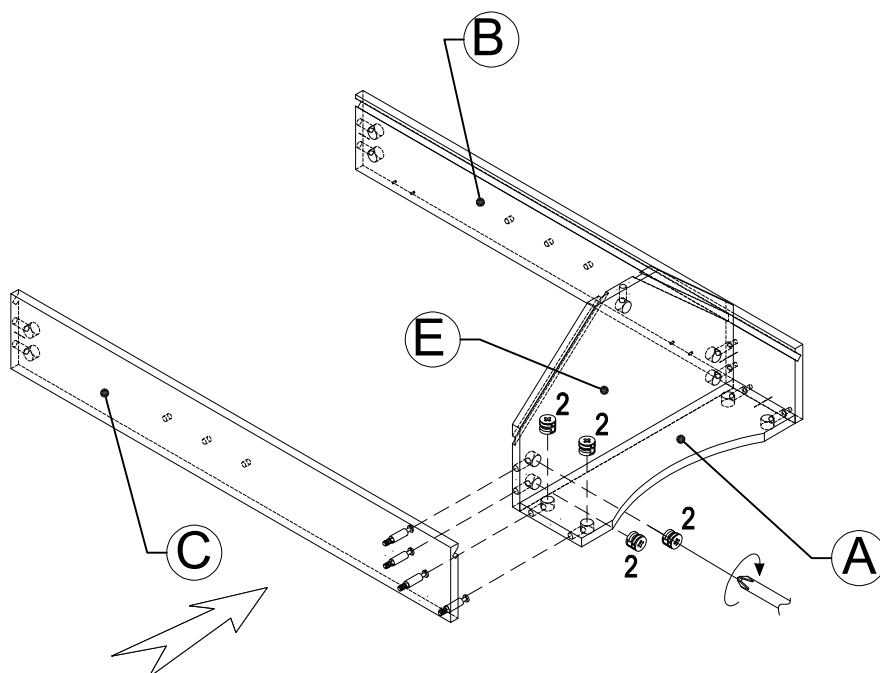

STEP : 4 (ÉTAPE : 4)

2



1 PC

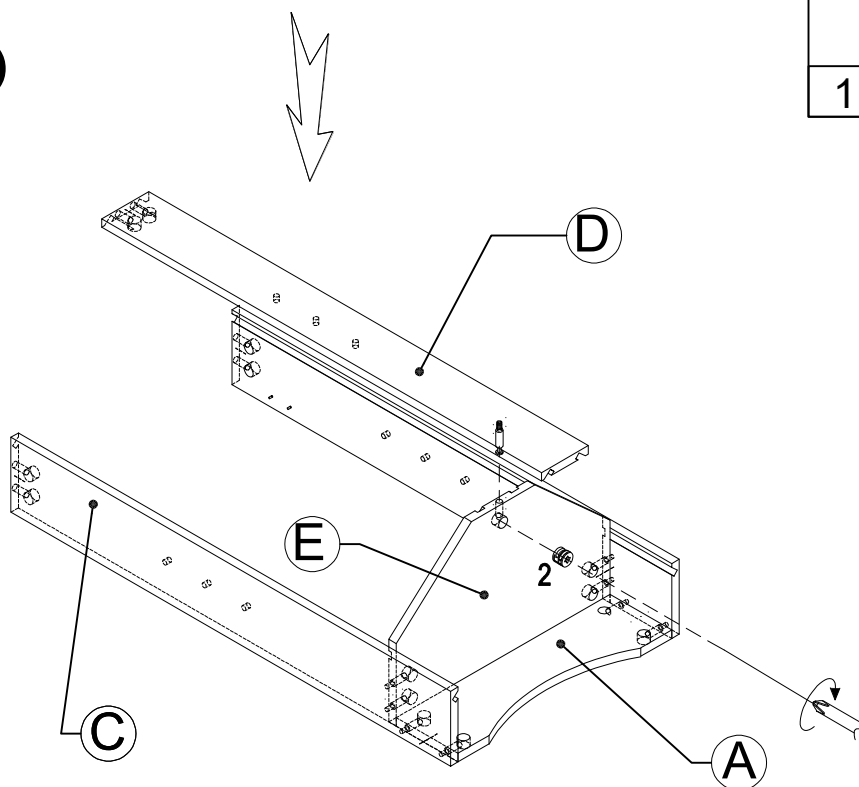

STEP : 5 (ÉTAPE : 5)

1

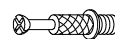

5 PCS

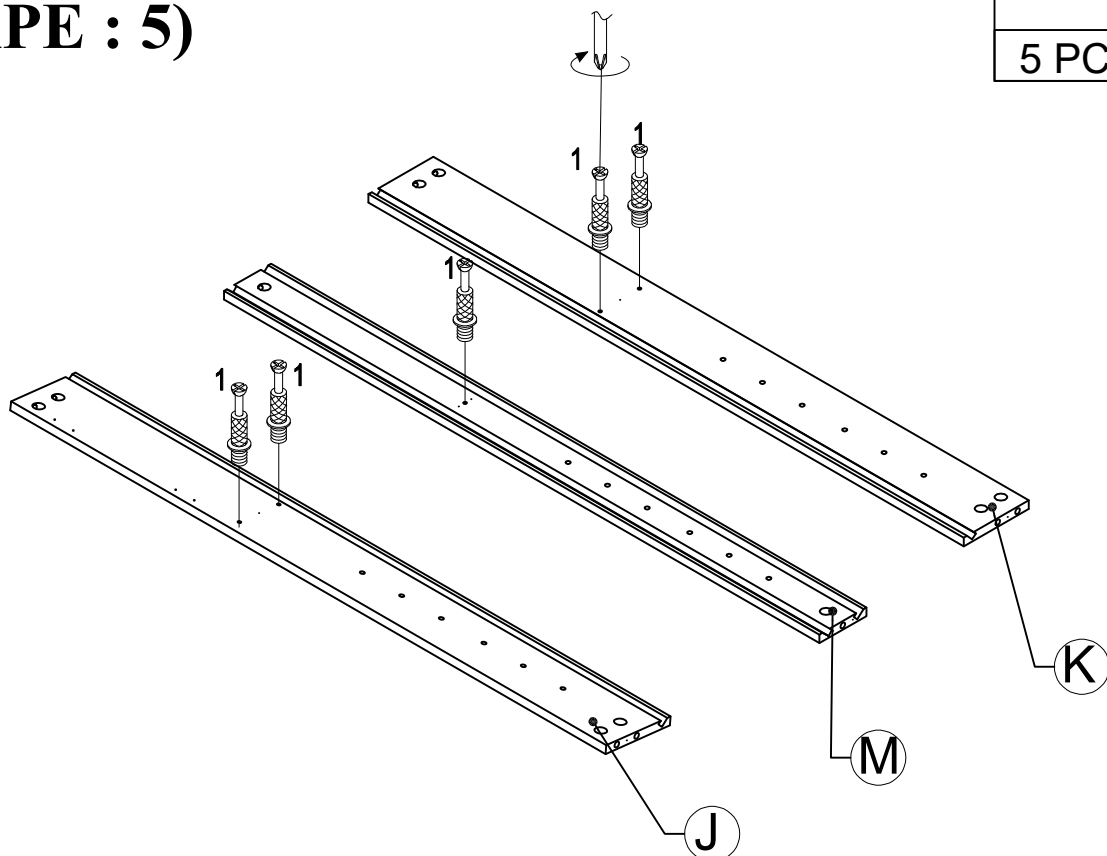

STEP : 6 (ÉTAPE : 6)



2

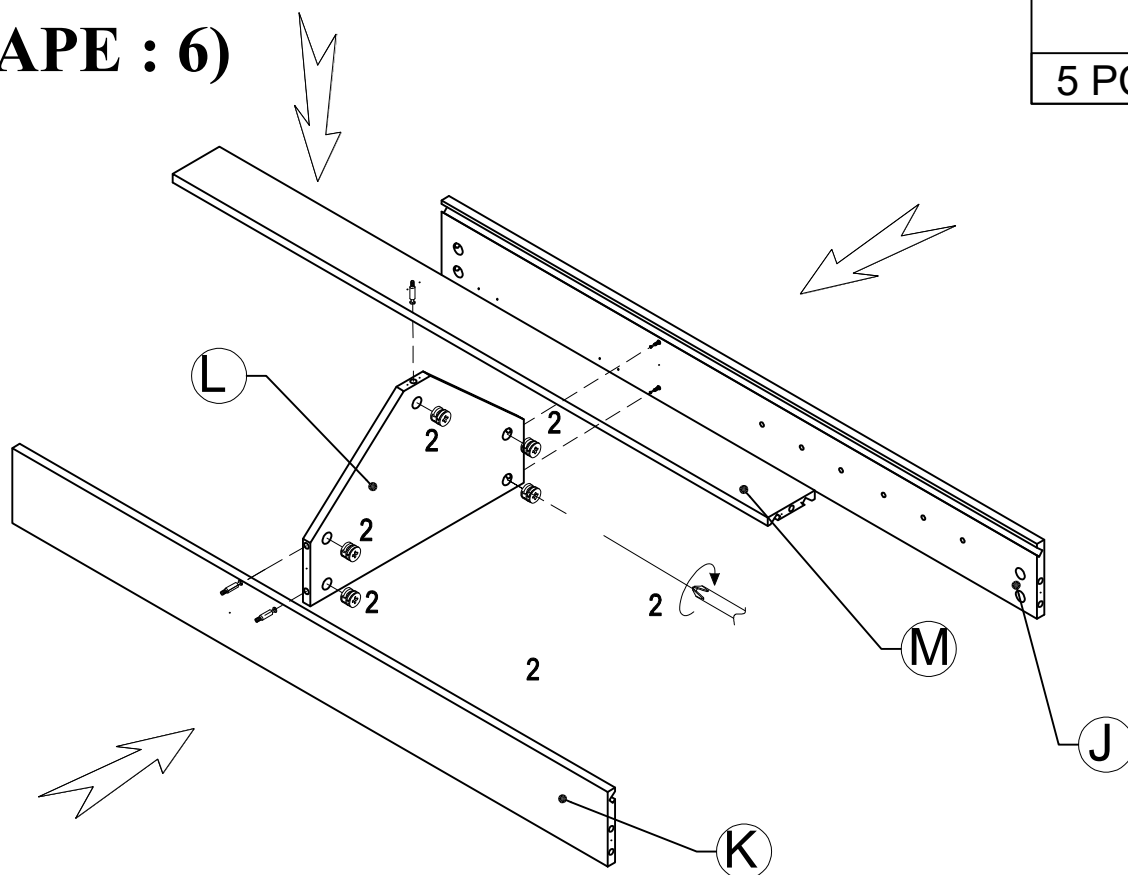

5 PCS

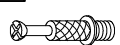

STEP : 7 (ÉTAPE : 7)

4	 M3.5 X12	7a		1	
4 PCS		2 PCS		11 PCS	

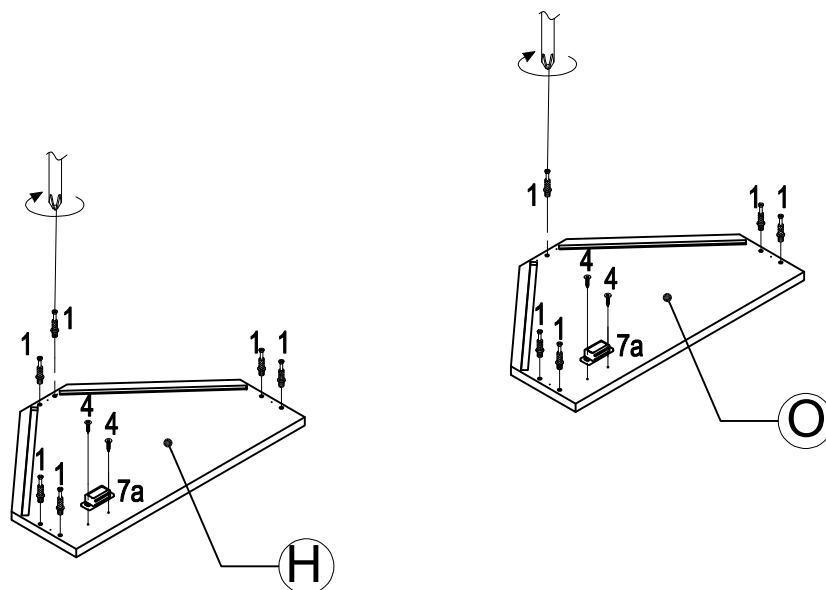

STEP : 8 (ÉTAPE : 8)

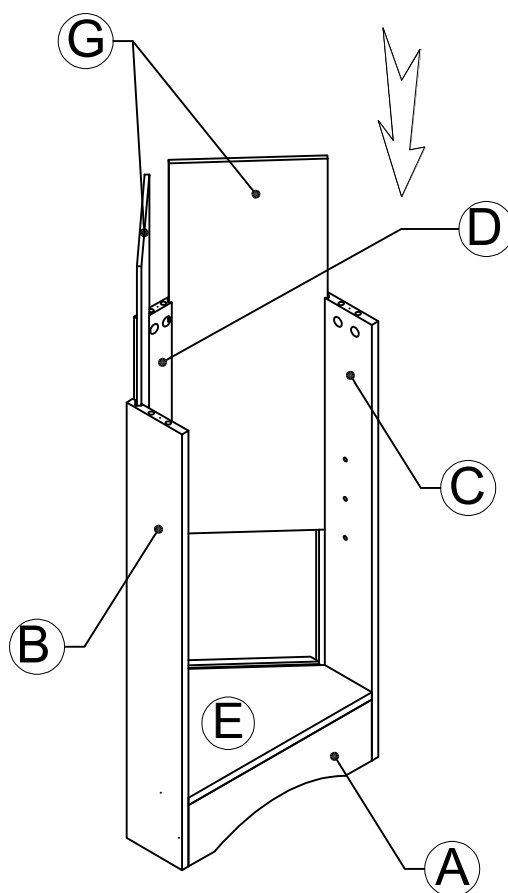

STEP : 9 (ÉTAPE : 9)

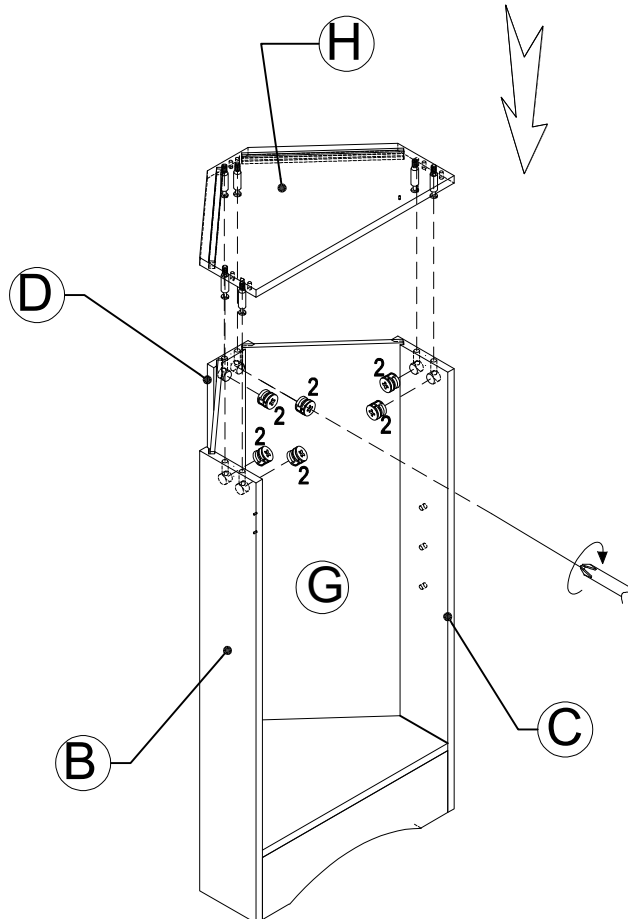

2



06 PCS

STEP : 10 (ÉTAPE : 10)

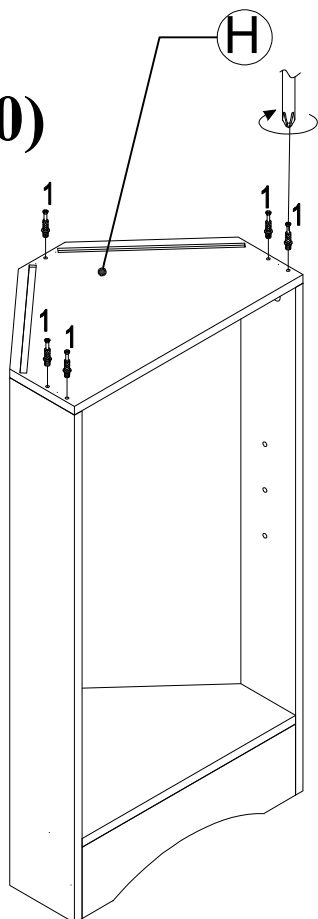

1

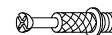

5 PCS

STEP : 11 (ÉTAPE : 11)

2



5 PCS

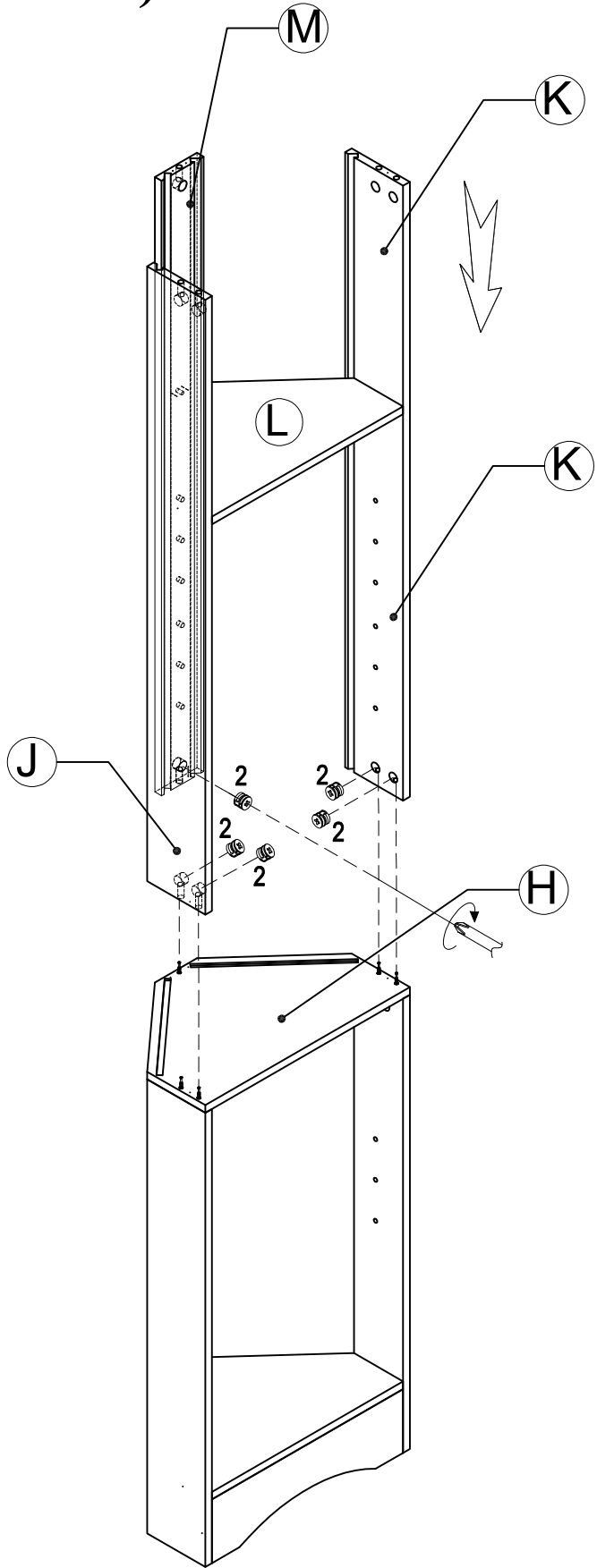

STEP : 12
(ÉTAPE : 12)

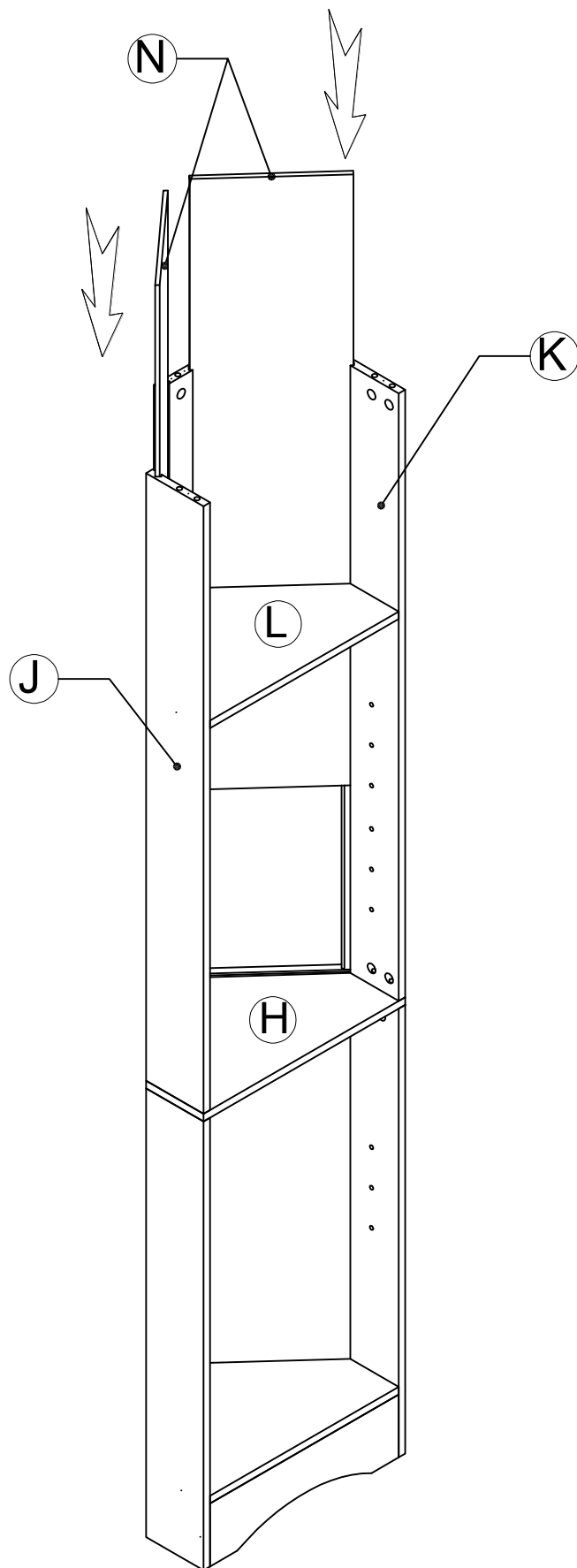

STEP : 13 (ÉTAPE : 13)



2

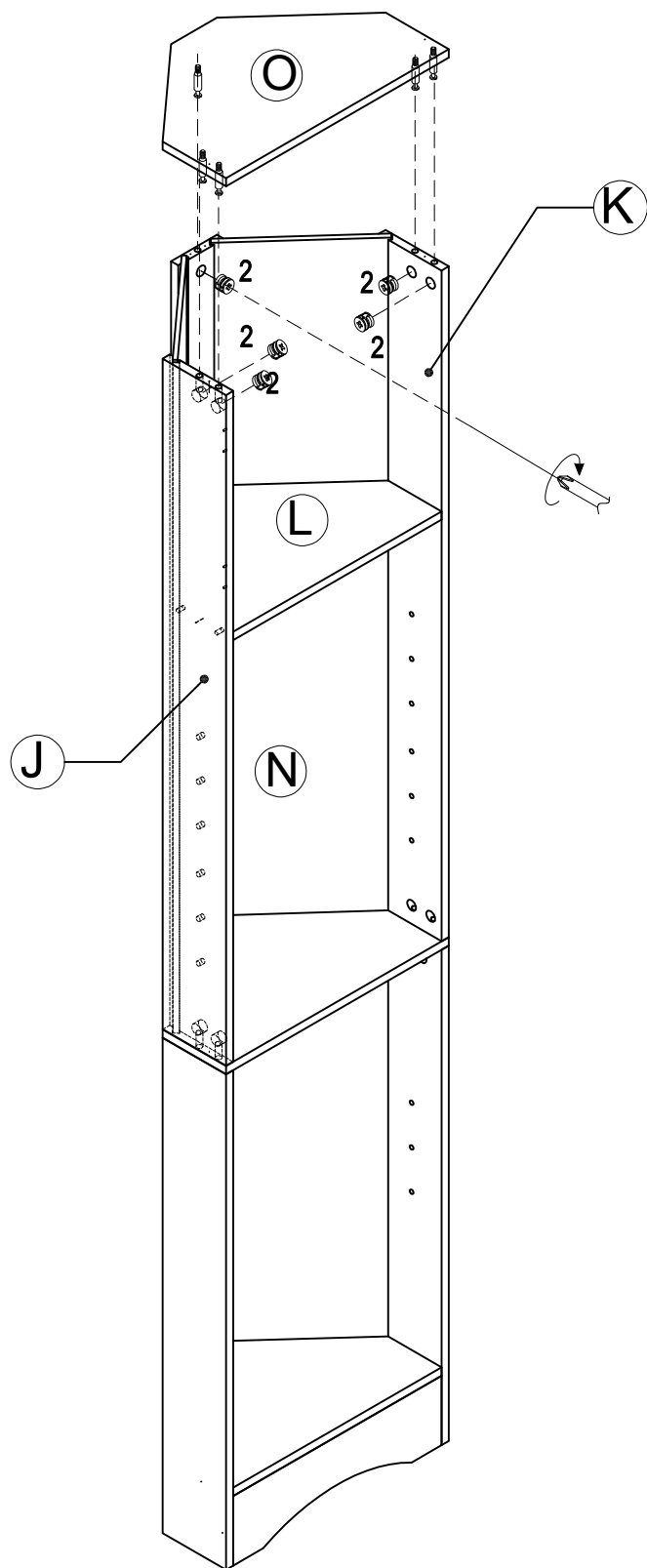

5 PCS





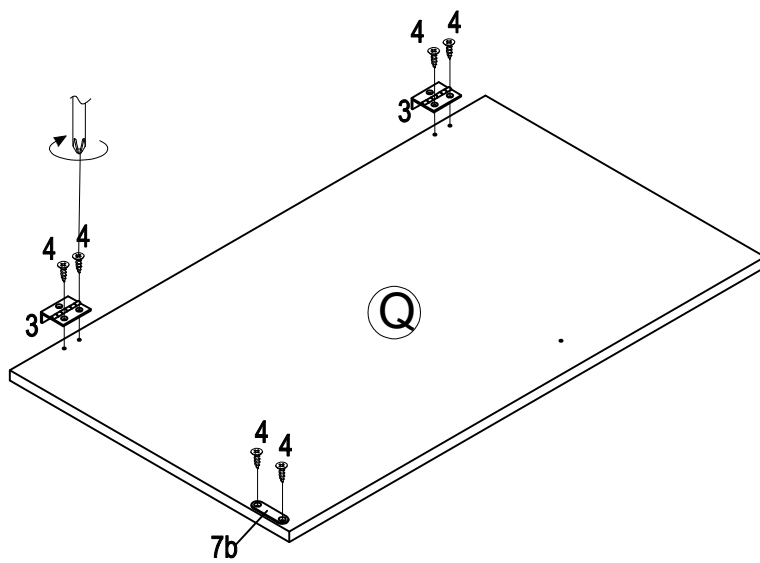
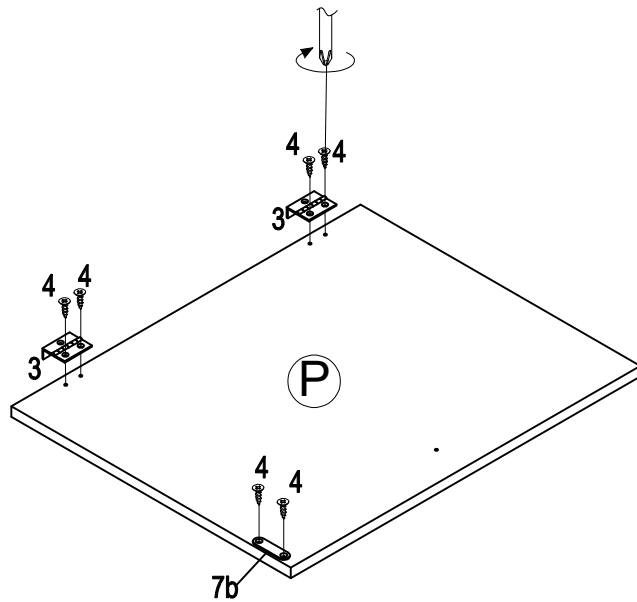

STEP : 14 (ÉTAPE : 14)

7b	3	4
		
2 PCS	04 PCS	M3.5 X12 12 PCS





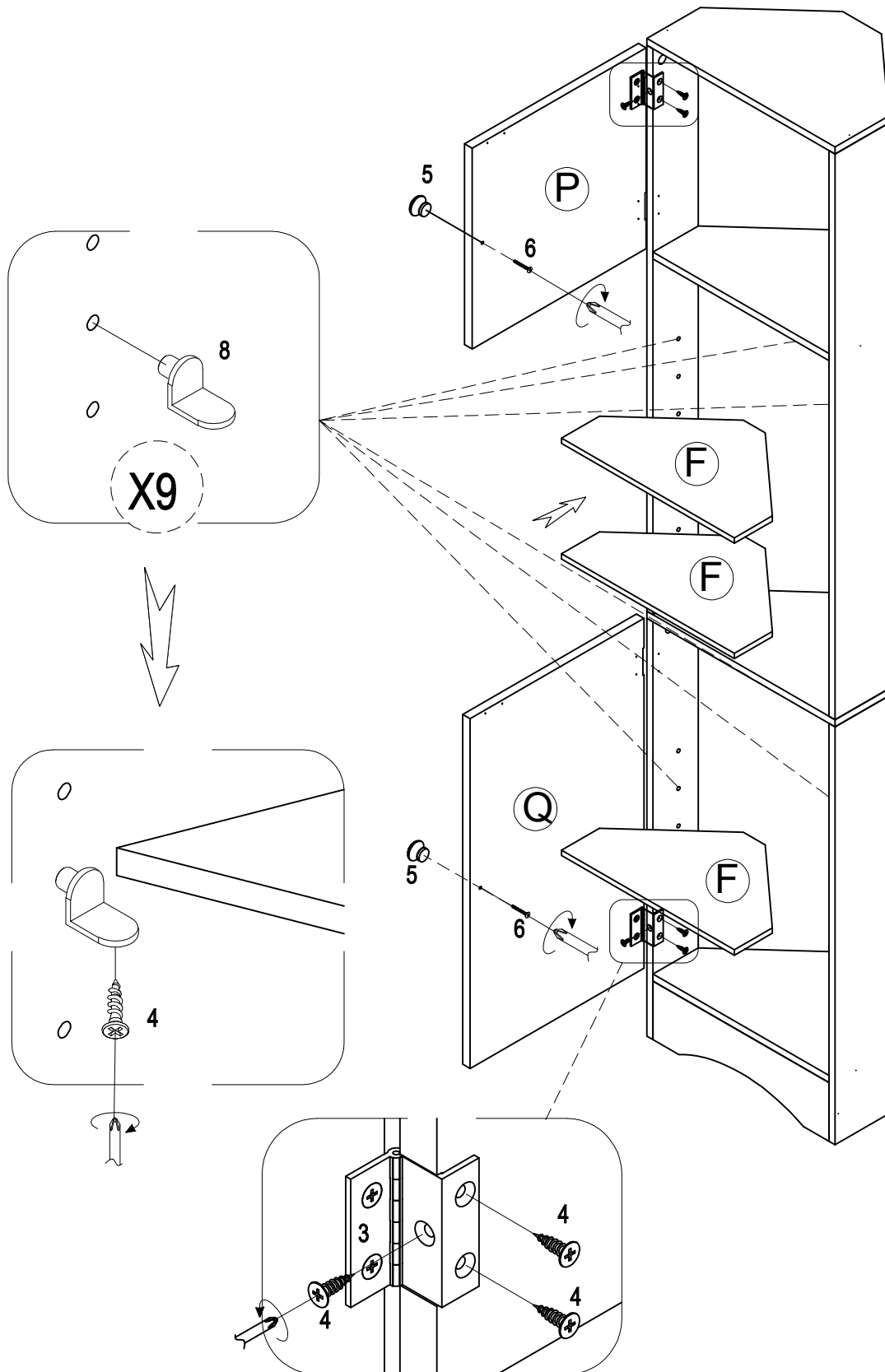

STEP : 15

(ÉTAPE : 15)

5		6		8		4	
			M4 X20				M3.5 X12
2 PCS		2 PCS		9 PCS		15 PCS	



9	10	11	4
			
2-PCS	2-PCS	M4 X40	M3.5 X12
		2-PCS	6 PCS

