

ASSEMBLY INSTRUCTIONS

30" GATHERED BACK BAR STOOL



We are here to help!

MADE IN CHINA





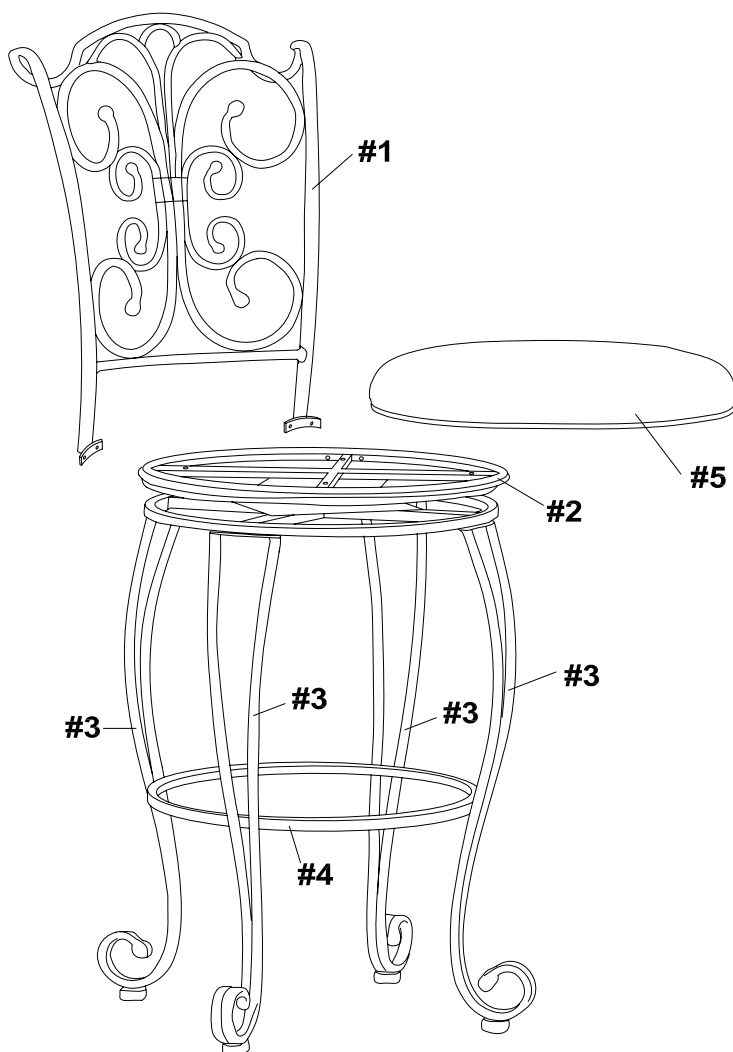

Parts Identification

ITEM	DESCRIPTION	QTY
#1	BACK FRAME	01
#2	SEAT FRAME	01
#3	LEG FRAME	04
#4	BOTTOM SUPPORT RING	01
#5	CUSHION	01

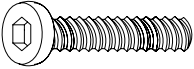
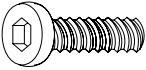

For ease of identification all parts are labeled to correspond to the Step number in which the part is used.

Hardware Identification

ITEM	PICTURE	DESCRIPTION	QTY
A	 (Ø6mmx30mm)	LONG BOLT	04
B	 (Ø6mmx12mm)	SHORT BOLT	12
C	 (Ø5mmx30mm)	WOOD SCREW	04
D	 (Ø1/4")	NUT	04
E	 (Ø1/4")	FLAT WASHER	16
F	 (Ø1/4")	SPRING WASHER	12
G		HEXAGONAL WRENCH	01
H		OPEN SPANNER	01

STEP 1.

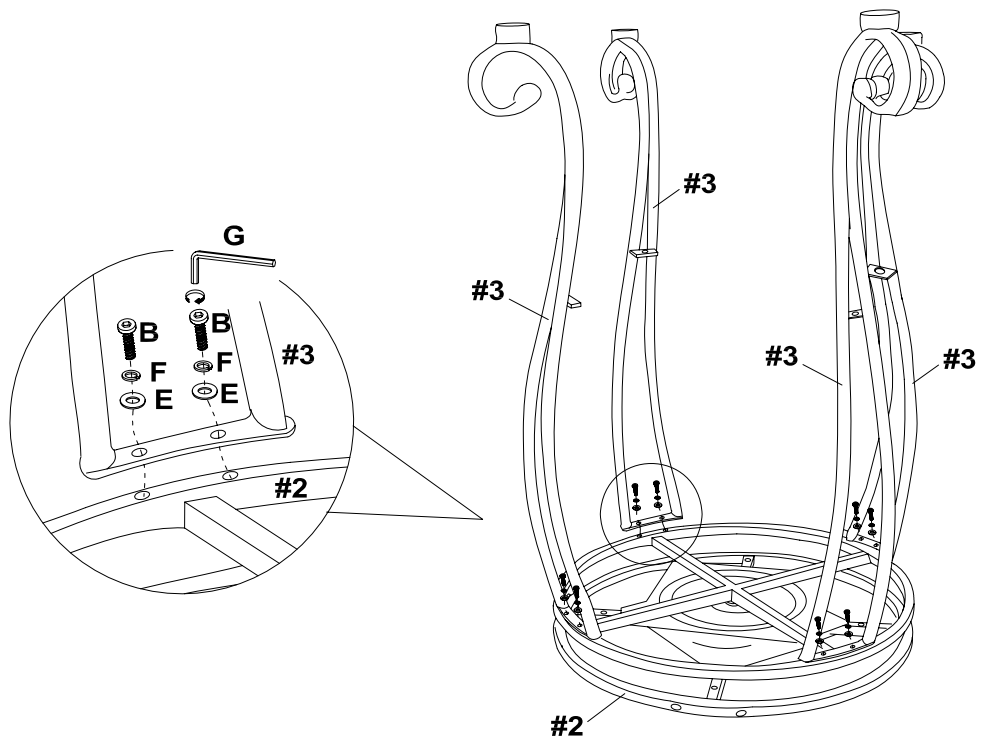

STEP 2.

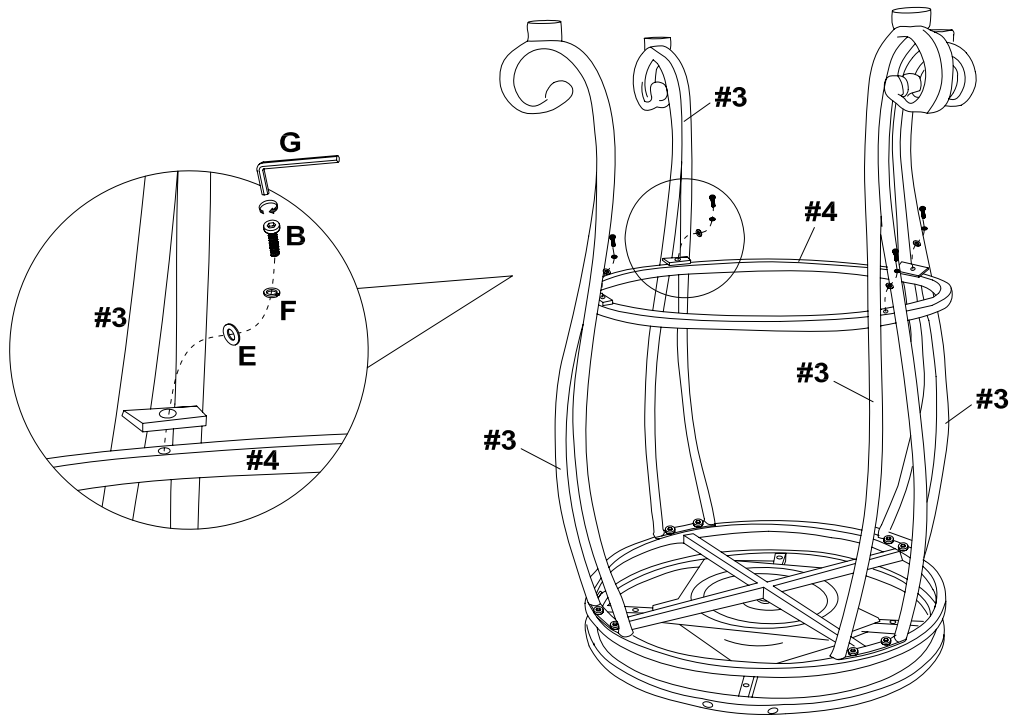

IMPORTANT: DO NOT TIGHTEN COMPLETELY ANY BOLT UNTIL ALL LINED-UP BOLTS ARE CONNECTED TO INSERTED NUTS.

STEP 3.

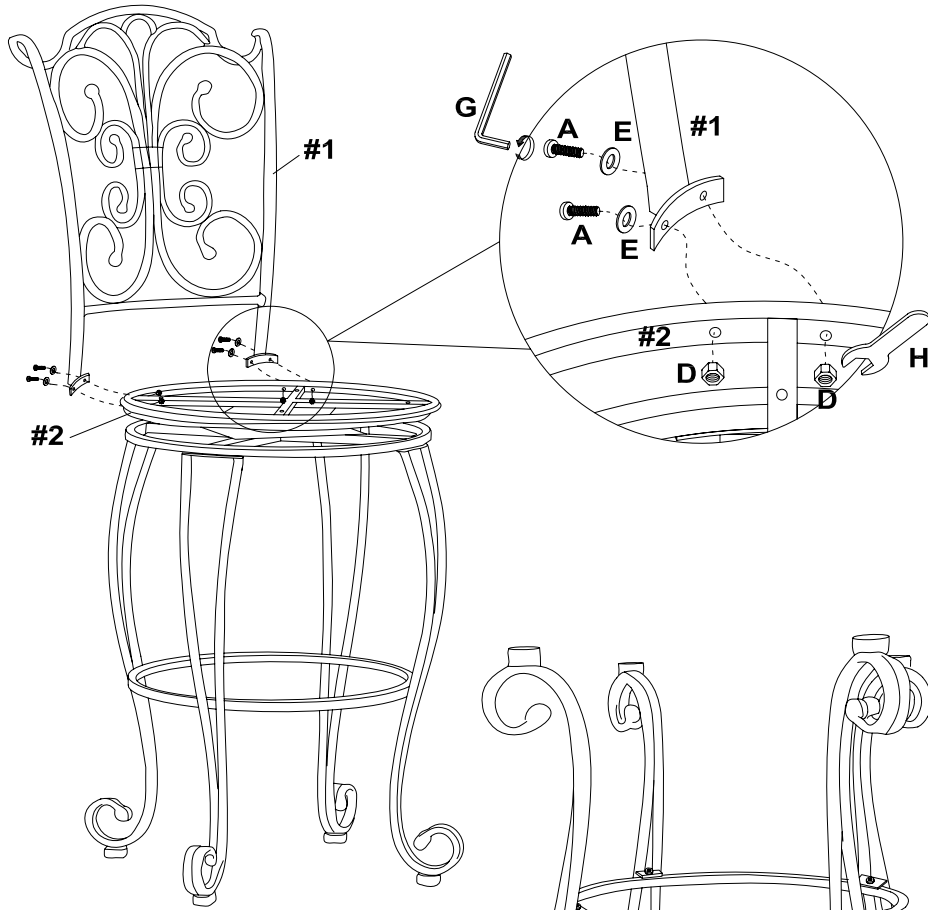

STEP 4.

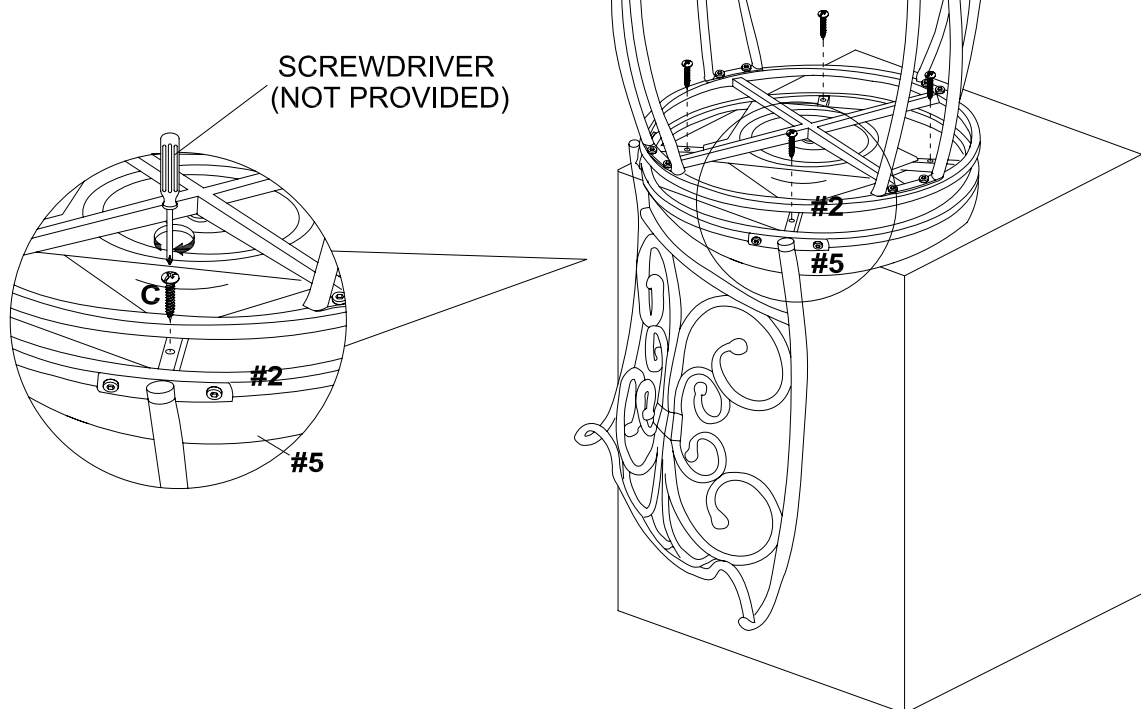

WARRANTY