





















ASSEMBLY INSTRUCTION

KB

NO	PARTLIST	QTY
1	 HEADBOARD CUSHION	1PC
2	 RIGHT HEADBOARD LEG (WITH "R" LABEL)	1PC
3	 LEFT HEADBOARD LEG (WITH "L" LABEL)	1PC
4	 FOOTBOARD CUSHION	1PC
5	 FOOTBOARD LEG	2PCS
6	 SIDE RAIL (LEFT)	2PCS
7	 SIDE RAIL (RIGHT)	2PCS
8	 SIDE RAIL SUPPORT LEG	2PCS
9	 SLAT	4PCS
10	 SUPPORT LEGS WITH ADJUSTABLE FEET	8PCS
NO	HARDWARE LIST	QTY
A	 JCBB SCREW M8 x 20MM	8PCS
B	 JCBC SCREW M6 x 25MM	8PCS
C	 JCBC SCREW M6 x 35MM	14 PCS
D	 JCBC SCREW M6 x 70MM	2PCS
E	 WOOD DOWEL	2PCS
F	 SPRING WASHER	14PCS
G	 FLAT WASHER	14PCS
H	 SCREW M4 x 32MM	8PCS
I	 L - KEY M5 x 65MM	1PC
J	 L - KEY M4 x 65MM	1PC

STEP 1

Begin assembly by attaching each headboard leg (2) & (3) to the bottom of the headboard cushion (1) by aligning the hole and securing with 3 Allen Bolts (C), 3 spring washer (F), 3 flat washer (G) per leg using L-key (J). (DO NOT FULLY TIGHTEN BOLTS FOR THIS STEP)

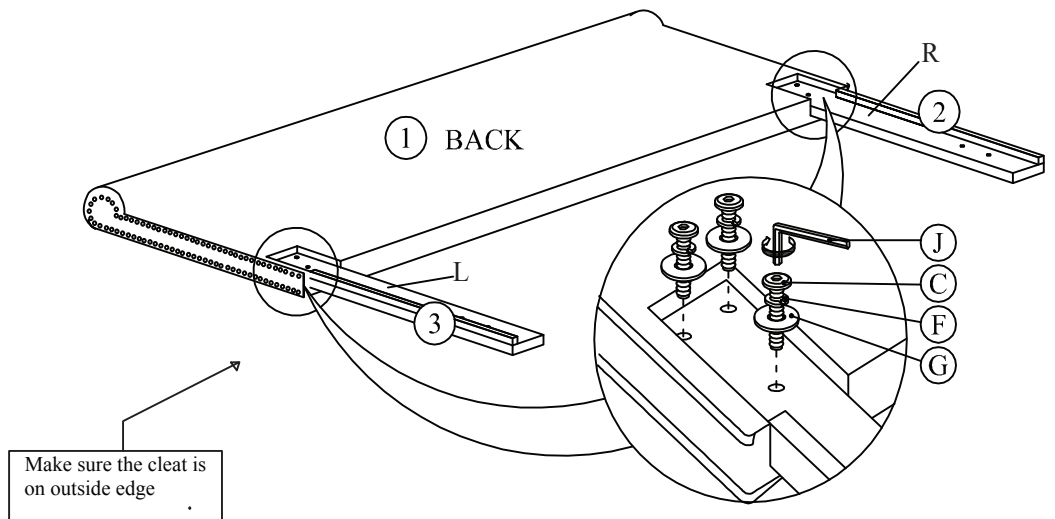

STEP 2

Attach each footboard legs (5) to the bottom of the footboard cushion (4) by inserting a dowel (E) & securing with 1 Allen Bolt (D) per leg using L-key (J).

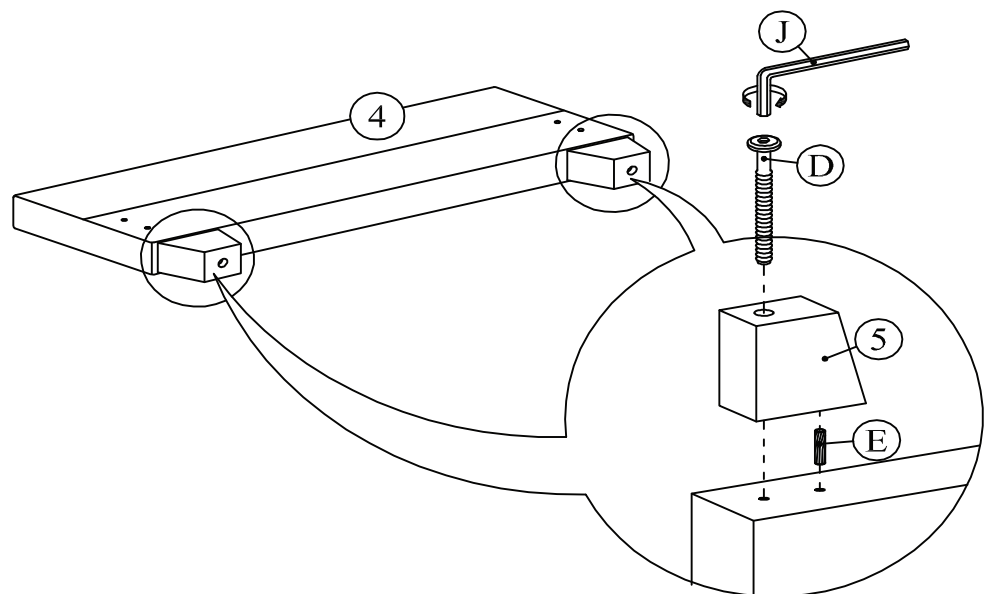

Do not fully tighten screws until assembly is complete and the bed is level

NOTE : AFTER A FEW DAYS , IT WILL HAVE ACCLIMATIZED TO THE ENVIRONMENT. PLEASE TIGHTEN ALL HARDWARE. CHECK TIGHTNESS OD ALL SCREWS EVERY 6-8 WEEKS.

ASSEMBLY INSTRUCTION

STEP 3

Attach side rail support leg (8) to the join of the side rail (6) and side rail (7) by securing with 4 Allen Bolts (B) , 4 spring washer (F) , 4 flat washer (G) per support using L-key (J).

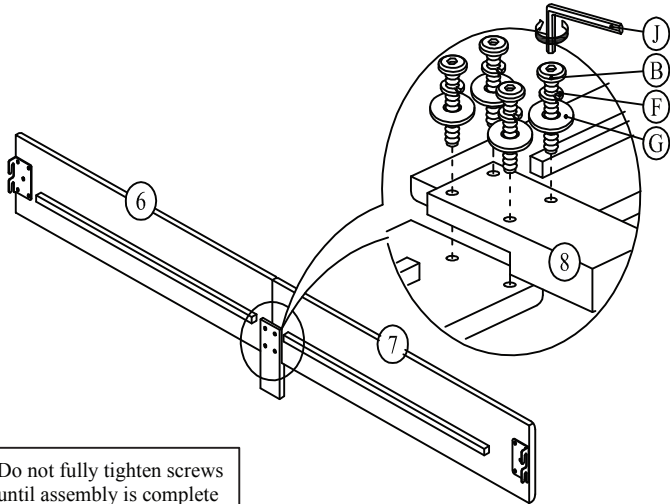

Do not fully tighten screws until assembly is complete and the bed is level

STEP 4

Attach side rail to the headboard leg (2) & (3) and footboard (4). Aligning holes and securing with 2 Allen Bolts (A) per each and using L-key (I).
(DO NOT FULLY TIGHTEN BOLTS FOR THIS STEP)

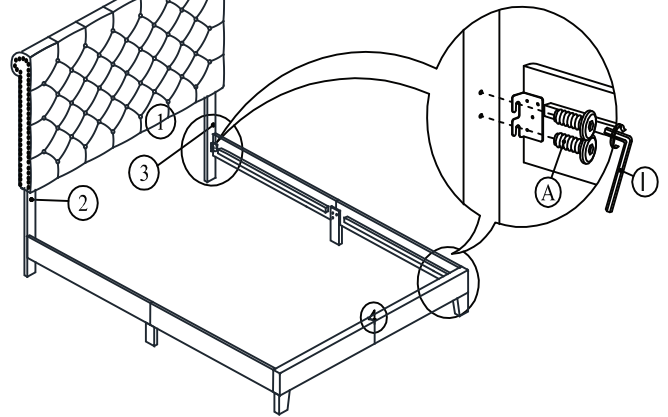

STEP 5

Attach support legs (10) to slat (9) by securing with 1 Allen Bolt (C) per support (2 support legs per slat as shown). Attach slat (9) to side rail by securing with 1 screws (H) per each side. Tighten all screws using philips head screw driver (not included). Tighten all bolts on step 2 & 3 using the L-key (J) following step 4 using the L-key (I) that has been provided.

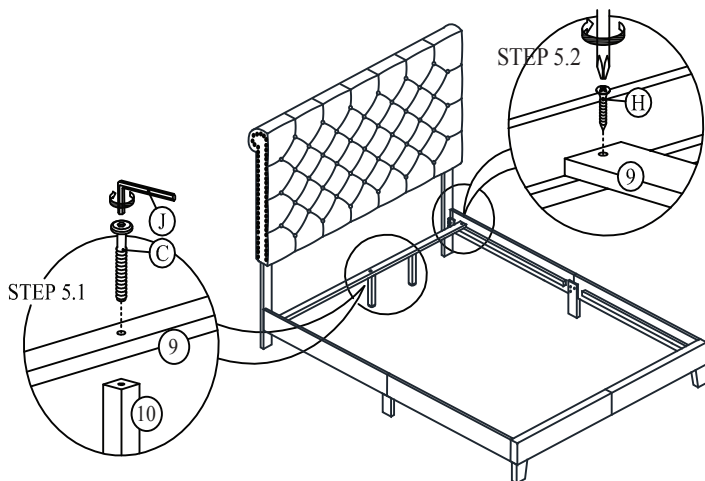

STEP 6

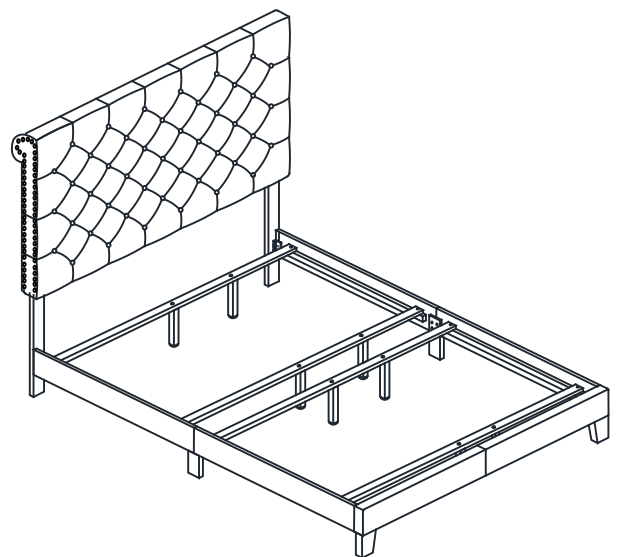

ASSEMBLY
COMPLETED

NOTE : AFTER A FEW DAYS , IT WILL HAVE ACCLIMATIZED TO THE ENVIRONMENT.
PLEASE TIGHTEN ALL HARDWARE. CHECK TIGHTNESS OF ALL SCREWS EVERY 6-8 WEEKS.