

# ASSEMBLY INSTRUCTIONS

## INSTRUCTIONS DEMONTAGE

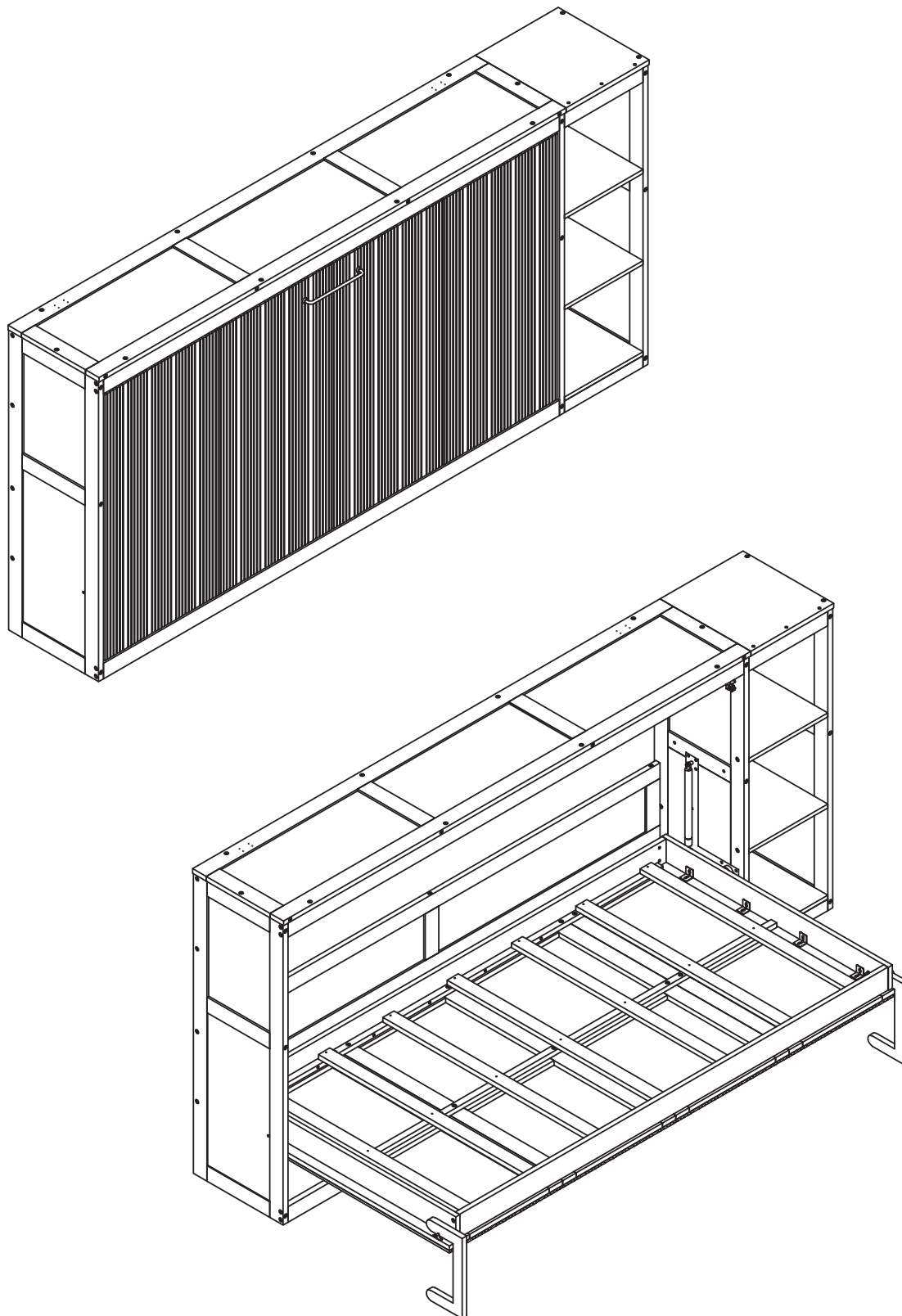

# DETAIL VIEW VUE DÉTAILLÉE

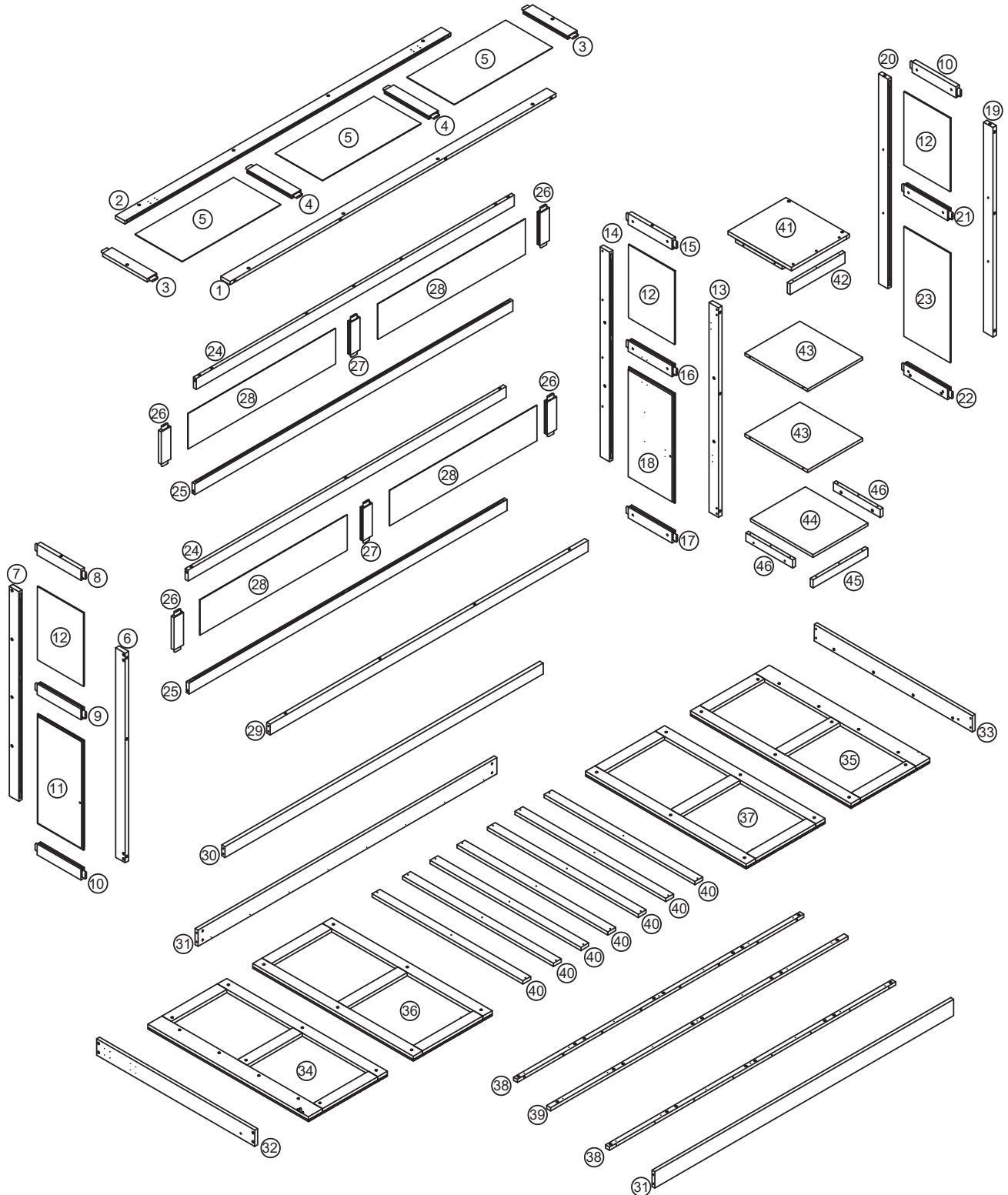

# Part Lists (Box 1)

## Liste des pièces

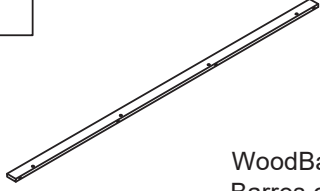
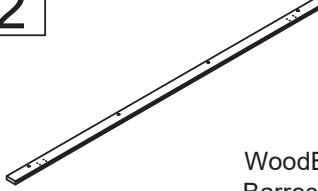
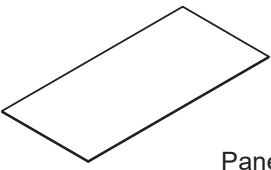
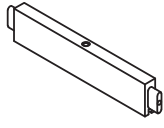
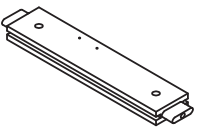
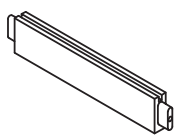
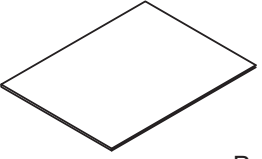
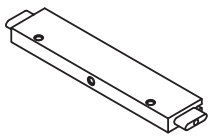
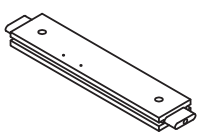
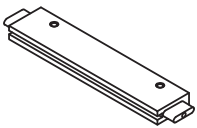
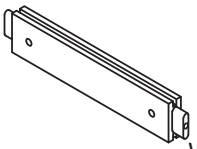
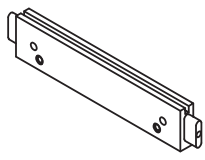
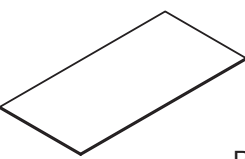
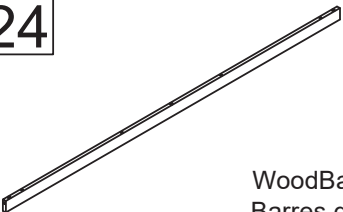
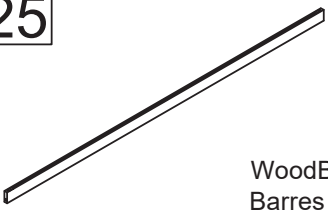
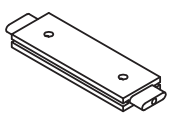
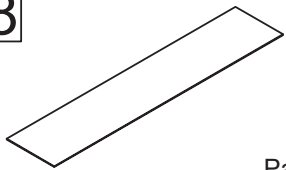
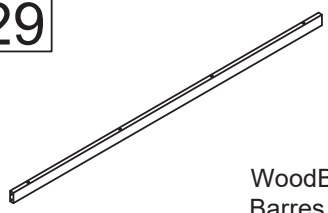
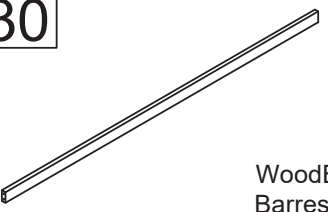
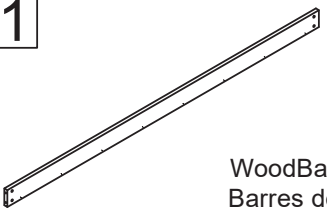
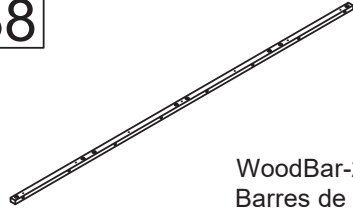
<p><b>1</b></p>  <p>WoodBar-1pc Barres de bois</p>	<p><b>2</b></p>  <p>WoodBar-1pc Barres de bois</p>	<p><b>5</b></p>  <p>Panel-3pcs Planche</p>
<p><b>8</b></p>  <p>WoodBar-1pc Barres de bois</p>	<p><b>9</b></p>  <p>WoodBar-1pc Barres de bois</p>	<p><b>10</b></p>  <p>WoodBar-2pcs Barres de bois</p>
<p><b>12</b></p>  <p>Panel-3pcs Planche</p>	<p><b>15</b></p>  <p>WoodBar-1pc Barres de bois</p>	<p><b>16</b></p>  <p>WoodBar-1pc Barres de bois</p>
<p><b>17</b></p>  <p>WoodBar-1pc Barres de bois</p>	<p><b>21</b></p>  <p>WoodBar-1pc Barres de bois</p>	<p><b>22</b></p>  <p>WoodBar-1pc Barres de bois</p>
<p><b>23</b></p>  <p>Panel-1pc Planche</p>	<p><b>24</b></p>  <p>WoodBar-1pc Barres de bois</p>	<p><b>25</b></p>  <p>WoodBar-3pcs Barres de bois</p>
<p><b>27</b></p>  <p>WoodBar-2pcs Barres de bois</p>	<p><b>28</b></p>  <p>Panel-4pcs Planche</p>	<p><b>29</b></p>  <p>WoodBar-1pc Barres de bois</p>
<p><b>30</b></p>  <p>WoodBar-1pc Barres de bois</p>	<p><b>31</b></p>  <p>WoodBar-2pcs Barres de bois</p>	<p><b>38</b></p>  <p>WoodBar-2pcs Barres de bois</p>

**Part Lists (Box 1)**

**Liste des pièces**

**39**

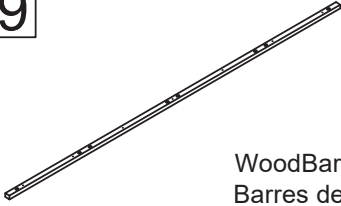

WoodBar-1pc  
Barres de bois



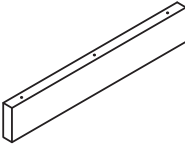

**42**

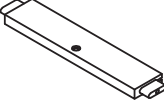

WoodBar-1pc  
Barres de bois

# Part Lists (Box 2)

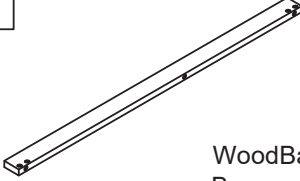
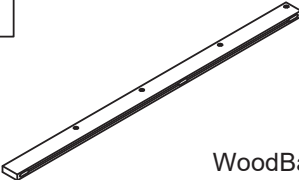
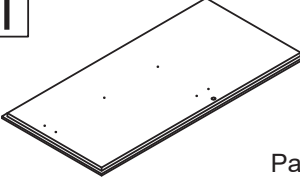
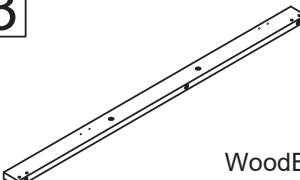
## Liste des pièces

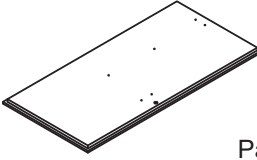
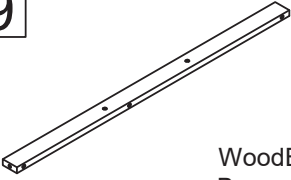
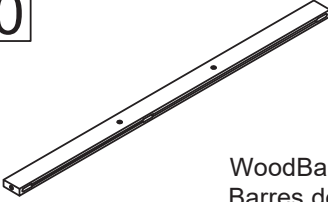
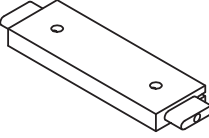
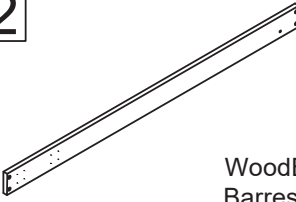
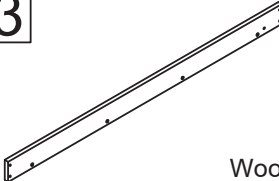
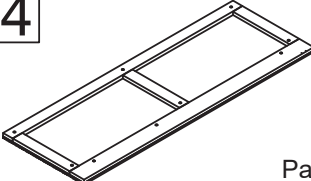
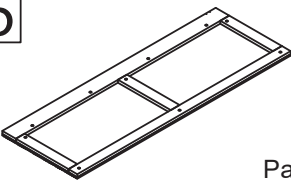
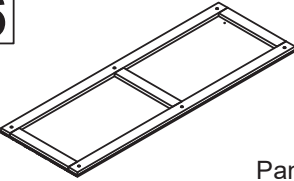
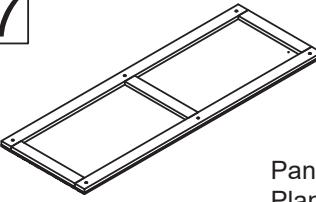
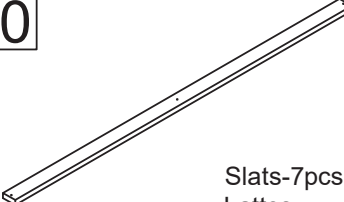
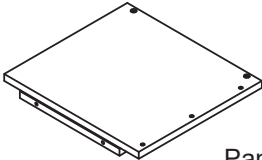
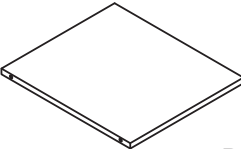
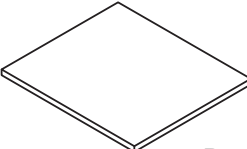
<p><b>3</b></p>  <p>WoodBar-2pcs Barres de bois</p>	<p><b>4</b></p>  <p>WoodBar-2pcs Barres de bois</p>	<p><b>6</b></p>  <p>WoodBar-1pc Barres de bois</p>
<p><b>7</b></p>  <p>WoodBar-1pc Barres de bois</p>	<p><b>11</b></p>  <p>Panel-1pc Planche</p>	<p><b>13</b></p>  <p>WoodBar-1pc Barres de bois</p>
<p><b>14</b></p>  <p>WoodBar-1pc Barres de bois</p>	<p><b>18</b></p>  <p>Panel-1pc Planche</p>	<p><b>19</b></p>  <p>WoodBar-1pc Barres de bois</p>
<p><b>20</b></p>  <p>WoodBar-1pc Barres de bois</p>	<p><b>26</b></p>  <p>WoodBar-4pcs Barres de bois</p>	<p><b>32</b></p>  <p>WoodBar-1pc Barres de bois</p>
<p><b>33</b></p>  <p>WoodBar-1pc Barres de bois</p>	<p><b>34</b></p>  <p>Panel-1pc Planche</p>	<p><b>35</b></p>  <p>Panel-1pc Planche</p>
<p><b>36</b></p>  <p>Panel-1pc Planche</p>	<p><b>37</b></p>  <p>Panel-1pc Planche</p>	<p><b>40</b></p>  <p>Slats-7pcs Lattes</p>
<p><b>41</b></p>  <p>Panel-1pc Planche</p>	<p><b>43</b></p>  <p>Panel-2pcs Planche</p>	<p><b>44</b></p>  <p>Panel-1pc Planche</p>

# Part Lists (Box 2)

## Liste des pièces

45

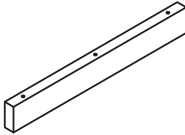

WoodBar-1pc  
Barres de bois



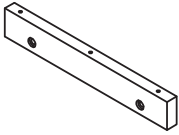









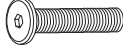











46

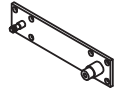

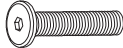
WoodBar-2pcs  
Barres de bois

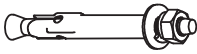

# Hardware Lists (Box 2)

## Liste du matériel

<b>A1</b>  <p>Ø1/4*110mm</p>	<b>A2</b>  <p>Ø1/4*60mm</p>	<b>A3</b>  <p>Ø1/4*30mm</p>	
<p>Hex-Head bolt (38pcs) Boulon</p>	<p>Hex-Head bolt (24pcs) Boulon</p>	<p>Hex-Head bolt (50pcs) Boulon</p>	
<b>A4</b>  <p>Ø1/4*12mm</p>	<b>B1</b>  <p>Ø1/4**9.5*13mm</p>	<b>B2</b>  <p>Ø1/4**9.5*10mm</p>	
<p>Hex-Head bolt (16pcs) Boulon</p>	<p>Horizontal-Hole bolt (54pcs) Boulons à trou horizontal</p>	<p>Horizontal-Hole bolt (8pcs) Boulons à trou horizontal</p>	
<b>C1</b>  <p>Ø4*50mm</p>	<b>C2</b>  <p>Ø4*35mm</p>	<b>C3</b>  <p>Ø4*30mm</p>	
<p>Wood screws (9pcs) Vis</p>	<p>Wood screws (37pcs) Vis</p>	<p>Wood screws (3pcs) Vis</p>	
<b>D</b> 	<b>E</b>  <p>Ø4*12mm</p>	<b>F1</b> 	
<p>Handle (1pc) Poignée</p>	<p>Handle Screws (2pcs) Vis poignée</p>	<p>Metal leg (L) (1pcs) Pied en métal (L)</p>	
<b>F2</b> 	<b>G</b> 	<b>H</b>  <p>Ø19/Ø8*2mm</p>	
<p>Metal leg (R) (1pc) Pied en métal (R)</p>	<p>Nut (6pcs) Écrou hexagonal</p>	<p>Spring washer (2pcs) Rondelle</p>	
<b>I1</b> 	<b>I2</b> 	<b>J</b> 	
<p>Metal corner link (L) (1pc) Liens d'angle en métal(L)</p>	<p>Metal corner link (R) (1pc) Liens d'angle en métal(R)</p>	<p>Metal corner link (2pcs) Liens d'angle en métal</p>	
<b>K</b> 	<b>L</b> <p>350N</p> 	<b>M</b>  <p>M8*40mm</p>	
<p>Bearings (2pcs) Roulements(L)</p>	<p>Piston steam (2pcs) Vapeur à piston</p>	<p>Hex-Head bolt (2pcs) Boulon</p>	
<b>N</b>  <p>Ø3.5*15mm</p>	<b>O1</b> 	<b>O2</b> 	
<p>Wood screws (36pcs) Vis</p>	<p>Angle metal (8pcs) Cornière en métal</p>	<p>Angle metal (2pcs) Cornière en métal</p>	
<b>P</b> 	<b>Q</b>  <p>Ø4*15mm</p>	<b>R</b> 	
<p>Expansion screw bolts (4sets) Boulons à vis d'expansion</p>	<p>Wood screws (8pcs) Vis</p>	<p>Double Roller Catch (2sets) Cierre De Doble Rodillo</p>	
			<p>07/46</p>

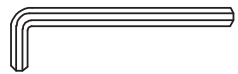

# Hardware Lists (Box 2)

## Liste du matériel

<b>S</b>  Ø3*15mm	<b>T</b> 	<b>U</b>  K4mm
Wood screws (8pcs) Vis	Open wrench 13mm (1pcs) Clé plate 13mm	Allen key (2pcs) Clé Allen

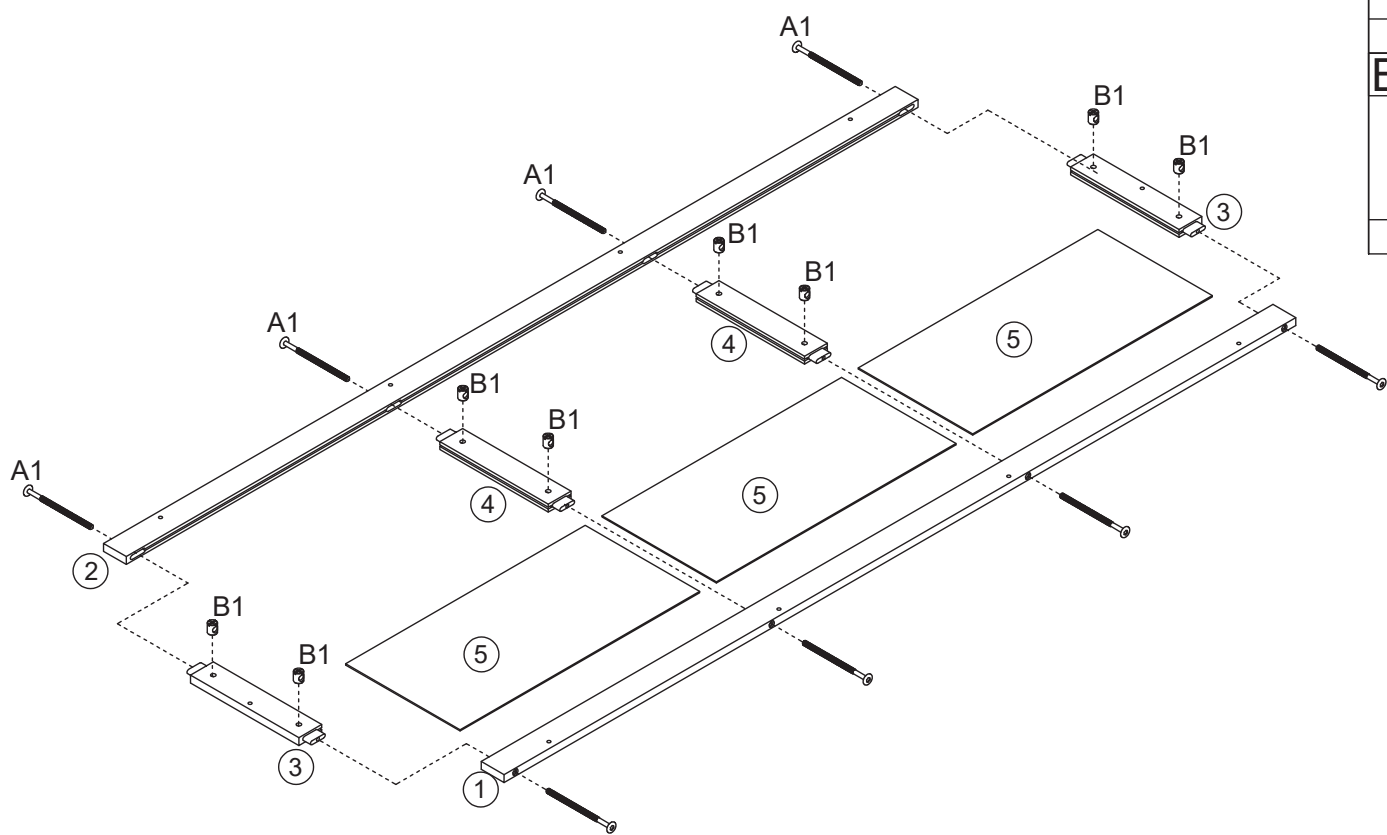

**Step 1**  
**Étape 1**



<b>A1</b>	
8PCS	
<b>B1</b>	
8PCS	

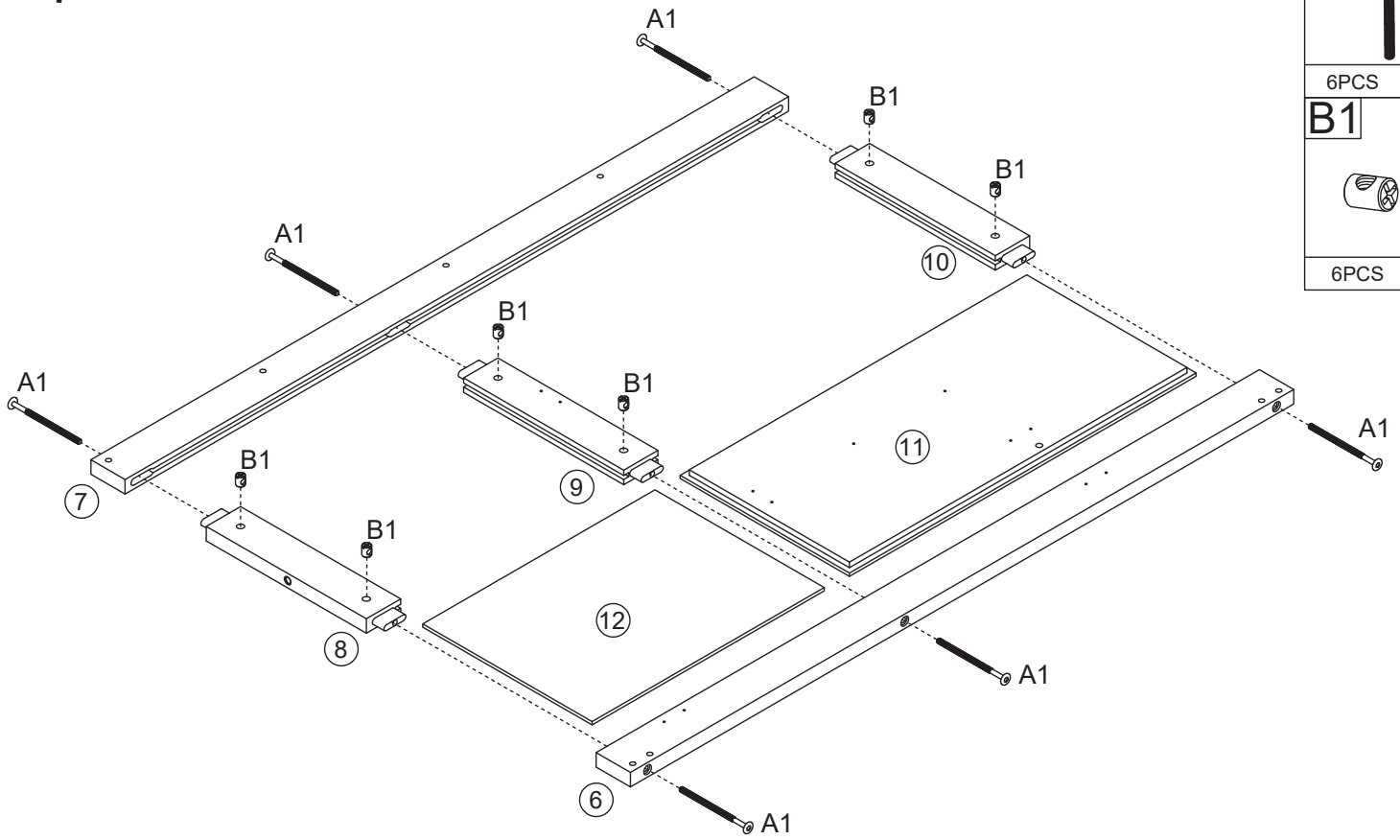

**Step 2**  
**Étape 2**



<b>A1</b>	
6PCS	
<b>B1</b>	
6PCS	

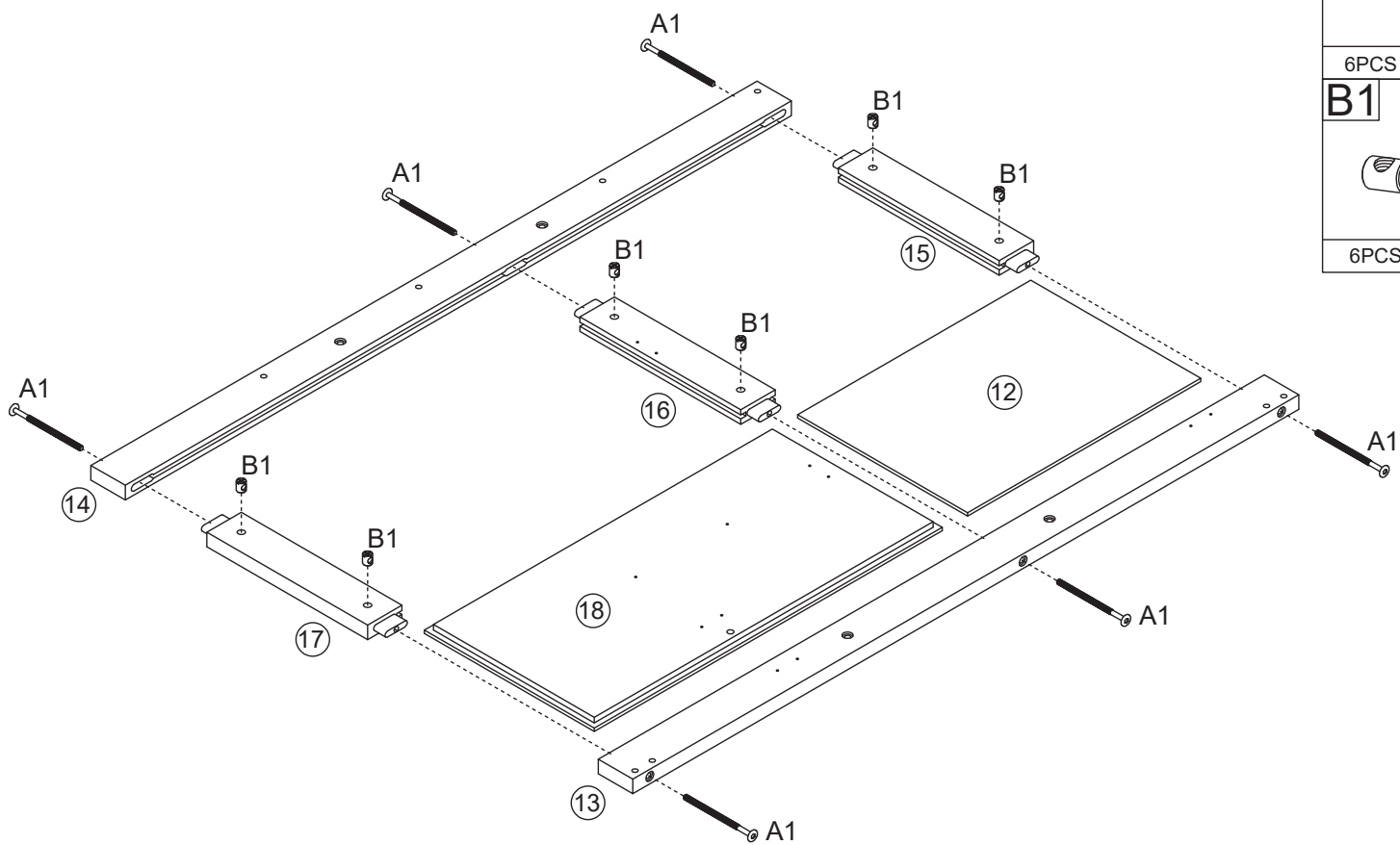

**Step 3**  
**Étape 3**

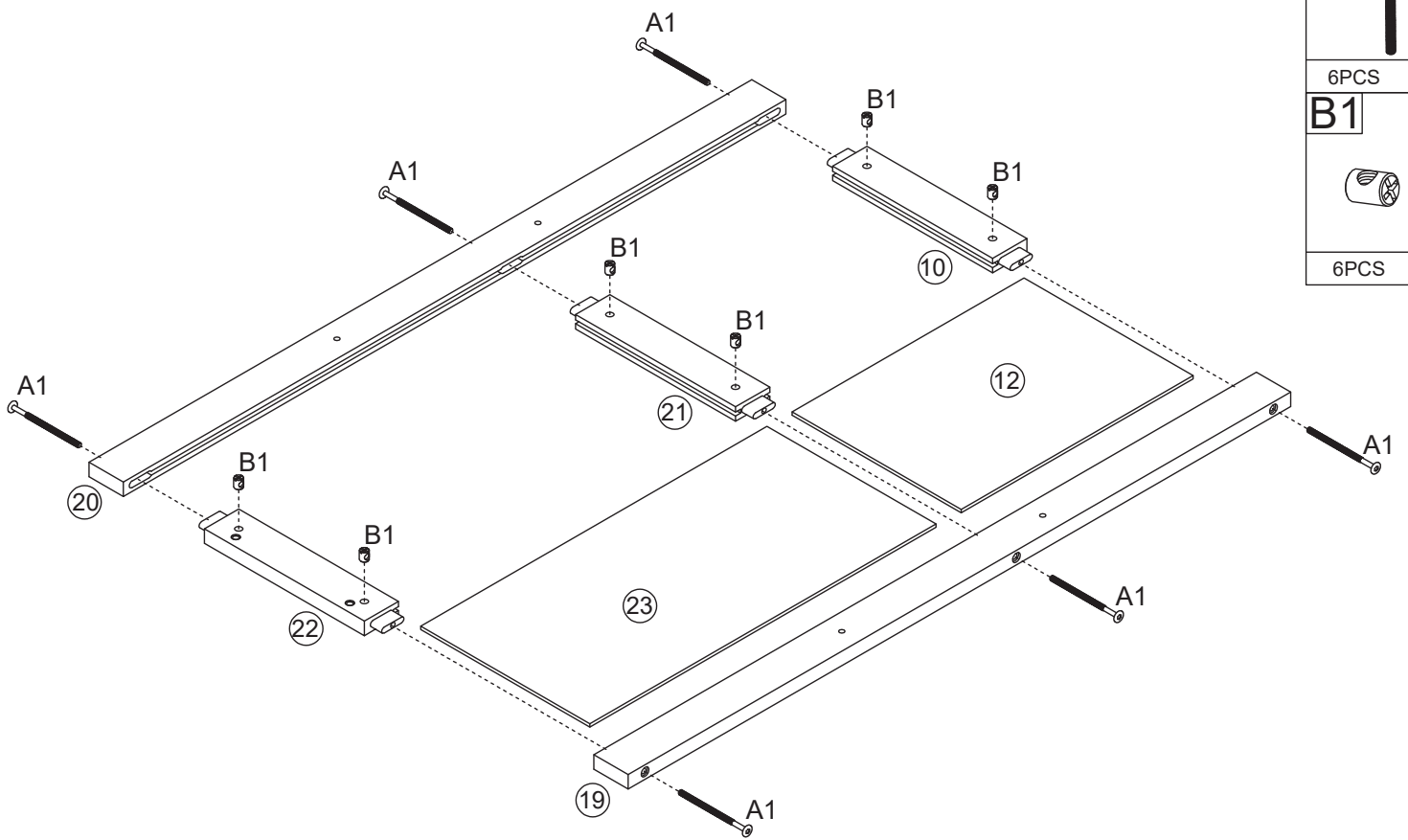

<b>A1</b>	
6PCS	
<b>B1</b>	
6PCS	

**Step 4**  
**Étape 4**



<b>A1</b>	
6PCS	
<b>B1</b>	
6PCS	

**Step 5**  
**Étape 5**

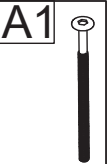
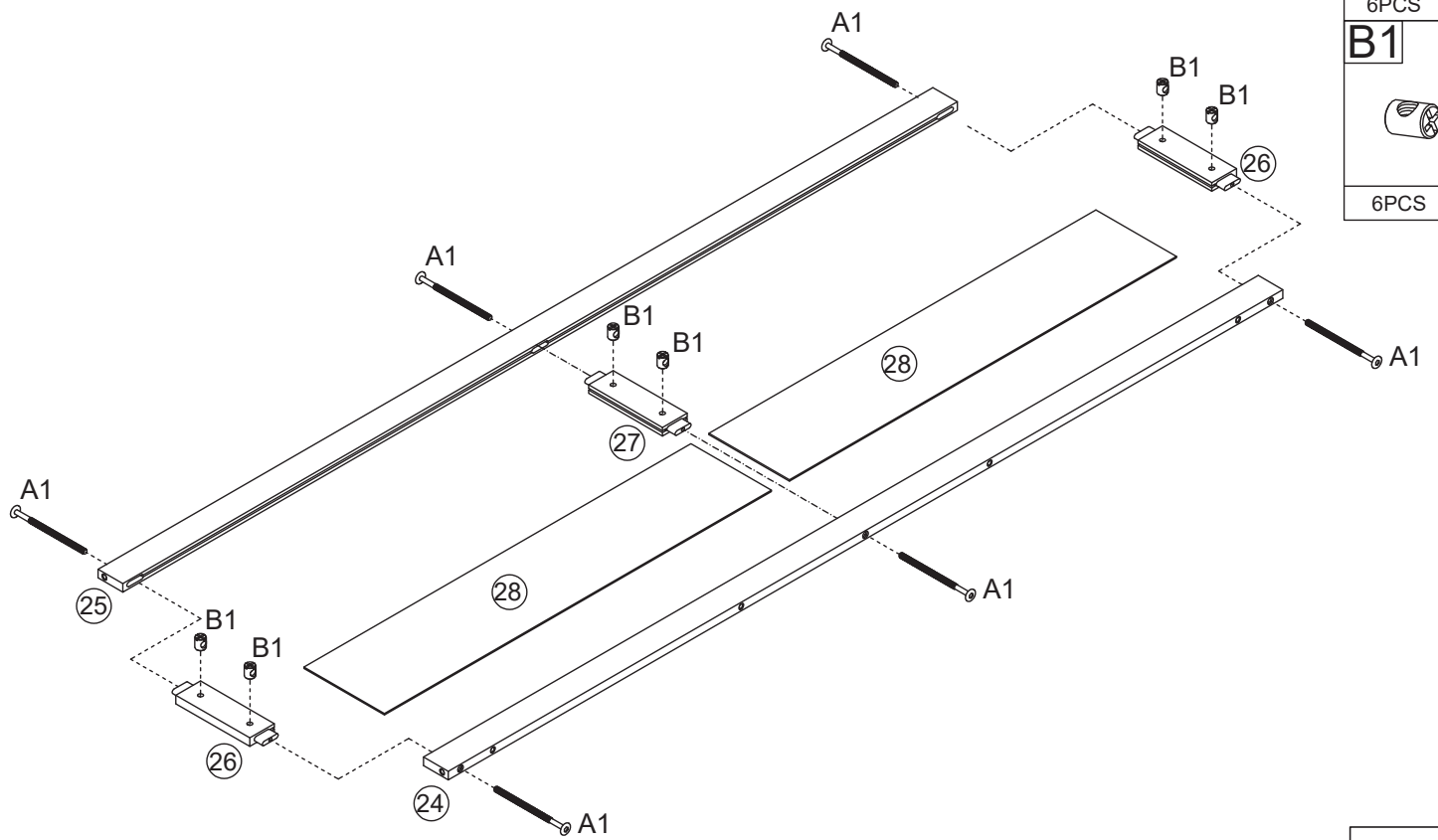



6PCS

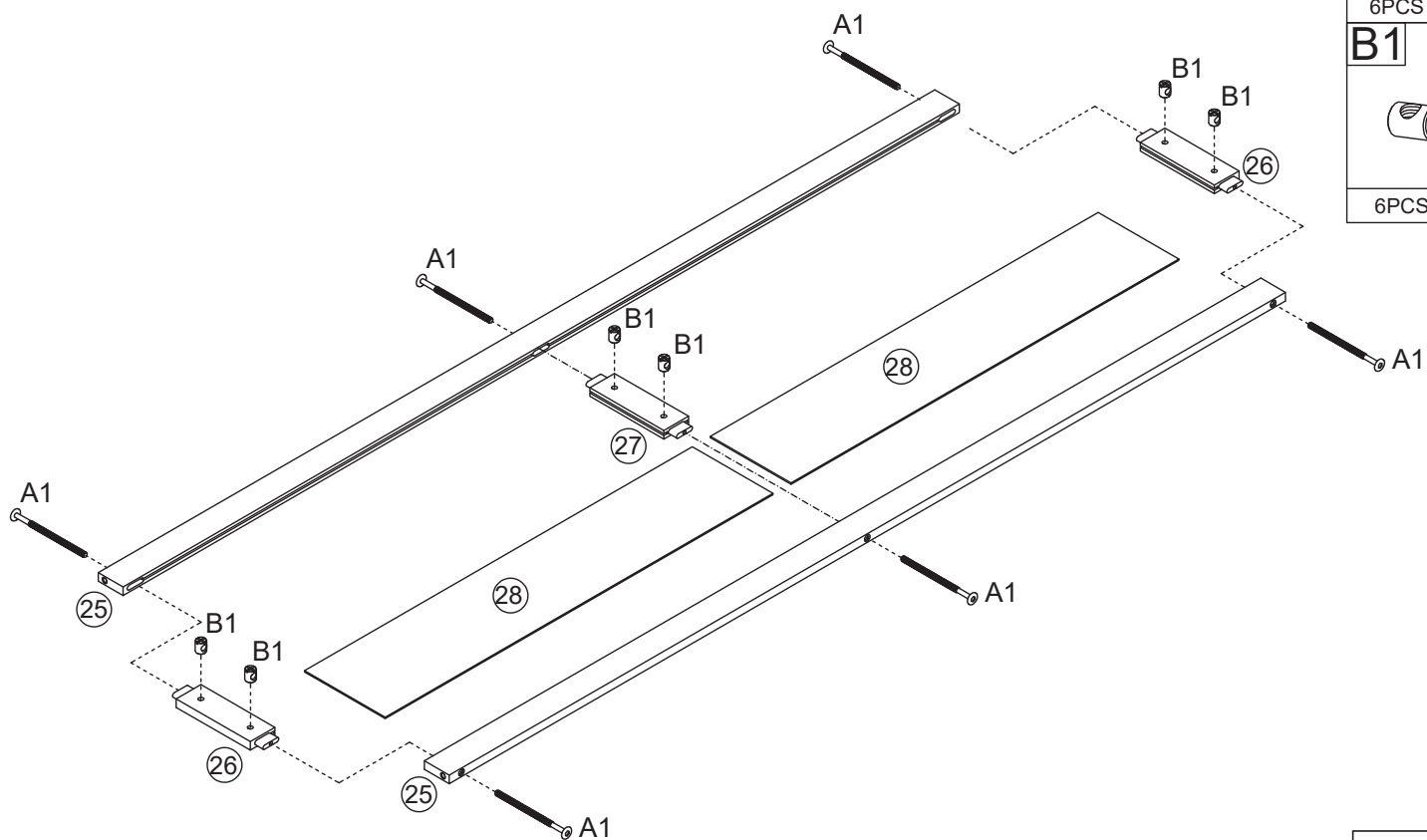

6PCS

**Step 6**  
**Étape 6**



<b>A1</b>	
6PCS	
<b>B1</b>	
6PCS	



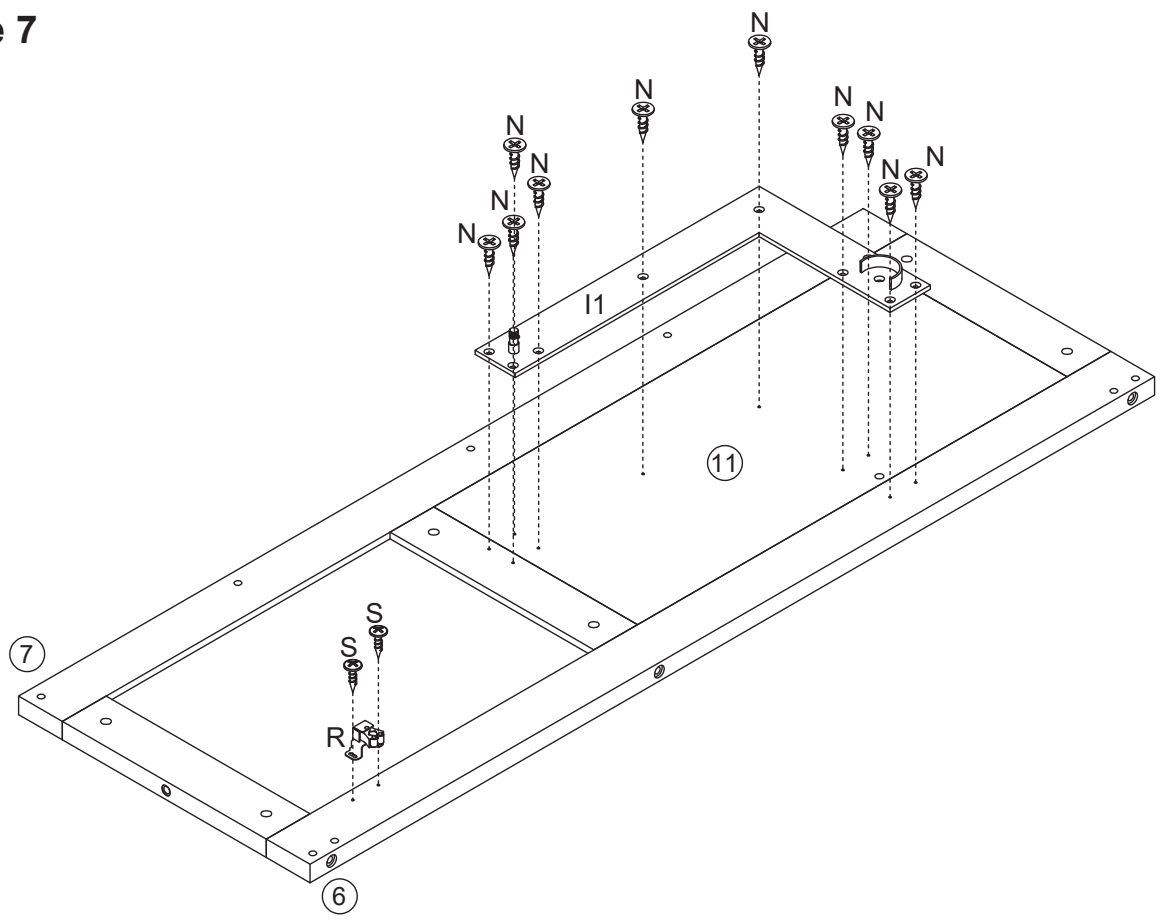

Step 7  
Étape 7

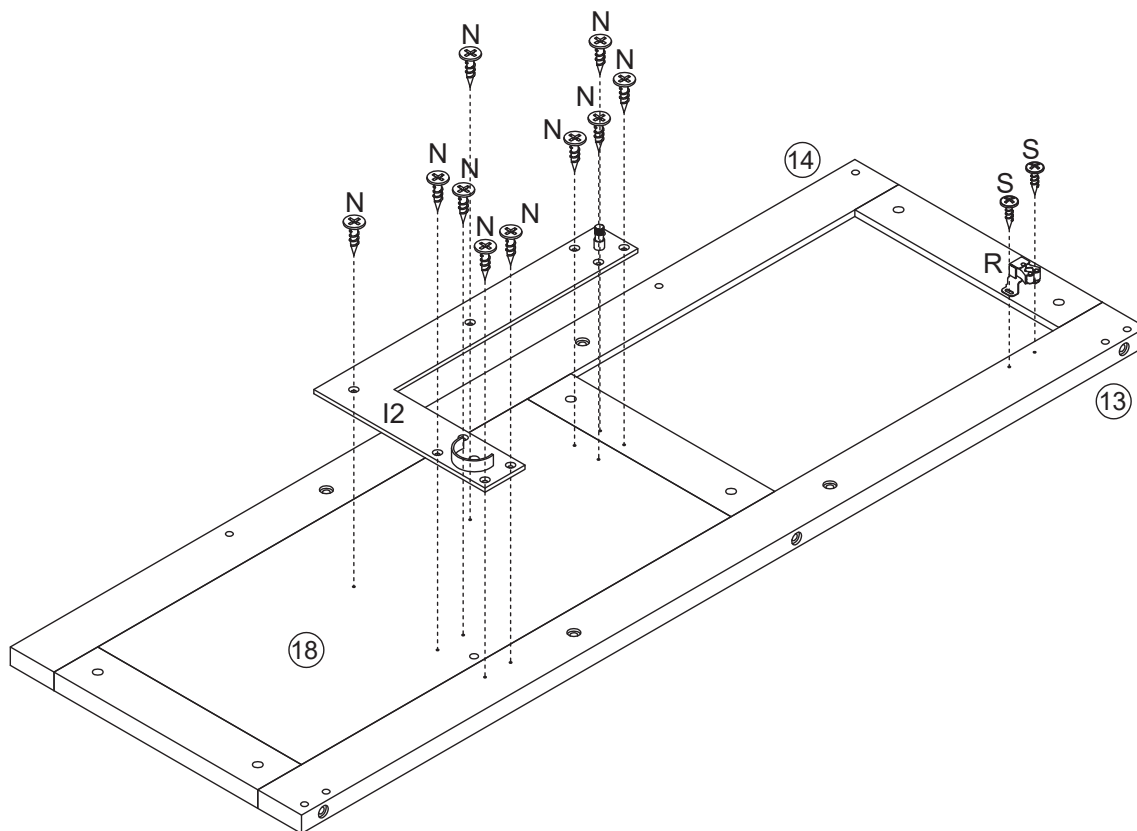

I1	
1PC	
N	
10PCS	
R	
1PC	
S	
2PCS	

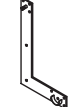
Step 8  
Étape 8



I2	
1PC	
N	
10PCS	
R	
1PC	
S	
2PCS	

Step 9  
Étape 9

C2



16PCS

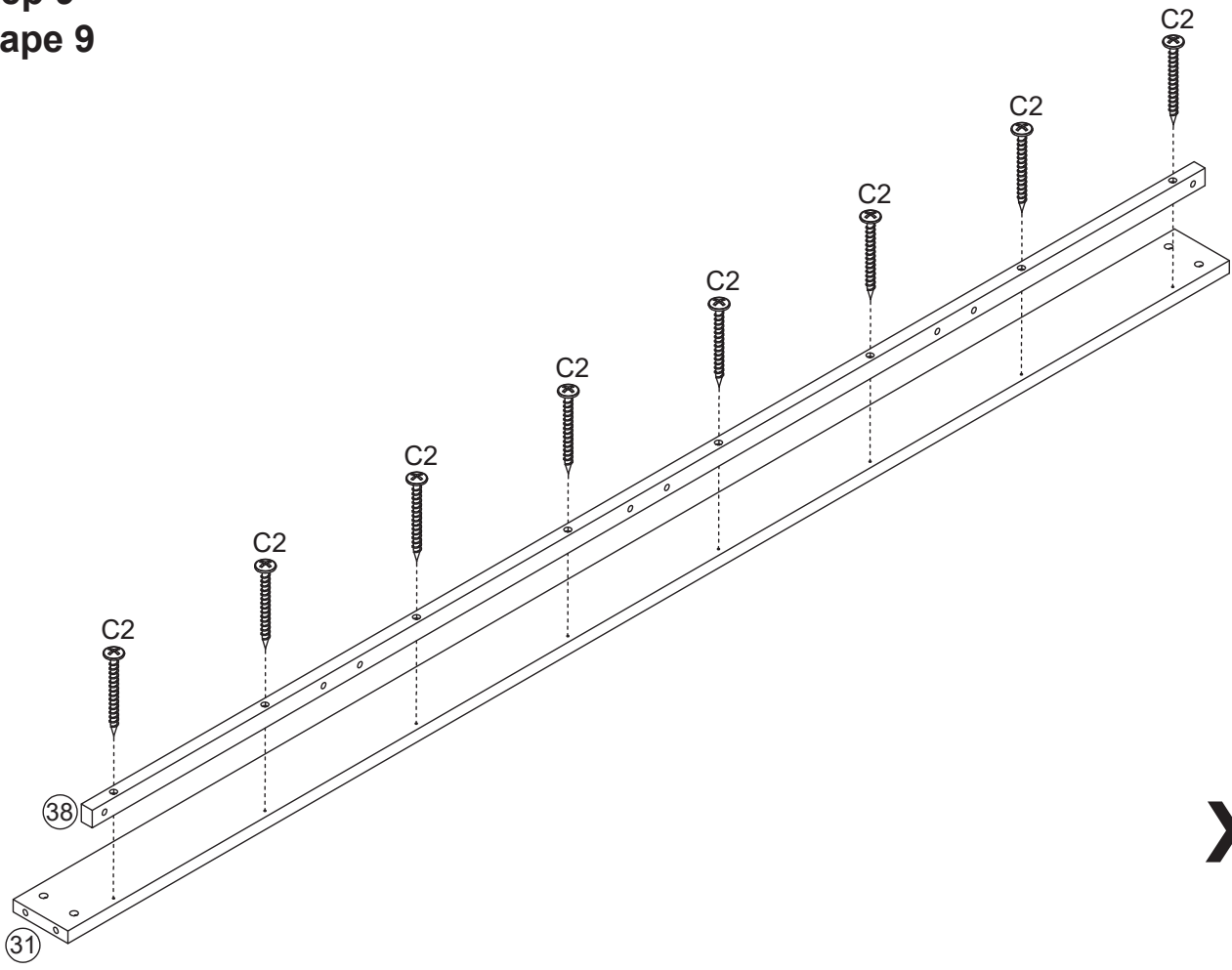

X2

Step 10  
Étape 10

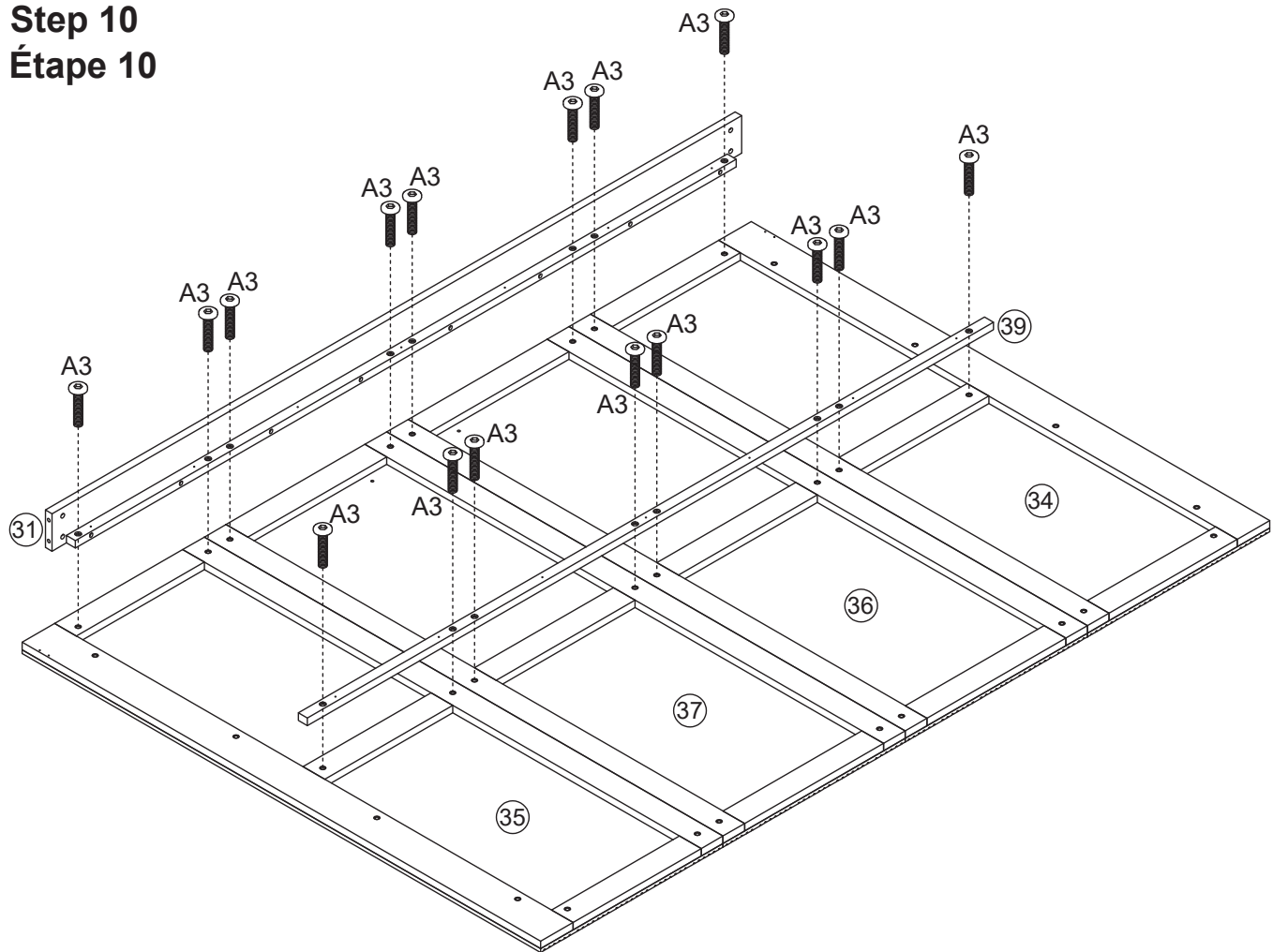

A3



16PCS

Step 11  
Étape 11

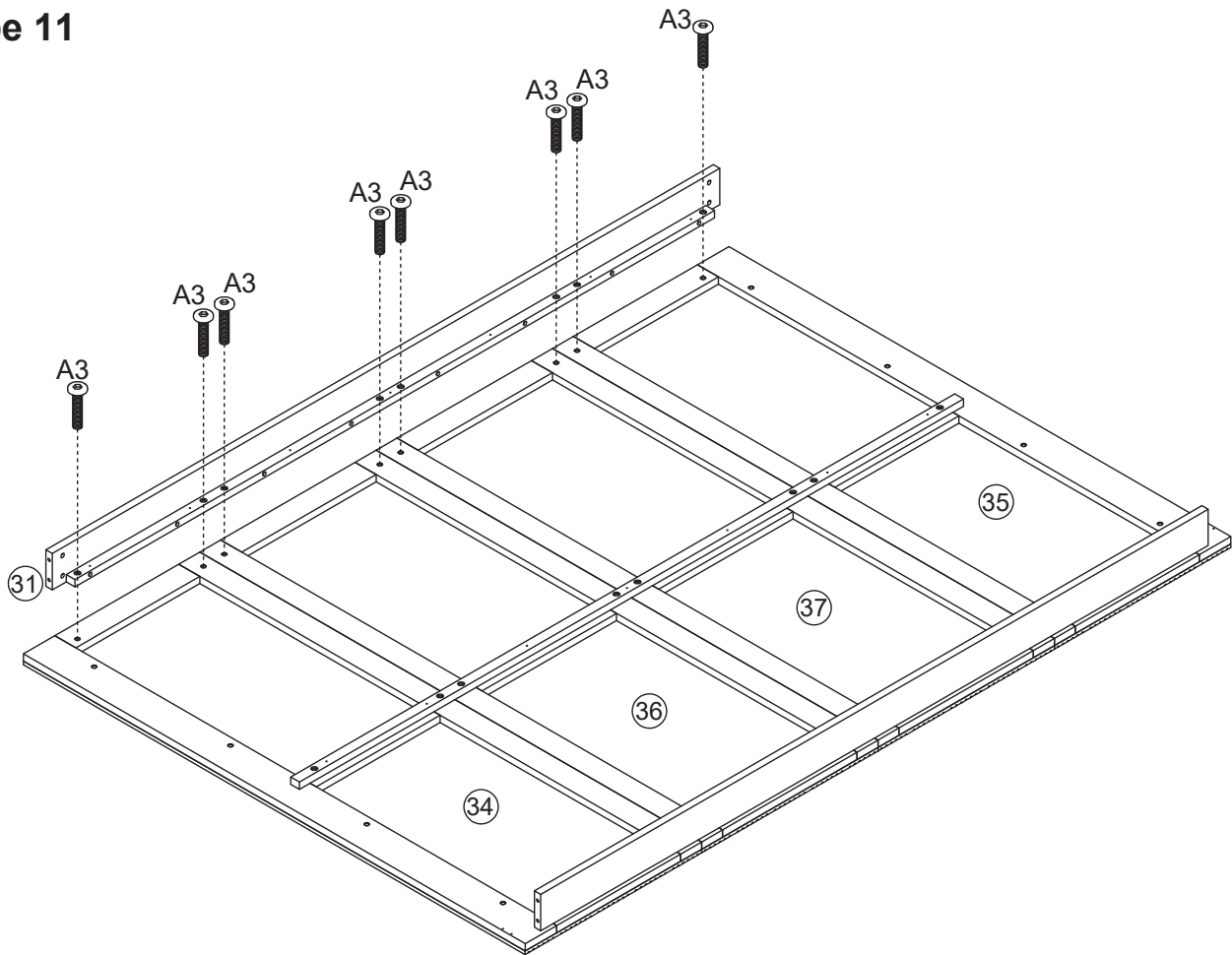



A3



8PCS

**Step 12**  
**Étape 12**

<b>A2</b>	<b>B1</b>
	
8PCS	8PCS

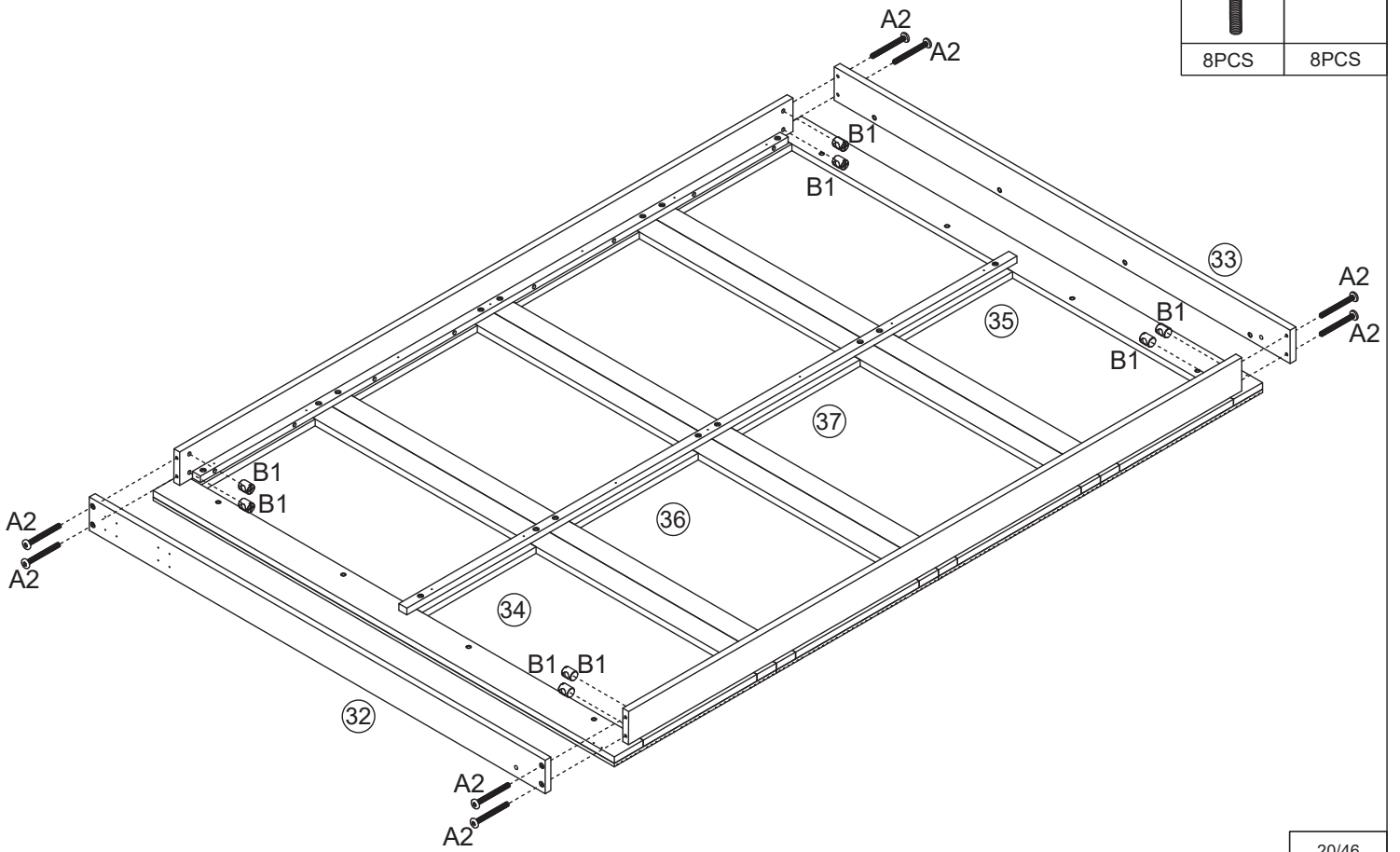

**Step 13**  
**Étape 13**

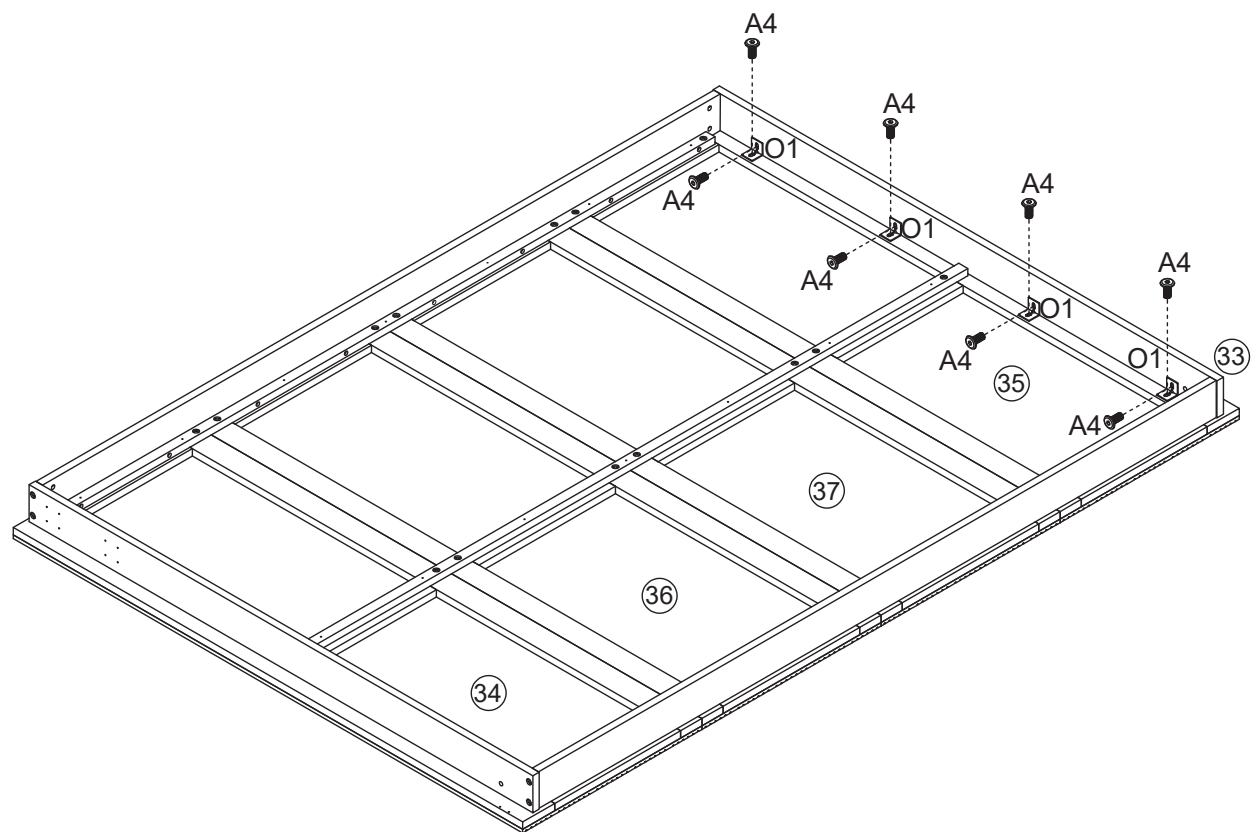

**A4**



8PCS

**O1**



4PCS

Step 14  
Étape 14

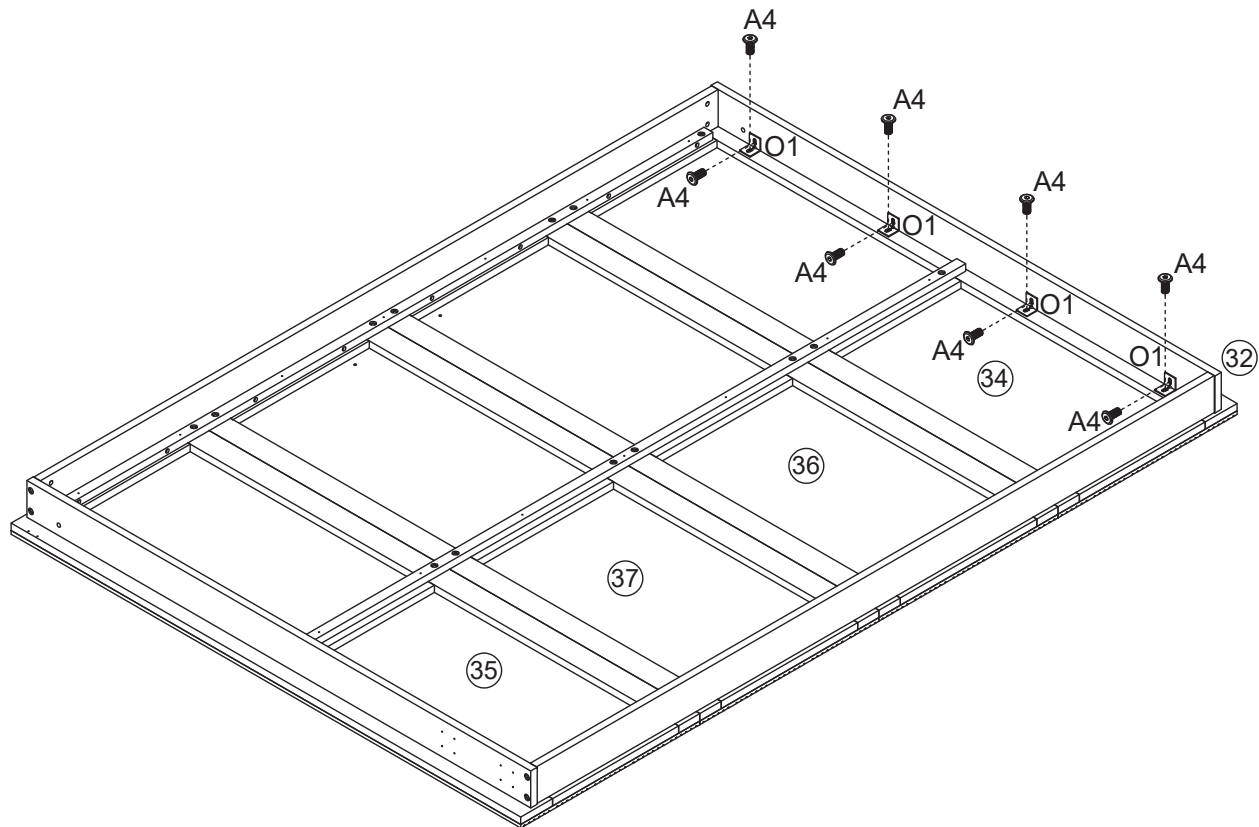

A4



8PCS

O1



4PCS

**Step 15**  
**Étape 15**

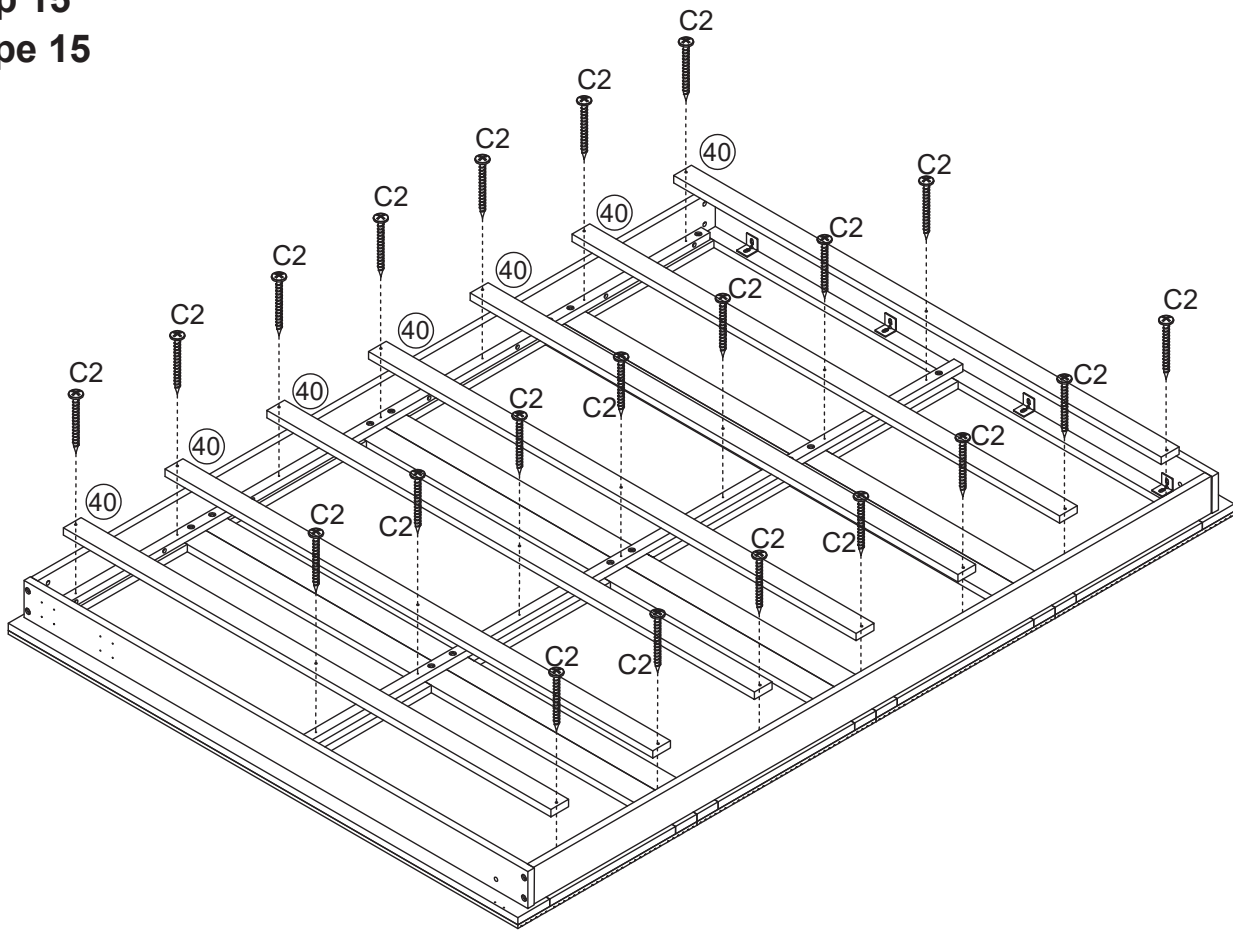

**C2**



21PCS

**Step 16**  
**Étape 16**

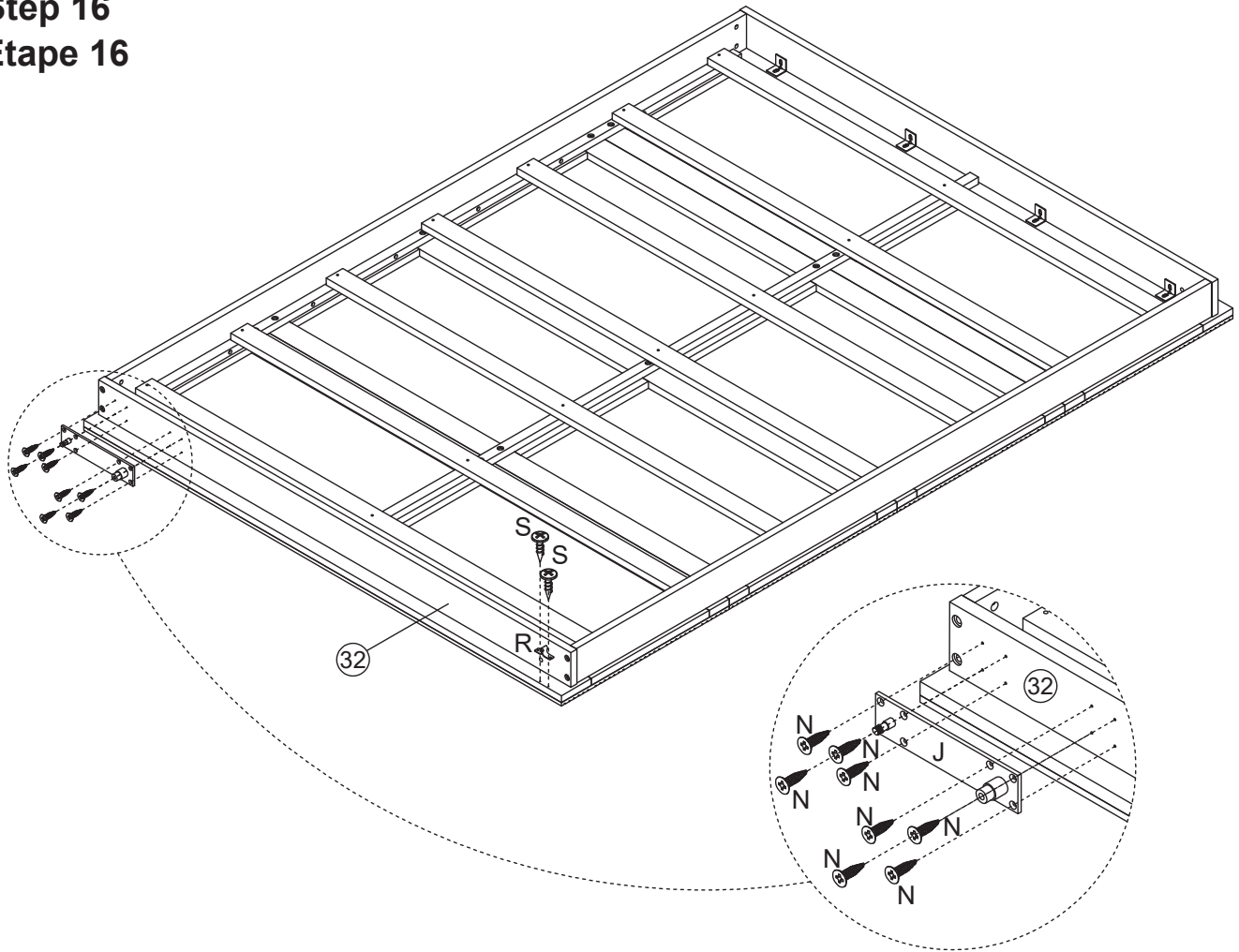

**J**



1PC

**N**



8PCS

**R**



1PC

**S**



2PCS

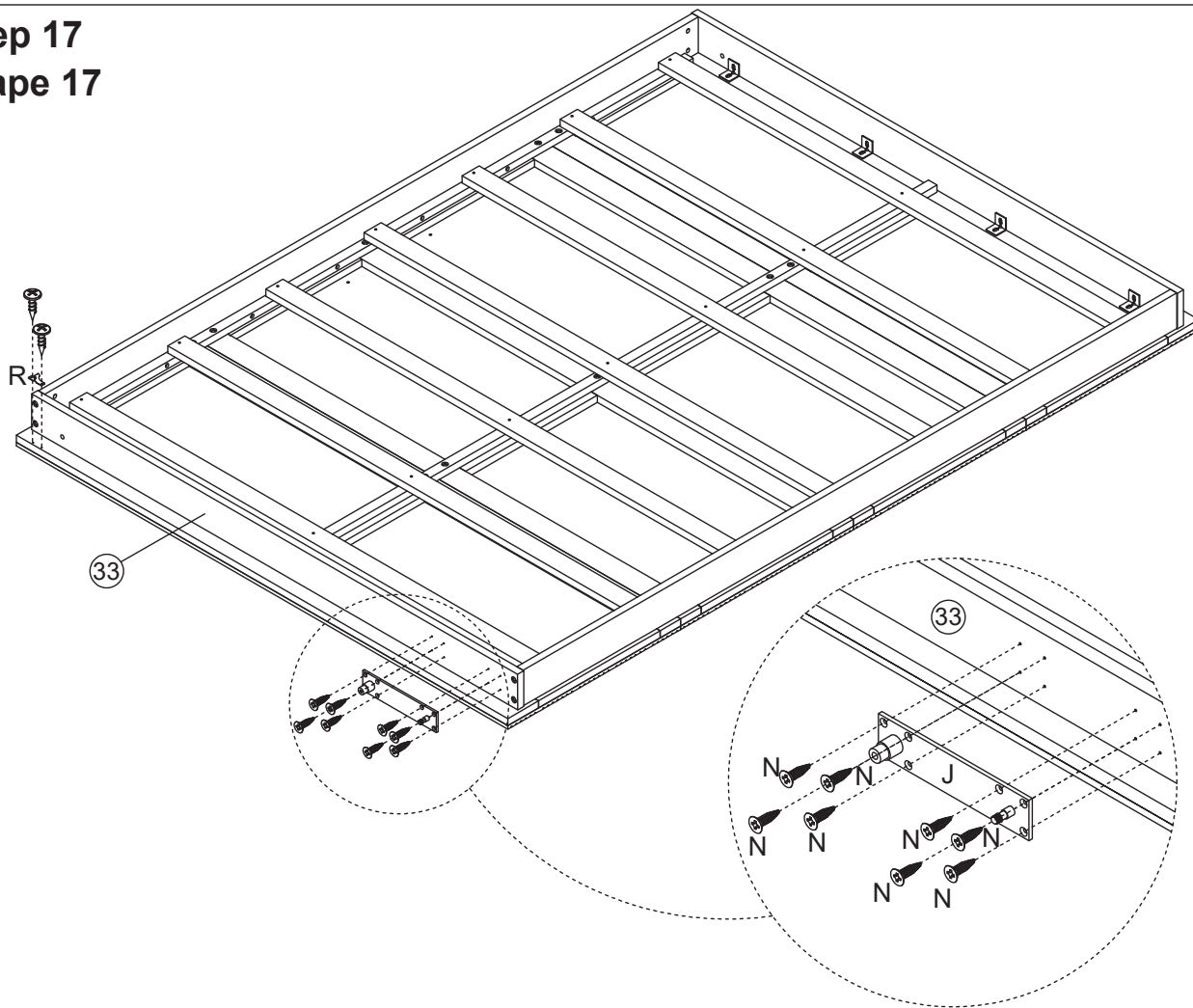

**Step 17**  
**Étape 17**

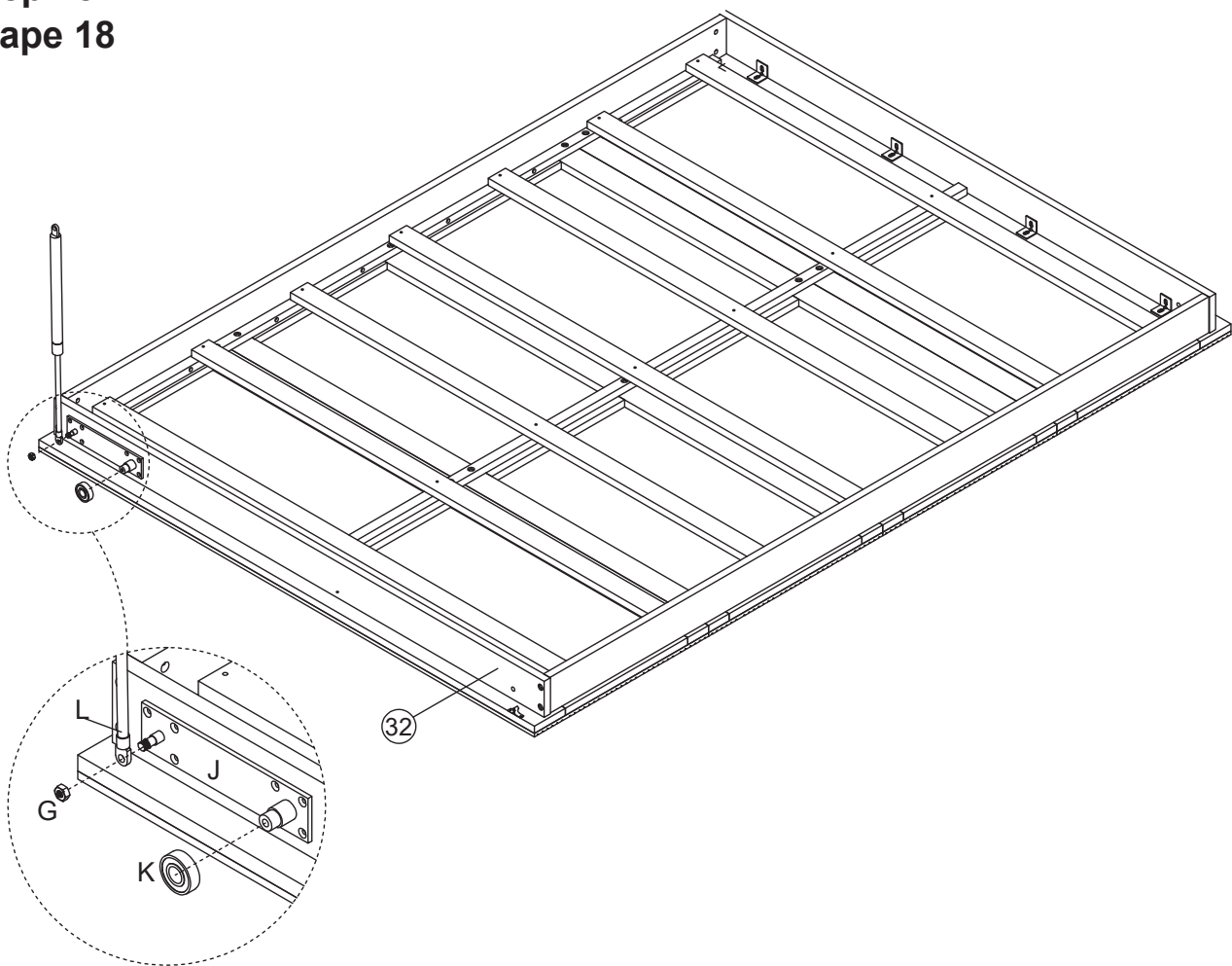

<b>J</b>
1PC
<b>N</b>
8PCS
<b>R</b>
1PC
<b>S</b>
2PCS
25/46

Step 18  
Étape 18





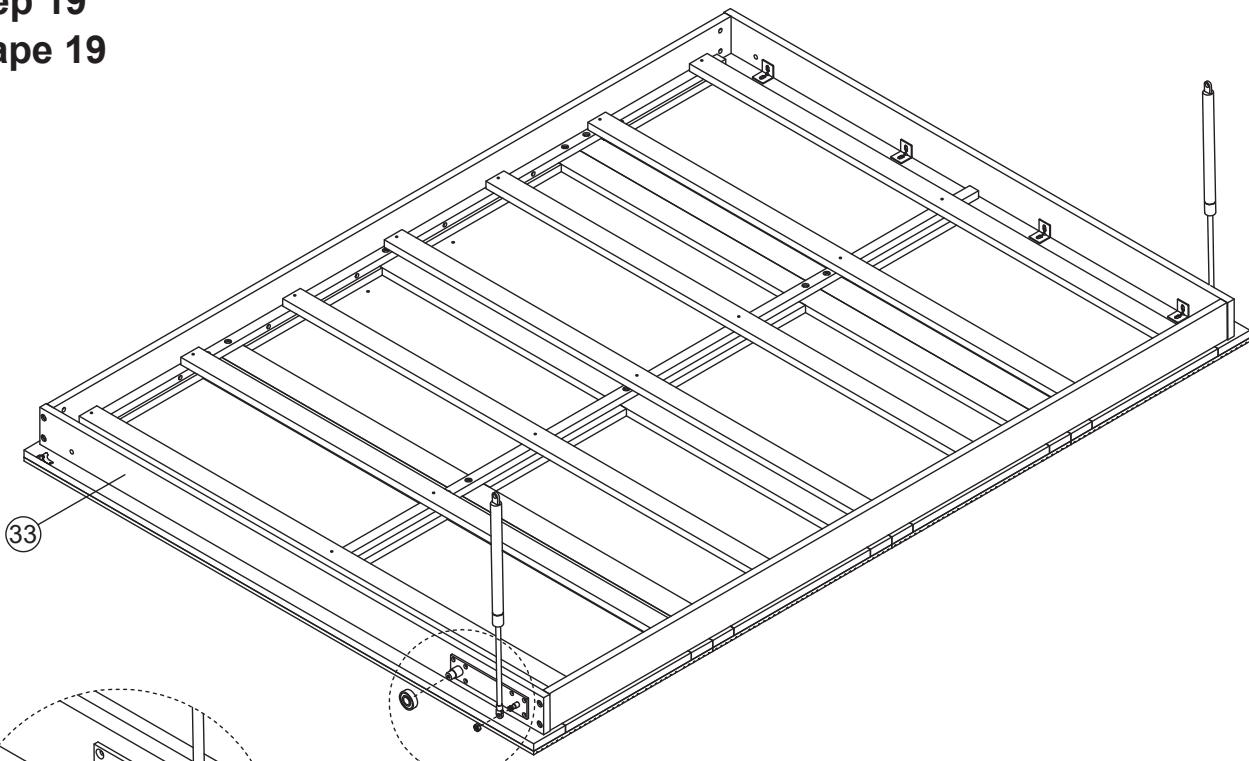

- G**  
  
1PC
- K**  
  
1PC
- L**  
  
1PC

**Step 19**  
**Étape 19**

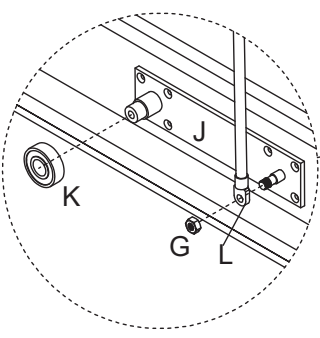

33



- G**  
  
1PC
- K**  
  
1PC
- L**  
  
1PC

Step 20  
Étape 20

C3



3PCS

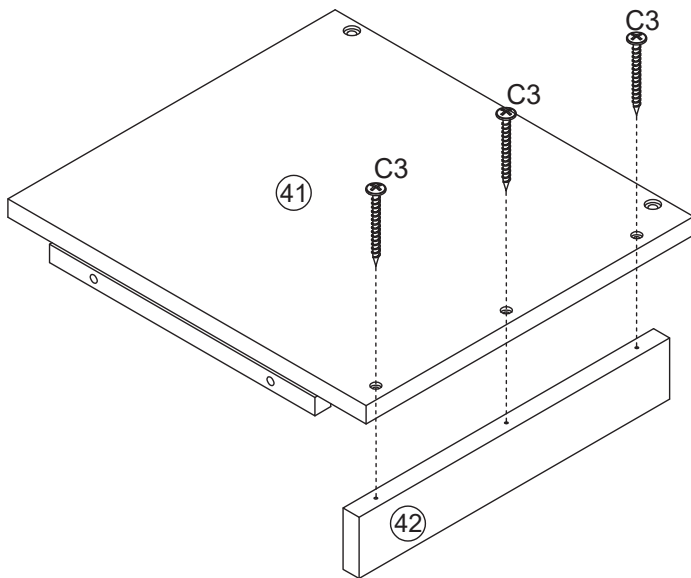

Step 21  
Étape 21

C1



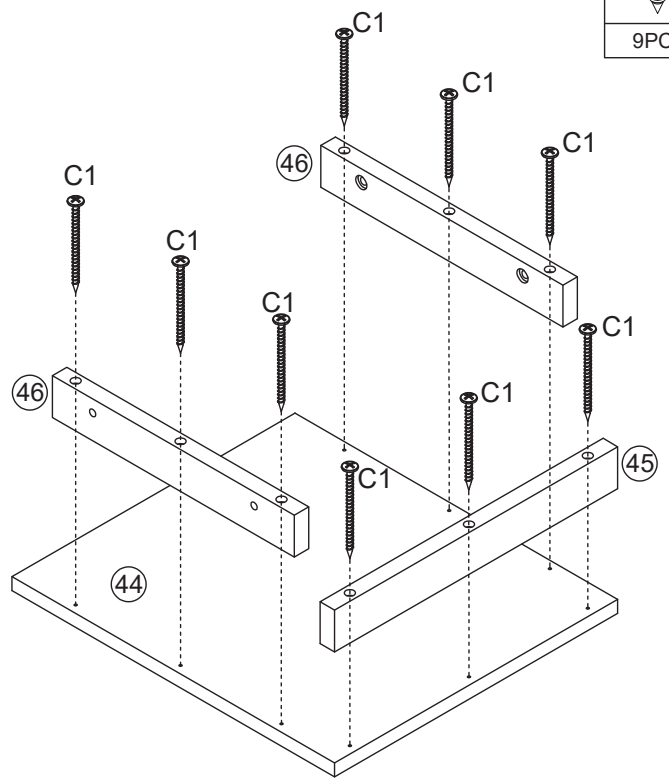

9PCS

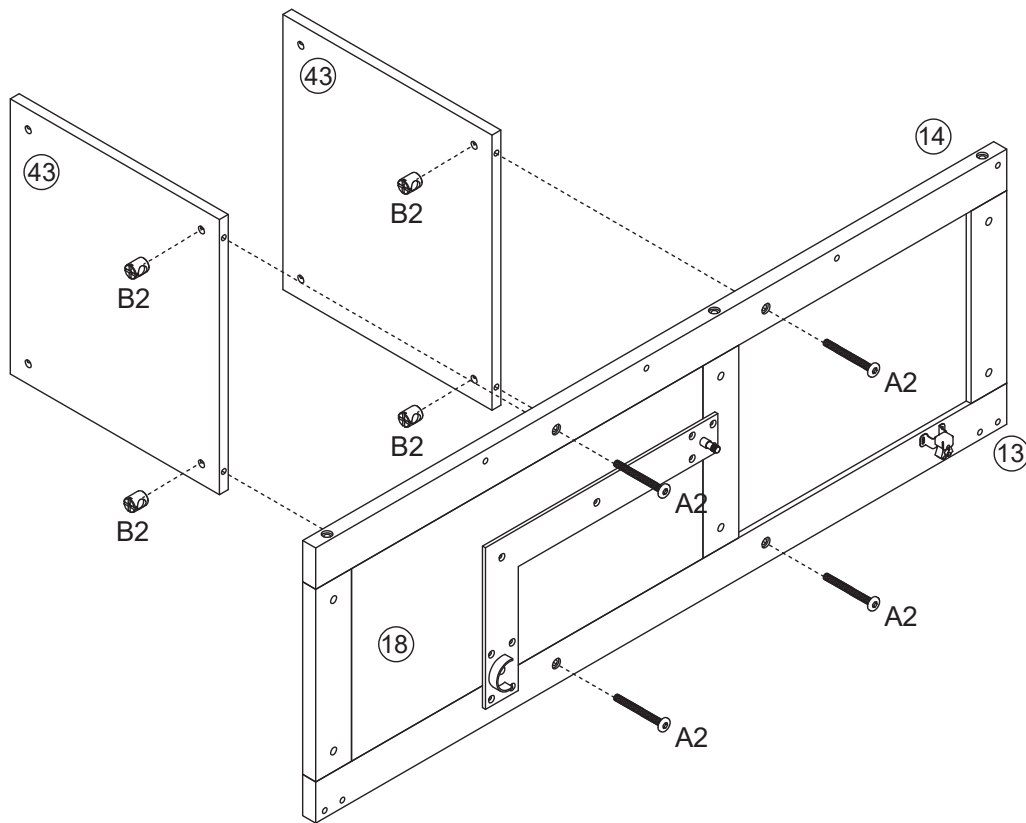

**Step 22**  
**Étape 22**



<b>A2</b>	<b>B2</b>
	
4PCS	4PCS

**Step 23**  
**Étape 23**

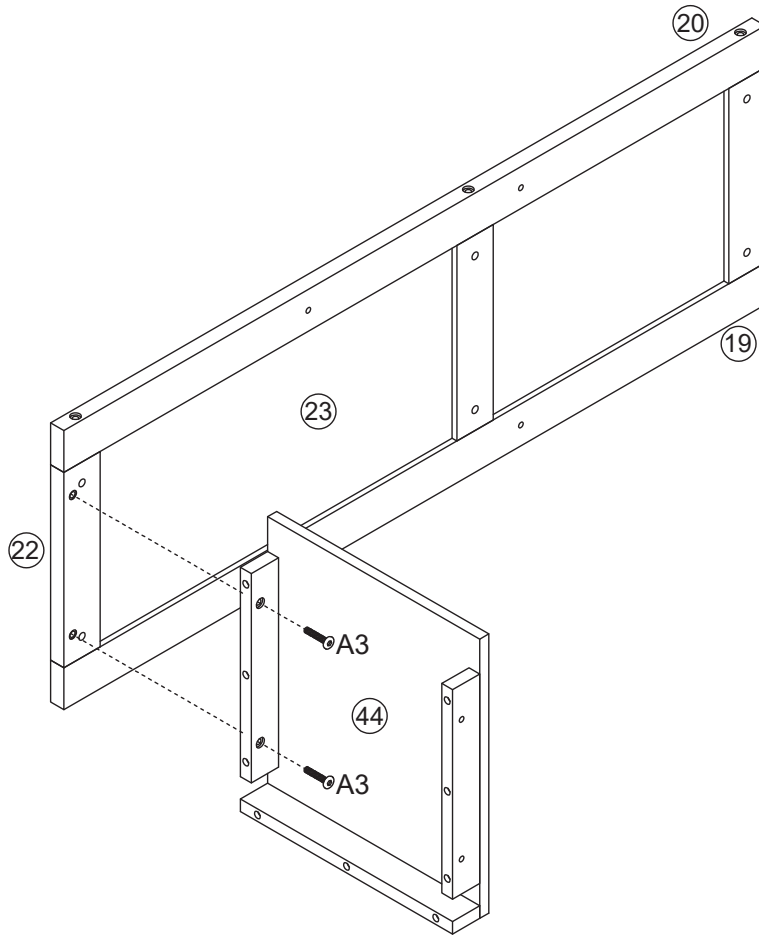





**A3**

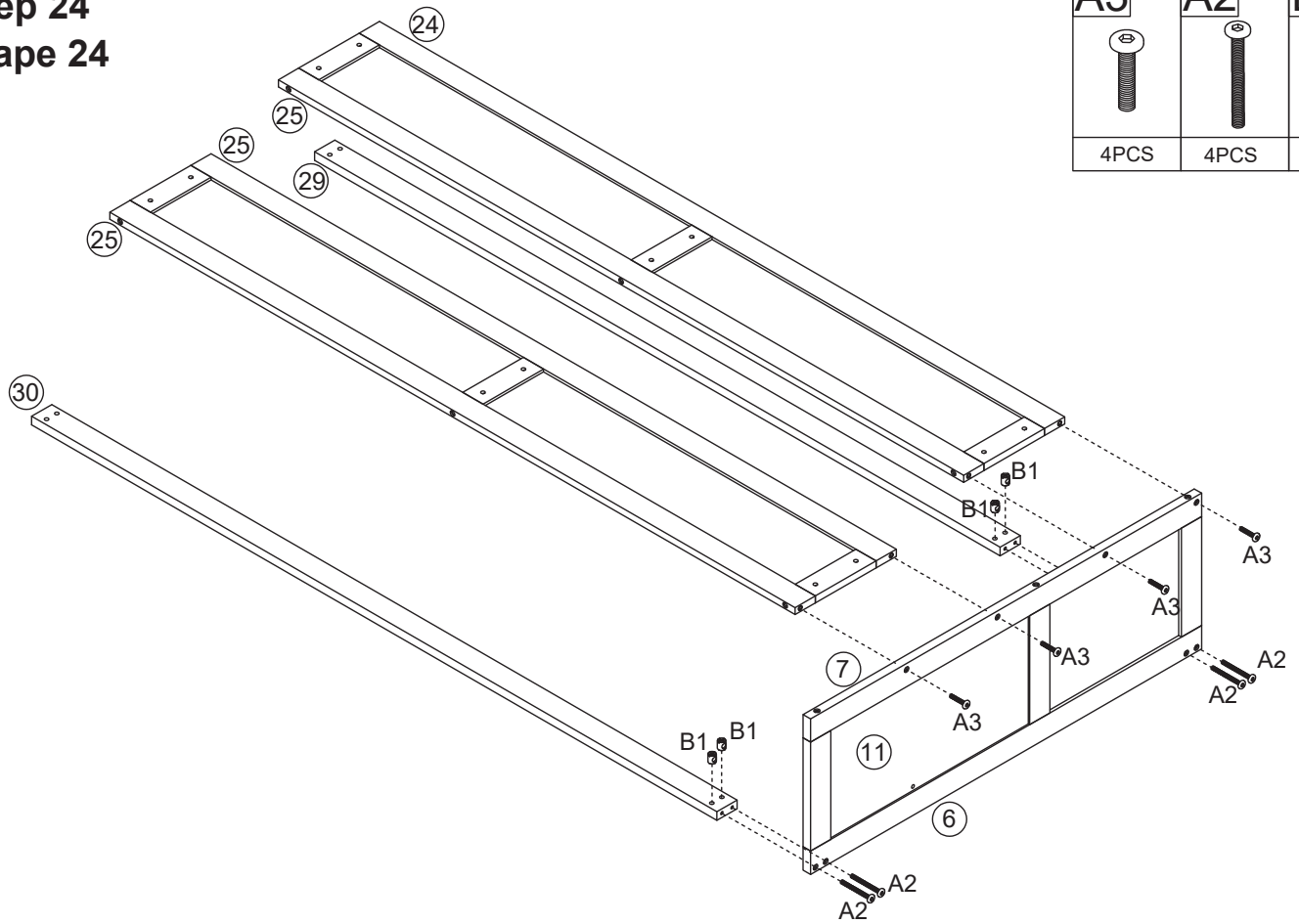

2PCS



**Step 24**  
**Étape 24**

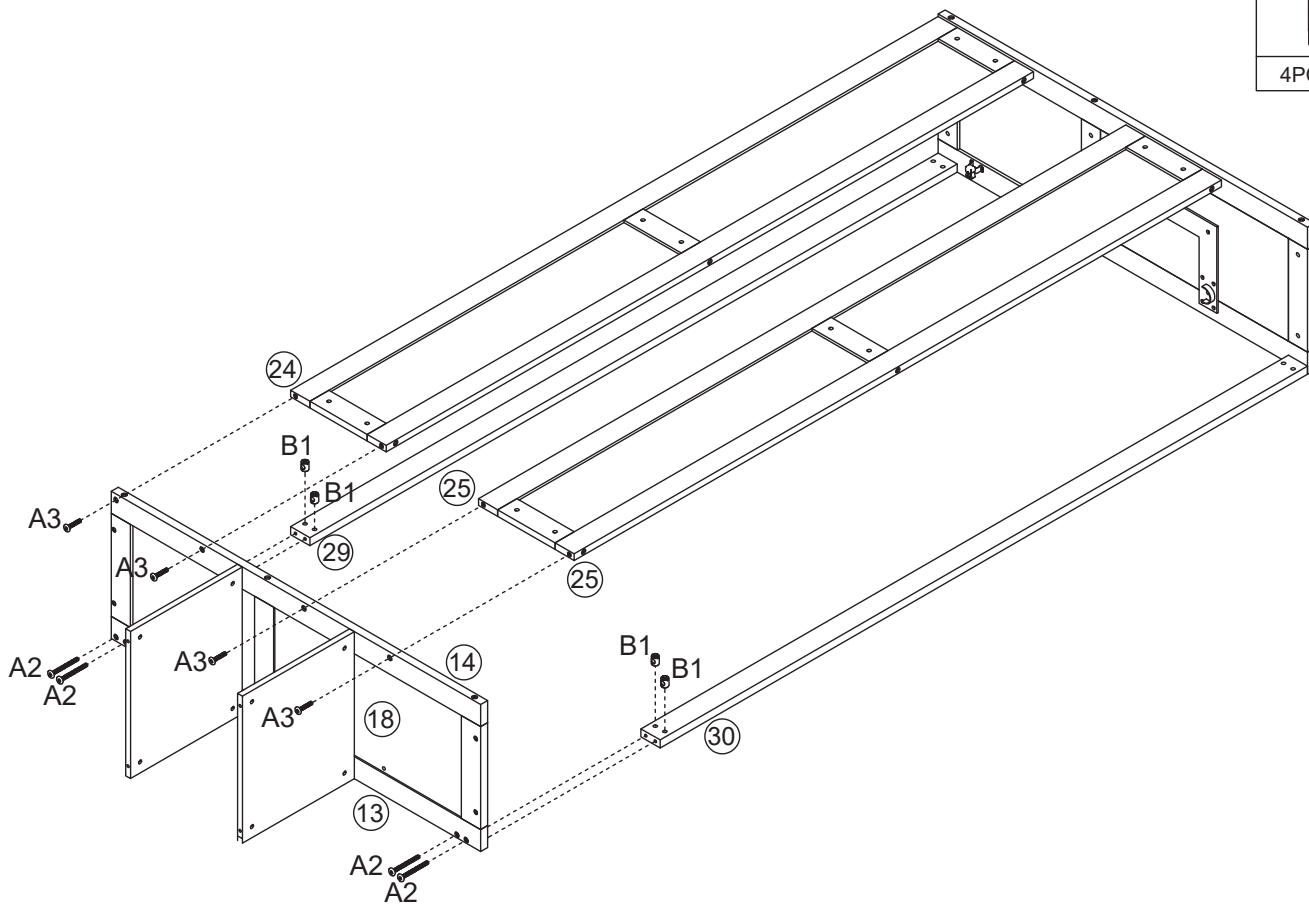

A3	A2	B1
		
4PCS	4PCS	4PCS

**Step 25**  
**Étape 25**



<b>A2</b>  4PCS	<b>B1</b>  4PCS
<b>A3</b>  4PCS	

Step 26  
Étape 26

A3



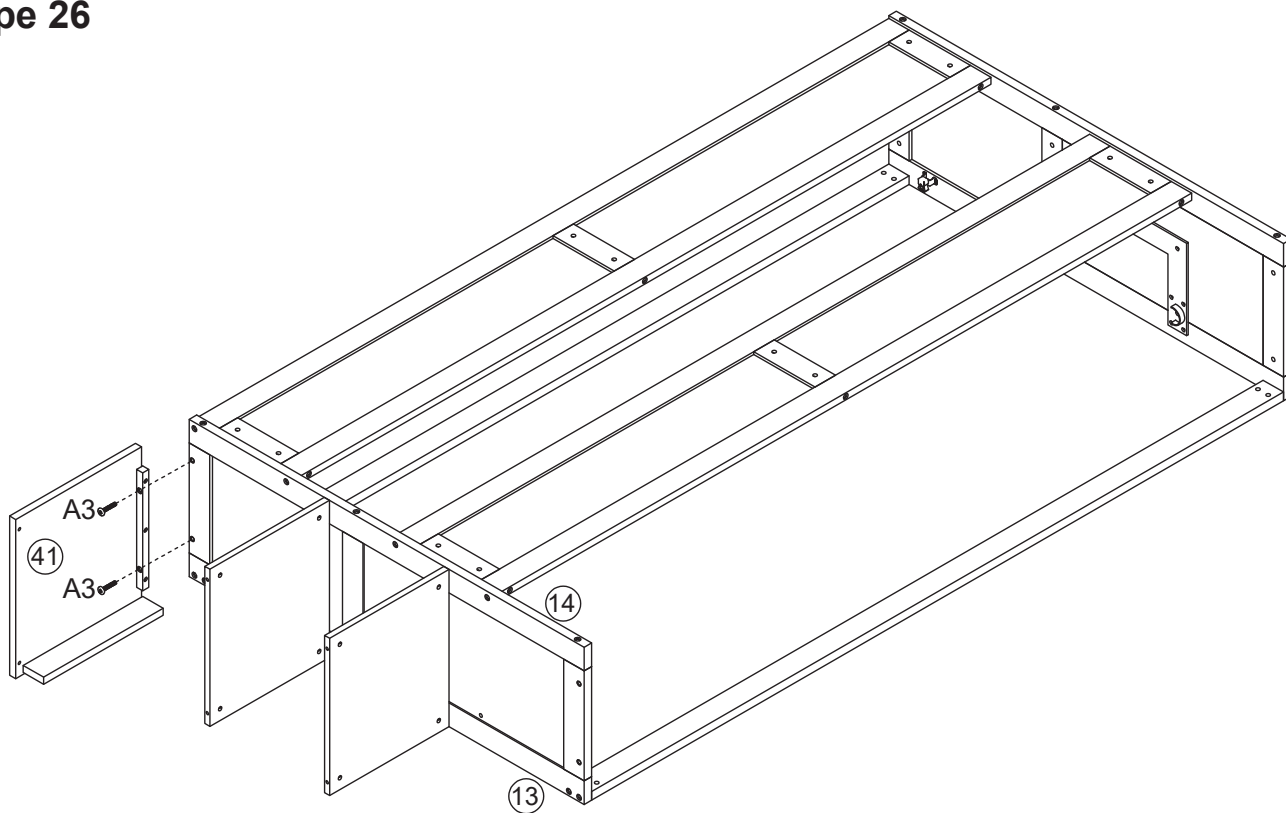

2PCS

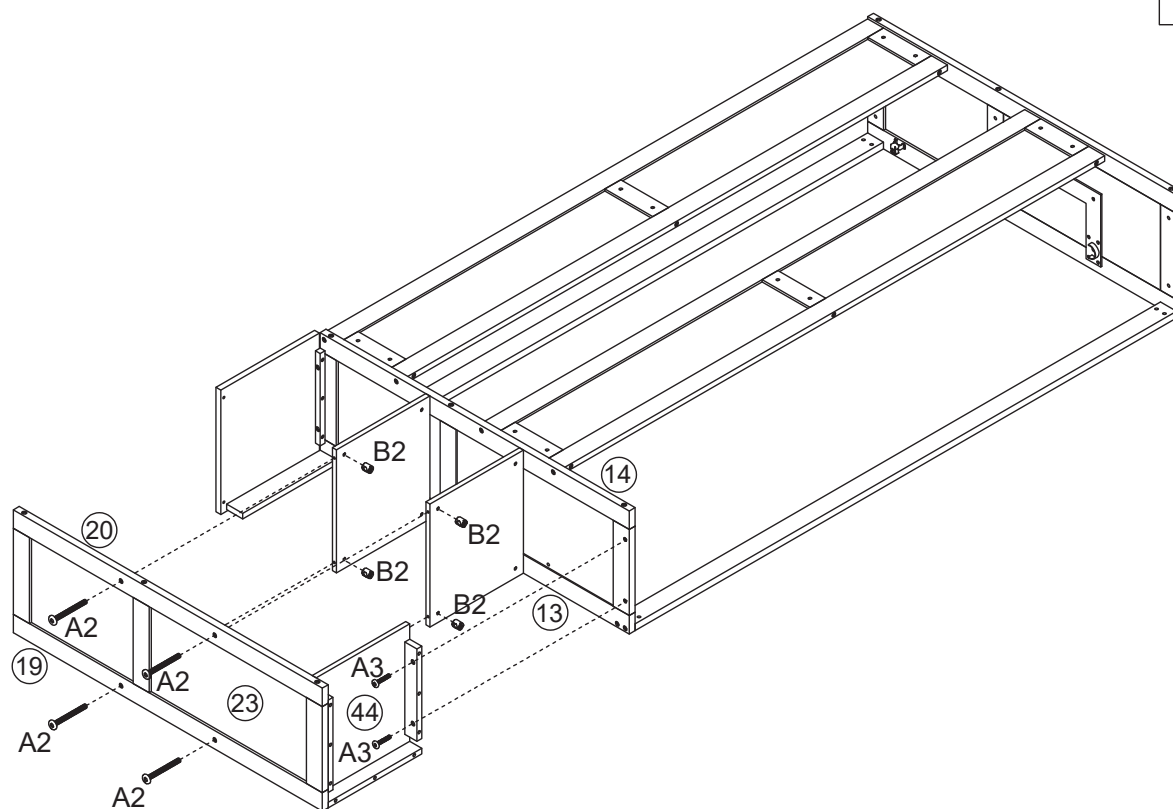

Step 27  
Étape 27



<b>A2</b>  4PCS	<b>B2</b>  4PCS
<b>A3</b>  2PCS	

Step 28  
Étape 28



A3

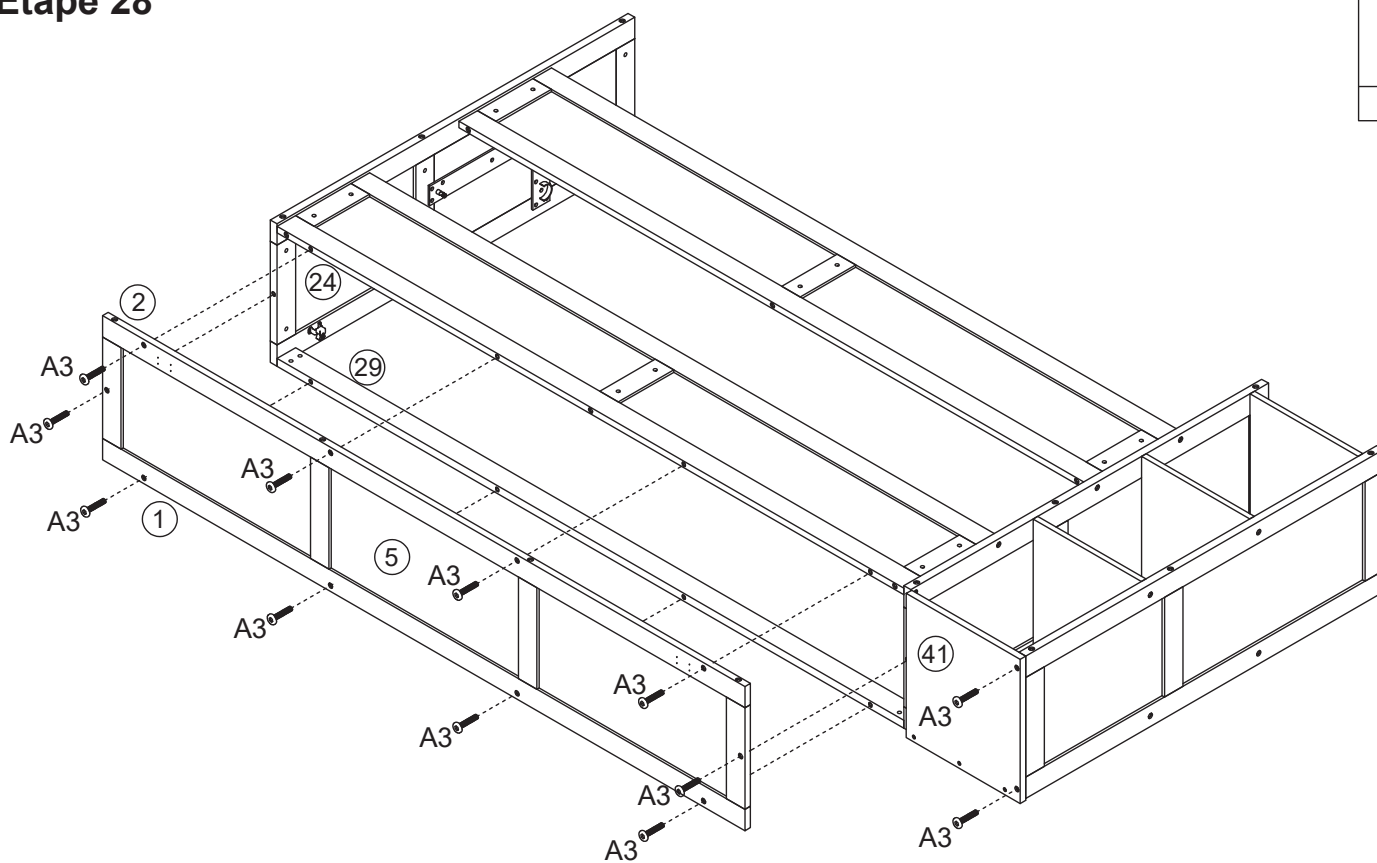

12PCS

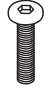

Step 29  
Étape 29

D	E	M
		
1PC	2PCS	2PCS

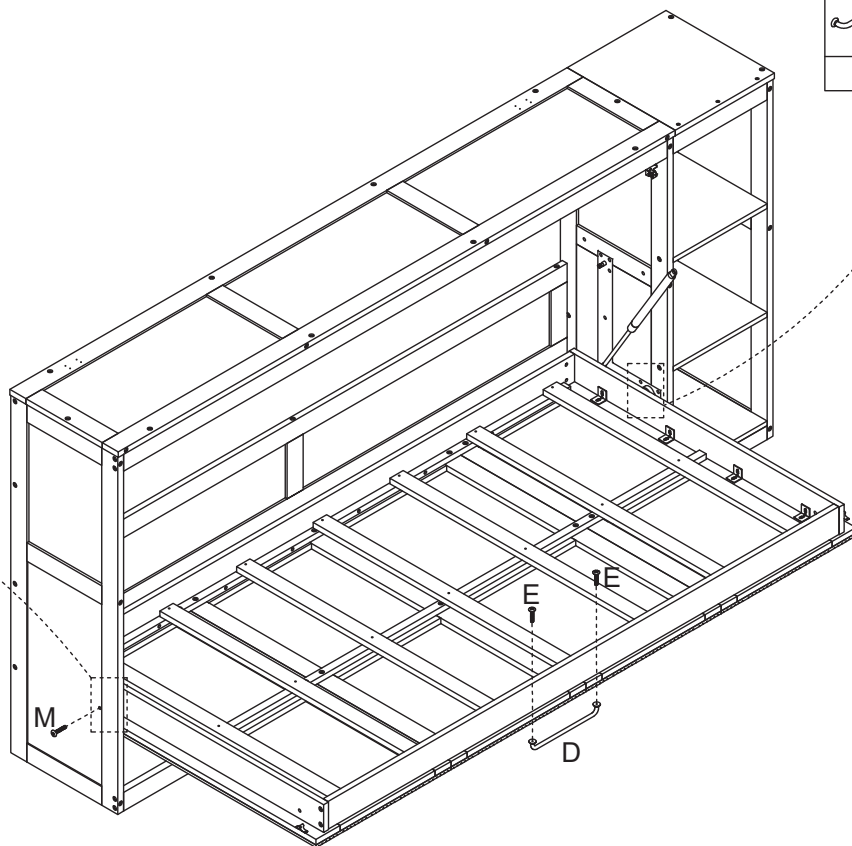
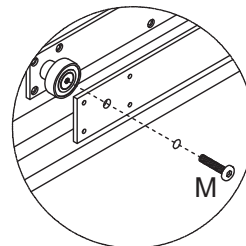
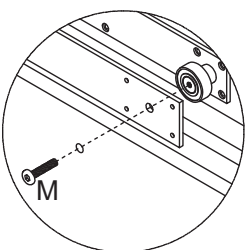
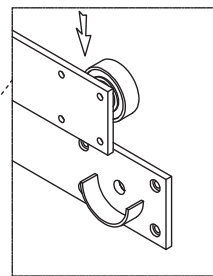
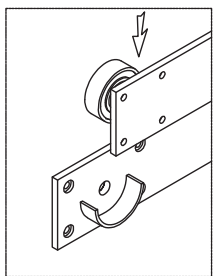

**Step 30**  
**Étape 30**

**G**



1PC

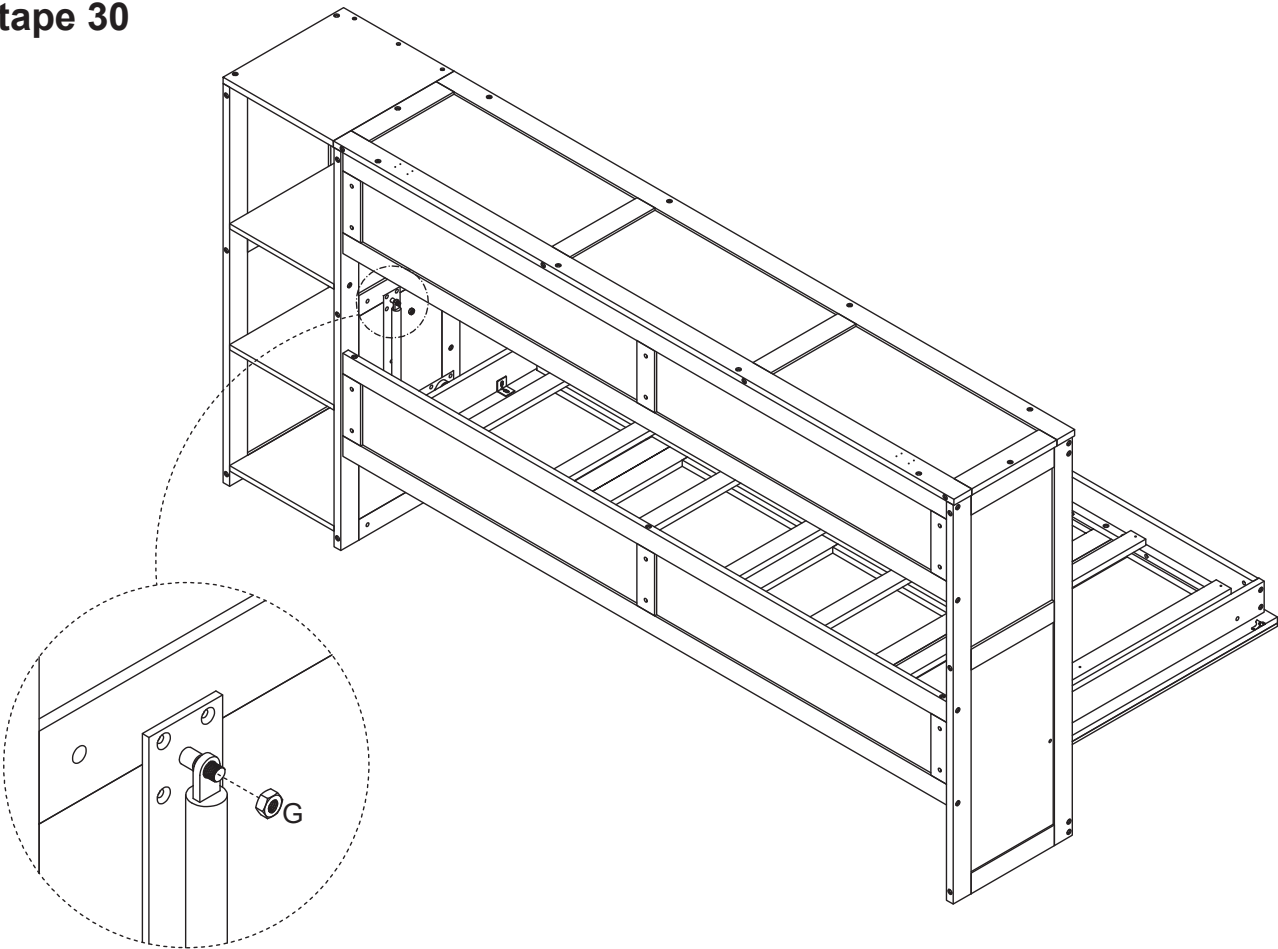

**Step 31**  
**Étape 31**

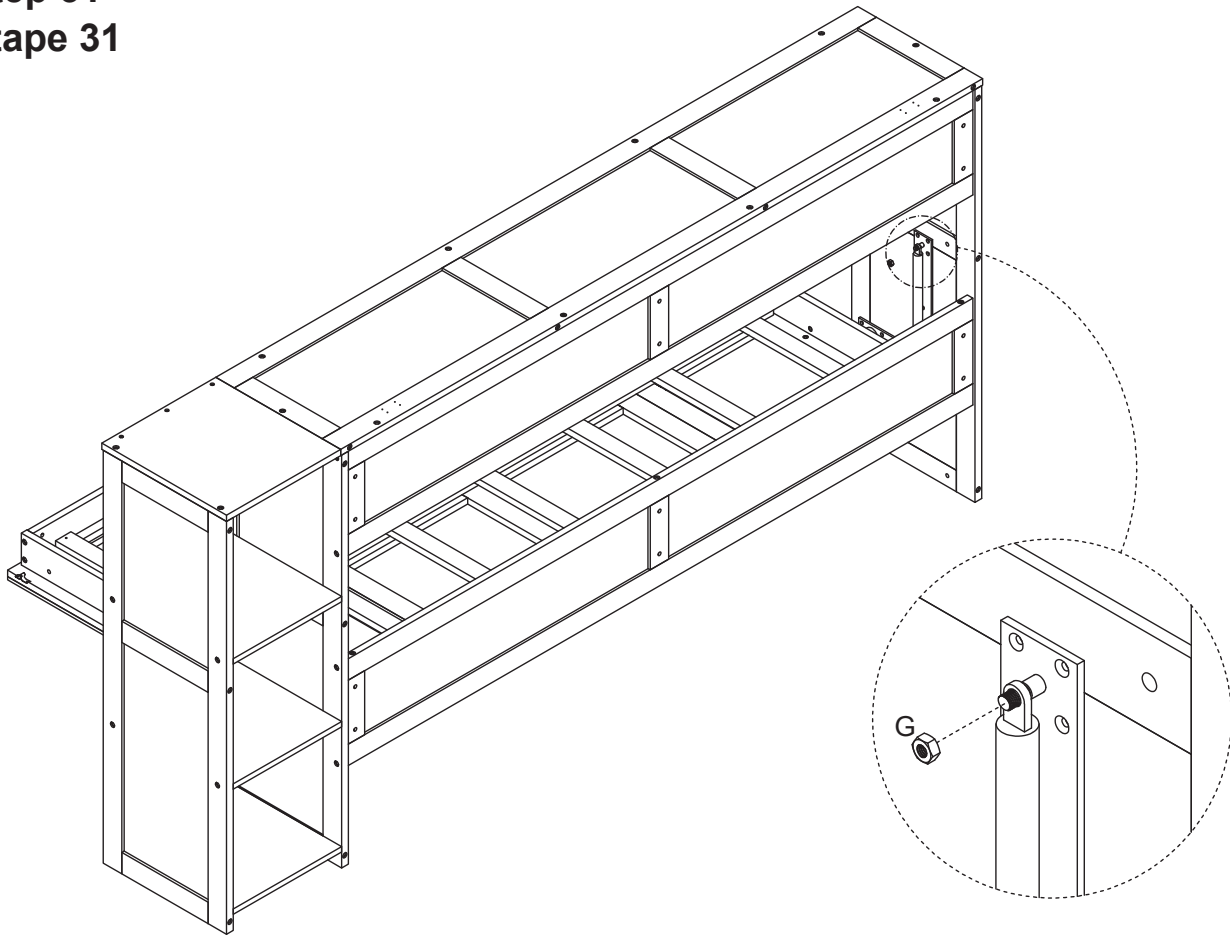





G

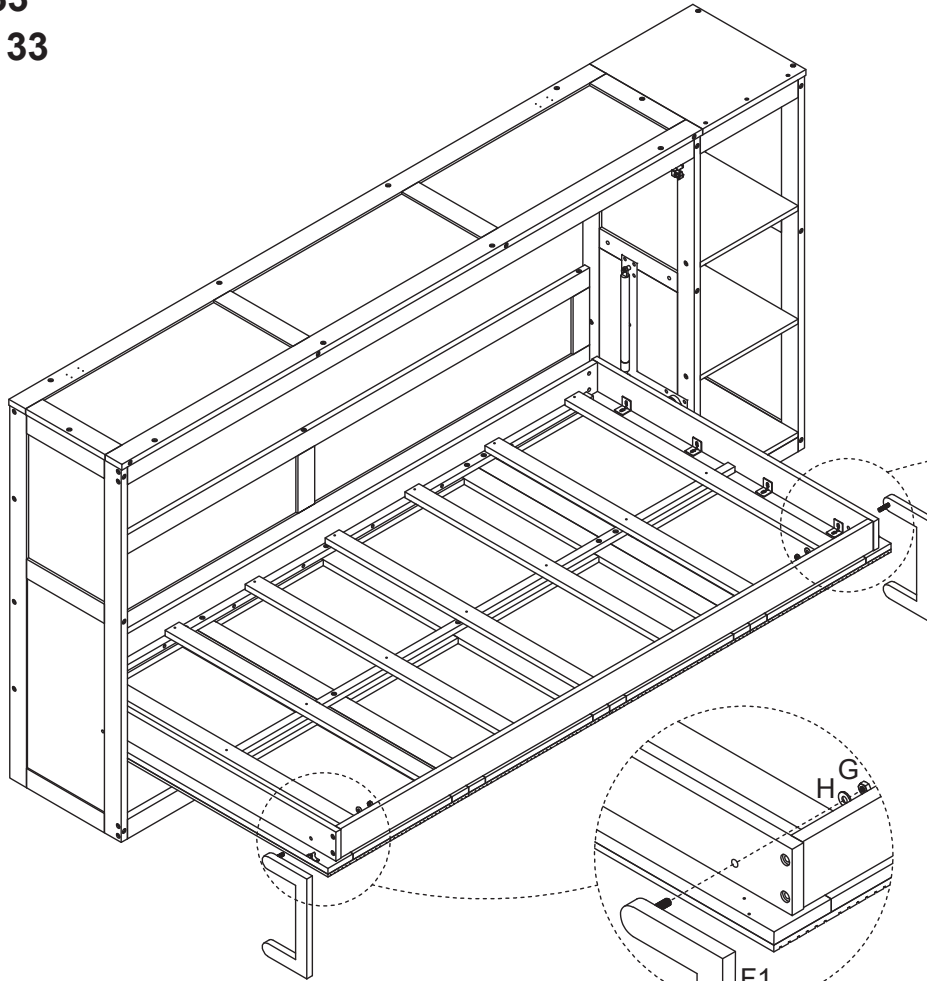

1PC

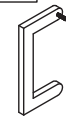
**Step 33**  
**Étape 33**

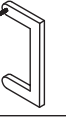

<b>F1</b>  1PC	<b>G</b>  2PCS
<b>F2</b>  1PC	<b>H</b>  2PCS

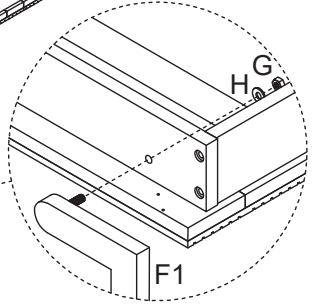
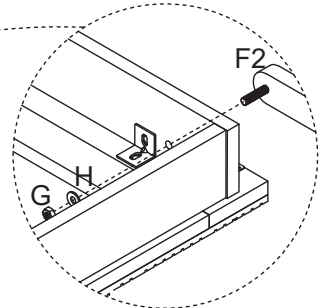

**Step 34**  
**Étape 34**

**OPEN STATE**

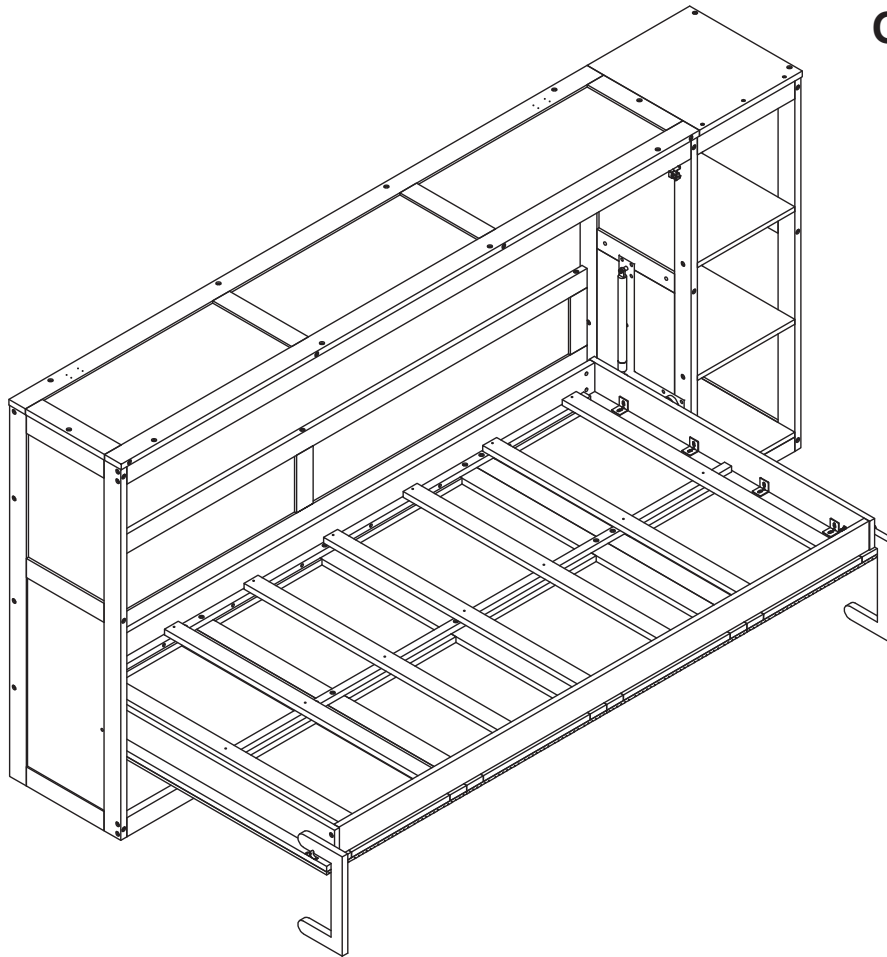

**Step 35**  
**Étape 35**

**CLOSE STATE**

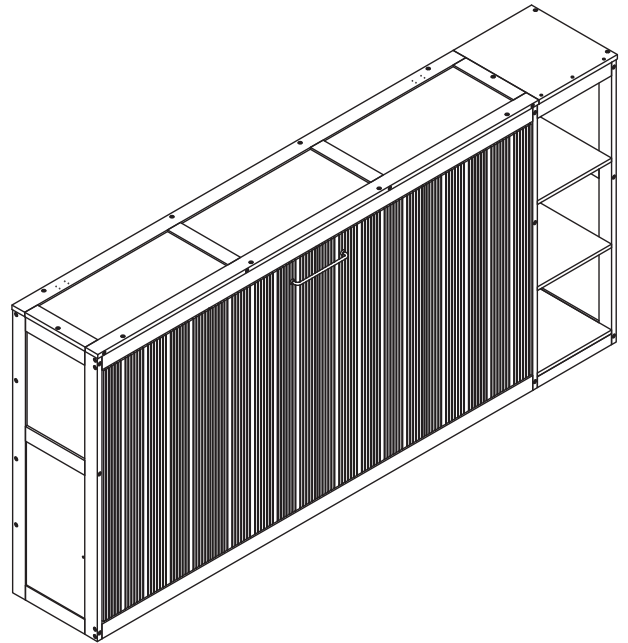
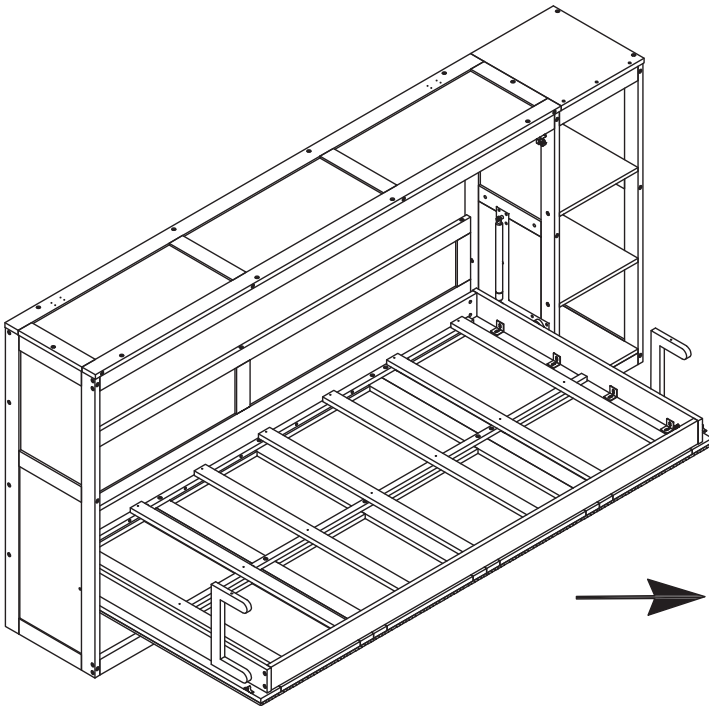

# Step 36

## Étape 36

1- Determine the position of the bed in the room

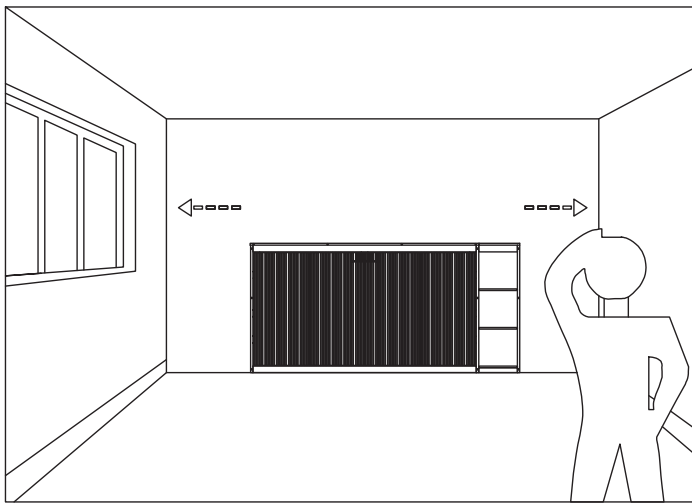

2- Put the bed black in its place. Please keep it vertical and horizontal

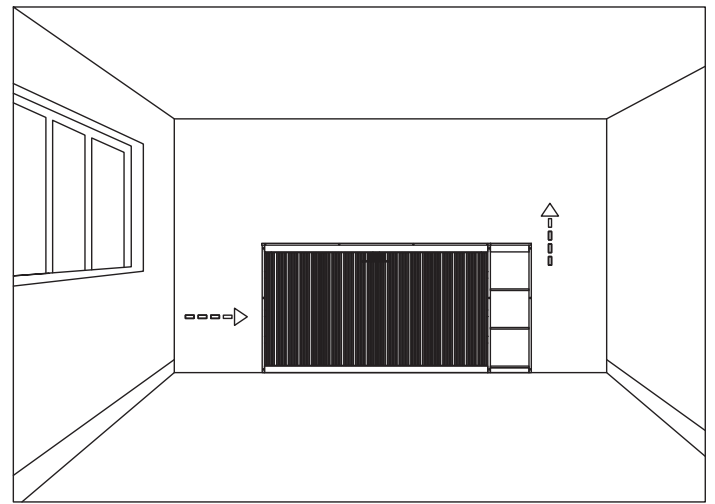

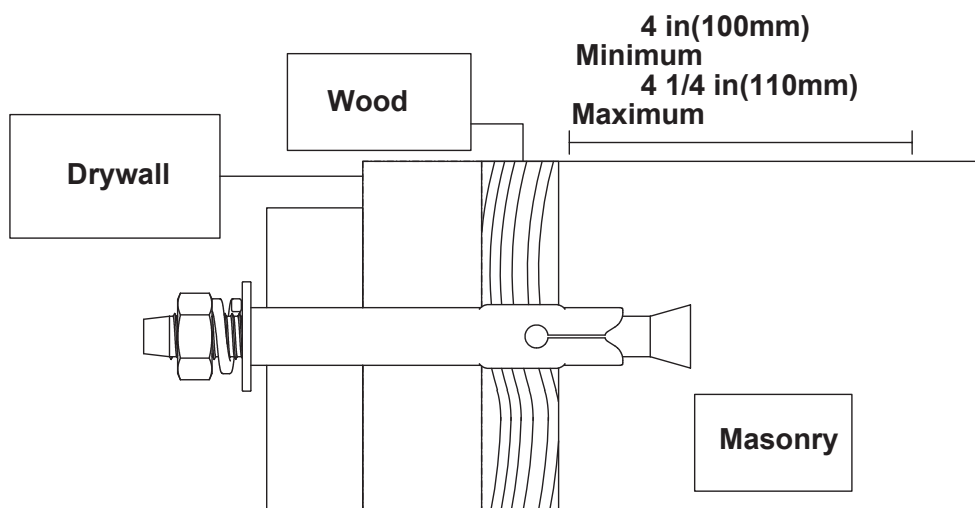

## Step 37 Étape 37

Put the bed back in its place. Put the **CONCRETE SCREWS** 3/8"(10mm) diameter X **APPROPRIATE LENGTH** into the holes of part #2 and screw the bed onto the masonry wall until tight against the wall. Screw must be at least 4"(100mm) deep into masonry. **USE AN ELECTRIC SCREWDRIVER WITH AN ADJUSTABLE TENSION CLUTCH THAT HELPS PREVENT OVER-TIGHTENING AND STRIPPING.**



**Step 38**  
**Étape 38**

<b>P</b>		<b>O2</b>	
4SETS		2PCS	

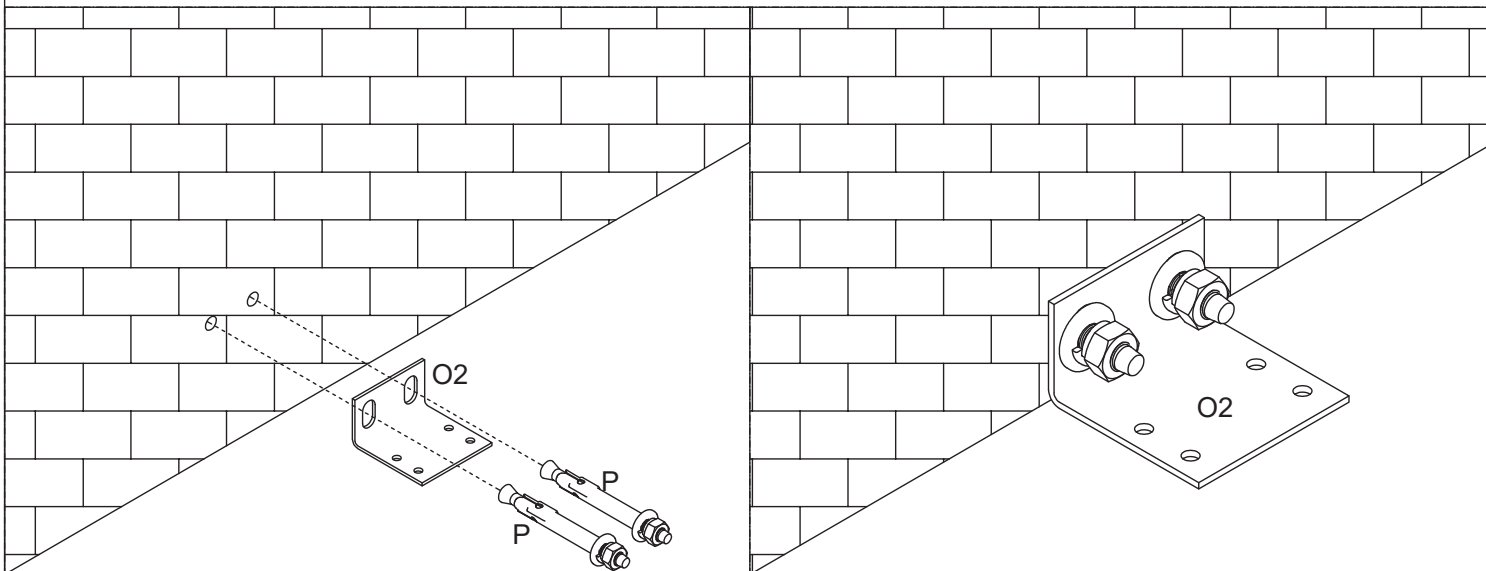

**Step 39**  
**Étape 39**

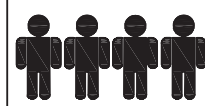

Requires 4 people to assemble  
(2 people hold the large cabinet  
in place and 2 people tilt the bed  
until accessories are in place)

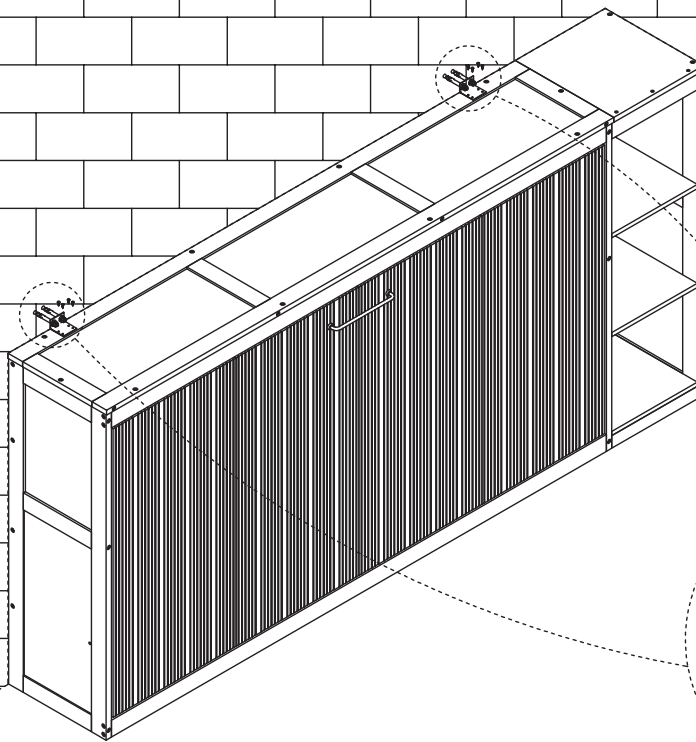

Q



8PCS

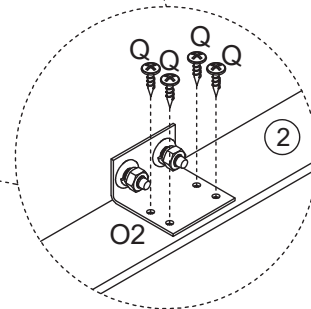

**Step 40**  
**Étape 40**

