

ASSEMBLY INSTRUCTION

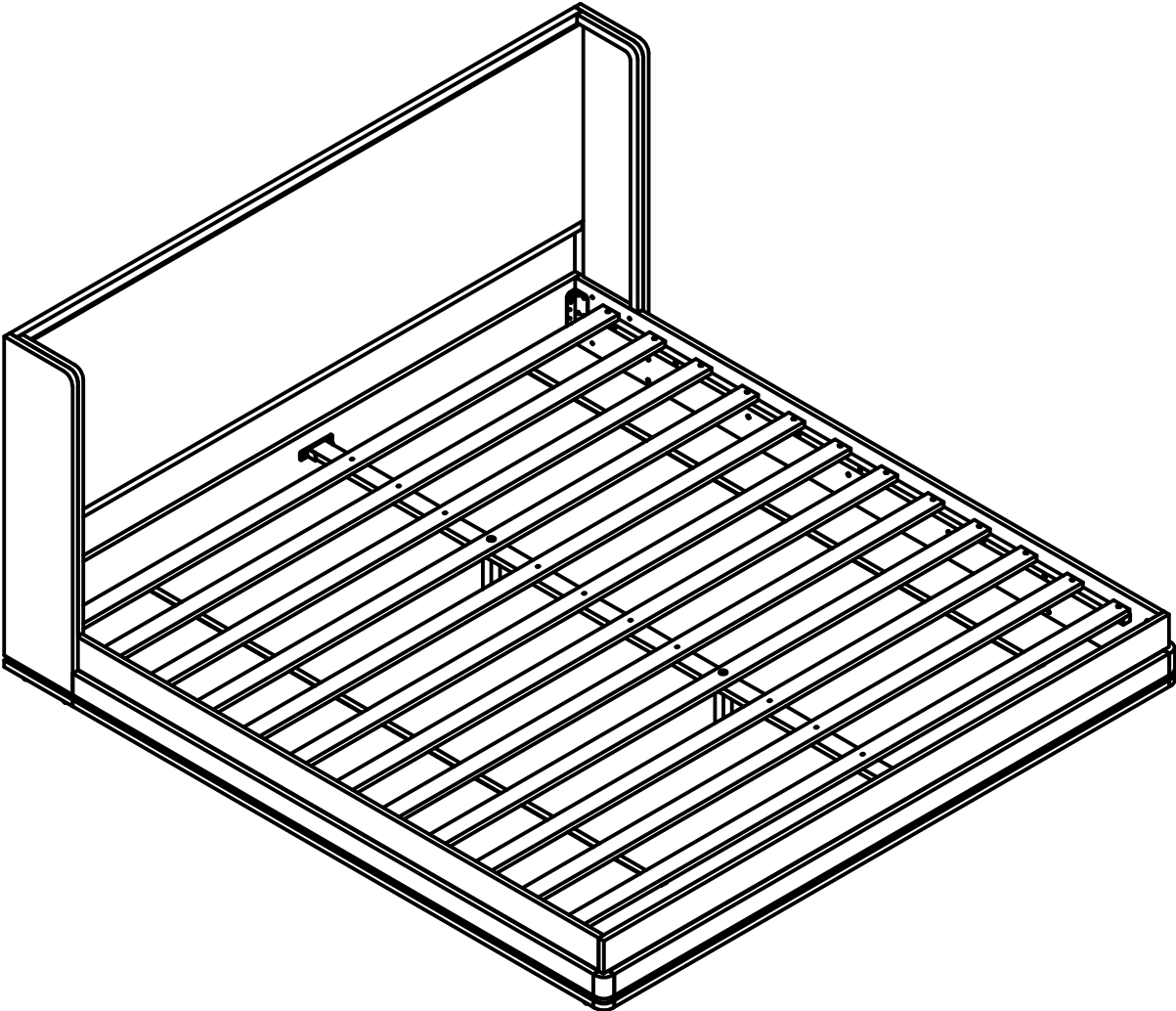

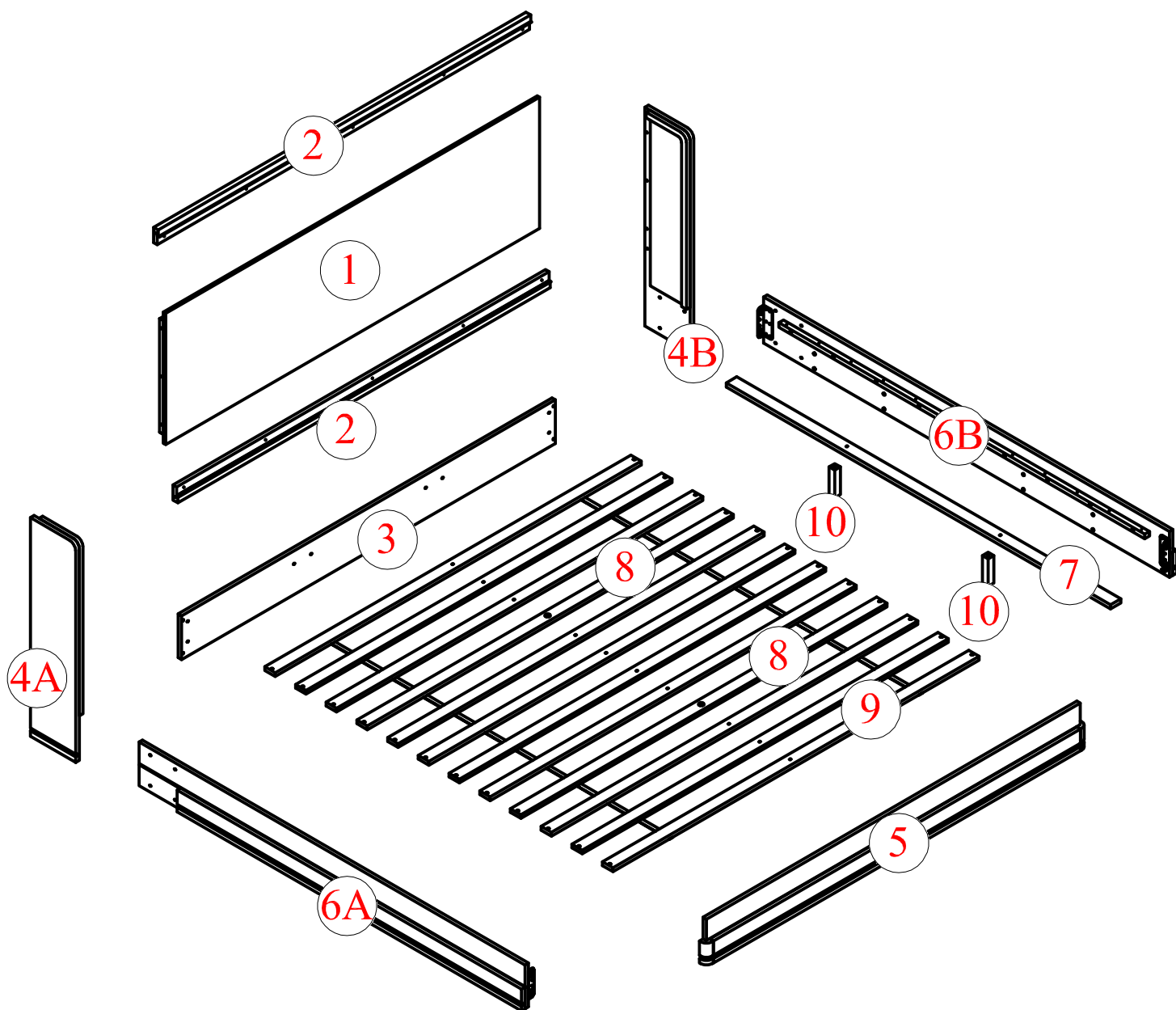



ASSEMBLY INSTRUCTION

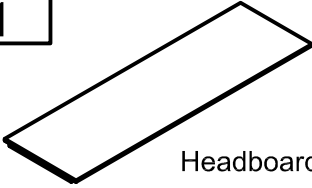
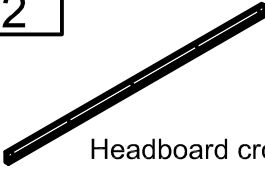
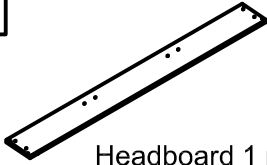
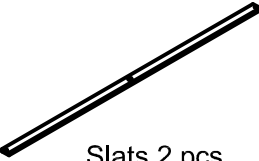
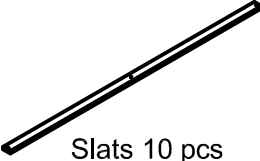



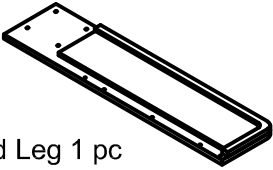
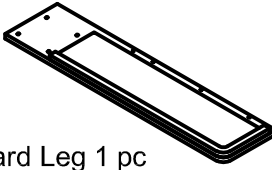
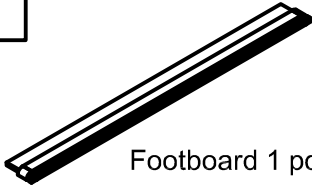
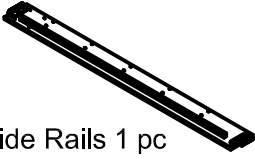

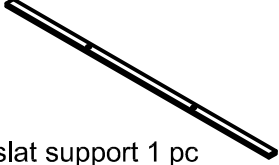



Part List

1  Headboard 1 pc	2  Headboard cross bar 2 pcs	3  Headboard 1 pc
8  Slats 2 pcs	9  Slats 10 pcs	

Part List

4A  Headboard Leg 1 pc	4B  Headboard Leg 1 pc	5  Footboard 1 pc
6A  Side Rails 1 pc	6B  Side Rails 1 pc	7  Bed slat support 1 pc
	10  Extra Legs 2 pcs	

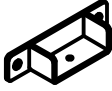
Hardware List

A  Ø8 x 30 mm Wood dowel 4 (+1) pcs	B  1/4" x 35 mm Hex-Head bolts 6 (+1) pcs	C  Allen Wrench 1 (+1) pc
D  1/4" x 20 mm Hex-Head bolts 12 (+1) pcs	E  1/4" x 50mm Hex-Head bolts 2 (+1) pcs	F  M4 x 15 mm Wood Screws 2 (+1) pcs
G  Steel Bracket 2 pcs	H  M4 x 30 mm Wood Screws 44 (+1) pcs	I  1/4" x 30 mm Hex-Head bolts 8 (+1) pcs

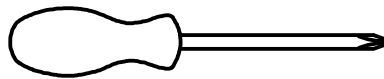



Assembly Tools Required (Not Included)

STEP 1: Following below illustration:

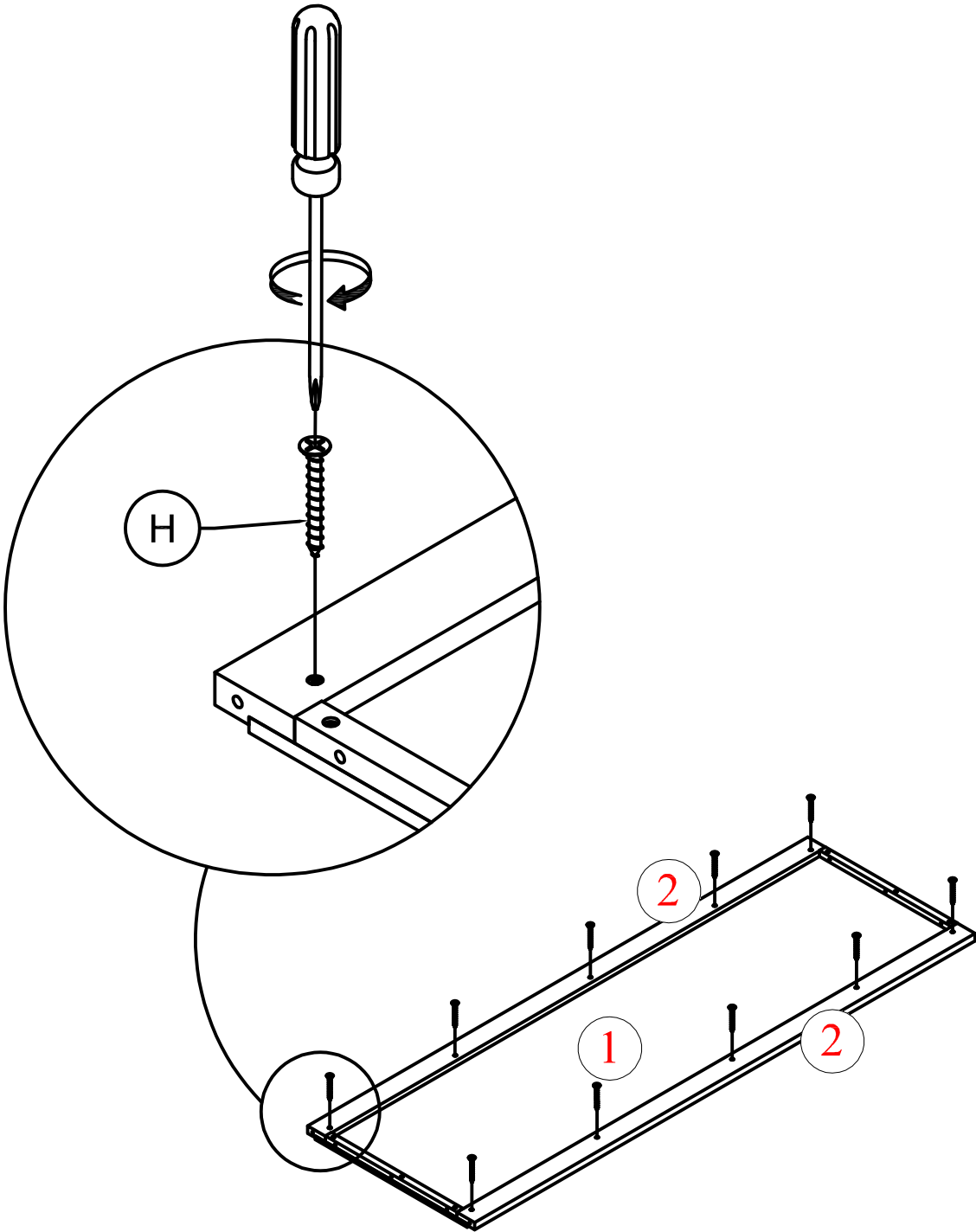
H	
10pcs	



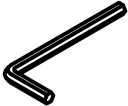

STEP 2: Following below illustration:

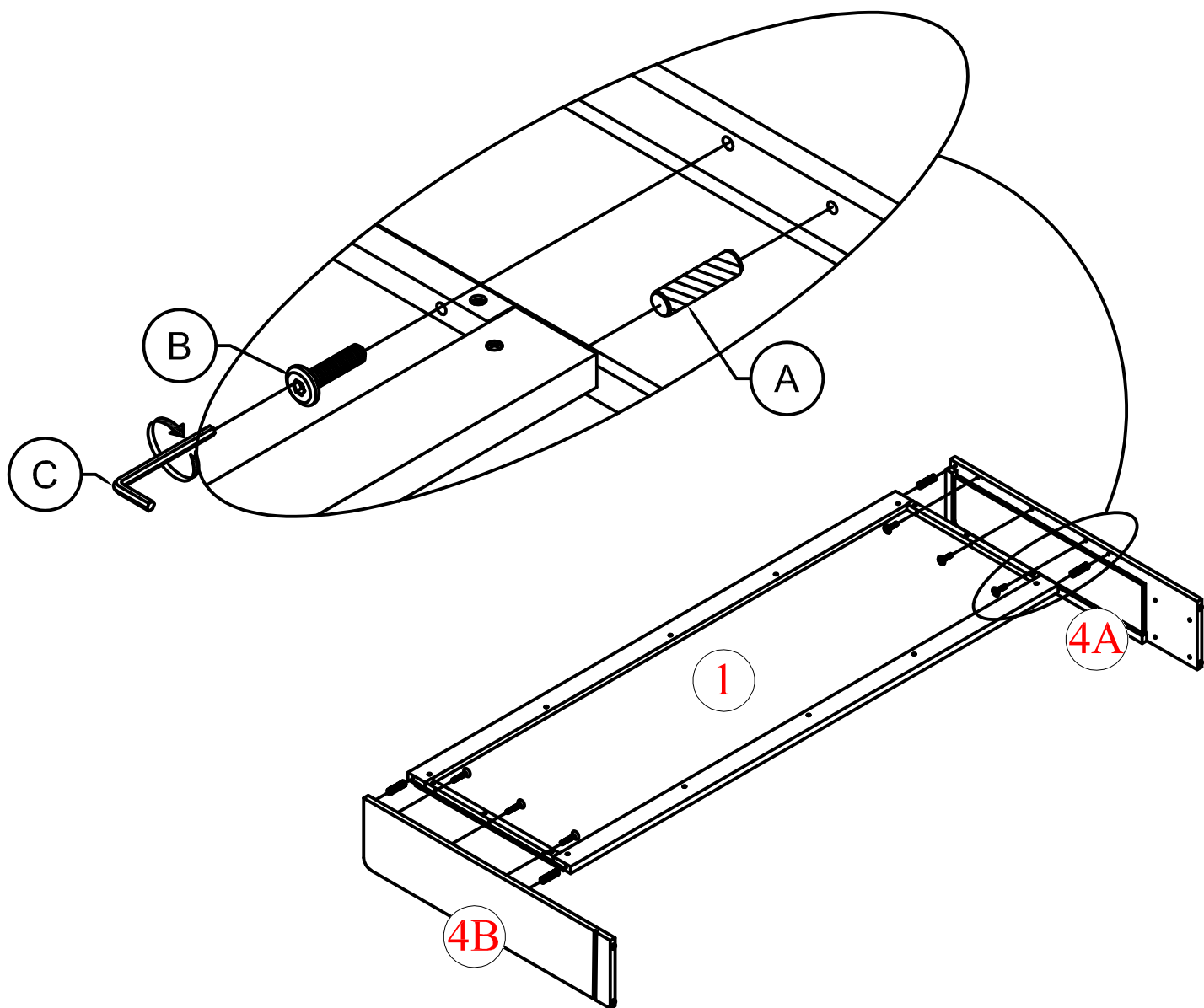
A	B	C
		
4pcs	6pcs	1pc



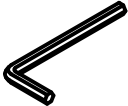

STEP 3: Following below illustration:

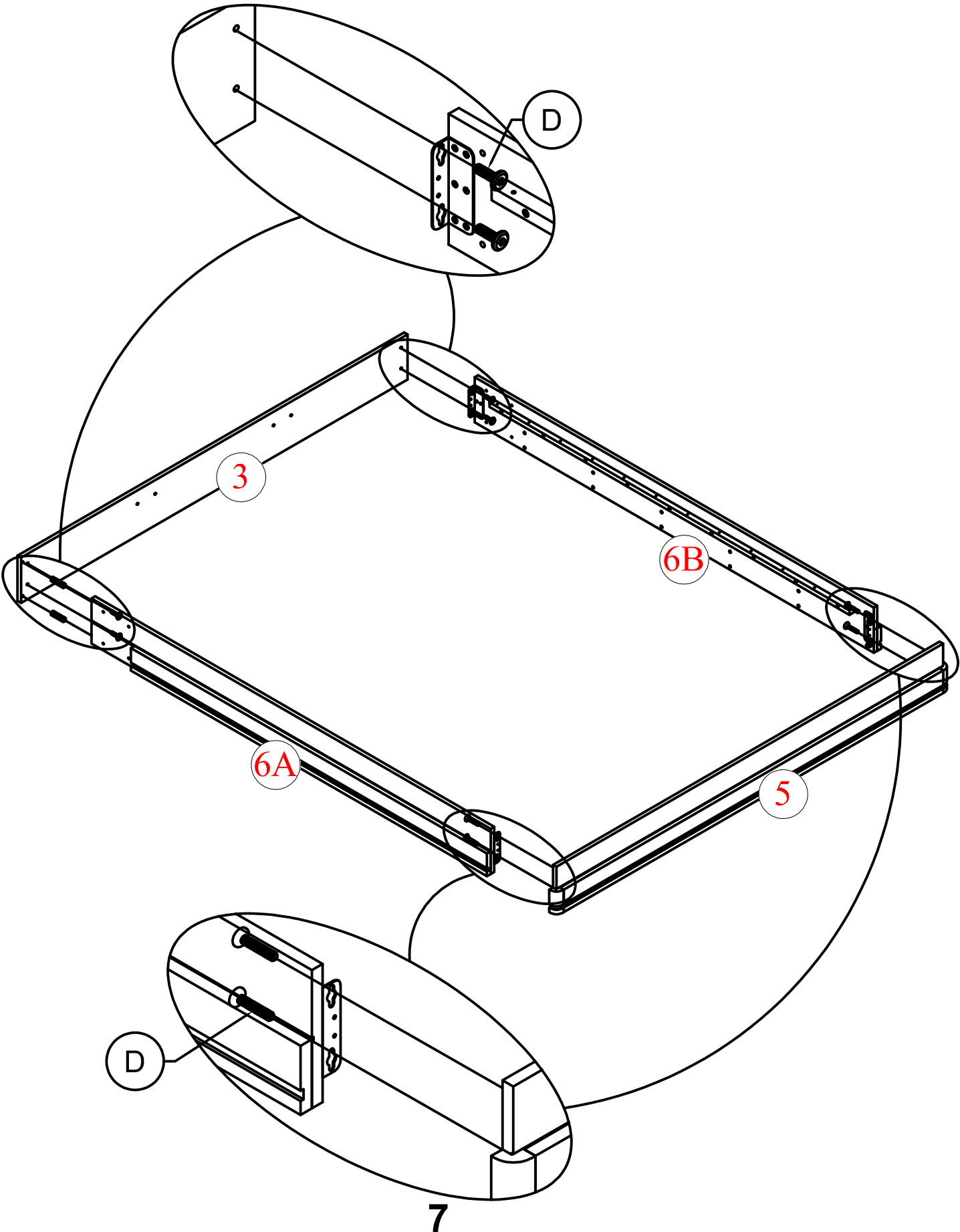
C	D
	
1pc	8pcs



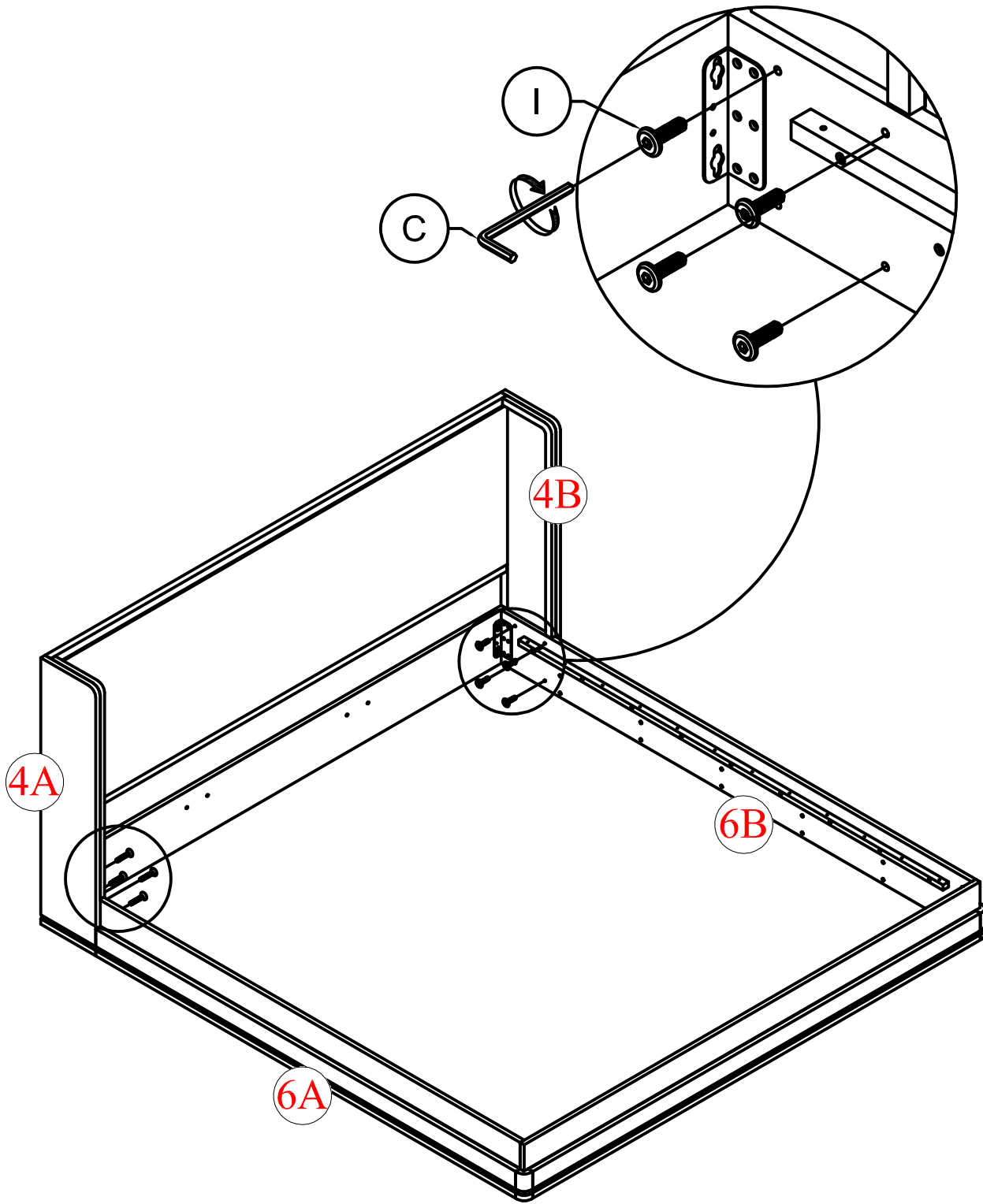

STEP 4: Following below illustration:

C	I
	
1pc	8pcs



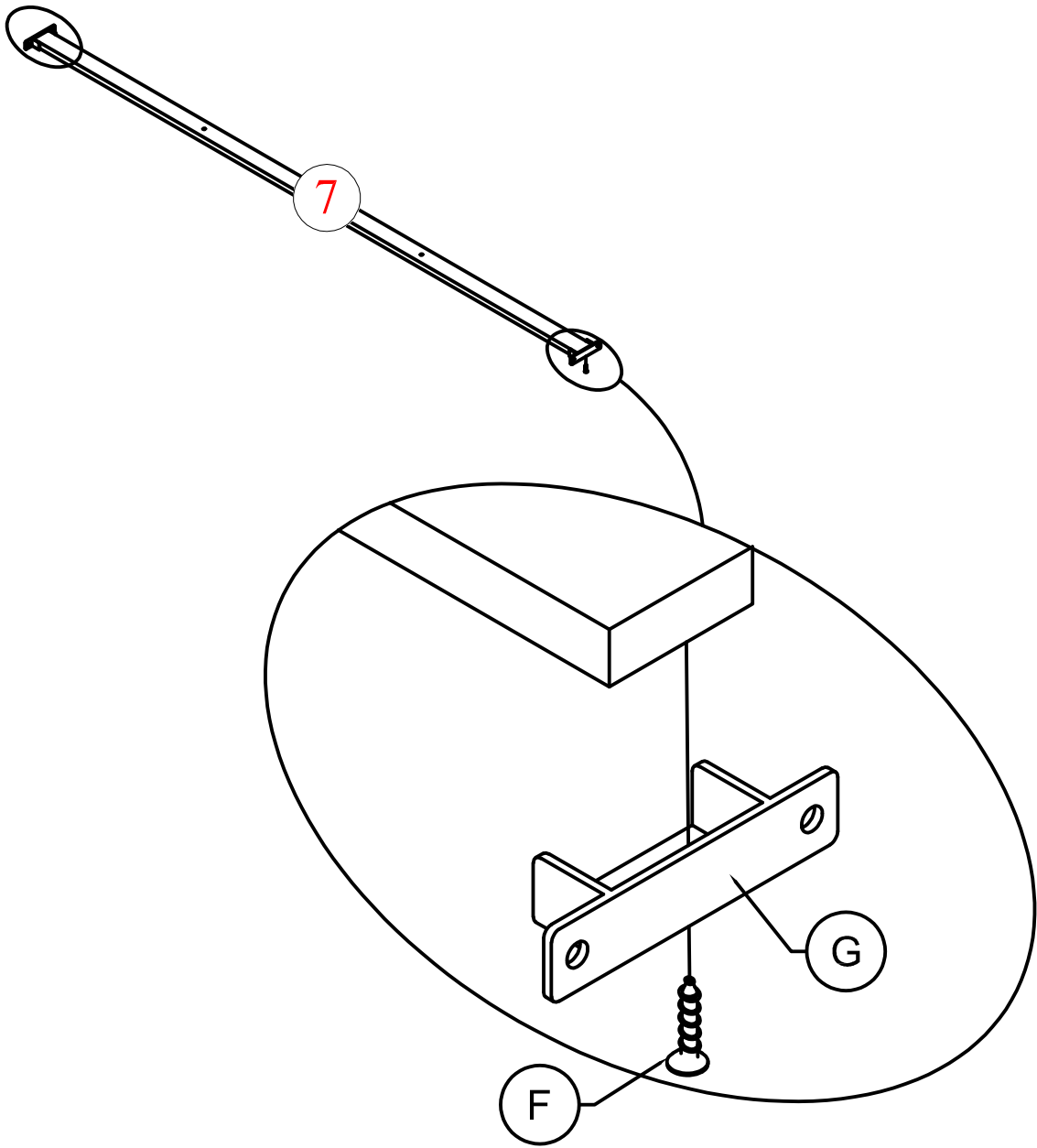

STEP 5: Following below illustration:

G	F
	
2pcs	2pcs



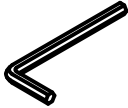

STEP 6: Following below illustration:

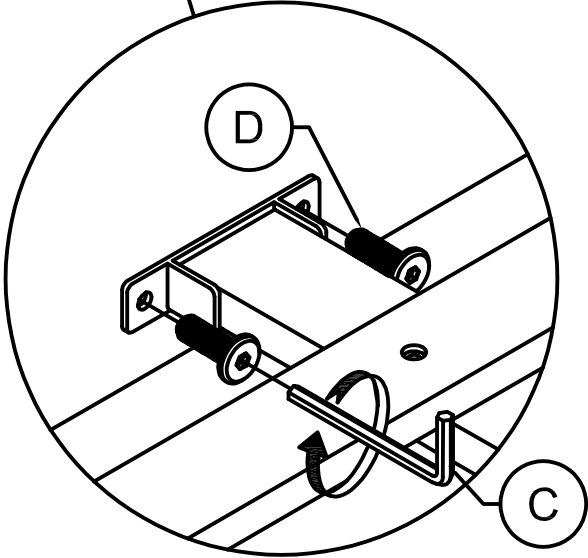
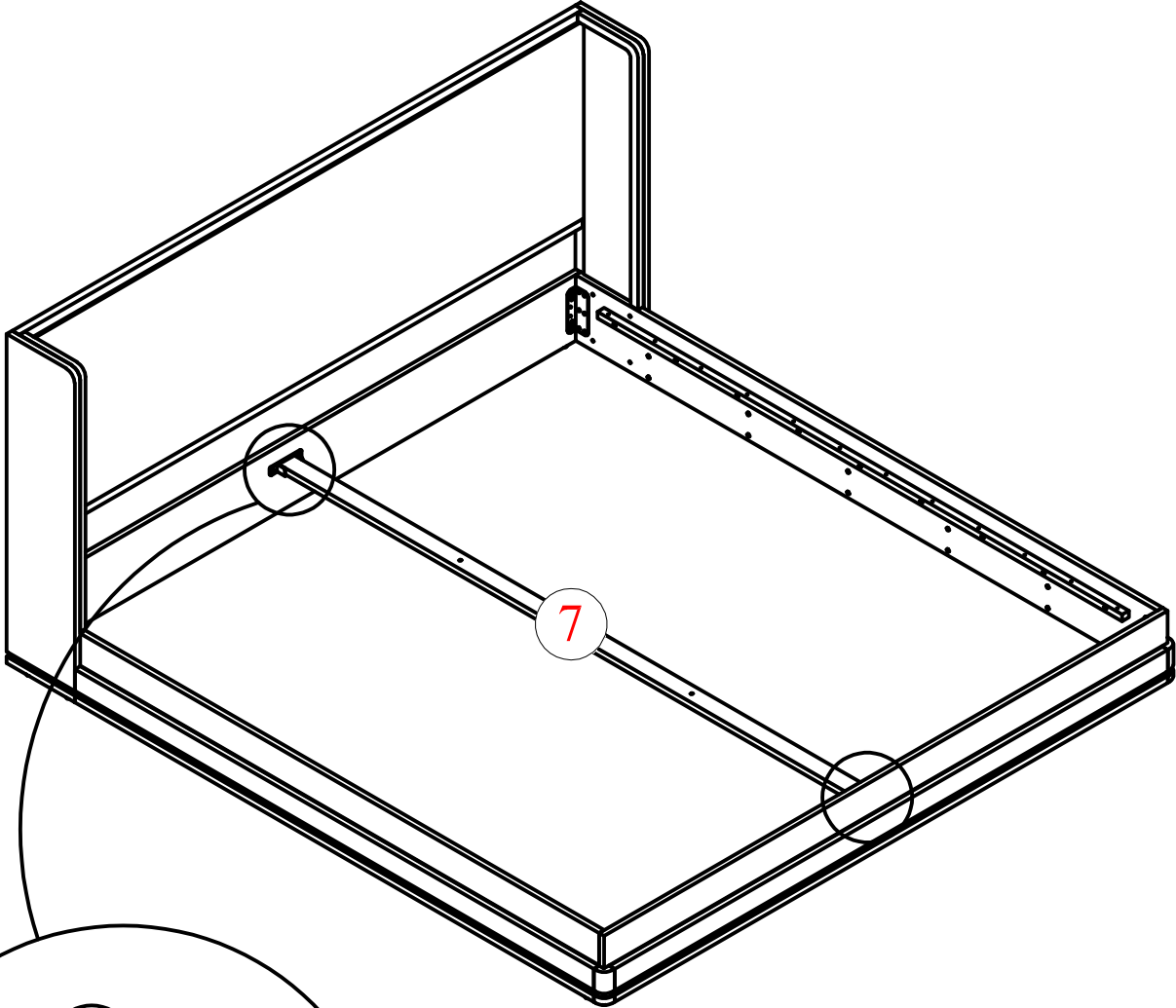
C	D
	
1pc	4pcs

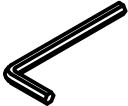

STEP 7: Following below illustration:

C	E
	
1pc	2pcs

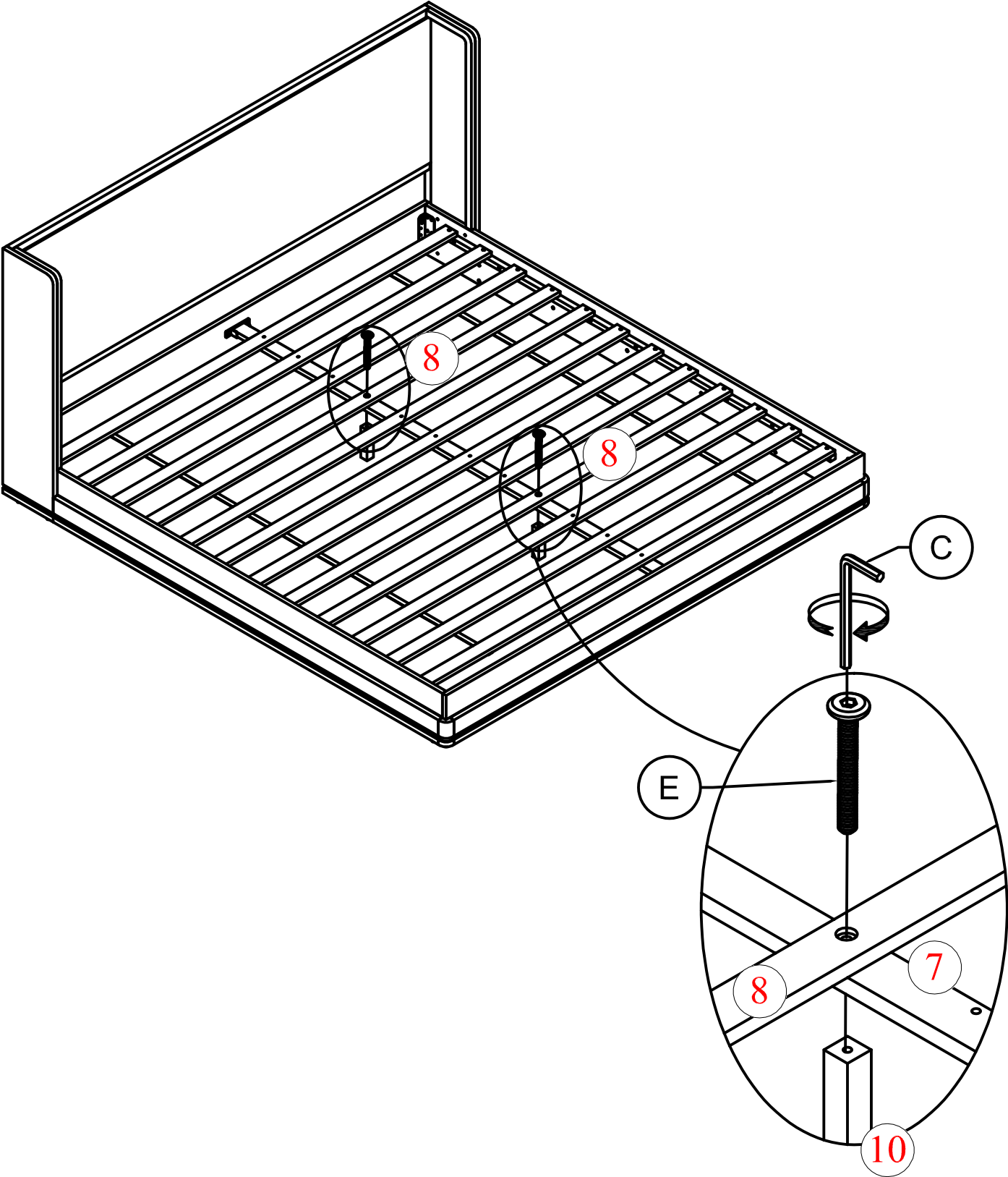

STEP 8: Following below illustration:

H	
34pcs	

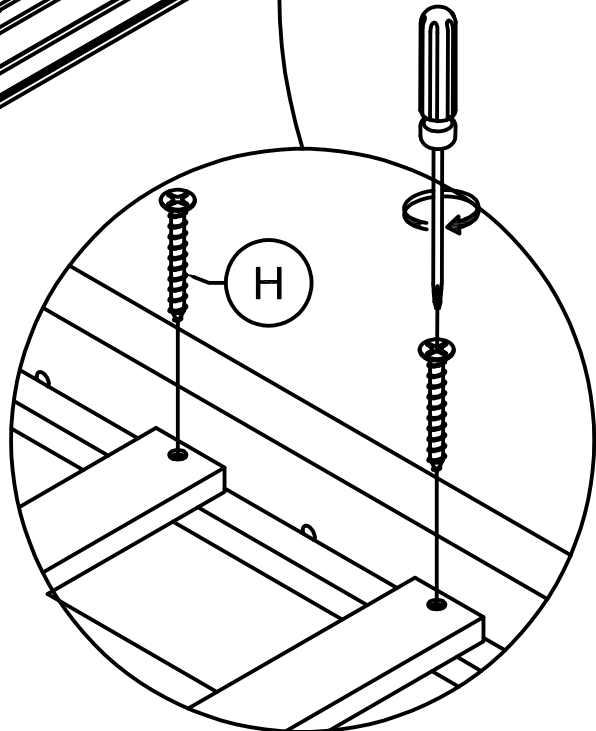
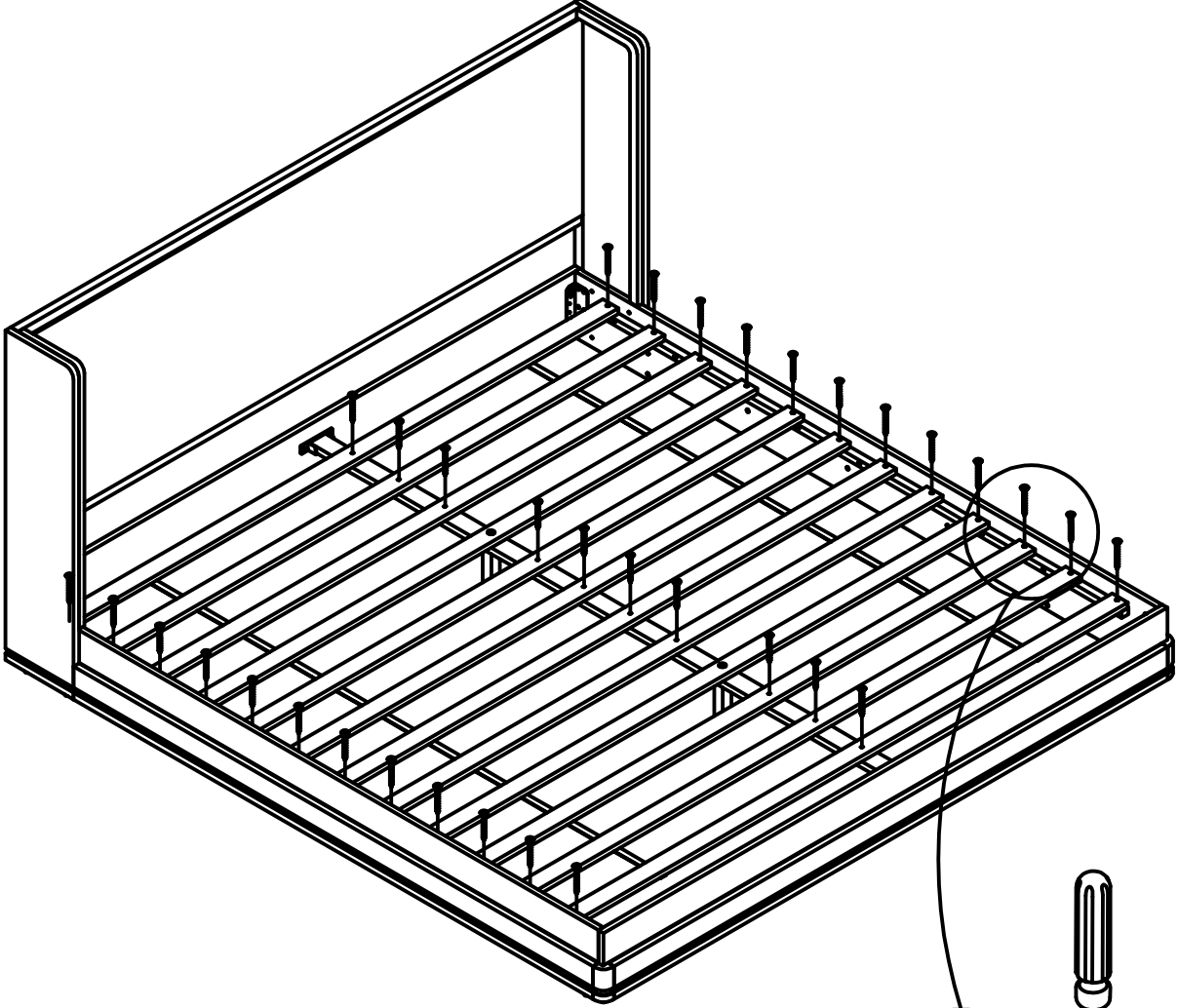

FINISH

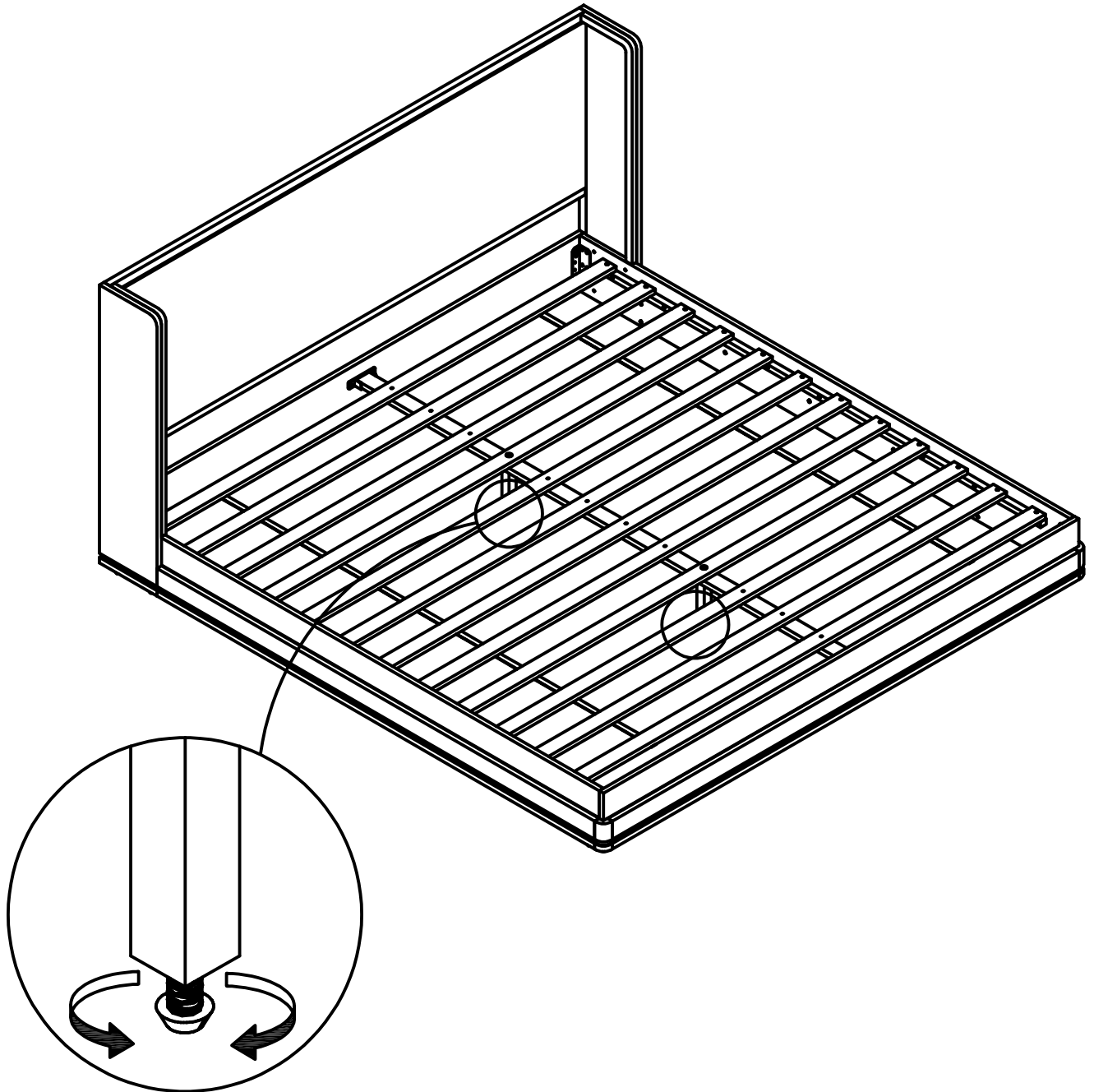

Rotate counterclockwise to increase the length of Floor Leveler, and raise that corner. Rotate clockwise to lower that corner.

Make sure to tighten all the screws of the bed.