

ASSEMBLY INSTRUCTIONS

WF 313007
DINING TABLE

IMPORTANT NOTES :

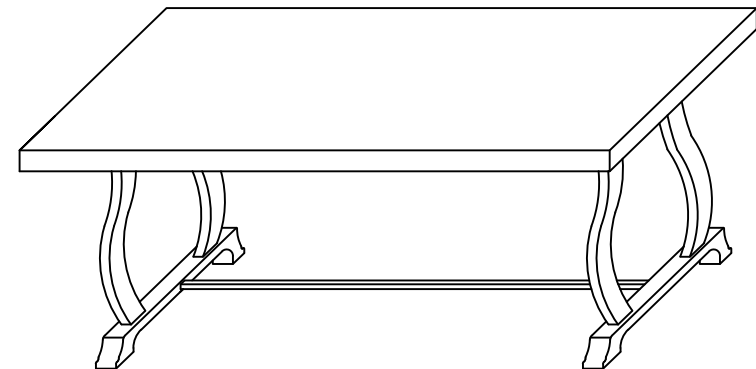



1. PLACE ALL PARTS ON A CLEAN AND SMOOTH SURFACE SUCH AS A RUG OR CARPET TO AVOID THE PARTS FROM BEING SCRATCHED
2. BEFORE YOU START , KINDLY FOLLOW THE ASSEMBLY INSTRUCTION STEP BY STEP.



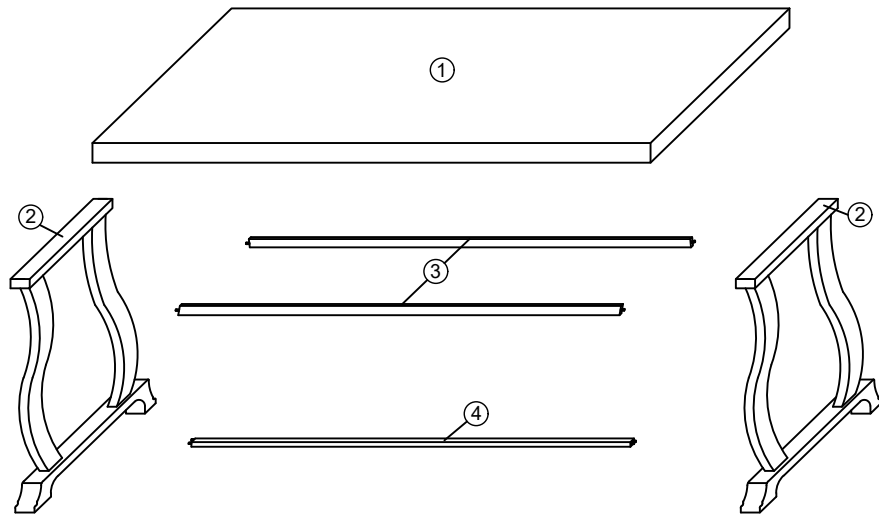







ASSEMBLY INSTRUCTIONS

WF 313007



PARTS LIST		
NO.	COMPONENT	QTY.
1	TABLE TOP 	1 PC
2	TABLE LEGS 	2 PCS
3	TABLE FRAME 	2 PCS
4	TABLE LEGS SUPPORT 	1 PC

HARDWARE LIST			
NO.	COMPONENT		QTY.
A	JCBC M6 X 60MM		4 PCS
B	JCBB M8 X 30MM		6 PCS
C	JCBB M8 X 60MM		2 PCS
D	CSK SCREW M4 X 32MM		8 PCS
E	M4 ALLEN KEY		1 PC
F	M5 ALLEN KEY		1 PC
G	M8 X 30MM WOOD DOWEL		4 PCS
H	M10 X 30MM WOOD DOWEL		4 PCS

ASSEMBLY INSTRUCTIONS

WF 313007

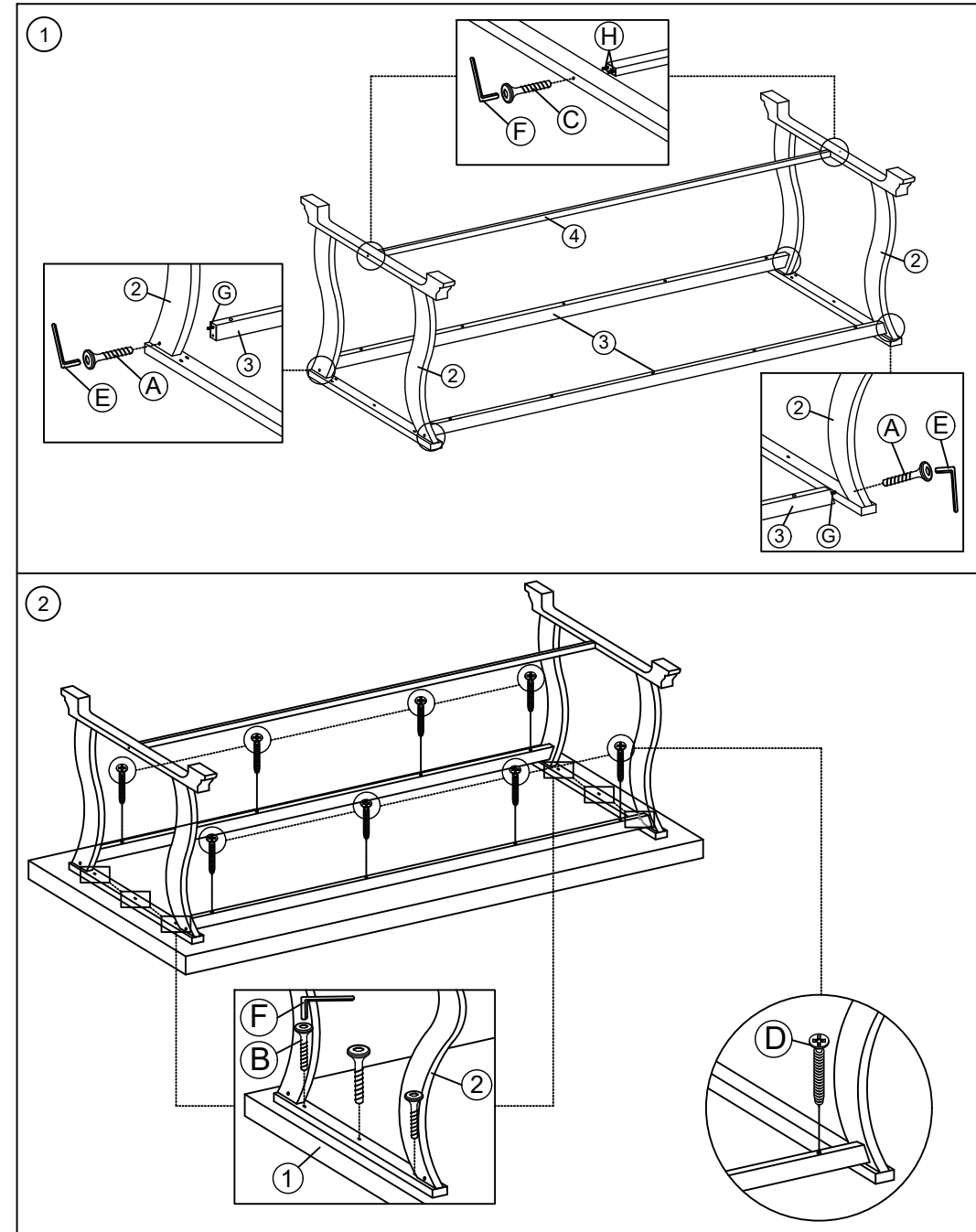

ASSEMBLY INSTRUCTIONS

WF 313008
CHAIR + BENCH

IMPORTANT NOTES :

1. PLACE ALL PARTS ON A CLEAN AND SMOOTH SURFACE SUCH AS A RUG OR CARPET TO AVOID THE PARTS FROM BEING SCRATCHED
2. BEFORE YOU START, KINDLY FOLLOW THE ASSEMBLY INSTRUCTION STEP BY STEP.

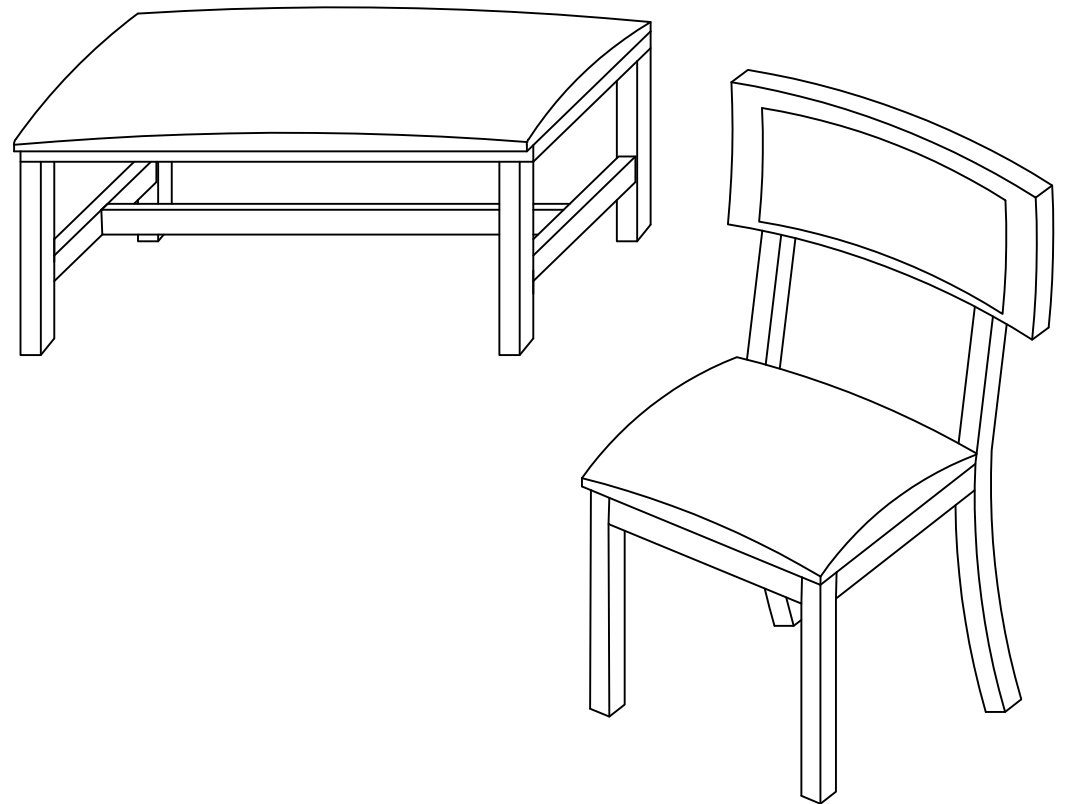

ASSEMBLY INSTRUCTIONS

WF 313008

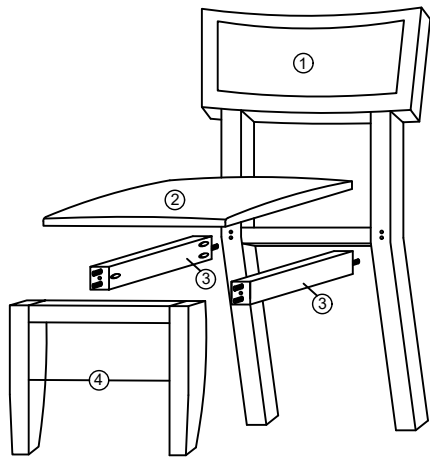

PARTS LIST FOR ONE		
NO.	COMPONENT	QTY.
1	CHAIR BACK	1 PC
2	CUSHION SEAT	1 PC
3	SIDE RAIL	2 PCS
4	FRONT LEG WITH APRON	1 PC

HARDWARE LIST FOR ONE		
NO.	COMPONENT	QTY.
A	JCBC M6 X 50MM	6 PCS
B	CSK SCREW M4 X 32MM	3 PCS
C	SPRING WASHER	6 PCS
D	M4 ALLEN KEY	1 PC
E	M8 X 30MM WOOD DOWEL	6 PCS

ASSEMBLY INSTRUCTIONS

WF 313008

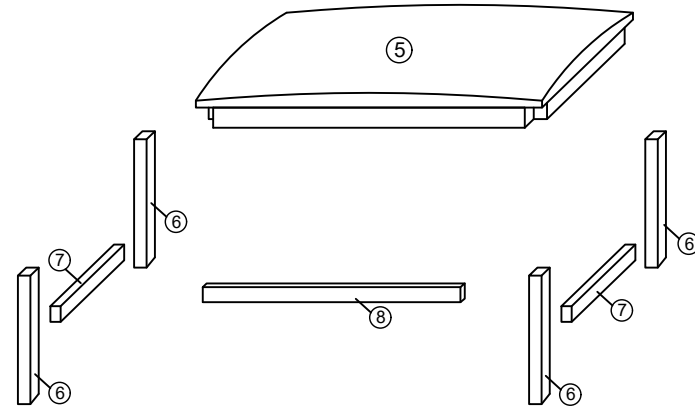

PARTS LIST FOR ONE		
NO.	COMPONENT	QTY.
5	CUSHION SEAT W APRON	1 PC
6	BENCH LEGS	4 PCS
7	BENCH LEGS SUPPORT	2 PCS
8	BENCH CENTER SUPPORT	1 PC

HARDWARE LIST FOR ONE		
NO.	COMPONENT	QTY.
A	JCBC M6 X 60MM	8 PCS
B	CSK SCREW M4 X 32MM	6 PCS
C	SPRING WASHER	8 PCS
D	FLAT WASHER	8 PCS
E	M4 ALLEN KEY	1 PC

