

Name: Mos - 01

Design: Joana Bover / 2008

Typology: Pendant lamp









Environment: Indoor

Technical description:

Pendant lamp releasing diffused light through a translucent shade of hand wrapped polyester blend ribbon. Light passes through a white opal glass diffuser, with white, cream or red translucent, hand wrapped polyester blend ribbon options for the shade. The iron structure has a satin nickel finish, available with a transparent PVC wire connection, as well as adjustable or safety tensor wires. Various tensor wires are available. Larger formats are available.



Lamps description

	Grounding: compulsory
	3 x 60 W E26 A15 INC
	3 x 5 W E26 A15 LED
	3 x 14 W E26 Triple CFL
Voltage: 120V~60Hz	
	1 Box 23.62 x 23.62 x 19.69 inches
Vol.: 6.3566 ft ³	
Weight: 17.64 lbs	
Certifications:  	
	Photometrics made according to the position the lights are shown in the catalogue and price list.

Ref Finishings

224P617U	White Translucent Ribbon
224P618U	Cream Translucent Ribbon
224P619U	Red Translucent Ribbon
White opal glass diffuser included	
Satin nickel	
Transparent connection	
Adjustable tensor wire	
Safety tensor wire	
Customizable	

Measures

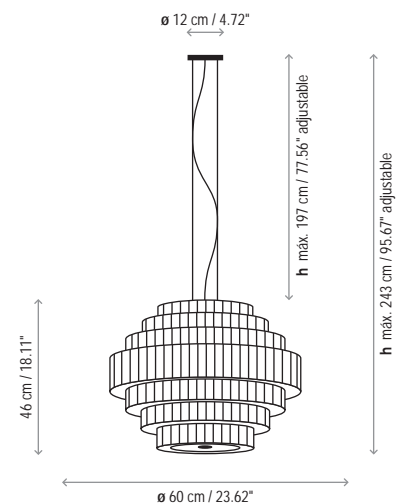

Mos - 01

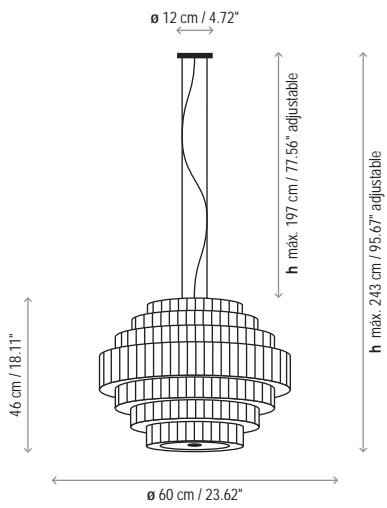

Mos - 02

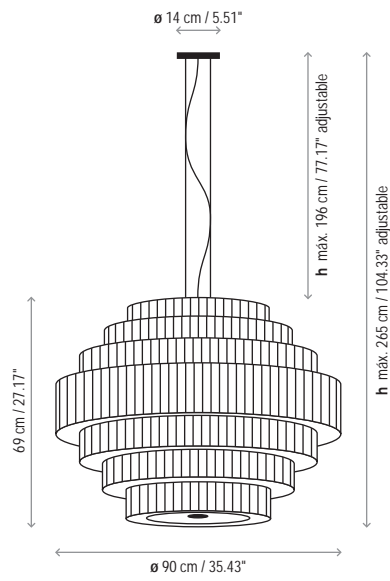

Mos - 03

