



WWW.KUCHT.COM



BE A **PRO** IN YOUR KITCHEN

Outdoor Kitchen | Gas Pizza Oven

KUCHTNAPOLI

INSTALLATION GUIDE AND USER MANUAL

APPLICABLE MODEL: KUCHTNAPOLI

SAFETY INFORMATION

Please read and understand this entire manual before attempting to assemble, operate or install the product. This appliance has been tested to and complies with the ANS Z21.89/CSA1.18-2017, outdoor cooking gas appliance. When connecting to a fixed piping system, the installation must conform to local codes or in the absence of local codes, to the National Fuel Gas Code. ANSI Z223.1.NFPA 54; National Fuel Gas Code; National Gas and Propane Installation Code, CSA B149.1; or Propane storage and Handling Code, CSA B149.2, as applicable. This manual contains important information about the assembly, operation and maintenance of this pizza oven. Keep this manual for future reference and to educate new users of this product. This manual should be read in conjunction with the labeling on the product. Safety precautions are essential when any mechanical or propane fueled equipment is involved. These precautions are necessary when using, storing, and servicing. Using this equipment with the respect and caution demanded will reduce the possibilities of personal injury or property damage. The following symbols shown below are used extensively throughout this manual. Always heed these precautions, as they are essential when using any mechanical or fueled equipment.

! DANGER

If you smell gas:

- Shut off gas to the appliance.
- Extinguish any open flame.
- If odour continues, keep away from the appliance and immediately call your gas supplier or fire department.

! WARNING

Do not store or use gasoline, or other flammable vapours and liquids in the vicinity of this or any other appliance. An LP-cylinder not connected for use shall not be stored in the vicinity of this or any other appliance.

! WARNING

For Outdoor Use Only.

! DANGER

! DANGER

CARBON MONOXIDE HAZARD

This appliance can produce carbon monoxide which has no odour. Using it in an enclosed space can kill you. Never use this appliance in an enclosed space such as a camper, tent or home.



! WARNING

Improper installation, adjustment, alteration, service or maintenance can cause property damage, injury or death. Read the installation, operation and maintenance instructions thoroughly before installing or servicing this equipment.



**DANGER**

DANGER indicates an imminently hazardous situation which, if not avoided, will result in death or serious injury.

Failure to comply with the precautions and instructions provided with this pizza oven can result in death, serious bodily injury and property loss or damage from hazards of fire, explosion, burn, asphyxiation, and/or carbon monoxide poisoning. Only persons who can understand and follow the instructions should use or service this pizza oven.

**DANGER****• EXPLOSION - FIRE HAZARD**

- Keep solid combustibles, such as building materials, paper or cardboard, a safe distance away from the pizza oven as recommended by the instructions.
- Provide adequate clearances around air openings into the combustion chamber.
- Never use the pizza oven in spaces which do or may contain volatile or airborne combustibles, or products such as gasoline, solvents, paint thinner, dust particles or unknown chemicals
- During operation, this product can be a source of ignition. Keep pizza oven area clear and free from combustible materials, gasoline, paint thinner, cleaning solvents and other flammable vapours and liquids. Do not use pizza oven in areas with high dust content. Minimum pizza oven clearances from combustible materials: 36 inches from the sides and back.

**WARNING**

Certain materials or items, when stored under the pizza oven, will be subjected to radiant heat and could be seriously damaged.

Alert children and adults to the hazards of high surface temperatures. Stay away from these surfaces to avoid burning skin or igniting clothing.

Carefully supervise young children when in the vicinity of the pizza oven.

Do not hang clothing or any other flammable materials from the pizza oven, or place on or near the pizza oven.

Replace any guard or protective device removed for servicing the appliance prior to placing back in service.

Installation and repair should be done by a qualified service person. The pizza oven should be inspected before use and annually by a qualified service person.

More frequent cleaning may be required as necessary. It is imperative that the control compartment, burners, and circulating air passageway of the appliance be kept clean.

**WARNING**

- This product is fueled by propane gas. Propane gas is invisible, odourless, and flammable. An odourant is normally added to help detect leaks and can be described as a “rotten egg” smell. The odourant can fade over time so leaking gas is not always detectable by smell alone.
- Propane gas is heavier than air and leaking propane will sink to the lowest level possible. It can ignite by ignition sources including matches, lighters, sparks or open flames of any kind many feet away from the original leak. Use only propane gas set up for vapor withdrawal.
- Store or use propane gas in compliance with local ordinances and codes or with ANSI/NFPA 58. Turn off propane when not in use.

**WARNING**

We cannot foresee every use which may be made of our pizza oven.

Check with your local fire safety authority if you have questions about pizza oven use.

Other standards govern the use of fuel gases and heat producing products for specific uses. Your local authorities can advise you about these. If no local codes exist, follow National Fuel Gas Code, ANSI Z223.1. In Canada, installation must conform to local codes.

If no local codes exist, follow the current National standards of CANADA CAN/CGA-B 149.2.

**DANGER**

Do not store or use gasoline or other flammable vapours and liquids in the vicinity of this or any other appliance. An LP-cylinder not connected for use shall not be stored in the vicinity of this or any other appliance.

Never leave pizza oven unattended when hot or in use.

Keep out of reach of children.

**WARNING**

Don't burn solid fuels in this appliance.

**WARNING**

Improper installation, adjustment, alteration, service or maintenance can cause property damage, injury or death. Read the installation, operation and maintenance instructions thoroughly before installing or servicing this equipment.

**DANGER****CARBON MONOXIDE HAZARD**

This pizza oven is a combustion appliance.

All combustion appliances produce carbon monoxide (CO) during the combustion process. This product is designed to produce extremely minute, non-hazardous amounts of CO if used and maintained in accordance with all warnings and instructions. Do not block air flow into or out of the pizza oven. Carbon Monoxide (CO) poisoning produces flu-like symptoms, watery eyes, headaches, dizziness, fatigue and possibly death. You can't see it and you can't smell it. It's an invisible

killer. If these symptoms are present during operation of this product get fresh air immediately!

For outdoor use only.

Never use inside house, or other unventilated or enclosed areas.

This pizza oven consumes air (oxygen).

WELCOME TO THE KUCHT FAMILY







IMPORTANT SAFETY WARNINGS

WE WANT YOU TO ASSEMBLE AND USE YOUR PIZZA OVEN AS SAFELY AS POSSIBLE.

THE PURPOSE OF THIS SAFETY ALERT SYMBOL  IS TO ATTRACT YOUR ATTENTION TO POSSIBLE HAZARDS AS YOU ASSEMBLE AND USE YOUR PIZZA OVEN.

WHEN YOU SEE THE SAFETY ALERT SYMBOL  PAY CLOSE ATTENTION TO THE INFORMATION WHICH FOLLOWS!

 READ ALL SAFETY WARNINGS AND INSTRUCTIONS CAREFULLY BEFORE ASSEMBLING AND OPERATING YOUR PIZZA OVEN.

-  **DANGER:** Indicates an imminently hazardous situation which, if not avoided, will result in death or serious injury.
-  **WARNING:** Be alert to the possibility of serious bodily injury if the instructions are not followed. Be sure to read and carefully follow all of the messages.
-  **CAUTION:** Indicates a potentially hazardous situation which, if not avoided, may result in minor or moderate injury.

CALIFORNIA PROPOSITION 65 WARNING

This product contains chemicals, including lead in the brass of certain component parts that are known to the State of California to cause cancer, and birth defects of other reproductive harm.

Wash hands after handling. When used, this product emits fuel combustion chemicals that are known to the State of California to cause cancer, and birth defects or other reproductive harm.

Follow all instructions in this manual and use only in well ventilated, outdoor area.



GENERAL WARNINGS:

- Leak test all connections before first use, even if pizza oven was purchased fully assembled and after each tank refill. Check the propane tank rubber seal for damage.
- Always check the pizza oven and propane tank prior to each use as indicated in the 'Checking for Leaks' & 'Pre-start Check-List' sections of this manual.
- Never use natural gas in a unit designed for liquid propane gas.
- Never use charcoal, lava rocks or wood briquettes in a gas pizza oven. Flavoring chips must be contained in a metal smoking box to contain ash and prevent fires.
- Ensure flames come out of all burner ports during each use. Spiders and insects like to build nests in burner holes. Blocked burner tubes can prevent gas flow to the burners and could result in a burner tube fire or fire beneath the pizza oven.
- Never check for leaks using a match or open flame.
- Never use or store gasoline, lighter fluid, paint thinner, or other flammable vapors and liquids or combustible materials in or near your pizza oven.
- DO NOT block ventilation areas in sides, back or cart compartment of pizza oven.
- DO NOT cover cooking grates or other components with aluminum foil, as this blocks ventilation and damage to pizza oven or personal injury may occur.
- Never place more than 15 pounds on the side tables. DO NOT lean on the side tables, DO NOT lift pizza oven using side tables.
- Keep children and pets away from hot pizza oven. DO NOT allow children to use or play near this pizza oven.
- DO NOT leave the pizza oven unattended while ON or in use.
- DO NOT allow the gas hose to come in contact with hot surfaces. Redirect the gas hose if necessary.
- DO NOT allow grease or hot drippings to fall on hose and regulator assembly. If this occurs, turn gas supply OFF at once. Empty grease tray/cup and clean the hose and regulator assembly and inspect for damage before use.
- Never cook on the pizza oven without the grease cup/tray in position.
- DO NOT use water on a grease fire. Closing the lid to extinguish a grease fire is not possible. Use type BC dry chemical fire extinguisher or smother with dirt, sand or baking Soda.
- DO NOT use while under the influence of drugs or alcohol.
- **FOR OUTDOOR USE ONLY. DO NOT operate indoors or in an enclosed area such as garage, shed or Breezeway.**
- Position your pizza oven outdoors on a non-combustible level surface in a well-ventilated location, a safe distance 10 foot(3.2m) from combustible materials, buildings and overhangs.
- Apartment dwellers: Check with management and follow the requirements and fire codes for using an LP gas pizza oven in your apartment complex. Only use outside on the ground (not on a balcony, patio, garage, etc.) with a 15 foot (4.6m) minimum clearance on all sides from any wall, structure or combustible Material.
- Maintain a minimum clearance of 36 inches (91cm) on all sides of pizza oven, check railings, walls or other combustible material. Not adhering to these clearances may prevent proper ventilation and can increase the risk of a fire and/or property damage, which could also result in personal injury. DO NOT use pizza oven under overhead unprotected combustible construction.
- DO NOT use or install this pizza oven in or on a recreational vehicle and/or boat.
- DO NOT build this model pizza oven in any built-in or slide in construction.
- If a bristle brush is used to clean any of the cooking surfaces, ensure no loose bristles remain on the cooking surfaces prior to baking as loose bristles may attach to food.
- DO NOT store items in cart that can catch fire or damage your pizza oven(such as swimming pool supplies/chemicals, table cloth).
- Pizza oven is hot when in use. To avoid burns:
 - ▲ DO NOT attempt to move the pizza oven.▲ Block the wheels so the unit does not accidentally move.▲ Wear protective gloves or oven mitts.
 - ▲ DO NOT touch any hot pizza oven surfaces.▲ DO NOT wear loose clothing or allow hair to come in contact with pizza oven.
- Not for commercial use. DO NOT use this pizza oven for anything other than its intended purpose.

⚠ USE CAUTION AND COMMON SENSE WHEN OPERATING YOUR GAS PIZZA OVEN. FAILURE TO ADHERE TO THE SAFETY WARNINGS AND GUIDELINES IN THIS MANUAL COULD RESULT IN SEVERE BODILY INJURY OR PROPERTY DAMAGE. SAVE THIS MANUAL FOR FUTURE REFERENCE.

EXPLODED VIEW

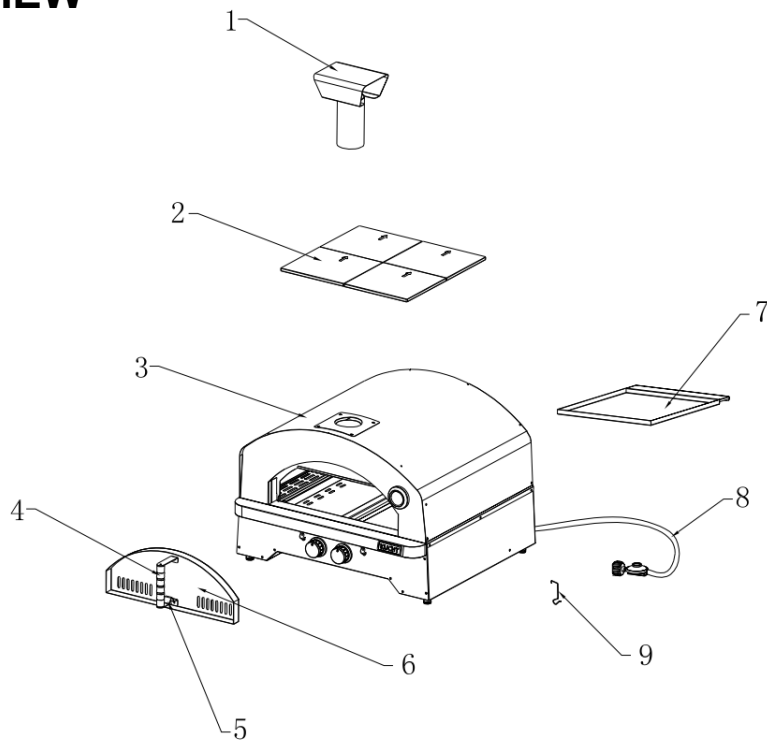

PART LIST

NO.	Description	QTY
1	Pizza oven chimney	1
2	Pizza stone	4
3	Pizza oven	1
4	Door handle	1
5	Door handle connector	1
6	Pizza oven door	1
7	Grease tray	1
8	LPG regulator and hose	1
9	hook	1

ASSEMBLY INSTRUCTIONS

- **Before getting started with the assembly:**
 - ◆ Select a level surface that does not have cracks or openings to avoid any small components or hardware from getting lost.
 - ◆ Level surface must be smooth/soft to avoid scratching or damaging any surface finish of all components.
 - ◆ Ensure the level surface is large enough to layout all components and hardware.
- Tighten hardware and connections by hand first, then fully tighten with screwdriver or wrench. Be cautious to not over tighten which may damage surface or strip hardware.
- Follow all steps properly when assembling your pizza oven.
- Before starting pizza oven operation:
 - ◆ Perform Leak Test
 - ◆ Fill the LP gas cylinder with type 1 cylinder valve.
- After baking:
 - ◆ Turn off the cylinder valve
 - ◆ Turn both burner control knobs to 'OFF' position.
- Loading capacity
 - ◆ Maximum loading weight of side tables: less or equal to 15 lbs (6.8kg)
 - ◆ Maximum loading weight of warming rack: less or equal to 8.8 lbs (4kg)

Assembly

1.

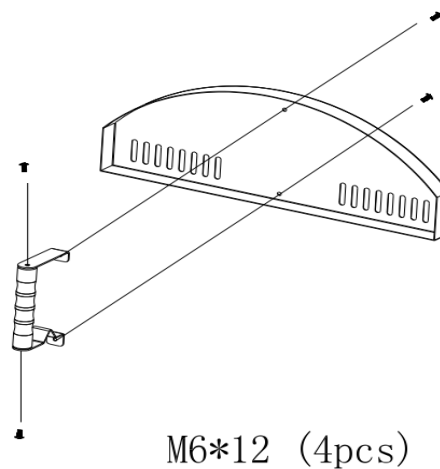

2.

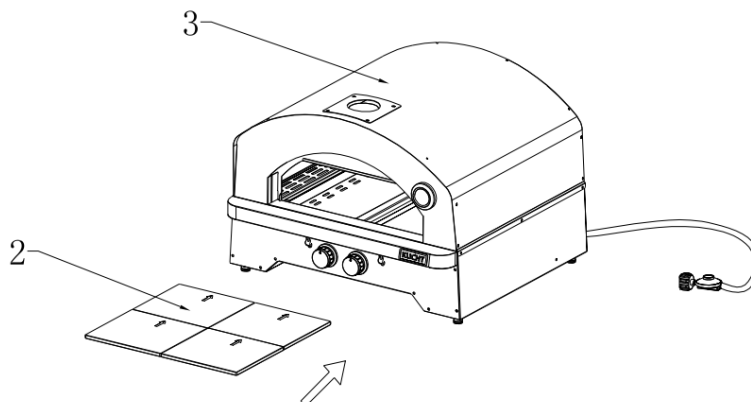

3.

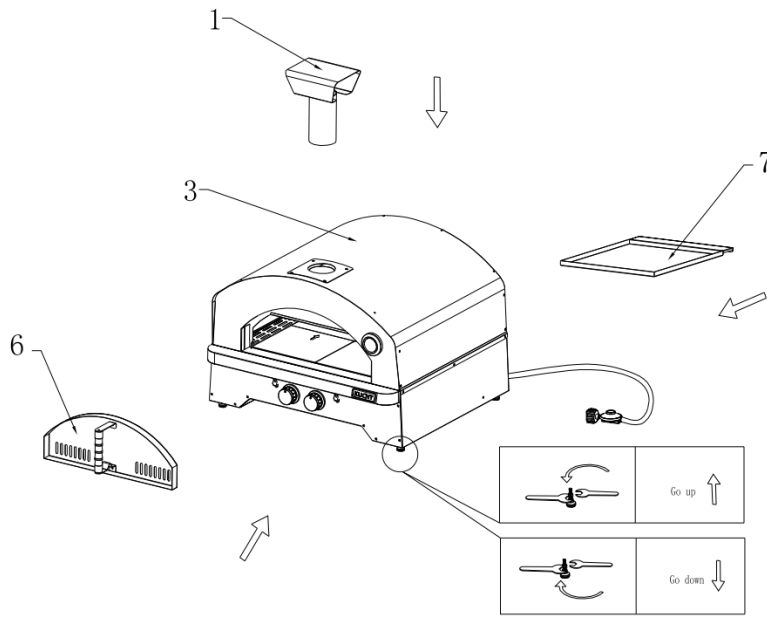

4.

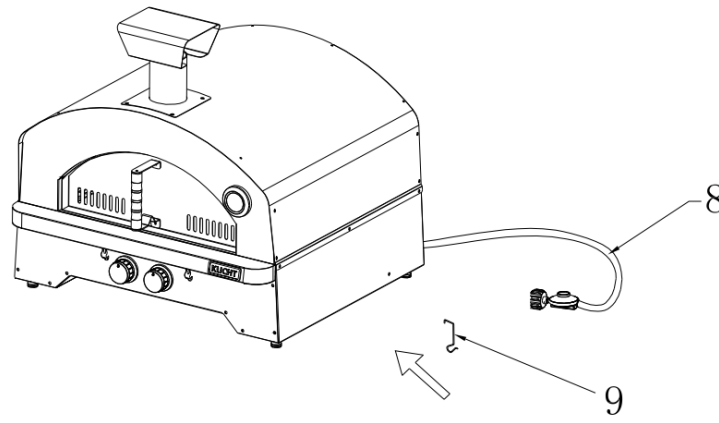

5.

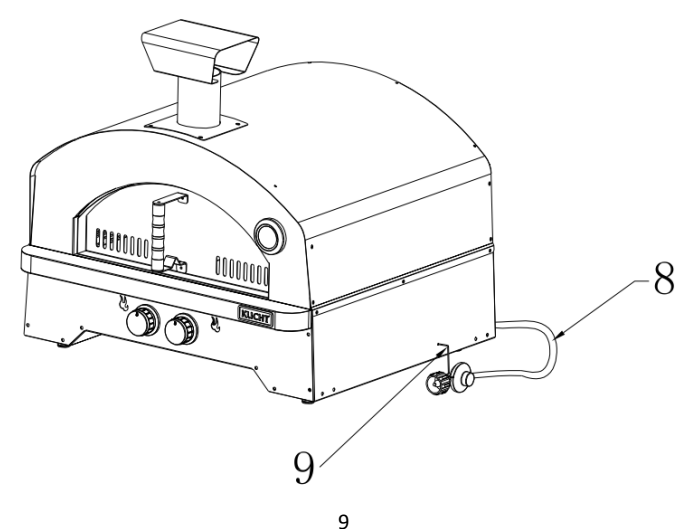

ASSEMBLY INSTRUCTIONS FOR NG

NG and LP conversion:

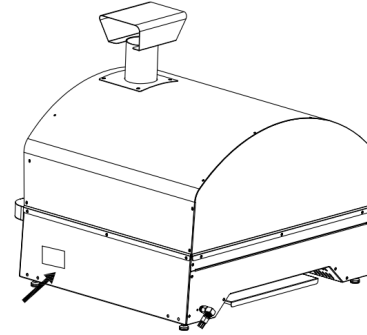

A. Change the orifice

- This kit converts your pizza oven for natural gas use at 7 inch water column supply pressure. Verify supply pressure with your local gas company. If supply pressure is different than 7 inch, contact a certified plumber for assistance.
- Placing markings provided in the kit in the appropriate location on the converted appliance.

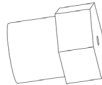
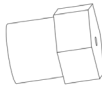

Orifice size: NG Main burner=1.52mm, NG Rear burner=1.32mm

Propane Main burner=1.08mm, Propane Rear burner=0.95mm

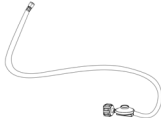
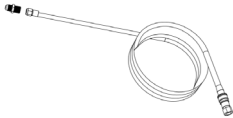
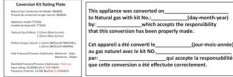
LP TRANSFORMATION PART LIST		NG TRANSFORMATION PART LIST	
① LP Main burner 1.08 mm orifice×1 14,000BTU		① NG Main burner 1.52 mm orifice ×1 14,000BTU <i>(NOT INCLUDED)</i>	
② LP Rear burner 0.95 mm orifice×1 10,000BTU		② NG Rear burner 1.32 mm orifice×1 10,000BTU <i>(NOT INCLUDED)</i>	
③ LP hose assembly		③ NG hose assembly <i>(NOT INCLUDED)</i>	
		④ Conversion Kit label <i>(NOT INCLUDED)</i>	

Inlet manifold pressure

For Propane-----11 inch water column

For NG-----7 inch water column

ASSEMBLY INSTRUCTIONS FOR NG



WARNING FIRE, EXPLOSION, AND CARBON-MONOXIDE HAZARD

If the information in these instructions is not followed exactly, a fire, explosion, or production of carbon monoxide may result causing property damage, personal injury, or loss of life.

This conversion kit shall be installed by a qualified agency in accordance with the appliance manufacturer's instructions and all applicable codes and requirements of the Authority Having Jurisdiction. The qualified agency is responsible for the proper installation of this kit. The installation is not proper and complete until the operation of the converted appliance is checked as specified in the manufacturer's instructions supplied with the kit.

Caution: Before proceeding with the conversion, shut off the gas supply to the appliance prior to disconnecting the electrical power."

Step 1

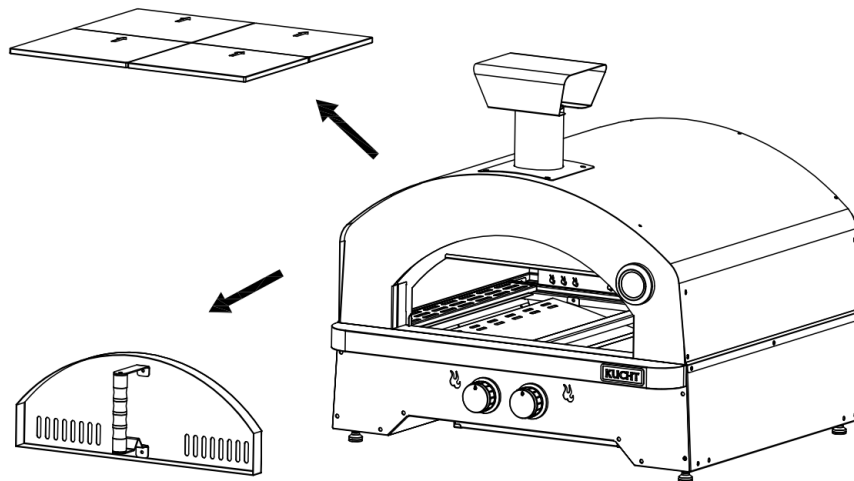

ASSEMBLY INSTRUCTIONS FOR NG

Step 2

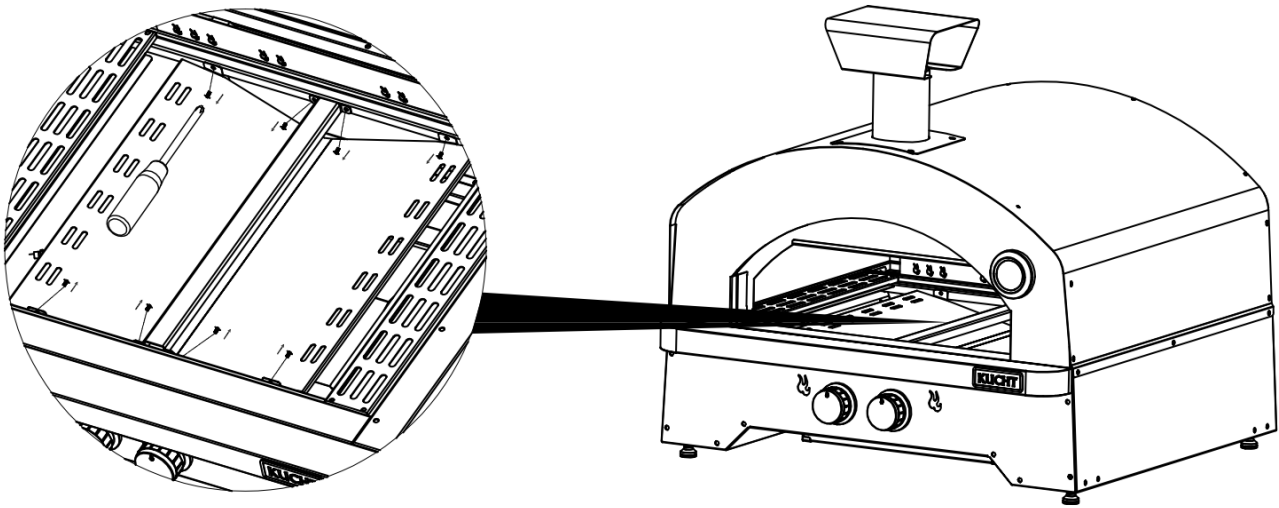

Step 3

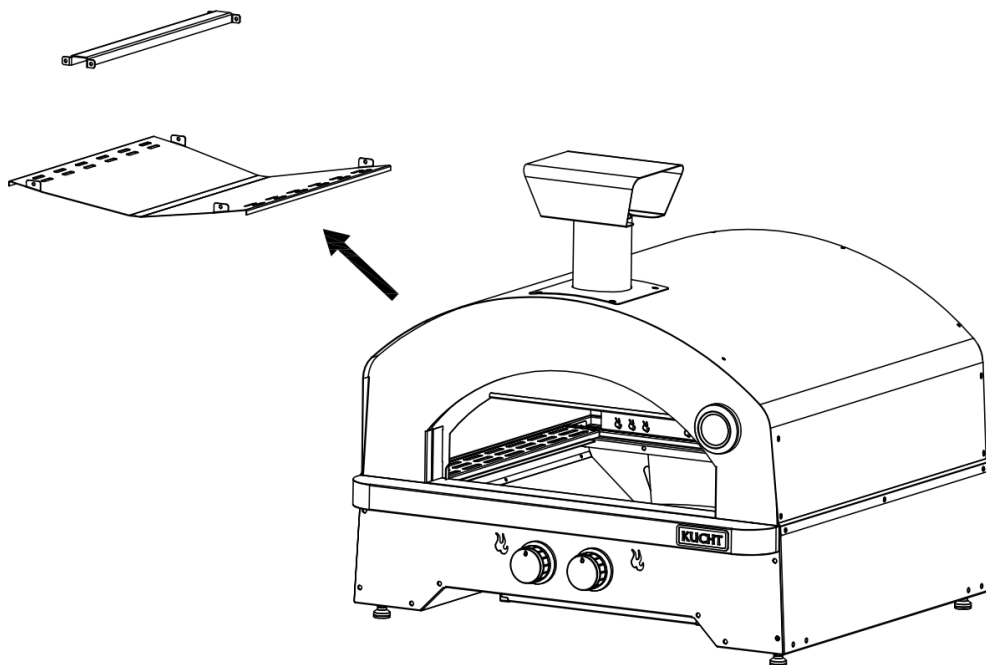

ASSEMBLY INSTRUCTIONS FOR NG

Step 4

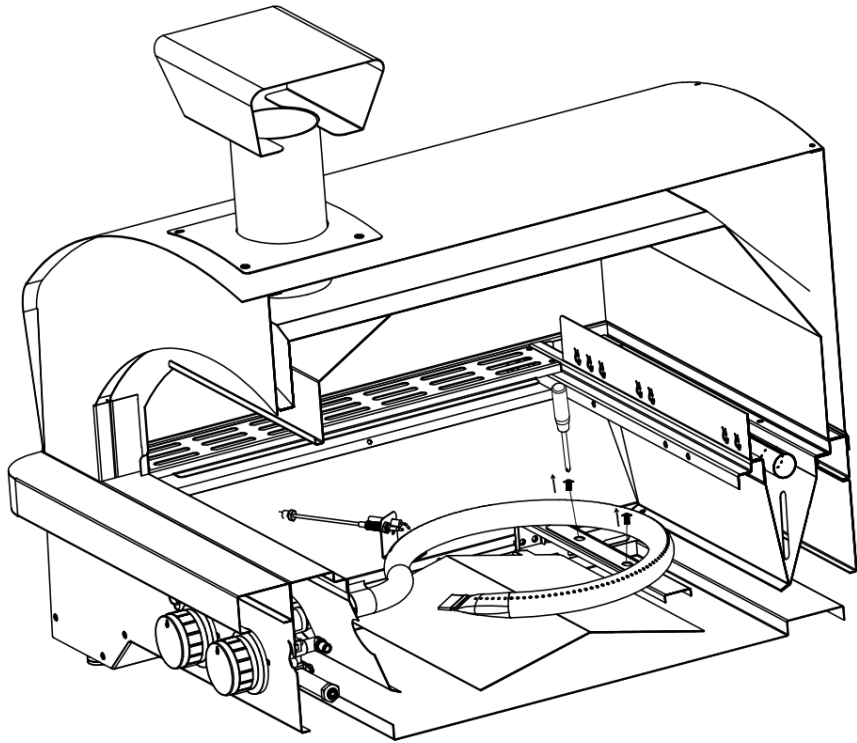

Step 5

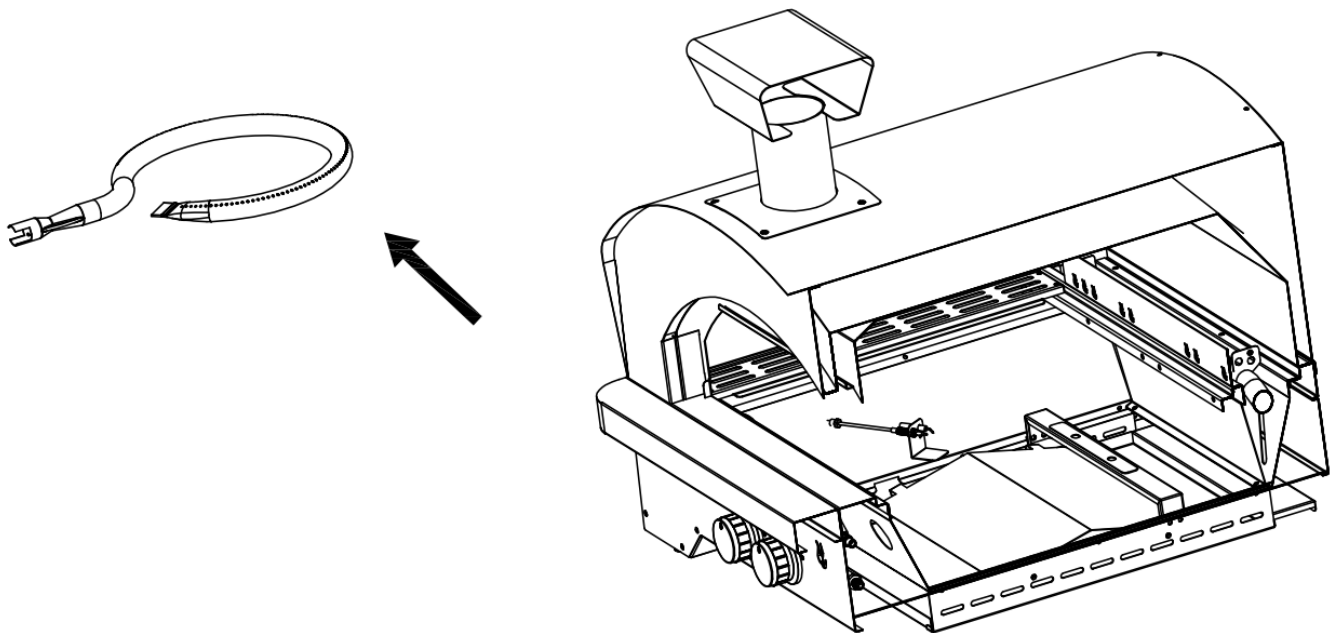

Step 6

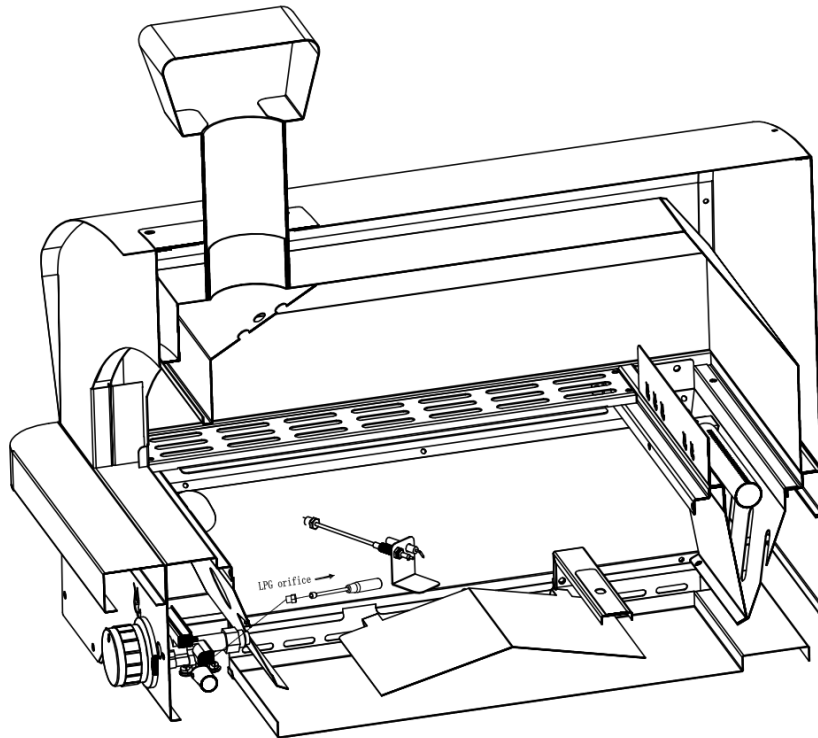

Step 7

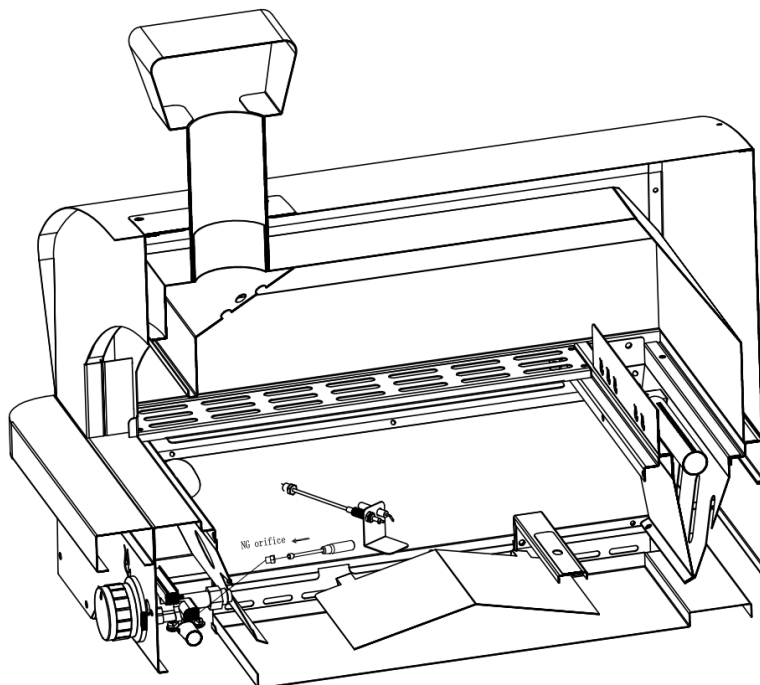

Step 8

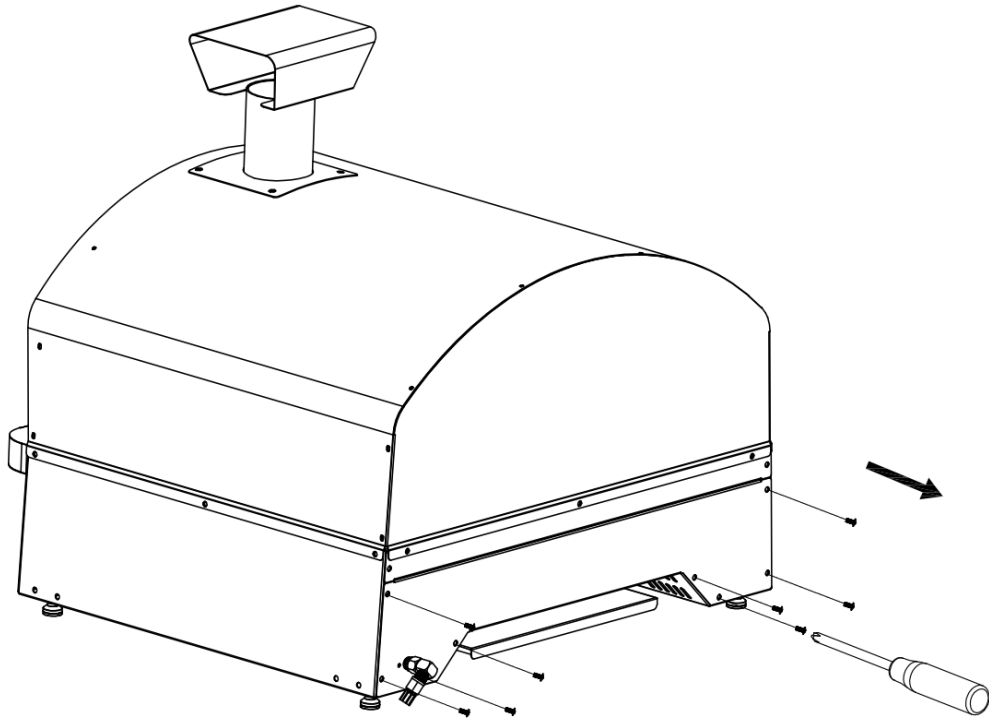

Step 9

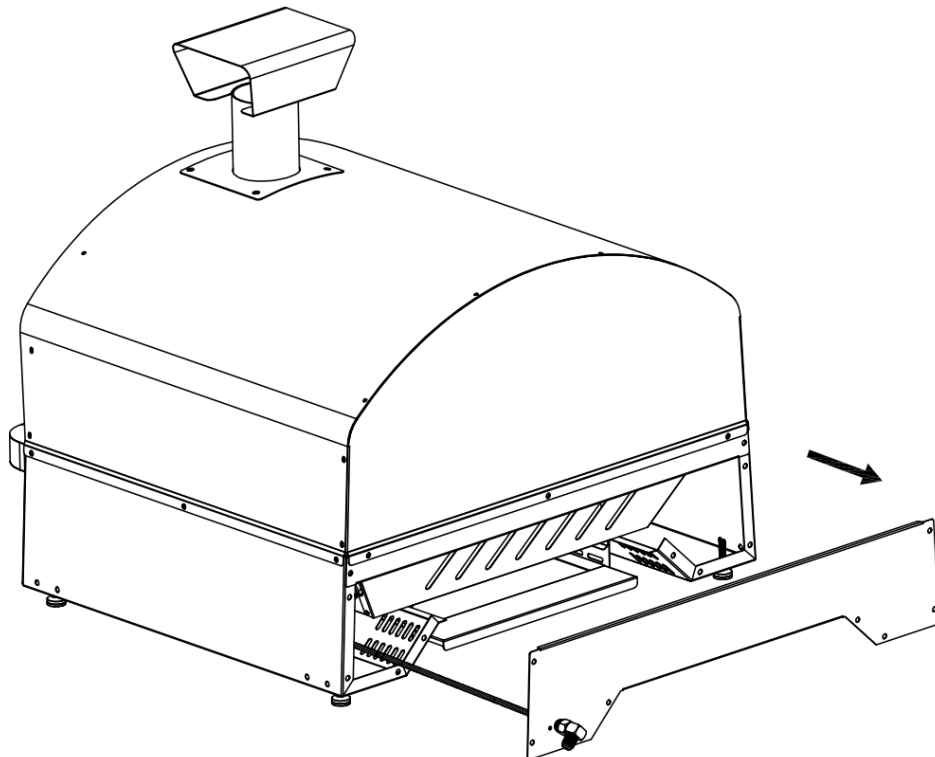

ASSEMBLY INSTRUCTIONS FOR NG

Step 10

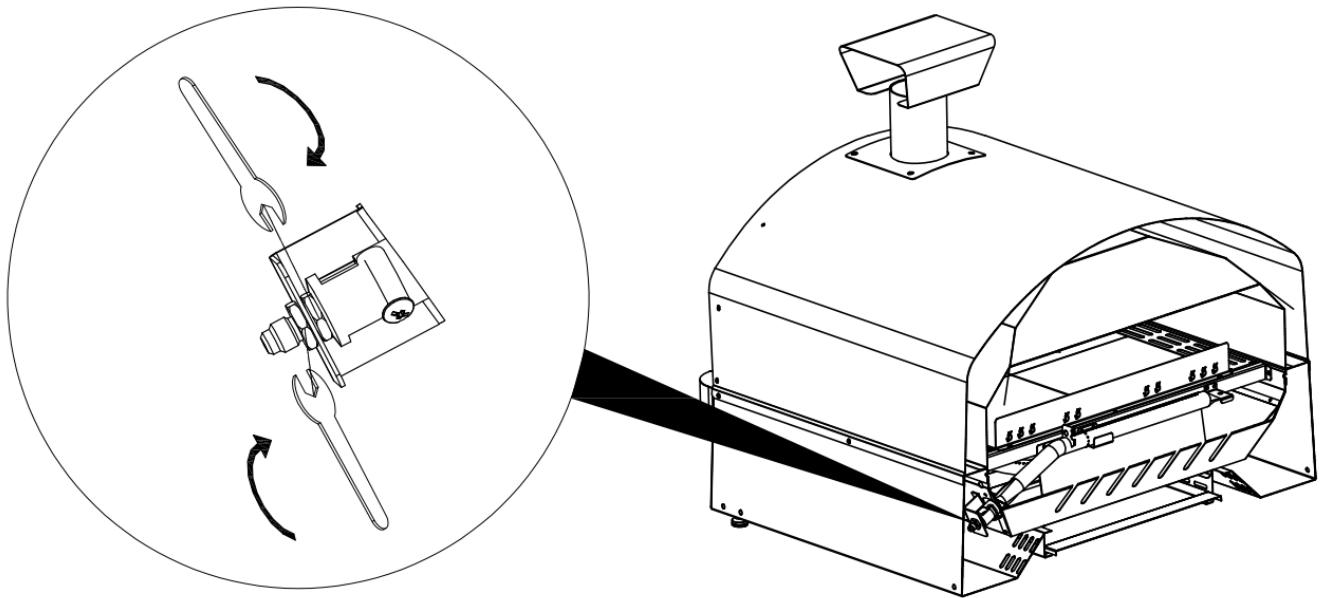

Step 11

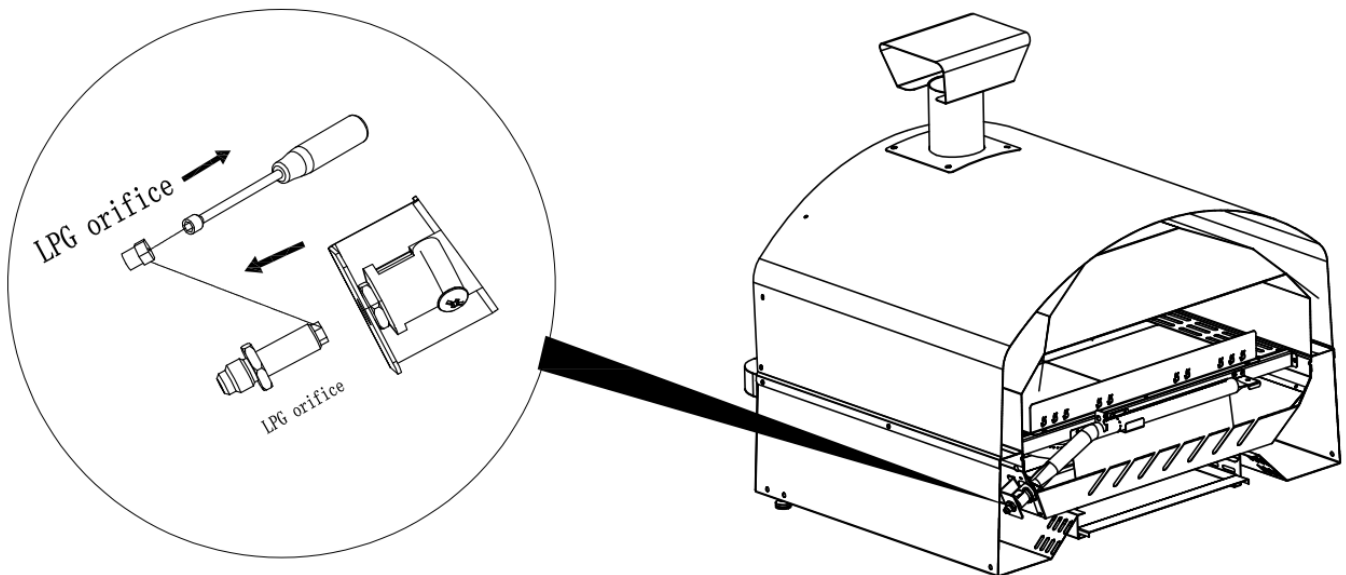

ASSEMBLY INSTRUCTIONS FOR NG

Step 12

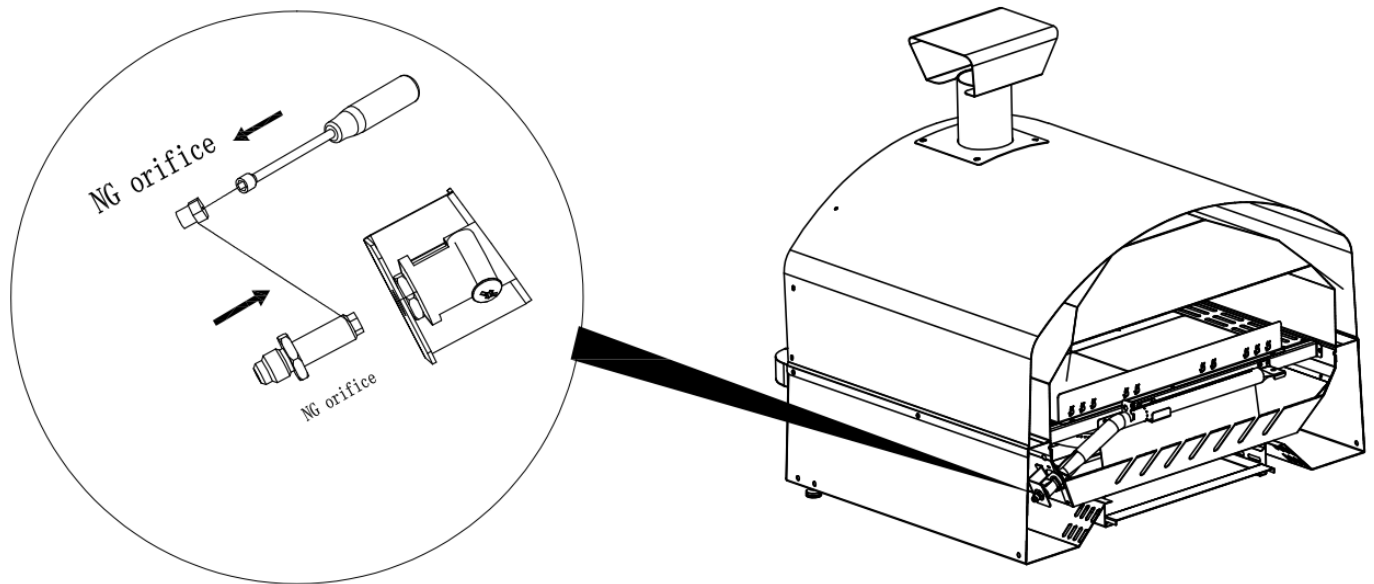

Step 13

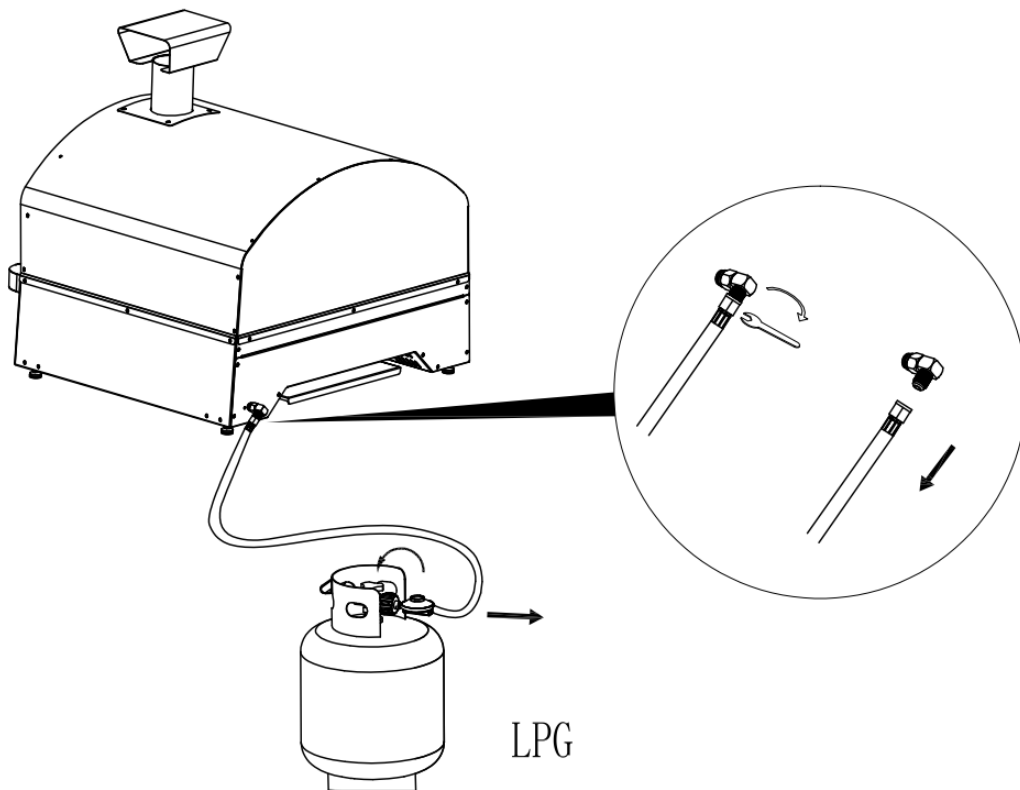

ASSEMBLY INSTRUCTIONS FOR NG

Step 14

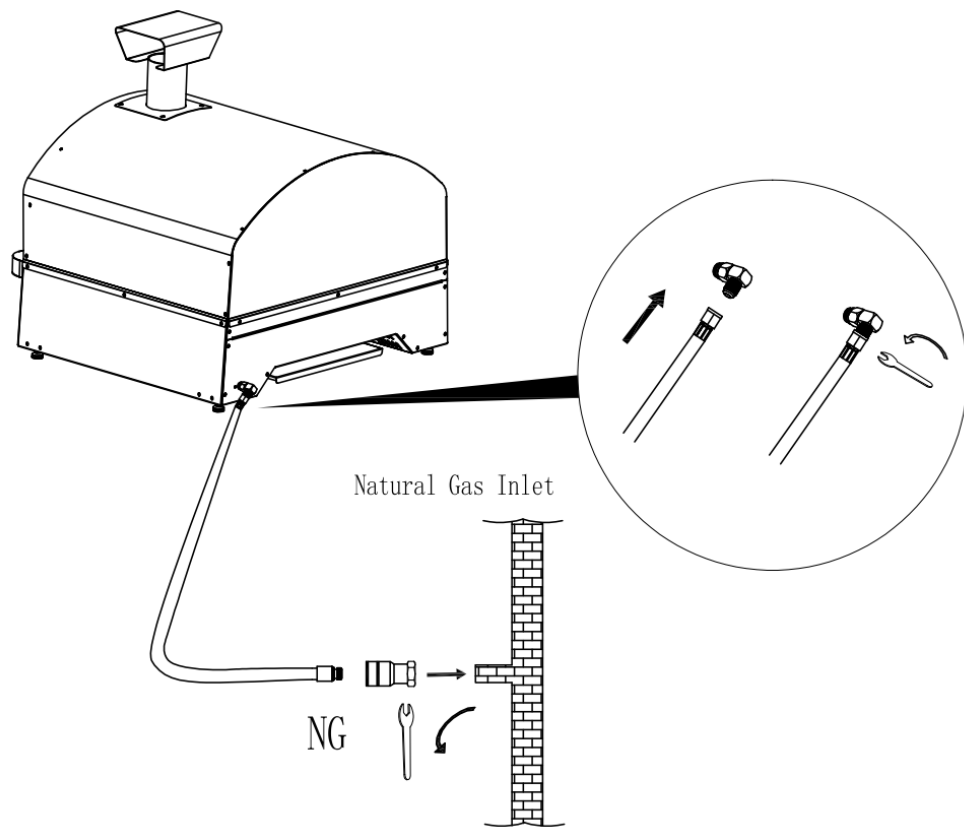

LIGHTING ROD INSTRUCTION

Step 1

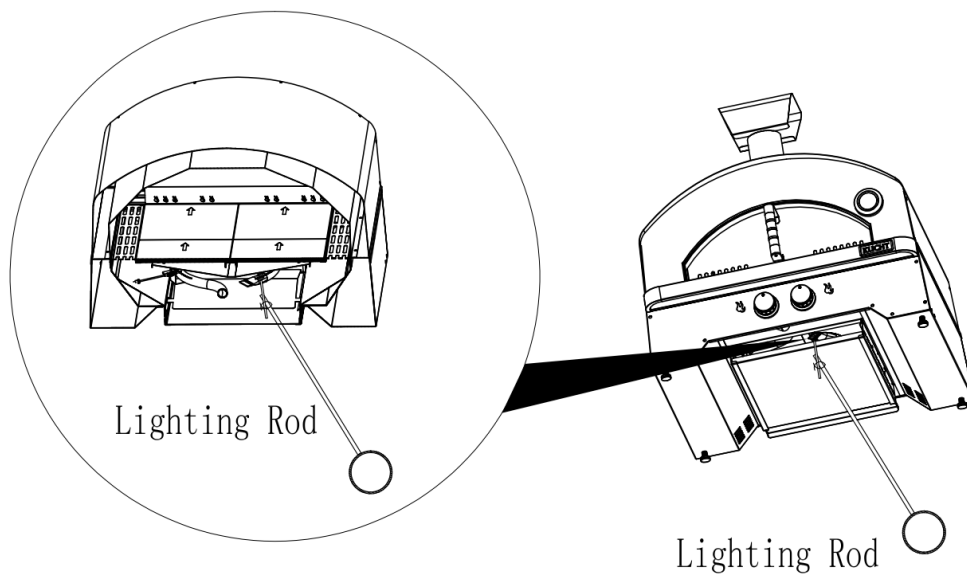

Step 2

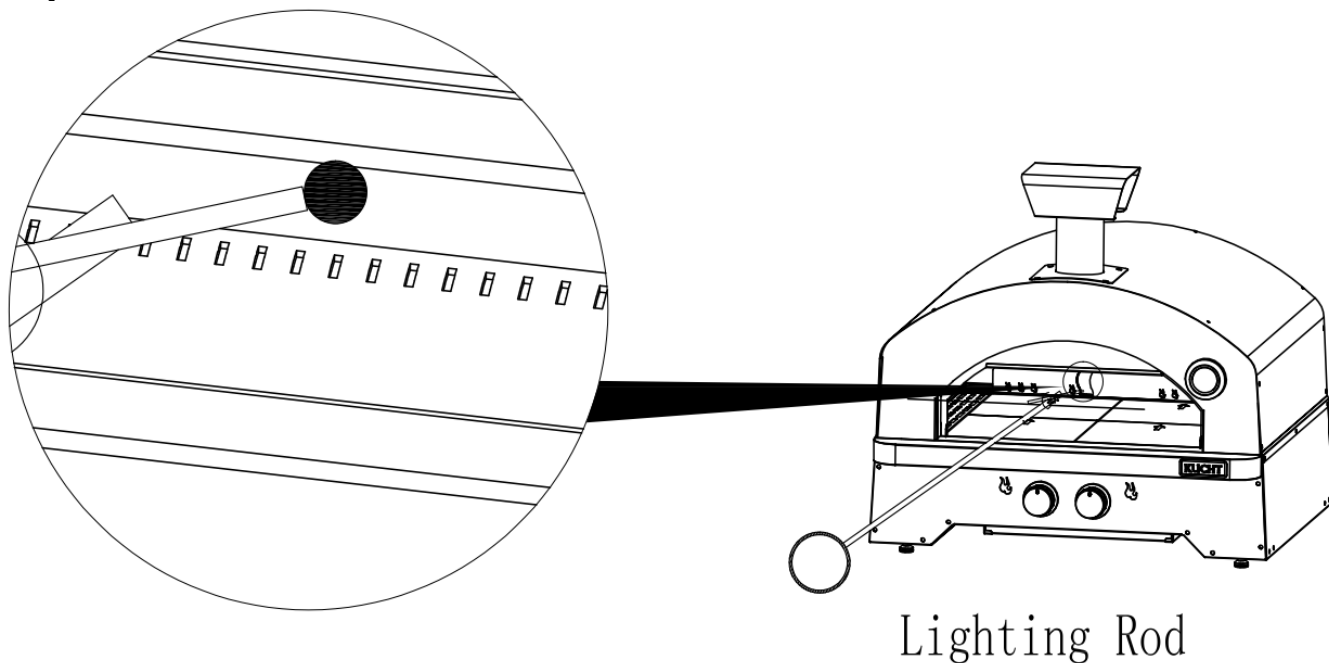

Lighting Rod

LP GAS CYLINDER (TANK) SPECIFICATIONS AND INSTALLATION:

WARNING

- ◆ ONLY connect this pizza oven to a Type 1 cylinder valve. The Type 1 valve can be identified with the large external threads on the valve outlet.
- ◆ DO NOT connect to a propane cylinder exceeding a 20 lb. (9.1kg) capacity.
- ◆ DO NOT connect to a cylinder that uses any other type of valve connection device.
- ◆ Inspect the propane tank valve rubber seal for cracks, wear or deterioration prior to use. A damaged rubber seal can cause a gas leak, possibly resulting in an explosion, fire or severe bodily harm.
- ◆ Turn off the cylinder valve when your pizza oven is not in use.
- ◆ Handle the tank with care.
- ◆ Always secure the cylinder in an upright position.
- ◆ Never connect an unregulated LP gas cylinder to your pizza oven.
- ◆ DO NOT expose LP gas cylinders to excessive heat or ignition sources.
- ◆ DO NOT store a spare LP gas cylinder under or near your pizza oven.
- ◆ Allow only qualified LP gas dealers to fill or repair your LP gas cylinder.
- ◆ DO NOT allow the cylinder to be filled beyond 80% capacity.

DANGER

- ◆ DO NOT store a spare LP gas cylinder (full or empty) under or near your pizza oven. This could cause excess pressure to be expelled through the vapor relief valve resulting in fire, explosion, or severe personal injury, including death.
- ◆ Propane gas is heavier than air and will collect in low areas. Proper ventilation is extremely important. Keep the ventilation opening(s) of the LP gas cylinder enclosure free and clear from obstructions and debris.
- ◆ DO NOT insert any foreign objects into the cylinder valve outlet as this could damage the rubber seal. Do not use propane tank with a damaged rubber seal. A damaged rubber seal can cause a gas leak, possibly resulting in explosion, fire, severe bodily harm, or death. Inspect rubber seal for cracks, wear or deterioration prior to use.

LP GAS CYLINDER (TANK) SPECIFICATIONS:

LP gas cylinder (not supplied with this pizza oven)

The LP (Liquid Propane) gas cylinder specifically designed to be used with this pizza oven must be 12" (30.5cm) diameter x 18" (45.7cm) tall and have a 20 lb. (9.1kg) capacity incorporating a Type 1 cylinder valve and an over-filling protection device (OPD).

This pizza oven is designed to fit Worthington, Manchester or SMPS brand 20 lb. (9.1kg) cylinders. Other branded DOT cylinders may fit this pizza oven if the cylinder has similar dimensions of the top and bottom rings.

The installation of this appliance must be in accordance with:

All applicable local codes, or in the absence of local codes, either:

- National Fuel Gas Code ANSI Z223.1 NFPA 54
- Natural Gas and Propane Installation Code: CAN/CGA B149.1
- Natural Gas Installation Code: CAN/CGA B149.1(Canada)
- Propane Installation Code: CAN/CGA B149.2(Canada)

To check your local codes, contact your local LP gas dealer or natural gas company. This pizza oven is not intended to be connected to a natural gas supply line. If an external electrical source is utilized, it must be electrically grounded in accordance with local codes, or in the absence of local codes, with the National Electrical Code, NASI/NFPA 70, or the Canadian Electrical Code, CSA 22.1.

When purchasing or exchanging a cylinder for your gas pizza oven, it must be constructed and marked in accordance with the specifications for LP gas cylinders of the U.S. Department of Transportation (DOT) or the National Standard of Canada, CAN/CSA-B339 Cylinders, Spheres and Tubes for Transportation of Dangerous Goods; and Commission, as applicable; and provided with a listed over-filling prevention device(OPD), and provided with a cylinder connection device compatible with connection for outdoor cooking appliances.

The cylinder must also be equipped with:

- A shut-off valve terminating in a Type 1 gas cylinder valve outlet.

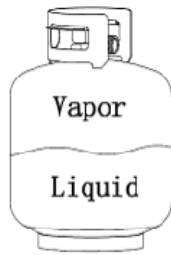

Correct



Wrong

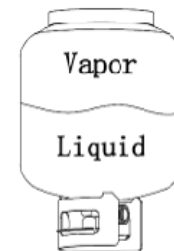

Wrong

- A Type 1 valve that prevents gas flow until a positive seal is obtained.
- An arrangement for vapor withdrawal.
- A collar to protect the cylinder shut-off valve.
- A safety relief device having direct communication with the vapor space of the cylinder.
- A listed over-filling prevention device (OPD).

FILLING THE LP GAS CYLINDER(TANK):

WARNING

- ◆ Allow only qualified licensed LP gas dealers to properly fill or repair your LP gas cylinder.
- ◆ New tanks should be purged prior to filling; inform LP gas dealer if you are using a new tank.
- ◆ DO NOT allow the cylinder to be filled beyond 80% capacity. Over-filled tanks can create a dangerous condition. Over-filled tanks can build up pressure and cause the relief valve to expel propane gas vapors. The vapor is combustible and if it comes in contact with a spark source or flame an explosion causing severe burns, bodily harm, or death could occur.
- ◆ Always use a protective cylinder cap when grill is not connected to cylinder.
- ◆ If you exchange a cylinder with a qualified exchange program, the new cylinder must have a Type 1 valve and an over-filling prevention device(OPD).
- ◆ Inspect the propane tank valve rubber seal for cracks, wear or deterioration prior to use.

LP GAS CYLINDER (TANK) RUBBER SEAL INSPECTION:

- Inspect the propane tank valve rubber seal for cracks, wear or deterioration prior to use. A damaged rubber seal can cause a gas leak, possibly resulting in an explosion, fire or severe bodily harm.
- Inspection should be done each time the propane tank is connected to the grill, has been exchanged or has not been used for more than 60 days.
- Do not use a propane tank with a damaged rubber seal. Exchange the tank or have the rubber seal replaced at a qualified propane filling station.

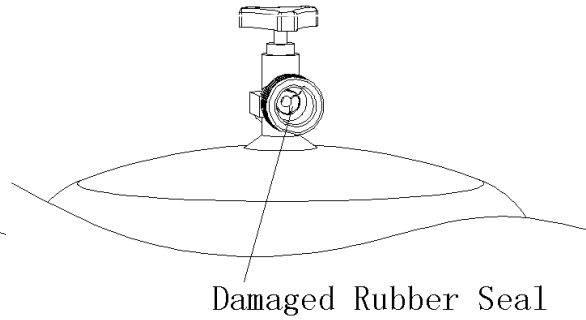
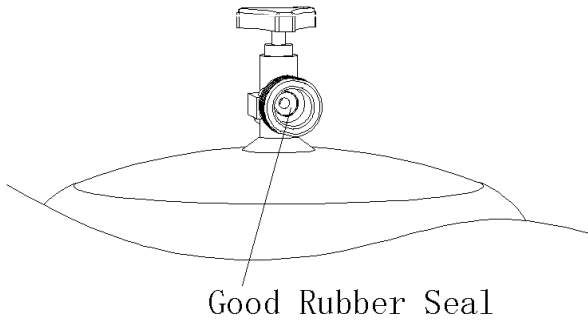

HOSE & REGULATOR SPECIFICATIONS AND INSTALLATION:

WARNING

- ◆ DO NOT attempt to connect pizza oven, as purchased for LP(propane) gas, to any other fuel supply source such as a natural gas line.
- ◆ DO NOT use any other pressure regulator/hose assembly other than the one supplied with your grill. Replacement pressure regulator/hose assembly must be obtained by contacting customer service at **866-685-8248**
- ◆ DO NOT attempt to adjust or repair a regulator. The regulator is designed to operate at a maximum output pressure of 11 inches of water column (2.74kPa).
- ◆ Ensure the tank valve is CLOSED prior to connecting the LP gas cylinder to your pizza oven. Turn the valve knob clockwise to properly close the valve. Read and follow all instructions and warnings on the supply hose safety tags. Read and follow all warnings in this manual concerning the safe use of LP gas cylinders and the hose and regulator before connecting cylinder to pizza oven.

HOSE & REGULATOR:

Your pizza oven is equipped with a Type 1 connection device with the following features:

1. The system will not allow gas flow from the cylinder until a positive connection to the valve has been made.
Note: The cylinder valve and all pizza oven burner knobs must be turned OFF before any connection is made or removed.
2. A regulator flow limiting device, when activated, restricts the flow of gas to 10 cubic feet per hour. If the flow limiting device is activated, perform Regulator Resetting Procedure.
Note: If your pizza oven will not get hot enough to cook, the flow limiting device may have been activated.

CONNECTING HOSE & REGULATOR:

1. Inspect the propane tank valve rubber seal for cracks, wear or deterioration prior to use. A damaged rubber seal can cause a gas leak, possibly resulting in an explosion, fire or severe bodily harm. Do not use a propane tank with a damaged rubber seal.
2. Attach or detach regulator to the LP gas cylinder only when cylinder is at rest in tank holder.
3. Check that the cylinder valve is closed by turning the knob clockwise.
4. Check that the pizza oven's burner control knobs are in the 'OFF' positions.
5. Visually inspect the hose assembly prior to each use for evidence of damage, excess wear, or deterioration. If found, replace the assembly before using your pizza oven. Only the manufacturer's supplied replacement should be used.

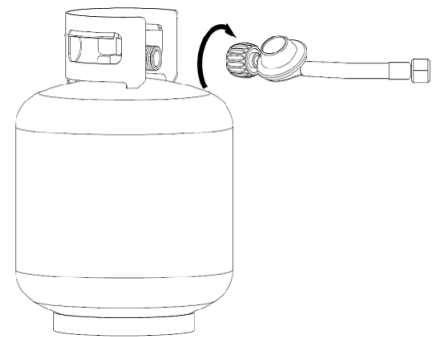

6. Remove the protective plastic cap from the cylinder valve.
7. Check that the hose does not contain kinks, that the cylinder does not have sharp edges, and does not contact surfaces that may become hot during use.
8. Hold regulator and insert the brass nipple into the LP cylinder valve outlet. Ensure that the device is centered properly.
9. Turn the large coupling nut clockwise by hand and tighten to a full stop. Take care to not cross-thread the coupling nut onto the cylinder valve. Do not use tools to tighten connection.
Note: If you are unable to make the connection, repeat Step 7 and 8.
10. Leak-check all fittings before lighting your pizza oven. See section on 'Leak Testing' of this manual.

REGULATOR RESETTING PROCEDURE:

If your pizza oven will not get hot enough to cook, the flow limiting device may have been activated.

Mini Reset: Turn All burner control knobs to 'OFF', turn off the cylinder valve. Wait one minute. Slowly turn cylinder valve ON and relight pizza oven.

If burner flame is higher and pizza oven heats up properly- proceed with cooking.

Full Rest: Turn All burner control knobs to 'OFF', turn off the cylinder valve. Disconnect hose and regulator from cylinder. Wait two minutes, reattach hose and regulator and perform leak test.

LEAK TESTING:

 **WARNING**

- ◆ Never use your pizza oven without leak testing all gas connections, hoses and propane tank. Follow the section on 'Leak Testing' of this manual for proper procedures.

 **DANGER**

To prevent fire or explosion hazard:

- ◆ DO NOT smoke or permit ignition sources in the area while conducting a leak test.
- ◆ Perform test OUTDOORS in a well-ventilated area that is protected from the wind.
- ◆ Never perform a leak test with a match or open flame.
- ◆ Never perform a leak test while the pizza oven is in use or while pizza oven is still hot.

WHEN TO PERFORM A LEAK TEST:

- After assembling your pizza oven and before lighting for the first time, even if purchased fully-assembled.
- Every time the LP gas cylinder is re-filled, exchanged or if any of the gas components are disconnected or replaced.
- Any time your pizza oven has been moved.
- At least once per year or if your pizza oven has not been used for more than 60 days.

CHECKING FOR LEAKS:



CAUTION:

Strong odors, colds, sinus congestion, etc. May prevent the detection of propane by smell. Use caution and common sense when testing for leaks.

Note: The leak test must be performed in an area that has adequate lighting in order to see if bubbles are developing and not in a windy or noisy area so larger leaks can be detected by smell or sound.

1. Create a mixture of 50% water and 50% liquid dishwashing soap.
2. Open the lid.
3. Ensure all control knobs are set to the ' OFF ' position.
4. Turn on the gas at the cylinder valve. Turn the cylinder valve knob counter-clockwise until fully opened. If you hear a rushing sound or smell gas, turn the gas off. Tighten any leaking connections. If leak is detected at connection nut and tightening does not stop leak, re-inspect propane tank rubber seal.
5. Create a mixture of 50% water and 50% liquid dishwashing soap.
6. Open the lid.
7. Ensure all control knobs are set to the ' OFF ' position.
8. Turn on the gas at the cylinder valve. Turn the cylinder valve knob counter-clockwise until fully opened. If you hear a rushing sound or smell gas, turn the gas off. Tighten any leaking connections. If leak is detected at connection nut and tightening does not stop leak, re-inspect propane tank rubber seal.
9. Apply the soapy water mixture to the following:
 - A Supply tank(cylinder) welds.
 - B Connection nut to tank valve.
 - C Back side of connection nut to brass nipple.
 - D Brass nipple connection into regulator.
 - E Regulator connections to gas supply hoses.
 - F Hose connection to gas manifold.
 - G The full length of gas supply hose.
 - H Tank valve to cylinder.
10. Check each place listed(A-H) for growing bubbles, which indicates a leak. Large leaks may not be detected by bubbles but should produce a rushing sound or gas smell.
11. Turn off gas supply at cylinder valve.
12. Turn on control knobs to release gas pressure in hose.
13. Turn control knobs to ' OFF ' position.
14. Tighten any leaking connections. If leak is detected at connection nut and tightening does not stop leak, re-inspect propane tank rubber seal.
15. Repeat soapy water test until no leaks are detected.
16. Turn off gas supply at cylinder valve until you are ready to use your pizza oven.
17. Wash off soapy residue with cold water and towel dry.
18. Wait 5 minutes to allow all gas to evacuate the area before lighting pizza oven.

It is very important to keep your appliance's clear and away from any combustible materials. Maintain at least 36 inches of clearances from sides and back and do not use under overhead combustible construction.

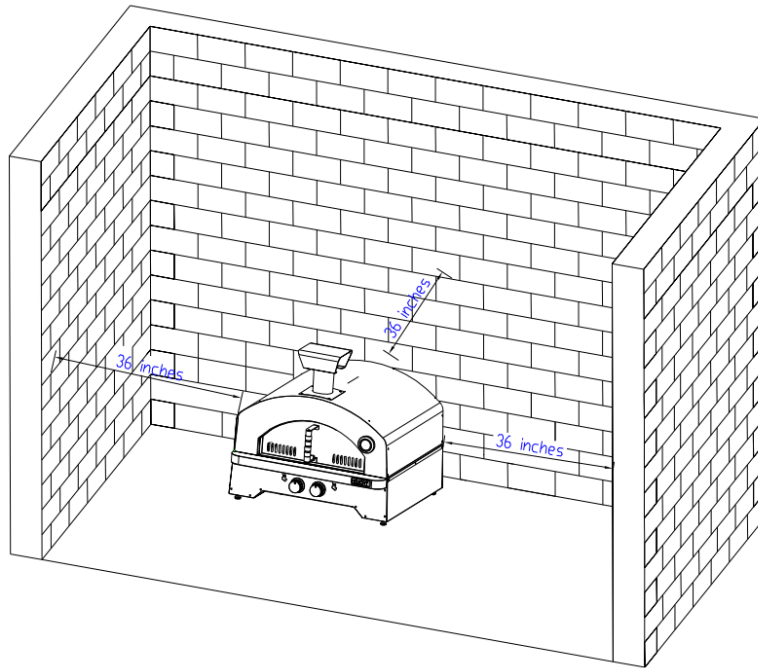

The cylinder should maintain at least 8 inches from the appliance. The distance between the desktop and the ground should be more than 18 inches.

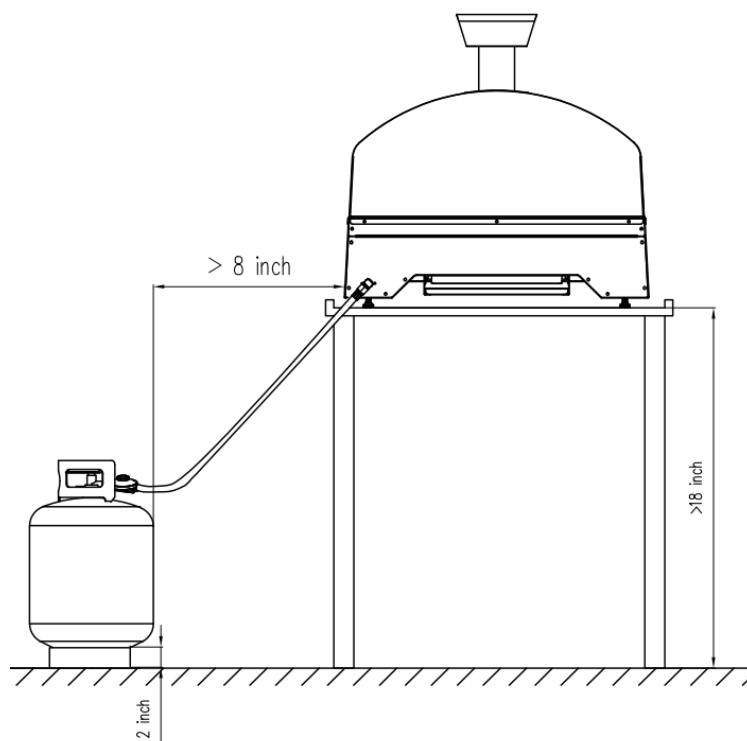

PRE-START CHECK LIST:

DANGER

Property damage, bodily harm, severe burns, and death could result from failure to follow these safety steps. These steps should be performed after the pizza oven has been assembled and prior to each use. DO NOT operate this pizza oven until you have read and understand ALL of the warnings and instructions in this manual.

- Ensure that the pizza oven is properly assembled.
- Inspect the gas supply hose for burns, chaffing, kinks, and proper routing before each use. If it is evident there is excessive abrasion or wear, or the hose is cut, it must be replaced prior to the pizza oven being used. Replace the hose and regulator, which can be obtained by contacting customer service at 866-685-8248
- Leak-check all gas connections, hose and propane tank. See section on 'Leak Testing'.
- Ensure that all electrical supply cords are properly grounded. Keep any electrical supply cord and the fuel supply hose away from any heated surfaces. Hose should be at least 3" from hot surfaces.
- Position your pizza oven on a non-combustible level surface in well ventilated location, a safe distance 10ft (3.1m) from combustible materials, buildings and overhangs.
- Properly place the empty grease cup under the grease drain hole in the bottom of the pizza oven to catch grease during use.
- DO NOT block ventilation areas in sides, back or cart compartment of pizza oven.

LIGHTING INSTRUCTIONS:

WARNING

Read, understand and follow all warnings and instructions contained in this manual. DO NOT skip any of the warnings and instructions contained in the preceding sections of this manual.

Follow the instructions exactly.

1. OPEN THE PIZZA OVEN DOOR before attempting to light a burner so that fumes do not accumulate inside the pizza oven. An explosion could occur if pizza oven door is closed.
2. Check that all burner control knobs and the cylinder valve are turned to the 'OFF' position.
3. Turn on the fuel supply by slowly rotating the cylinder valve knob counter-clockwise until fully opened.

LIGHTING THE MAIN BURNERS:

LIGHTING INSTRUCTIONS

1. Turn OFF gas burner control valves.
2. Turn ON gas source or tank.
3. Open lid during lighting.
4. To ignite, turn ignition burner knob to HIGH.
5. Push and hold ELECTRONIC IGNITION button.
6. If ignition does NOT occur in 5 seconds, turn the burner controls off, wait 5 minutes and repeat the lighting procedure.

MATCH LIGHTING THE MAIN BURNERS:

1. Open door before lighting.
2. Make sure both control knobs are in the 'OFF' position.
3. Place a paper match in the end of the match lighter. Strike the match and place through cooking grid to approximately 1/2" (1 to 2cm) from the burner.
4. Turn on the control knob to the 'HI' position. The burner should light within 5 seconds.
5. If burner does not light, turn the control knob to 'OFF' and wait 5 minutes for gas to dissipate and repeat lighting procedure.
6. To light the other burner, repeat 3 & 4.
7. If the burner does not light within the first few attempts of match lighting, there is a problem with the gas supply. Turn off the gas at the burner and cylinder. DO NOT attempt to operate the pizza oven until the problem is found and corrected.

Note: Observe flame height when lit: Flame should be a Blue/Yellow color between 1" - 2" when burner is on 'HI'.

TURNING OFF THE PIZZA OVEN:

1. Turn off the cylinder valve.
2. Turn both burner control knobs to the 'OFF' position.

Note: Turn off LP cylinder first to prevent gas from being left in the system under pressure.

⚠ CAUTION: The cylinder valve should always be in the off (or closed) position when the pizza oven is not in use.

PROPER CARE & MAINTENANCE:

⚠ WARNING:

If a bristle brush is used to clean any of the cooking surfaces, ensure no loose bristles remain on the cooking surfaces prior to pizza oven as loose bristles may attach to food.

CLEANING INTERIOR OF PIZZA OVEN:

■ We recommend cleaning off food residue immediately after cooking by gently scrubbing grates with wire bristle brush and then turning burners to HI for approximately 5 minutes.

⚠ WARNING:

DO NOT leave pizza oven unattended when pizza oven is on. Wear oven mitts to protect from burns.

■ The heat from the burners will burn off most food/grease residue from grates and heat tents and turn it to an ash like substance which will fall to the bottom of the firebox or grease tray. After the pizza oven cools (approximately 30 minutes) remove grates and heat tents and brush the ash and any grease out of the firebox. Clean and replace grease cup. Inspect the heat tents for damage or deterioration before reinstalling in the pizza oven.

■ Wash the grates and heat tents with a mild detergent and rinse with hot water periodically if desired.

⚠ CAUTION:

DO NOT allow ash residue to remain on the grease cup or firebox as it could block proper grease drainage of the pizza oven.

INTERIOR OF PIZZA OVEN DOOR:

■ Smoke will accumulate inside pizza oven door and may flake onto your food. Clean the inside of the pizza oven door with scrub brush and baking soda/water solution. Dry thoroughly. Do not mistake this for paint. The interior of gas pizza oven door is not painted.

MAINTAINING EXTERIOR OF PIZZA OVEN:

- To protect your pizza oven from excessive rust, the unit must be kept clean and covered at all times when not in use.
- Painted surfaces. Wash with mild detergent or non-abrasive cleaner and warm soapy water.
- Stainless steel surfaces. To maintain your pizza oven's appearance, wash with mild detergent and warm soapy water and wipe dry with a soft cloth after each use. Baked-on grease deposits may require the use of an abrasive plastic cleaning pad. Use only in the direction of the brushed finish to avoid damage. Do not use abrasive pad on areas with graphics. Car wax may help protect the exterior finish of your pizza oven.
- Porcelain surfaces. Because of glass-like composition, most residues can be wiped away with a solution of baking soda and water or specially formulated cleaner. Use non-abrasive scouring powder such as baking soda for stubborn stains.
- Plastic and rubber parts. Wash with warm soapy water and wipe dry. Do not use citrisol, abrasive cleaners, degreasers or a concentrated pizza oven cleaner on plastic parts. Damage to and failure of parts can result.

RUST:

- Discoloration, rust and rust pits can occur as a result of high cooking temperatures, acidic marinades, grease fires and exposure to coastal climates or other natural elements.
- Rust spots on the interior surface can be buffed, cleaned, and then lightly coated with vegetable oil or vegetable oil spray to minimize rusting.
- Never use cleaners containing chlorine as chlorine promotes rust.

OPERATING THE PIZZA OVEN:

WARNING

- Read and follow all warnings and instructions contained in the preceding section of this manual.
- Never use charcoal, lava rocks or wood briquettes in a gas pizza oven. Flavoring chips must be contained in a metal smoking box to contain ash and prevent fires.
- DO NOT cover cooking grates or other components with aluminum foil, as this blocks ventilation and damage to bake or personal injury may occur.
- DO NOT leave your pizza oven unattended while 'ON' or in use.
- DO NOT move pizza oven when in use.
- DO NOT use water on a grease fire. Closing the door to extinguish a grease fire is impossible. Use type BC dry chemical fire extinguisher or smother with dirt, sand or baking soda.
- Never cook on the pizza oven without the grease cup in place.

BREAKING IN YOUR PIZZA OVEN:

- In manufacturing and preserving the components of your pizza oven, oil residue may be present on the burners and cooking surfaces of your pizza oven.
- Before cooking on your pizza oven for the first time you should preheat it for 15 minutes on 'HI' to burn off these residual oils.

PREHEATING THE PIZZA OVEN:

- Prior to each use, it is recommended that you preheat your pizza oven. This ensures that the baking surfaces are at the desired temperatures to sear the food sugars when cooking. After lighting your pizza oven, set the main burner control knob to 'HI' position for 5 to 10 minutes. Close the lid when preheating.

CONTROLLING FLARE-UPS/GREASE FIRES:

- Flare-ups are a part of cooking meats on a gas pizza oven. This adds to the unique flavor of cooking on a gas pizza oven. Use caution when opening the door as sudden flare-ups may occur. Excessive flare-ups can over-cook your food and cause a dangerous situation for you and your pizza oven. Excessive flare-ups result from the build-up of grease in your pizza oven. If this should occur, DO NOT pour water onto the flames. This can cause the grease to splatter and could result in serious burns or bodily harm.
- If grease fire occurs while door is open, leave door open, turn burner knobs to 'OFF', turn off LP cylinder valve. If possible, relocate food to a different section and allow grease to burn out or smother the flames with baking soda.
- If grease fire occurs while door is closed, leave door closed, as a sudden burst of air may increase flames. Turn burner knobs to 'OFF', turn off LP cylinder valve. Allow grease to burn out.
- Never pour water on a grease fire as grease may splatter/spread and could result in bodily injury or property damage.
- If grease fire does not quickly burn out or the fire is growing/spreading, use a type BC dry chemical fire extinguisher or smother with dirt, sand or baking soda. Closing the lid to extinguish a grease fire is not possible.

TO MINIMIZE FLARE-UPS:

- Trim excess fat from meats prior to cooking.
- Cook meats with high fat contents (chicken or pork) on Low settings or indirectly.
- Ensure that your pizza oven on level ground and the grease is allowed to evacuate the pizza oven through the drain hole in the bottom and into grease cup.
- Clean pizza oven frequently to minimize grease buildup.

INDIRECT COOKING:

- Indirect cooking is the process of cooking your food without the heat source being directly under you food. You can sear meats over a high flame on one side of the pizza oven while slow cooking a roast on the other (unlit) side of the pizza oven.

BURNER CLEANING AND MAINTENANCE:

- Keep the appliance free and clear of combustible materials, gasoline and other flammable vapors and liquids.
- Keep the ventilation openings of cylinder enclosure free and clear of debris.
- Visually check burner flames for proper operation (see pictorial in 'Burner Assembly/Maintenance' under Proper Care and Maintenance). Spiders or other insects can nest in the burner causing gas blockage.
- For safe baking and peak performance of your pizza oven, perform these checks at least twice per year or after extended periods of storage.
- Be sure to tighten up all hardware (nuts, bolts, screws, etc.) at least twice per year.

⚠ CAUTION:

Some parts may contain sharp edges. Wear protective gloves if necessary.

- Remove the cooking grid, heat tents, and burners from your pizza oven. Use a brush with hot water and detergent to remove excess residue. NEVER use a commercial oven cleaner. Rinse completely with water. Towel dry and replace all components as described in the assembly instructions.

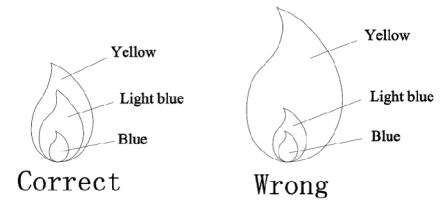

BURNER ASSEMBLY/MAINTENANCE:

- Although your burners are constructed of stainless steel, they may corrode as a result of the extreme heat and acids from cooking foods. Regularly inspect the burners for cracks, abnormal holes, and other signs of corrosion damage. If found, replace the burner.
- DO NOT block ventilation areas in sides, back or cart compartment of pizza oven. Burner tubes can become blocked by spiders and other insects building their nests. Blocked burner tubes can prevent gas flow to the burners and could result in a burner tube fire or fire beneath the pizza oven. To clean the Burner Assembly follow these instructions to clean and/or replace parts of burner assembly or if you have trouble igniting the pizza oven.

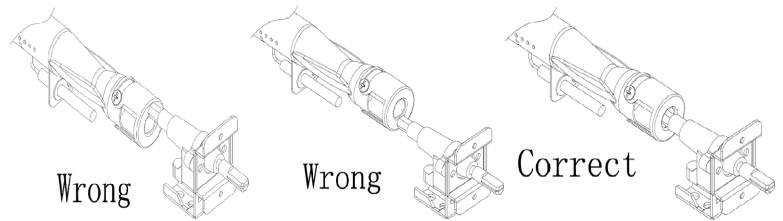

1. Turn gas off at control knob and LP cylinder tank valve.
2. Remove pizza oven door heat tent.
3. Remove bolt from each burner using screwdriver.
4. Carefully lift each burner up and away from valve openings.
5. Use a narrow bottle brush or a stiff wire bent into a small hook to run through each burner tube or use compressed air to blow into burner tube and out the flame ports. Check each port to make sure air comes out each hole.

⚠ CAUTION: Wear eye protection when using compressed air.

1. Use a wire brush to clean the entire outer surface of burner to remove food residue and dirt.
2. Check burner for damage, if any cracks or holes are found replace burner.
8. Install burners in pizza oven and carefully orient burners correctly.

IMPORTANT: Burner opening must slide over valve nozzle.

9. Replace bolts and nuts to each burner and crossover channel.

Note: Follow the 'Gas Leak Testing' section of this manual.

Relight burners to verify proper operation.

10. Replace heat tents and pizza stones.

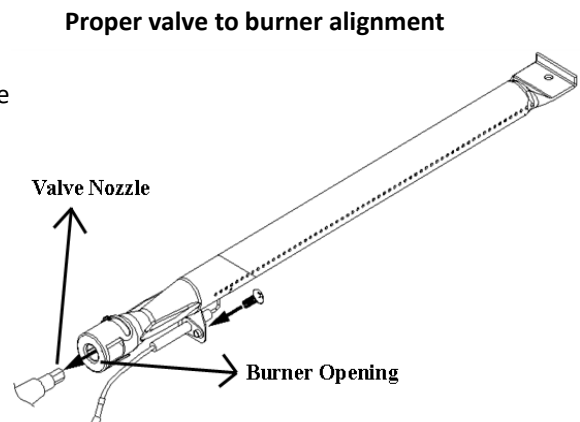

⚠ WARNING: DO NOT attempt to adjust burner air shutter until pizza oven has cooled down for approximately 30 minutes. Failure to do so could cause severe burns.

BURNER ADJUSTMENT:

- Normal flame should be soft blue with yellow tips between 1"-2" when burner is on 'HI'. Depending on elevation, burner air shutter may need to be adjusted to obtain correct air to fuel ratio.

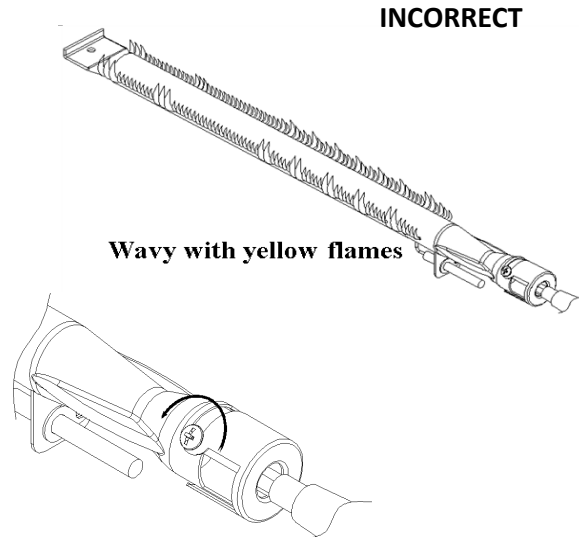
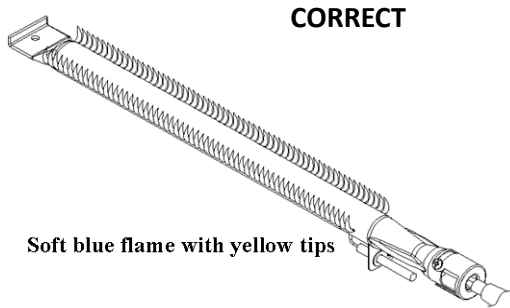

- To adjust air shutter, loosen set screw and rotate air shutter to desired position to achieve normal flame. Tighten set screw after adjustment is made. Relight the pizza oven to observe flame. Incremental adjustments may be needed to achieve a good Flame.

TRANSPORTING AND STORAGE:

⚠ WARNING

- ◆ Never move a pizza oven when hot or in use.
- ◆ Make sure that cylinder valve is closed and burner knobs are in the off position.
- ◆ DO NOT store a spare LP gas cylinder (filled or empty) under or near the pizza oven.
- ◆ Never store flammable liquids or spray canisters under or near the pizza oven.
- ◆ If the outdoor cooking gas appliance is not in use, the gas must be turned off at the LP gas supply cylinder.
- ◆ Storage of an outdoor cooking gas appliance indoors is permissible only if the cylinder is disconnected and removed from the outdoor cooking gas appliance.
- ◆ Cylinders must not be stored in a building or enclosure, including garages and sheds.
- ◆ Cylinders must be kept out of reach of children.

BEFORE STORING YOUR PIZZA OVEN:

- Ensure that the cylinder valve is fully closed.
- Clean all surfaces. Lightly coat the burners with cooking oil to prevent excess rusting.
- If storing the pizza oven indoors, disconnect the LP cylinder and leave the LP cylinder outdoors.
- Place a protective cover on the LP cylinder and store in a well-ventilated outdoor area out of direct sunlight.
- Check and clean burner prior to use after storing, at the beginning of baking season or after a period of not being used. Spiders and insects like to build nests in burner tubes (especially during colder months). Blocked burner tubes can prevent gas flow to the burners and could result in a burner tube fire or fire beneath the pizza oven. See 'Burner Assembly/Maintenance' under Proper Care and Maintenance.
- If storing the pizza oven outdoors, protect the pizza oven with a cover.
- Place dust cap on cylinder valve outlet whenever the cylinder is not in use. Only install the type of duct cap on the cylinder valve outlet that is provided with the cylinder valve. Other types of caps or plugs may result in leakage of propane.



WE TRANSFORM A SIMPLE KITCHEN INTO A PRO ONE.
THIS IS WHY WE CARE ABOUT MAKING VERY HIGH PERFORMANCE
RANGES AND HOODS, TO MAKE YOU FEEL LIKE A PRO AND STYLISH COOKER.

DESIGN: LONDON DC - WWW.LONDON-DC.COM

FOR MORE DETAILS AND INFORMATION, PLEASE VISIT OUR WEBSITE WWW.KUCHT.COM