

**Bench - Banc - Banco****IMPORTANT!-IMPORTANT!-IMPORTANTE!**

Please provide Control No. to ensure replacement parts properly fit unit on hand.  
Fournir N° de contrôle pour assurer que les pièces de rechange s'adaptent correctement à l'unité en question.

Favor de proporcionar el numero de control para garantizar que las piezas de reemplazo ajuste correctame su producto.

Name - Nom - Nombre

Address - Adresse - Dirección

City/State/Zip - Ville/Province/Code postal - Ciudad/Estado/Zona Postal

Phone - Téléphone - Teléfono

Email

Reason of replacement - Raison de remplacement - Razón del reemplazo:

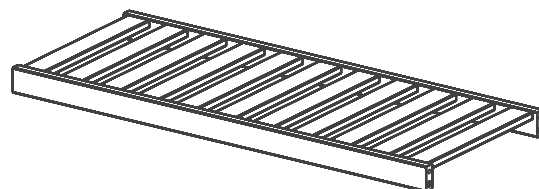
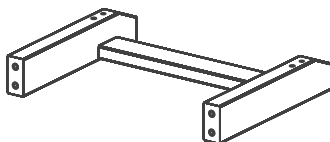
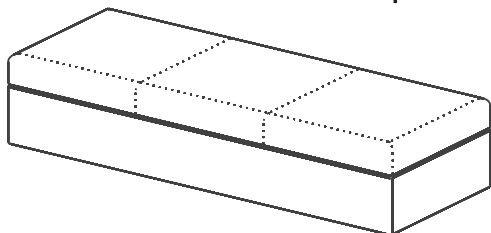
**"Check-list/Part Replacement request" - « Liste de contrôle/Demande de remplacement de pièce »**

<b>A</b>	<i>Cushion</i> <i>Coussin</i> <i>Cojín</i>		
Quantity Quantité Cantidad	1	Missing Manquant Ausente	

<b>B</b>	<i>Side Panel</i> <i>Panneau latéral</i> <i>Panel del costado</i>		
Quantity Quantité Cantidad	2	Missing Manquant Ausente	

<b>C</b>	<i>Shelf</i> <i>Étagère</i> <i>Entrepaño</i>		
Quantity Quantité Cantidad	1	Missing Manquant Ausente	

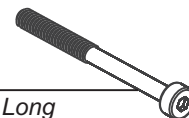
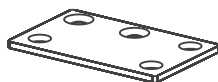
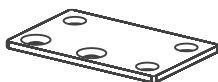



<b>D</b>	<i>Metal bracket - A</i> <i>Suport métallique - A</i> <i>Soporte de metal - A</i>		
Quantity Quantité Cantidad	2	Missing Manquant Ausente	

<b>E</b>	<i>Metal bracket - B</i> <i>Suport métallique - B</i> <i>Soporte de metal - B</i>		
Quantity Quantité Cantidad	2	Missing Manquant Ausente	

<b>F</b>	<i>Wood Dowel</i> <i>Goujon en bois</i> <i>Clavija de madera</i>		
Quantity Quantité Cantidad	4	Missing Manquant Ausente	

<b>G</b>	<i>Bolt - Long</i> <i>Boulon - Longs</i> <i>Tornillo - Larga</i>		
Quantity Quantité Cantidad	4	Missing Manquant Ausente	

<b>H</b>	<i>Bolt - Short</i> <i>Boulon - Courte</i> <i>Tornillo - Corto</i>		
Quantity Quantité Cantidad	20	Missing Manquant Ausente	

<b>I</b>	<i>Wood Plug</i> <i>Bouchon en bois</i> <i>Tapón de madera</i>		
Quantity Quantité Cantidad	4	Missing Manquant Ausente	

	<i>Hex Wrench</i> <i>Clé Hexagonale</i> <i>Llave Hexagonal</i>		
Quantity Quantité Cantidad	1	Missing Manquant Ausente	

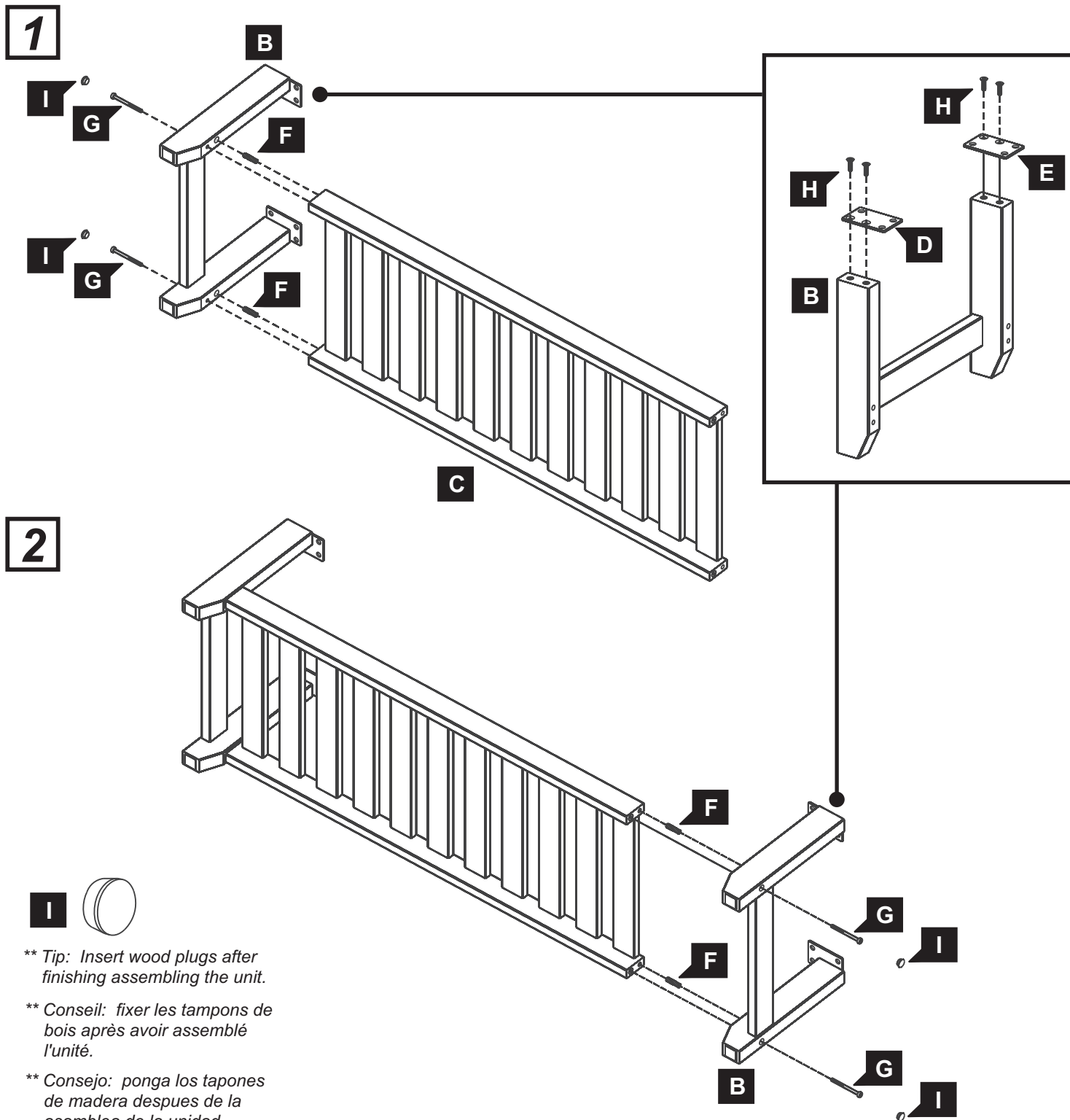
**Assembly Instructions - Instructions d'assemblage - Instrucciones de ensamblaje**

**Care instructions:** To clean, wipe with wet cloth and dry thoroughly. Use mild soap if necessary. Avoid use of commercial waxes or polishes or abrasive cleaning materials.

**Instructions d'entretien:** Pour nettoyer, essuyez avec un linge humide et séchez à fond. Utilisez un savon doux au besoin. Évitez d'utiliser des cires ou produits à polir de type commercial ou des matériaux de nettoyage abrasifs.

**Instrucciones para el cuidado:** Para limpiar, frótelo con algo húmedo y séquelo bien. Use un jabón suave si es necesario. Evite el uso de ceras o pulidores comerciales o materiales abrasivos.

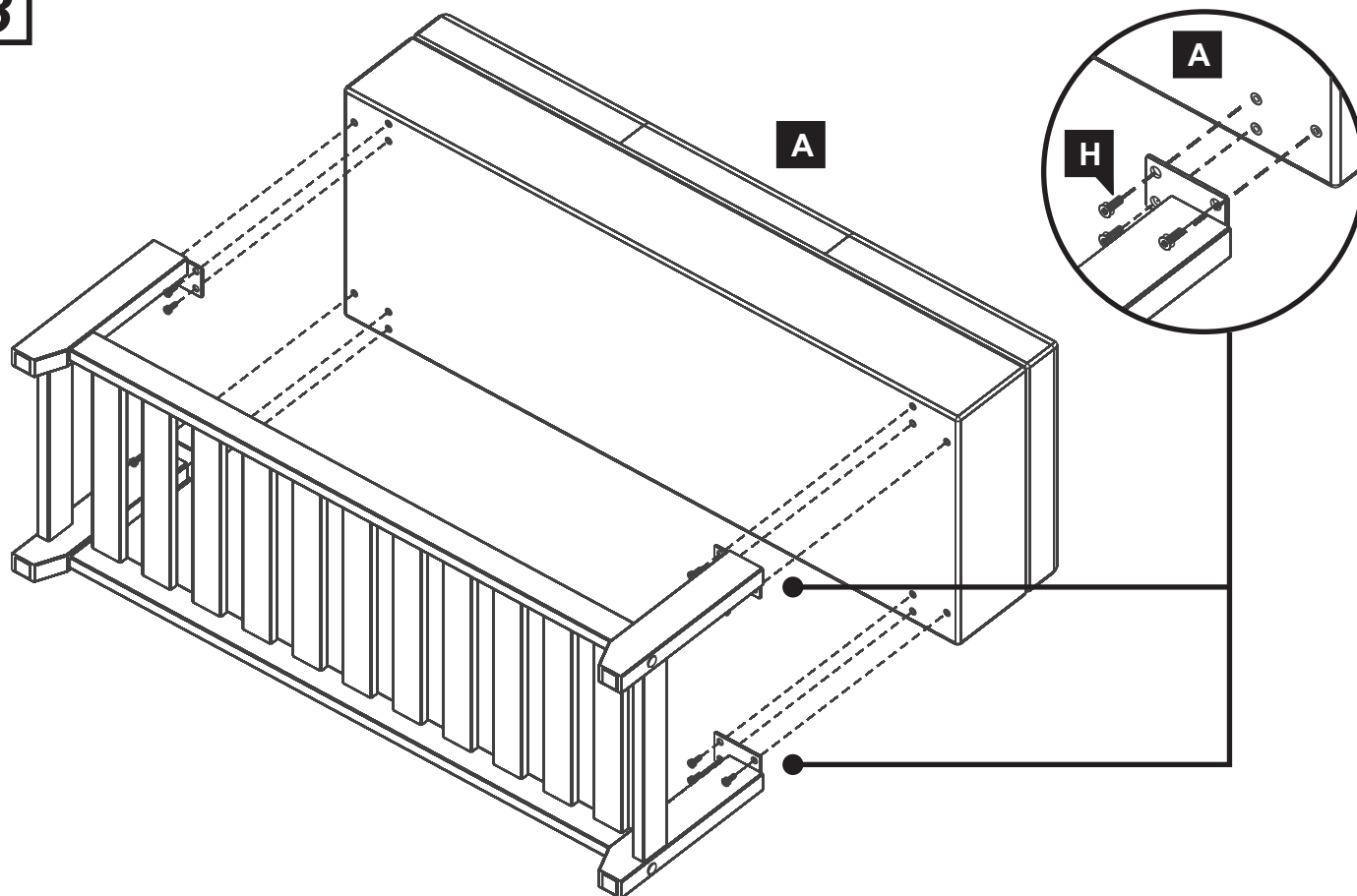
**3****4**