

INSTRUCTION

1008 Awning

Assembly & Care instructions

EN

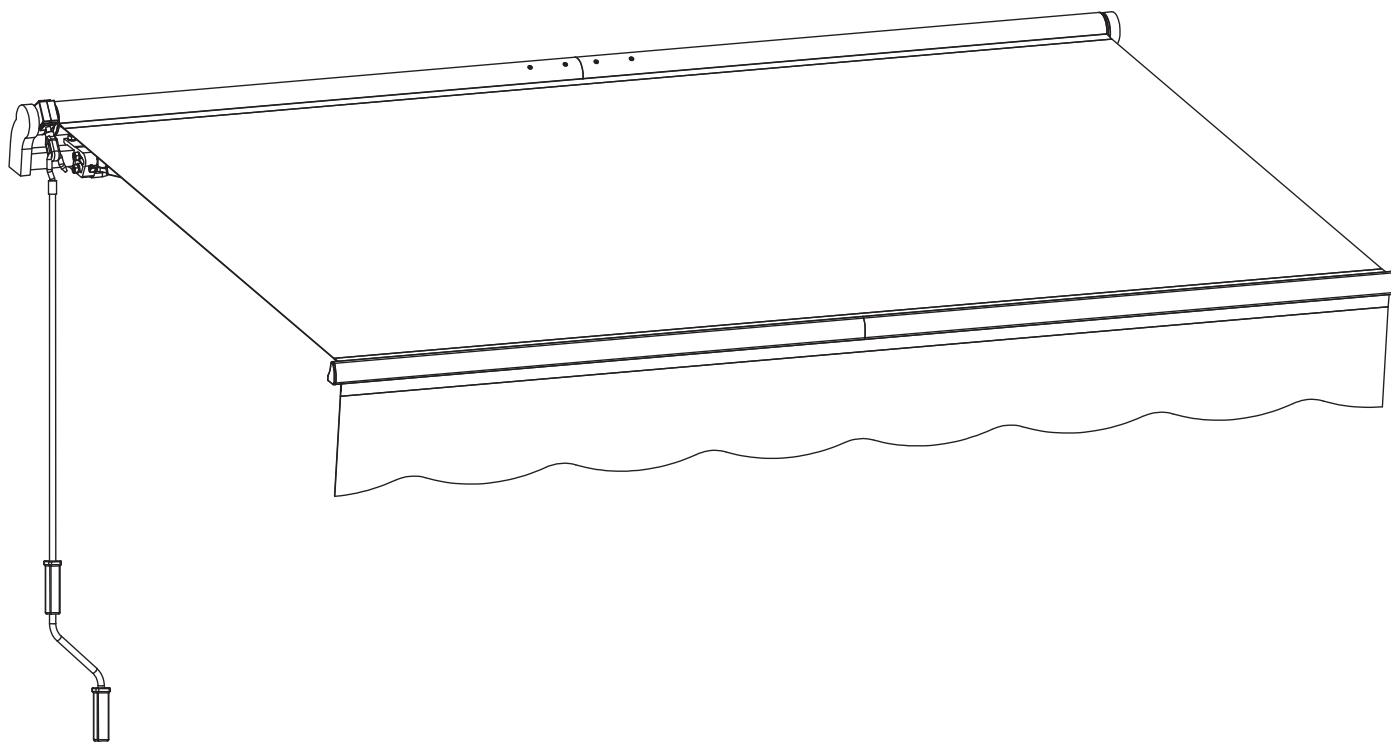

SKU:P25812-D1

IMPORTANT

PLEASE READ BEFORE YOU COMMENCE ASSEMBLY

Follow the guidelines in this user guide to ensure correct assembly and care for this product.

Catalog

Notice 3

Specifications 4

Exploded View 4

Part List 5

Screw Set 6

Extra 6

Installation Steps 7

NOTICE

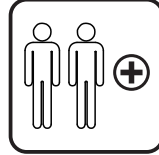
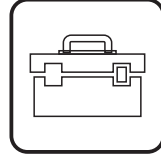
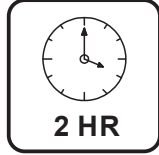
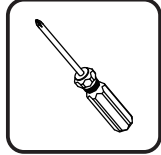
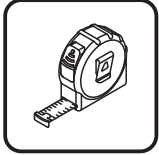
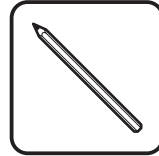
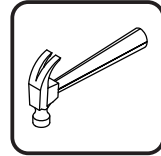
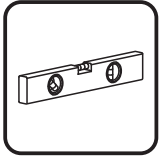

Please verify all parts and components present and check for any damaged pieces before assembly. If you have any damaged or missing parts, please contact customer service at hgeurope@outlook.com.

Contact US:

hgeurope@outlook.com

IMPORTANT

RETAIN FOR FUTURE REFERENCE: READ CAREFULL.

TIPS

PLEASE DO NOT USE IN BAD WEATHER TO AVOID DAMAGE.

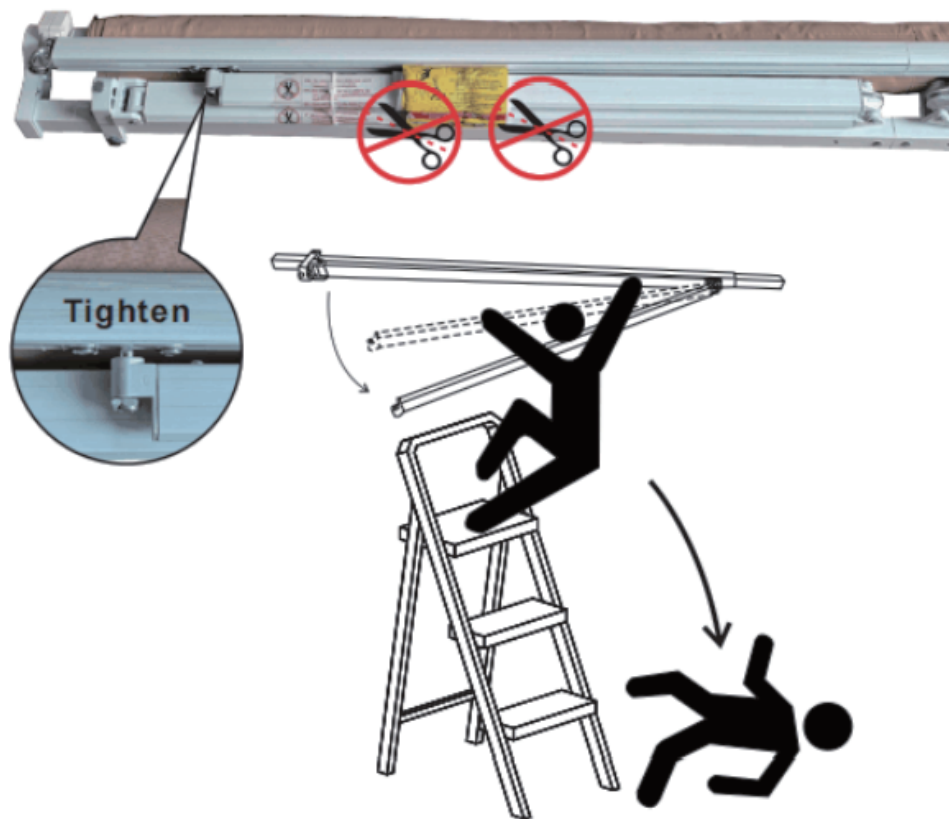

DANGER

CUTTING THE CABLE TIES BEFORE ASSEMBLY MAY CAUSE INJURY.

SPECIFICATIONS

SPECIFICATIONS

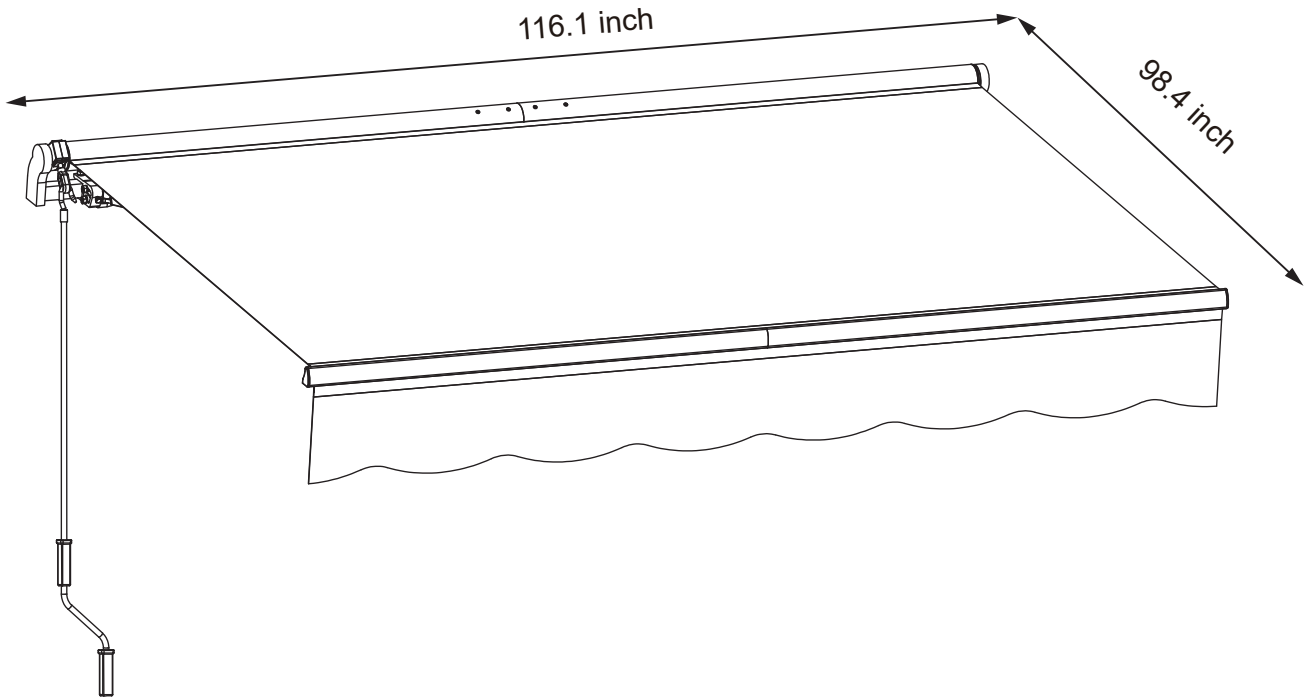





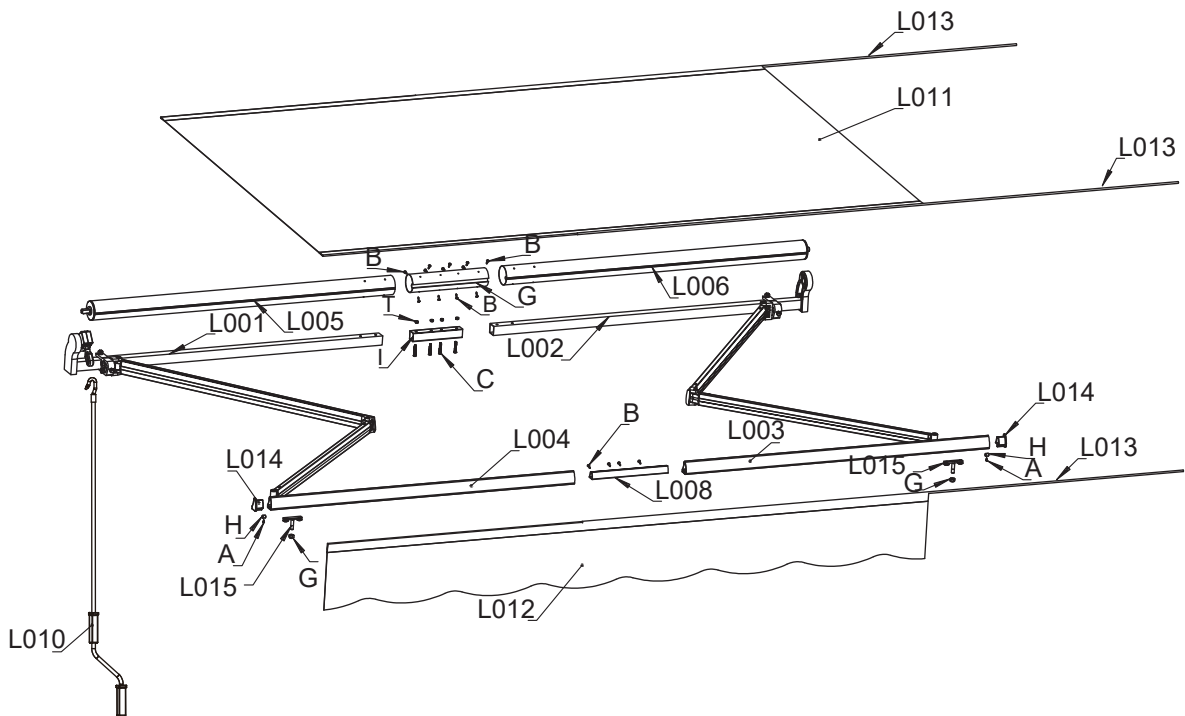



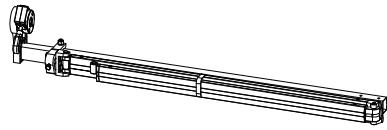
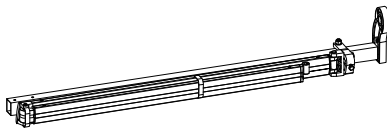

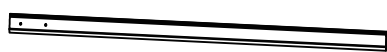
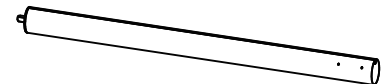
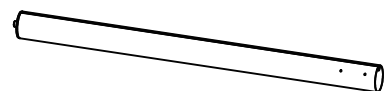
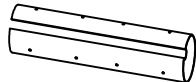
EXPLODED VIEW

EXPLODED VIEW

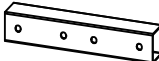

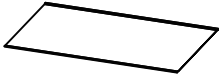

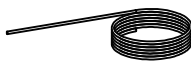

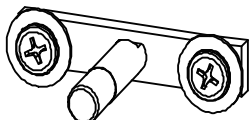
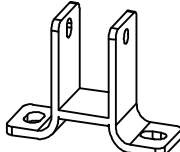

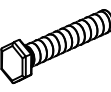

PART LIST

NO.	PART.	Qty.
L001		1
L002		1
L003		1
L004		1
L005		1
L006		1
L007		1
L008		1



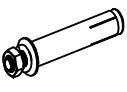

NO.	PART.	Qty.
L009		1
L010		1
L011		1
L012		1
L013		3
L014		2
L015		2
L016		2



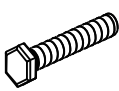

SCREW SET

NO.	PART.	Qty.
A	 ST3*10	2
B	 ST4*15	16
C	 M6*40	4
D	 M8*55	2
E	 M6	4

NO.	PART.	Qty.
F	 M8	2
G	 M10	2
H	 M8	2
I	 M10	4
J	 M8	4

EXTRA

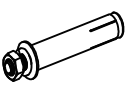
NO.	PART.	Qty.
A	 ST3*10	1
B	 ST4*15	2
C	 M6*40	1
D	 M8*55	1
E	 M6	1

NO.	PART.	Qty.
F	 M8	1
G	 M10	1
H	 M8	1
I	 M10	1
J	 M8	1

INSTALLATION STEPS

Step 1

Thread the fabric Line , and cut the Fabric Line as long as the Fabric.

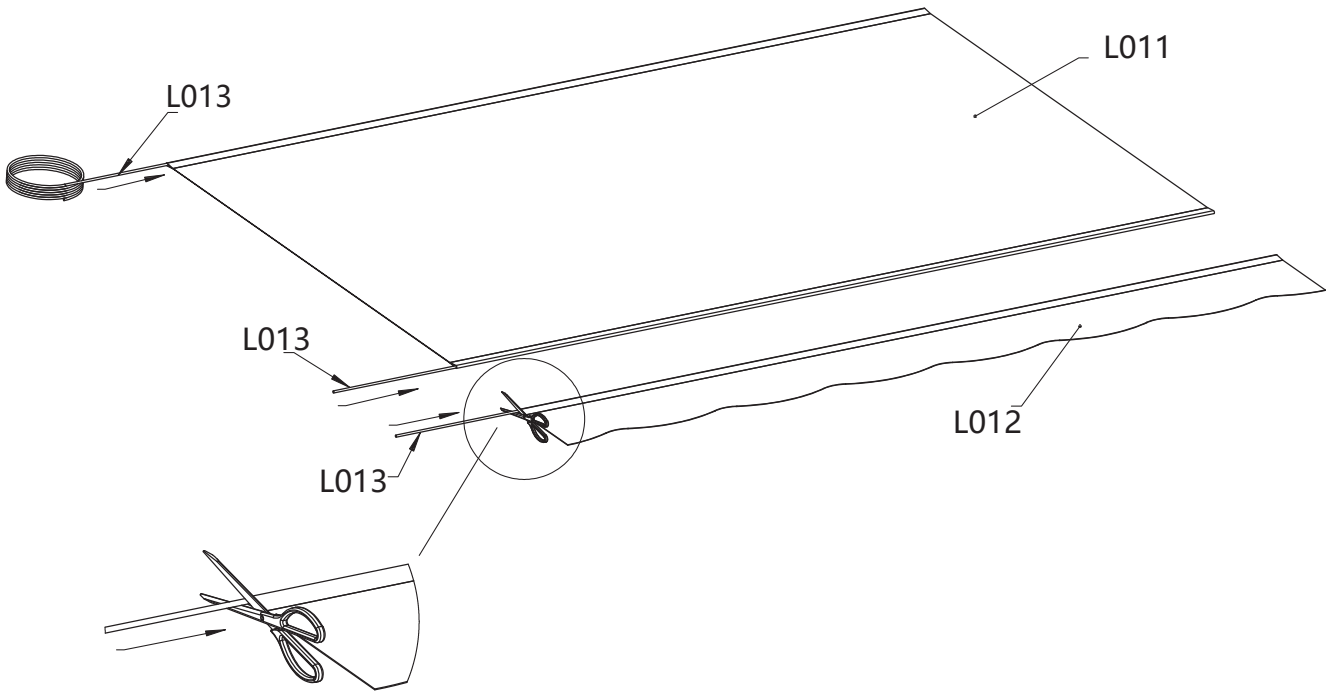

L011 x1



L012 x1



L013 x3

Step 2

Connecting Roller Tube and Front bar (LEFT).

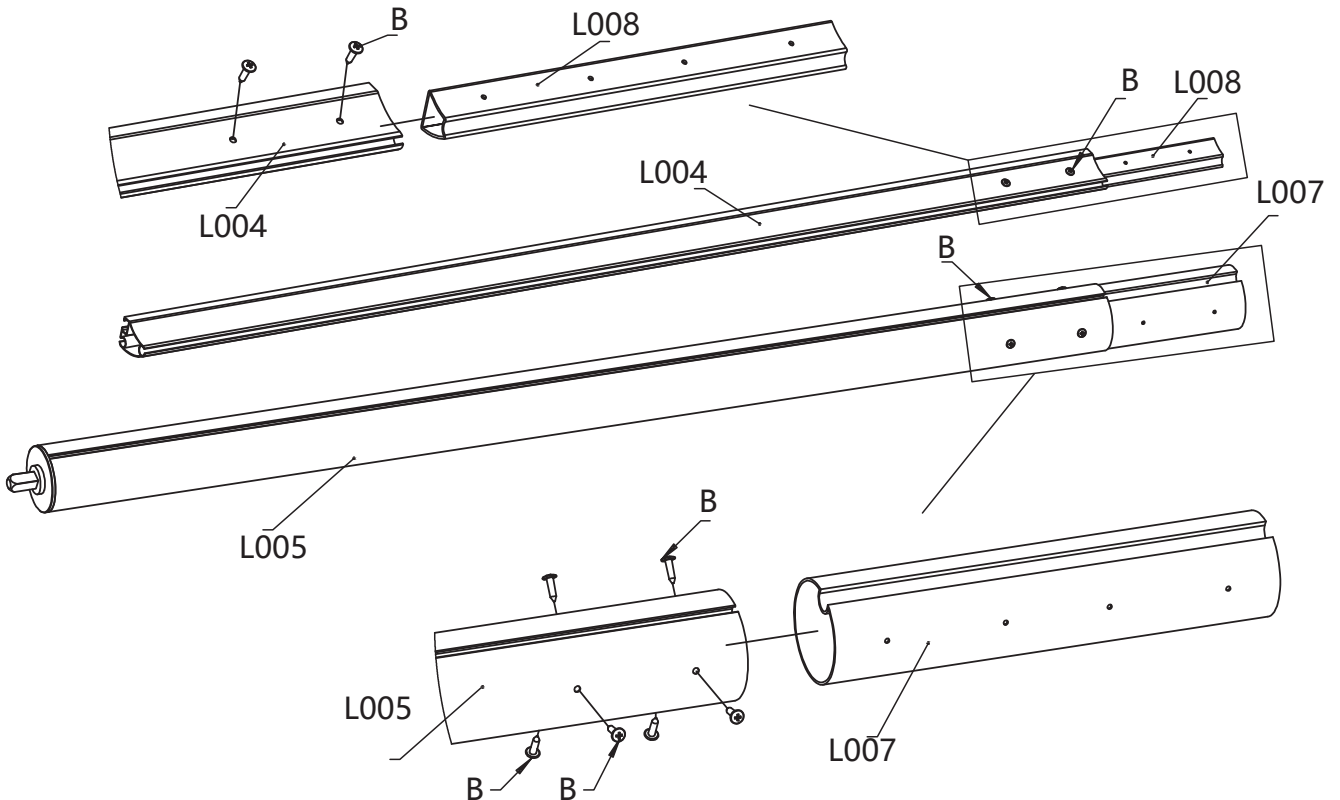

L004 x1



L008 x1



L005 x1



L007 x1



B x8

Step 3 Fabric Assembly and Connecting Roller and Front bar.

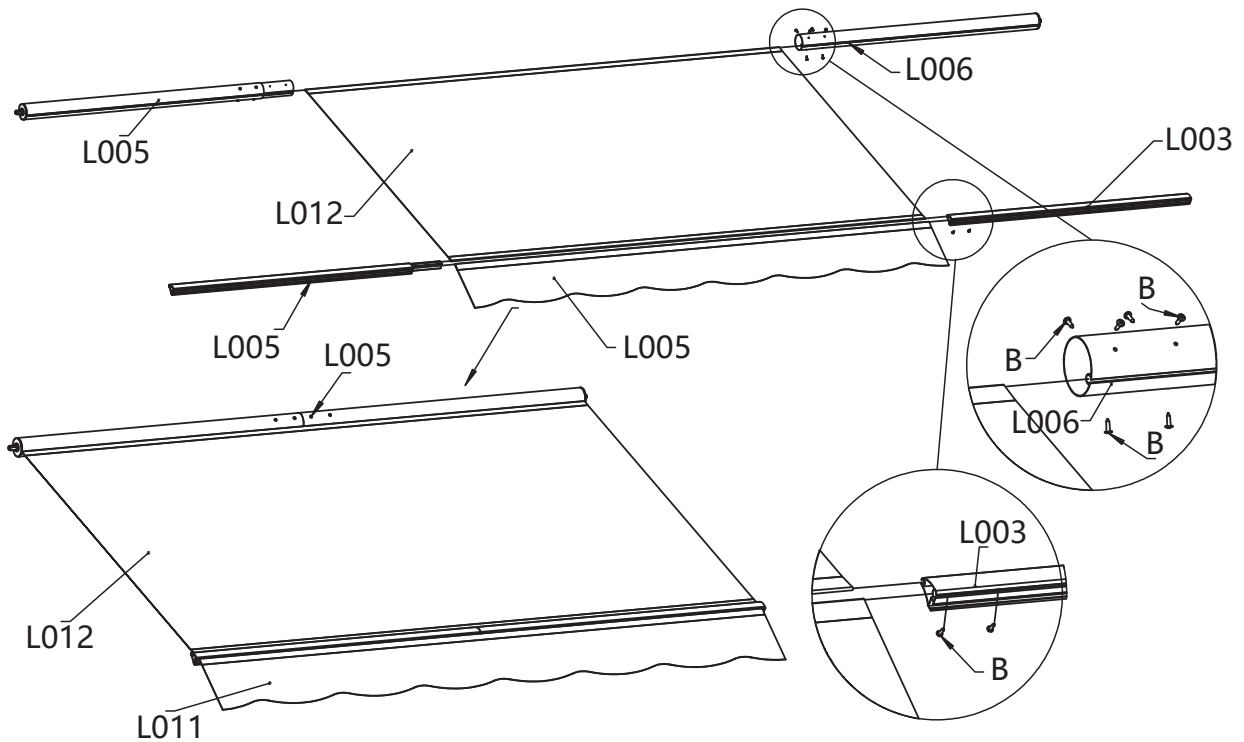

L003 x1



L006 x1



B x8

Step 4

1. Put the Arm-bar Link into the Front bar.
2. Put H part into the Front bar and Lock it with Screw A.
3. Tap the Front bar Caps.

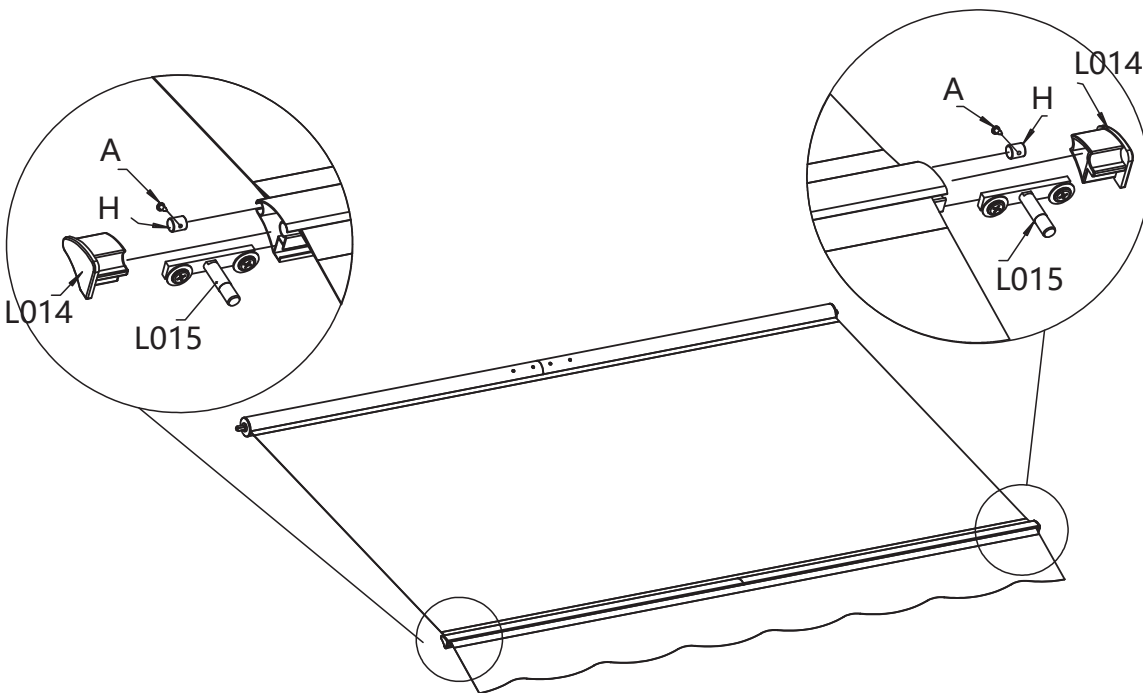

L014 x2

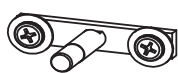

L015 x2

A x2

H x2

Step 5 Roll the awning Fabric as tightly as Possible.

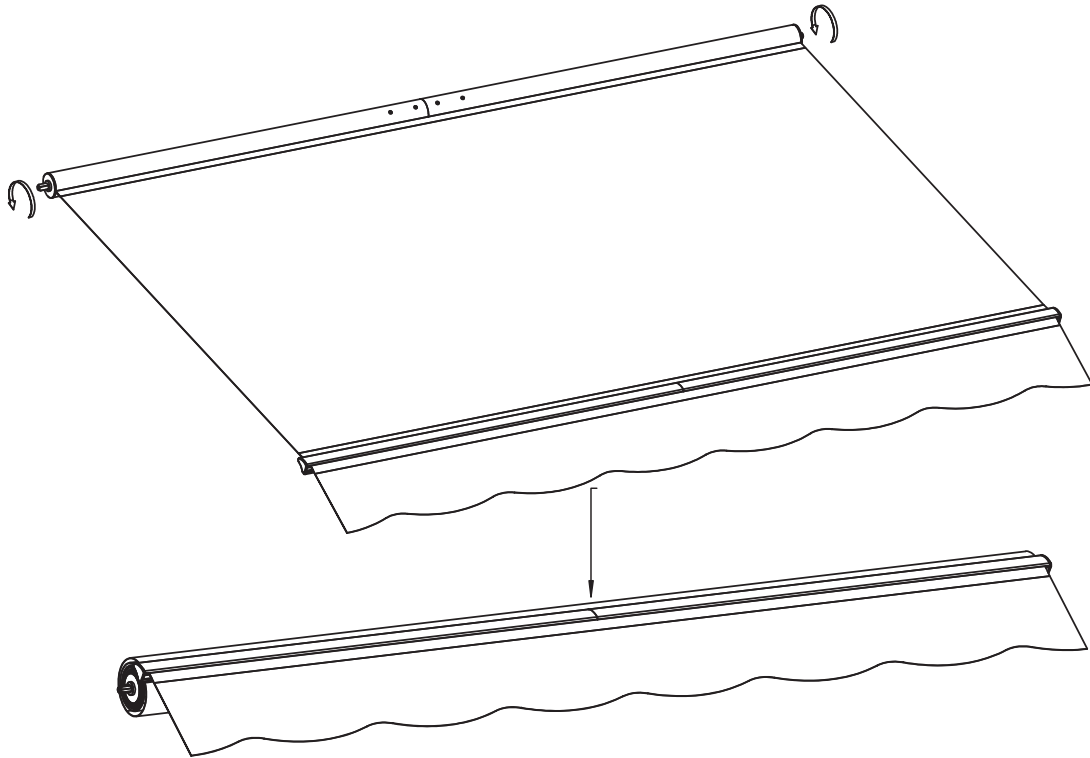

Step 6

1. Connecting the Left Torstion bar(L001 and L009),and The Riaht Torstion bar screwed it later.
- 2.Put the Roller into the Square hole of the gear box and Round of the rooler support,thenpush Left and Right Together.
- 3.Connected and Screwed the Right Torsionbar(L002 and L009).

Insertin

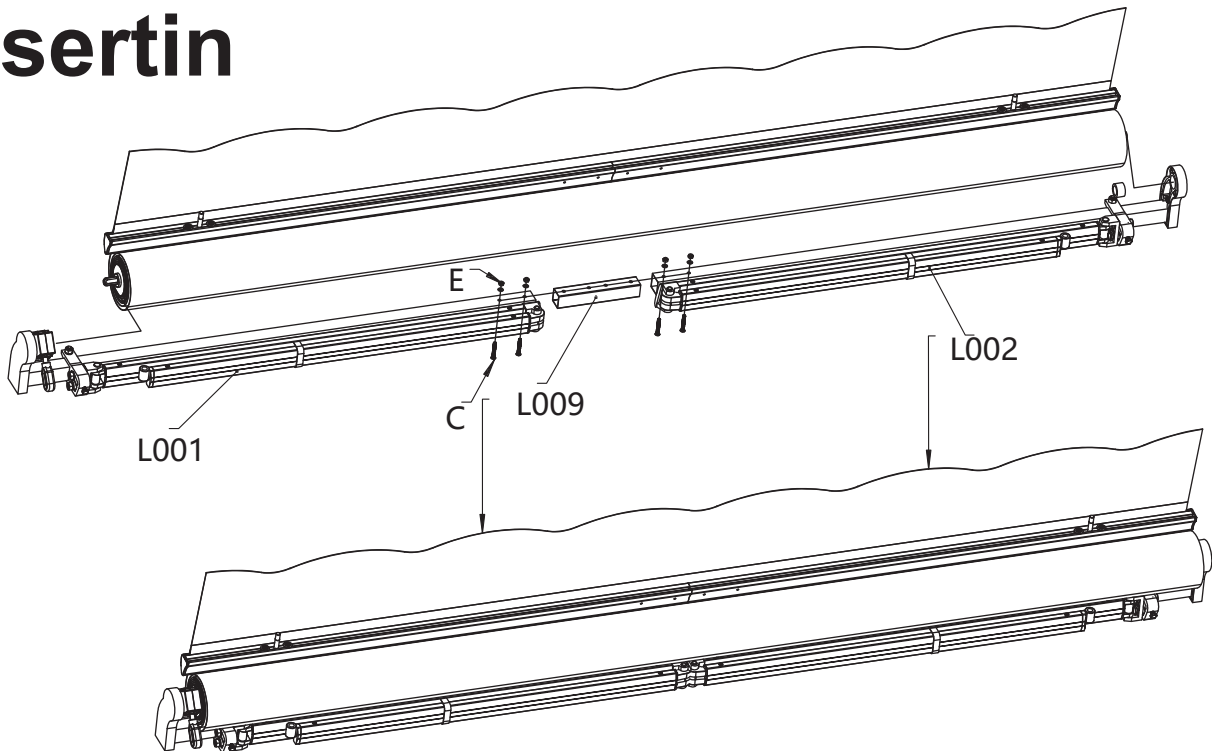

L001 x1



L002 x1

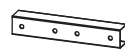

L009 x1



C x4



E x4

Step 7

Setting Awning Position

1. Move the arm-Link until the front bar wrist support is Connected through it.
2. Align the from bar and the arm.and tighten the screw G part.
3. Then tighten G the adjustable bolt up to 90% tight.

Note: The Front bar is Placed flat with the Roller.

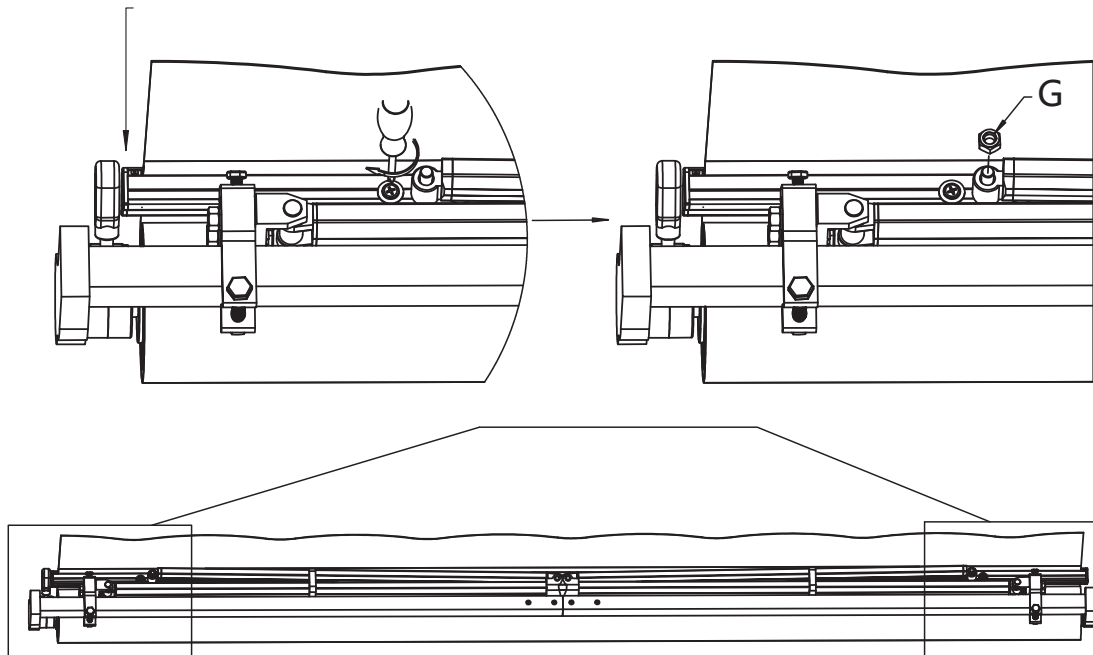

 G x2

Step 8

Finishing Awning Assembly

1. It's safe to cut the safety sleeves that hold the arms and torsion bar down. Awning assembly is complete.
2. Now, Proceed to the wall mounting section.

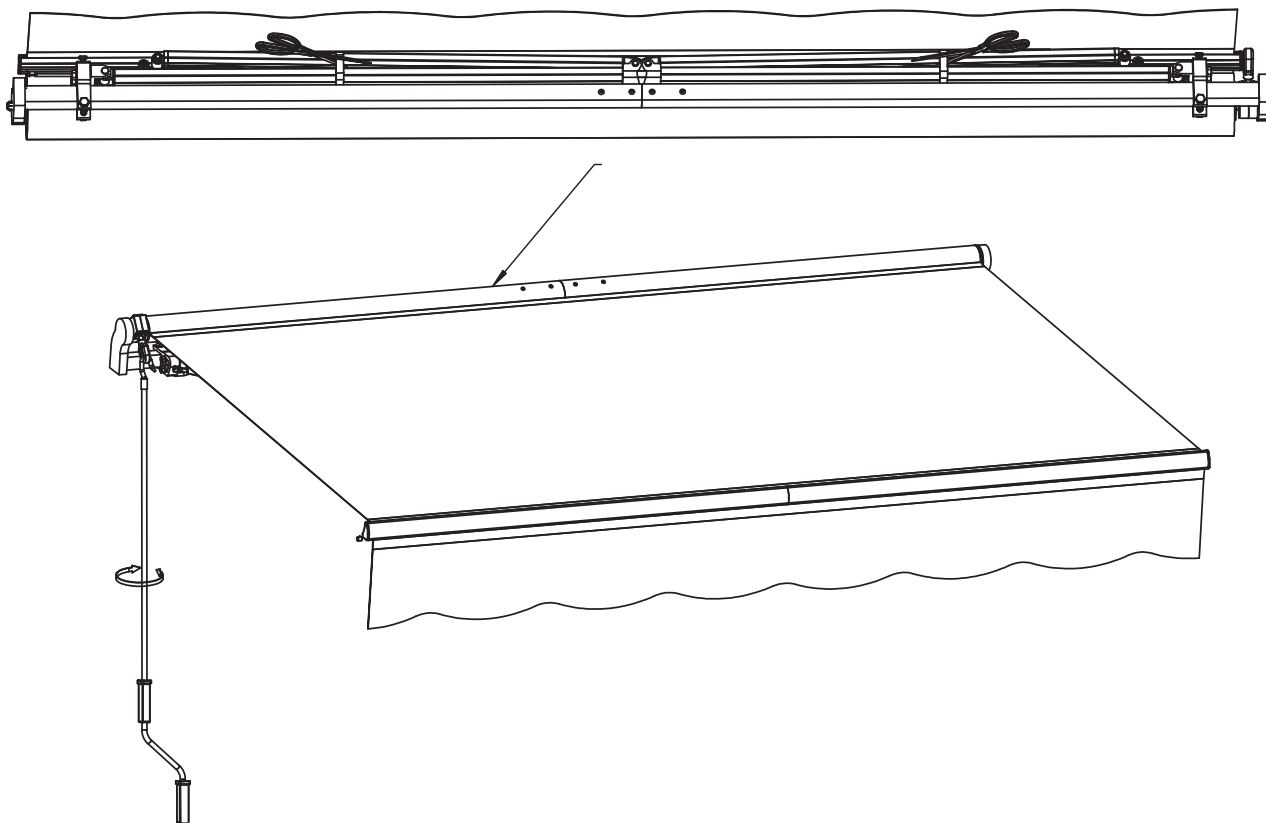

🔧 INSTALLATION

Notes About Wall Mounting

This awning can be secured to reinforced concrete, brick, and wood, however this awning kit only supplies screws suitable for mounting to brick and reinforced concrete walls.

If you wish to secure your awning to wood, please use carriage bolts of adequate length and of an appropriate diameter to secure the awning to wood beams. The bolt size depends on the size of wood; these can be purchased at a hardware store. We recommend a professional installer for the safest and most secure installation.

Never attempt to secure the wall brackets to loose wall stones or any surfaces that are not absolutely firm!



CAUTION: Proper location of the brackets is the most important aspect of the awning installation. It is critical that you fasten all the mounting brackets to studs, joists, headers or other major structural components.



WARNING: Failure to securely fasten all the brackets to the wall could result in the collapse of the awning and cause personal injury or death.

Mounting Height

It is important to take the awning's drop area into consideration before bolting your wall mounts. If you would like to mount above a patio door, for example, please leave at least 8 inches above the door frame and be sure that the awning does not interfere with opening and closing the door. The drop angle can only be changed minimally, so take this into consideration when deciding where to place your awning.

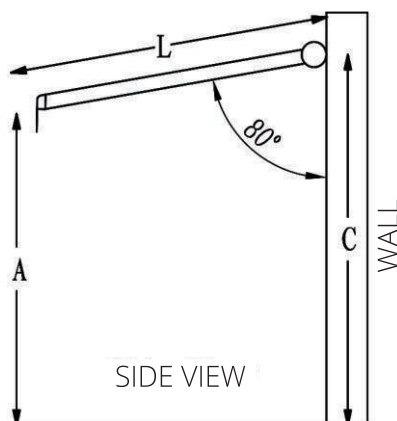

- **Recommended Installation Height:** 8-12 feet.
- **The ideal drop angle (when fully extended) has already been set in the factory**, so you may not have to change the pitch/angle.
- **The awning has a drop** of 24 inches when at a slope, or 15 degrees.

CALCULATIONS:

You can use the following formula to calculate the appropriate angle.

$$C = A + 0.17 * L$$

A = The desired height of the front bar

L = The length of the arm stretched out

C = The height of the wall brackets

We recommend that the awning surface make an angle of about 80 degrees to the wall when open.

STEP 1: Measuring the Mount Site

1. Measure the length of your awning along the wall where you intend to install it. This line will be the highest point of your awning and align with the top of the wall bracket. Use a leveler to make a chalk line across the distance.
2. **Important: double check that the line is level all the way across.**
3. Be sure that the line is centered over the patio door, window, or other feature, if applicable.
4. Now that you have a straight, centered line, measure the middle point and mark it. This is where the middle wall bracket will be installed.
5. Take a wall bracket and place the top of it, completely level, under the line, as shown in the diagram below. With chalk or a pencil, mark the position of all the wall brackets and their bolt holes.

Awnings < 10.8 Feet	Requires only 2 wall brackets total: one for each end of the torsion bars.
Awnings 10.8 - 14 Feet	Requires 3 wall brackets total: one for each end, and one in the middle.
Awnings 14.5 - 20 Feet	Requires 4 wall brackets total: one for each end, and two in the middle.

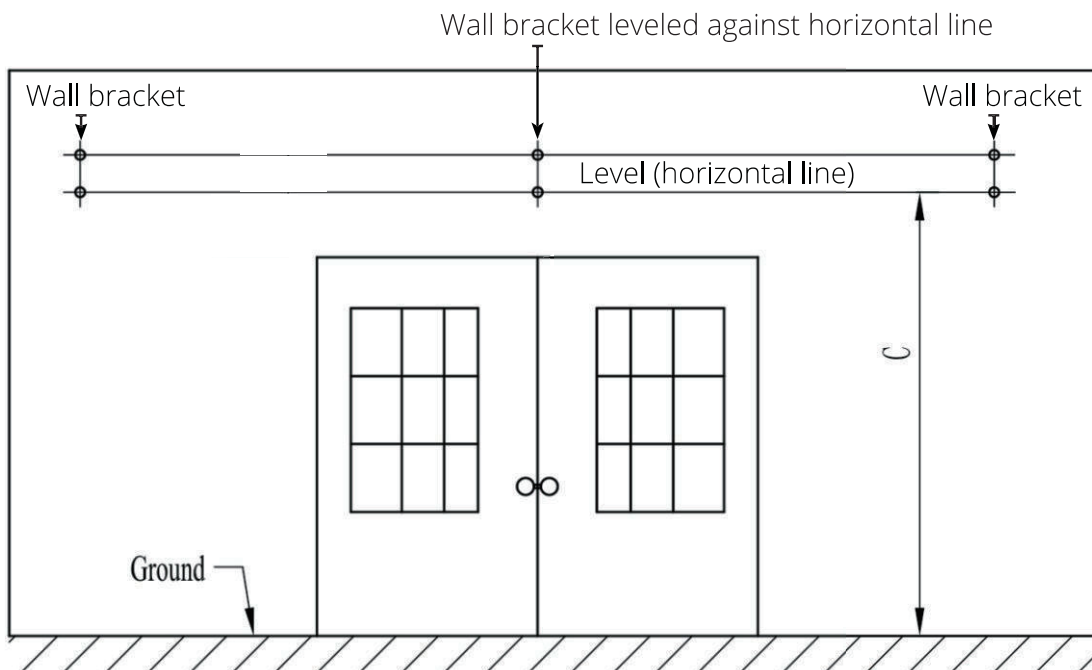

STEP 2: Drilling the Bolt Holes

1. Now that you have a straight, level line across the wall with the locations of the wall brackets and their bolt holes marked, you will drill holes to mount the brackets.
2. Using a 14mm masonry drill bit, drill the first bolt hole approximately 4 inches (9 centimeters) deep, as shown in the diagram. This must be drilled through solid brick or concrete to offer the necessary support for the awning.
3. Drill the remaining holes exactly as in step 2.

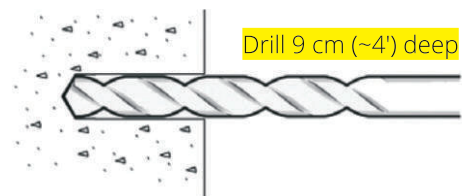

!! IMPORTANT: All bolt holes must be aligned vertically and horizontally to ensure that the awning hangs straight.
Double check alignment before drilling if you are not certain.

!! IMPORTANT: The diameter and depth of your mounting holes must be the same size as the expansion bolts.

STEP 3: Preparing For Mounting

1. Now that all of your holes are drilled, insert the expansion bolts.
2. It may be necessary to drive the bolts in with a wooden (or other non-metallic) mallet.



If a mallet is necessary for installation, we recommend placing the nut on the screw (loosely) before hammering to avoid damaging the bolt threads.

3. Make sure that the bolts are firmly in place, yet let them stick out of the wall approximately 1 inch or less - enough that the wall bracket can be installed onto them.
4. Firmly tighten the bolts with a 19mm hex key. It is best to use the hex key with a closed end rather than an open end to avoid damaging the nut, should it slip.

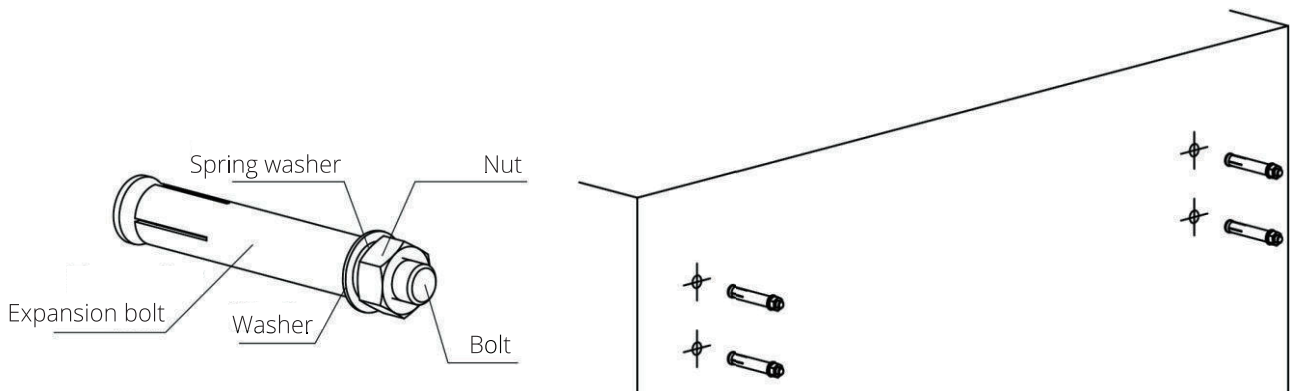

STEP 4: Mounting the Wall Brackets

1. Now that the bolts are securely in the wall, remove the nuts that are loosely placed over the bolts.
2. Place a wall bracket onto one set of bolts. This should be an easy fit if the bolt holes are properly aligned.
3. Once the wall bracket is resting on the bolts, place a washer over the bolt, then secure it with a nut, as shown in the diagram.
4. The **brackets MUST sit firmly on the wall**. If there is any movement, you must tighten it more.
5. Repeat this step for each of the wall brackets. Once you do this, all wall brackets will be securely in place.

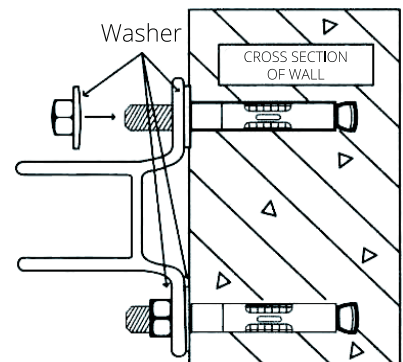

STEP 5: Mounting the Awning

1. Now that the wall brackets are secure and in place, it is time to install the awning onto the brackets.
2. At least two ladders or sturdy chairs are required to install the awning.
3. Put the original expansion bolts on the wall brackets and tighten them.
4. Finally, fasten all expansion bolts.
5. Using the hand crank or a motor (if applicable), fully open your awning. The front bar should be level.
6. **Congratulations! Your awning is installed. If you are happy with the height of the front bar (awning pitch), sit back and enjoy! If not, please read on.**

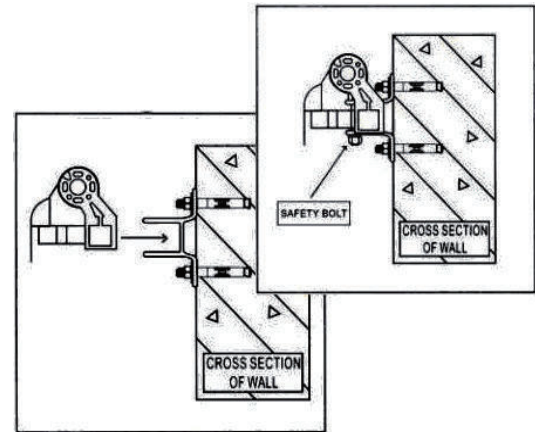

😊 OPTIONAL INSTALLATION

ADJUSTING THE AWNING PITCH/ANGLE

Each awning comes with a pre-set pitch (angle) that is considered ideal. However, if you need to make an adjustment, it can be done in just a few easy steps.

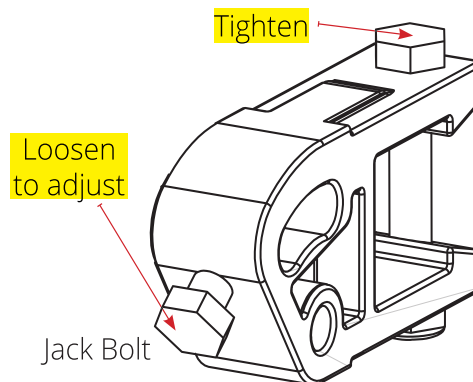
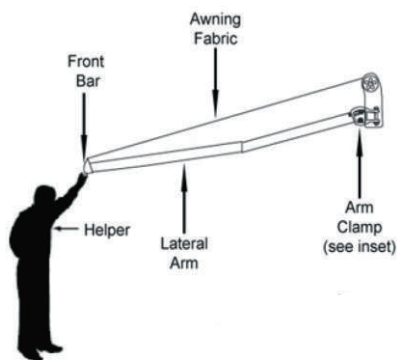

!! IMPORTANT: Raising the front bar will reduce the pitch (angle) of the fabric, thus increasing the risk of rain water pooling on the fabric. To prevent the awning from collapsing due to rain water weight, you must retract the awning when unattended. Failure to do so could result in a broken awning or personal injury.

Note: Be sure that the front bar is adjusted to be completely even. Any misalignment will result in improper retraction.

Common mistakes

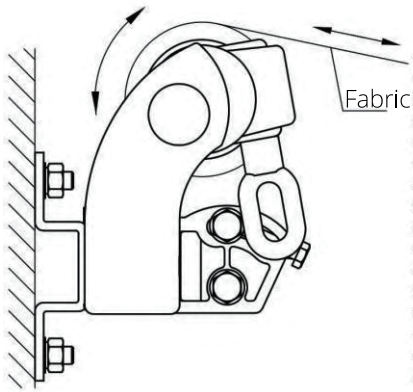

Correct operation

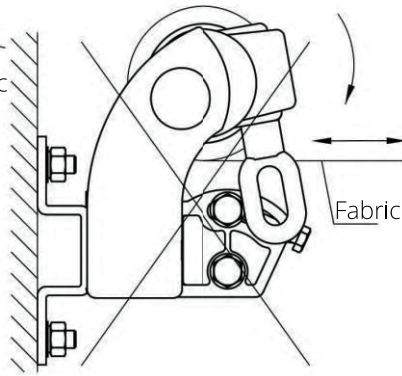

Wrong operation

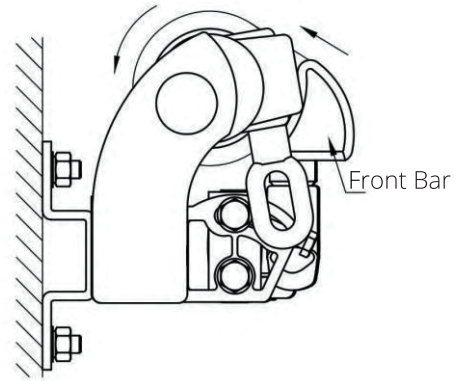

WARNING: When the front bar touches the roller as shown in the figure, don't try to make them closer, otherwise the product may be damaged.

1008 Markise

Instructions de montage et d'entretien

DE

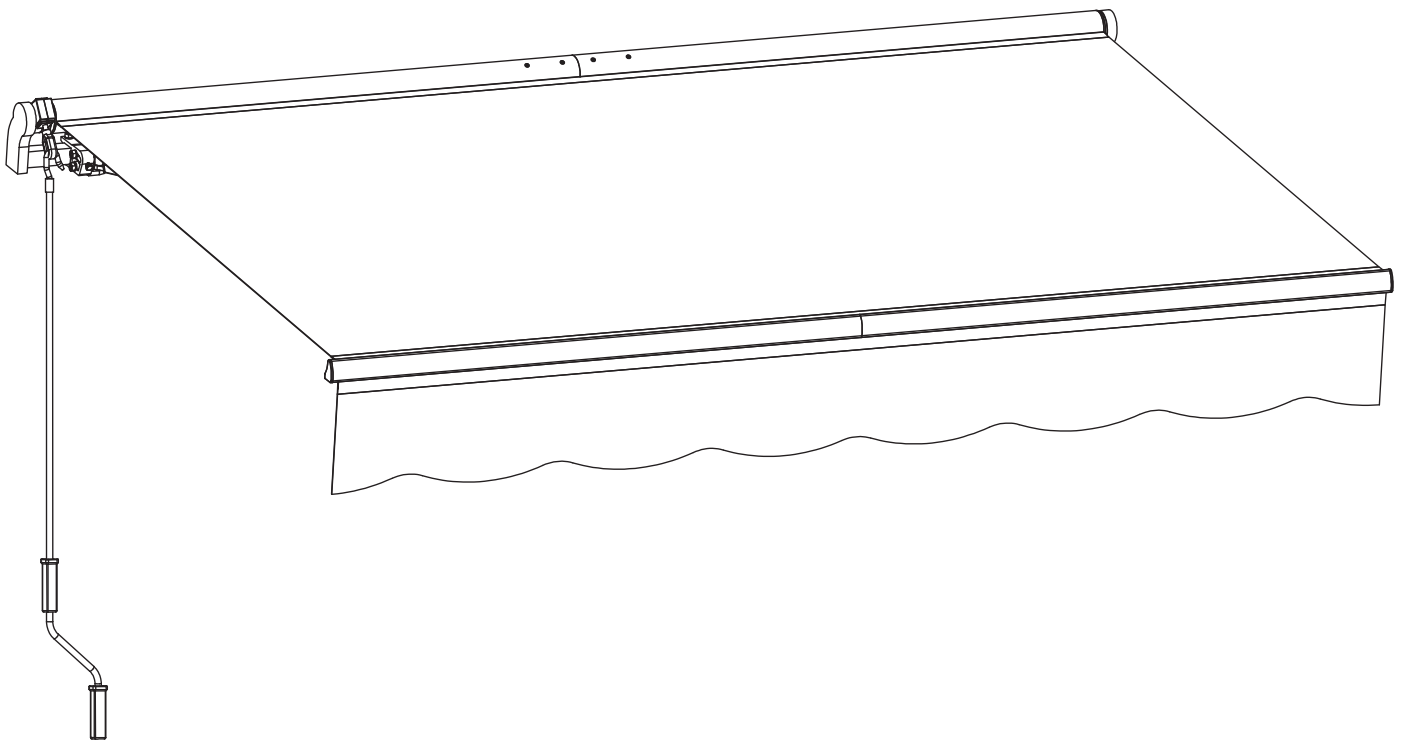

SKU:P25812-D1

WICHTIG

BITTE VOR BEGINN DER MONTAGE LESEN

Befolgen Sie die Anweisungen in dieser Bedienungsanleitung, um eine korrekte Montage und Pflege dieses Produkts sicherzustellen.

Katalog

Hinweis.....	3
Spezifikationen.....	4
Explosionszeichnung.....	4
Teileliste	5
Schraubensatz	6
Extra	6
Installationsschritte	7

HINWEIS

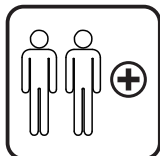
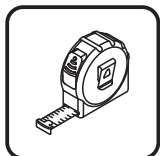
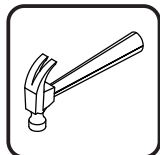
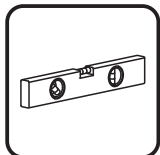

Bitte überprüfen Sie vor dem Zusammenbau, ob alle Teile und Komponenten vorhanden sind, und kontrollieren Sie, ob die Teile beschädigt sind. Wenn Sie beschädigte oder fehlende Teile haben, wenden Sie sich bitte an den Kundendienst unter hgeurope@outlook.com.

Kontakt US:

hgeurope@outlook.com

WICHTIG

FÜR SPÄTERE VERWENDUNG AUFBEWAHREN: SORGFÄLTIG LESEN.

HINWEIS



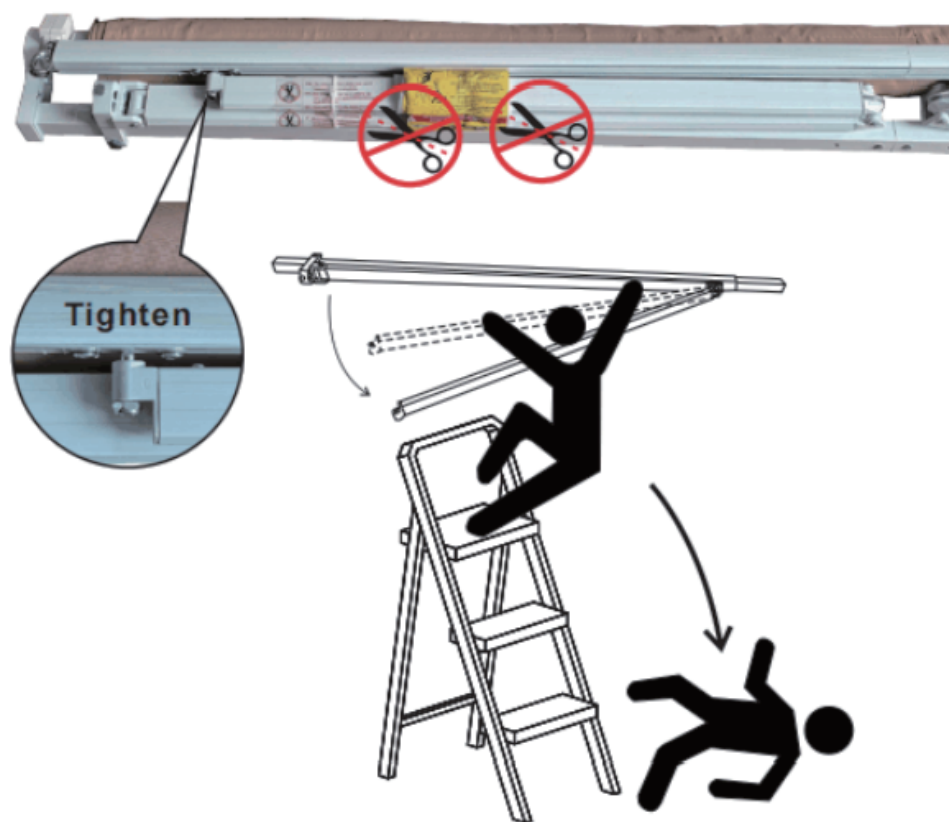

BITTE NICHT BEI SCHLECHTEM WETTER VERWENDEN, UM SCHÄDEN ZU VERMEIDEN.





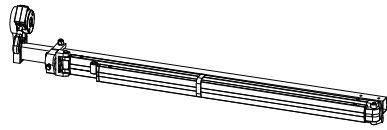
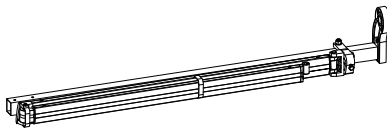

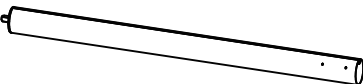
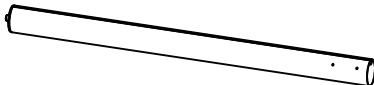
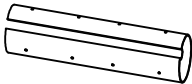

GEFAHR

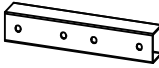

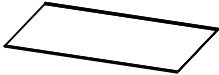

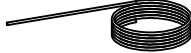
DAS DURCHSCHNEIDEN DER KABELBINDER VOR DER MONTAGE KANN ZU VERLETZUNGEN FÜHREN.

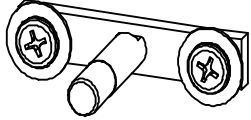
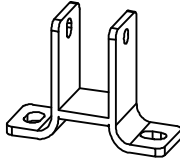

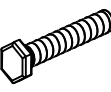

TEILELISTE

Teil	Symbol	Menge
L001		1
L002		1
L003		1
L004		1
L005		1
L006		1
L007		1
L008		1



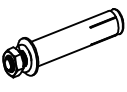

Teil	Symbol	Menge
L009		1
L010		1
L011		1
L012		1
L013		3
L014		2
L015		2
L016		2



SCHRAUBENSATZ

Teil	Symbol	Menge
A	 ST3*10	2
B	 ST4*15	16
C	 M6*40	4
D	 M8*55	2
E	 M6	4

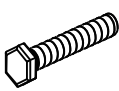
Teil	Symbol	Menge
F	 M8	2
G	 M10	2
H	 2	
I	 4	
J	 4	

EXTRA

Teil	Symbol	Menge
A	 ST3*10	1
B	 ST4*15	2
C	 M6*40	1
D	 M8*55	1
E	 M6	1

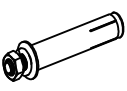
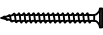
Teil	Symbol	Menge
F	 M8	1
G	 M10	1
H	 1	
I	 1	
J	 1	

Schritt 1 Fädeln Sie die Stofflinie ein und schneiden Sie die Stofflinie so lang wie den Stoff.

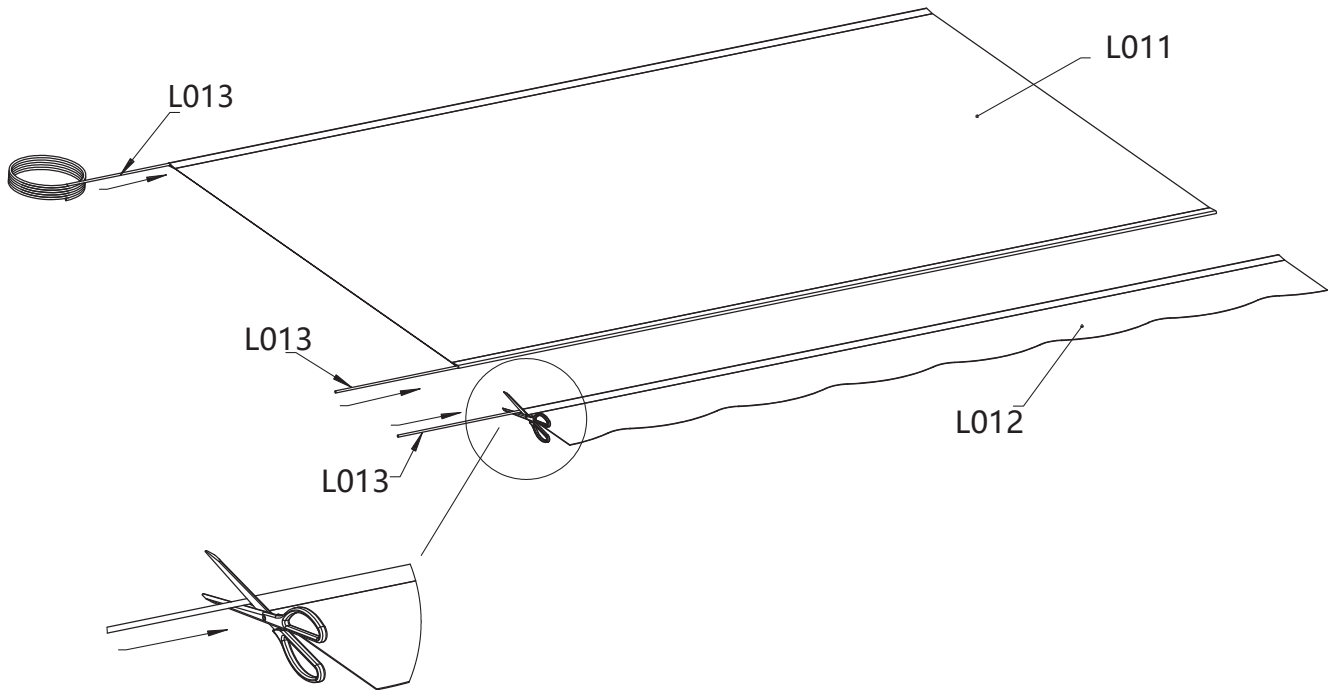

Schritt 2 Verbindung zwischen Rollenrohr und Frontbügel (LINKS).

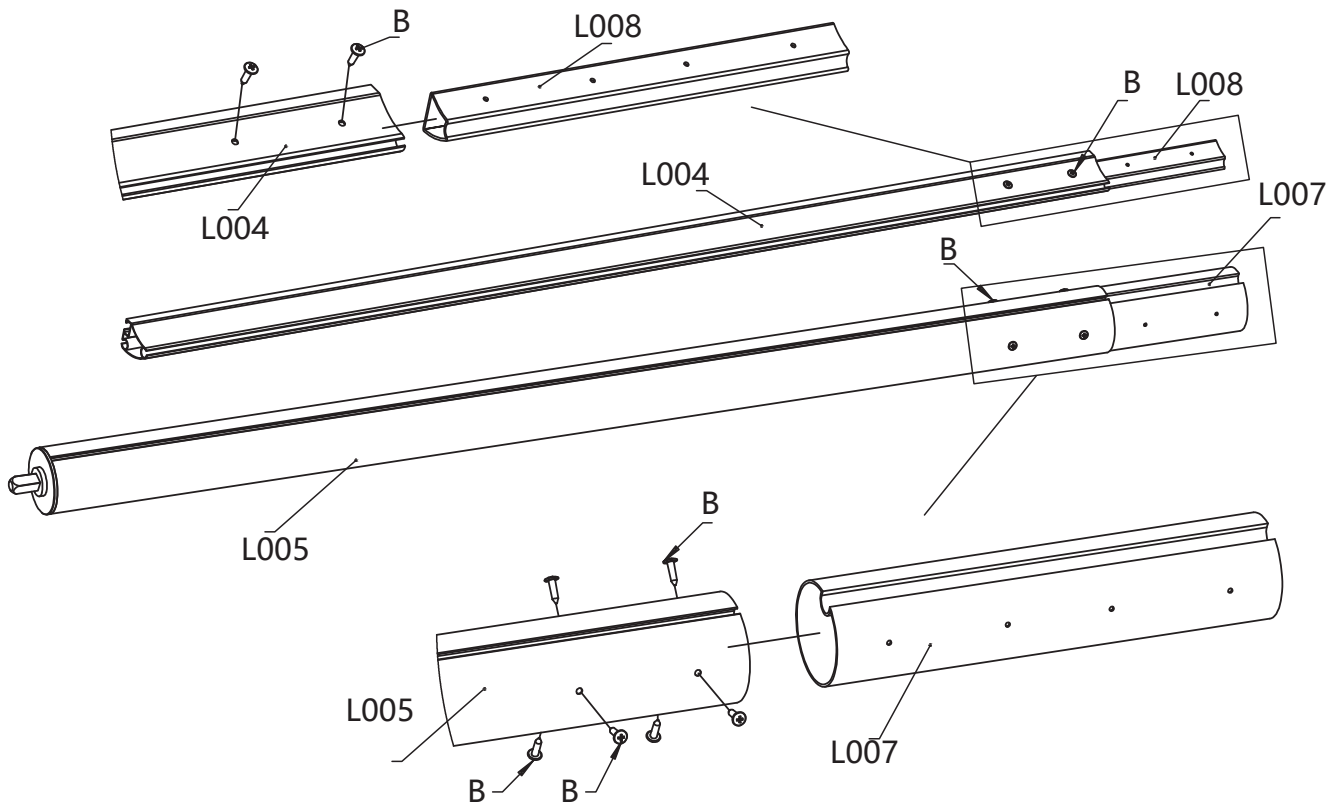

Schritt 3

Montage des Gewebes und der Verbindungsrolle und der vorderen Stange.

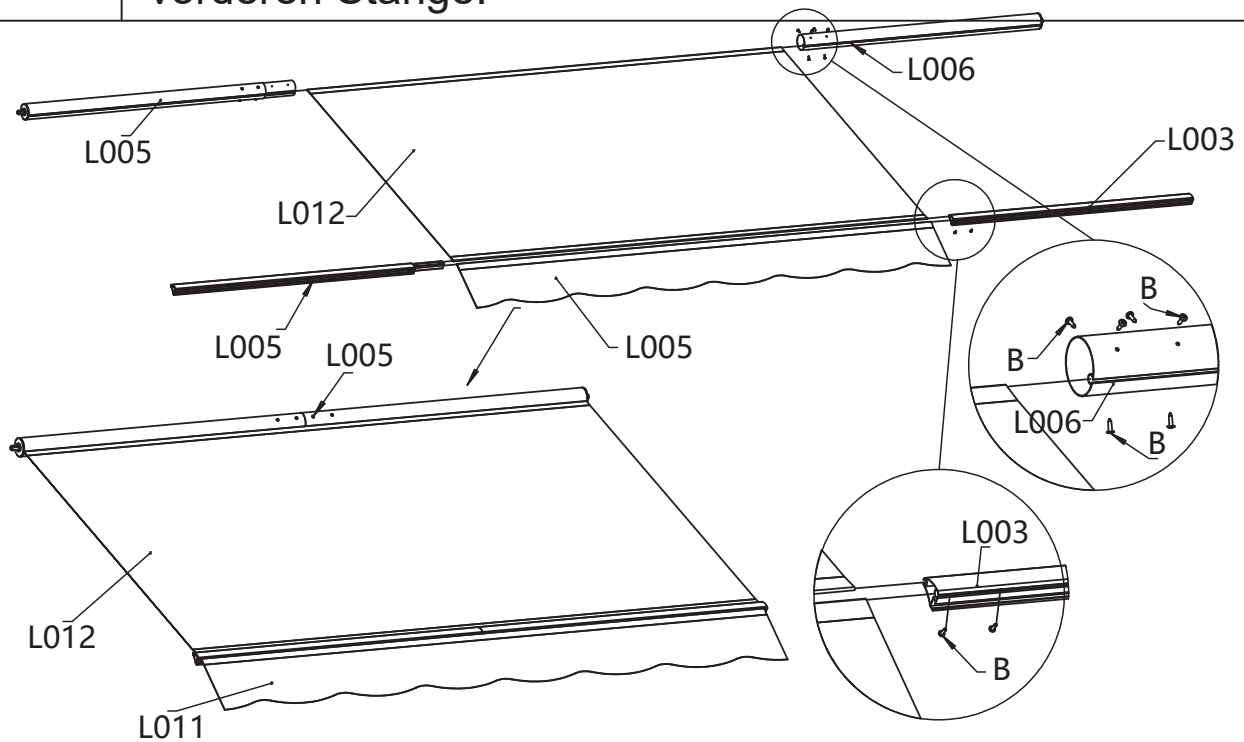

L003 x1



L006 x1



B x8

Schritt 4

1. setzen Sie die Arm-bar Link in die Front bar.
2. setzen Sie das H-Teil in die vordere Stange und sichern Sie es mit der Schraube A.
3. klopfen Sie die Kappen der vorderen Stange.

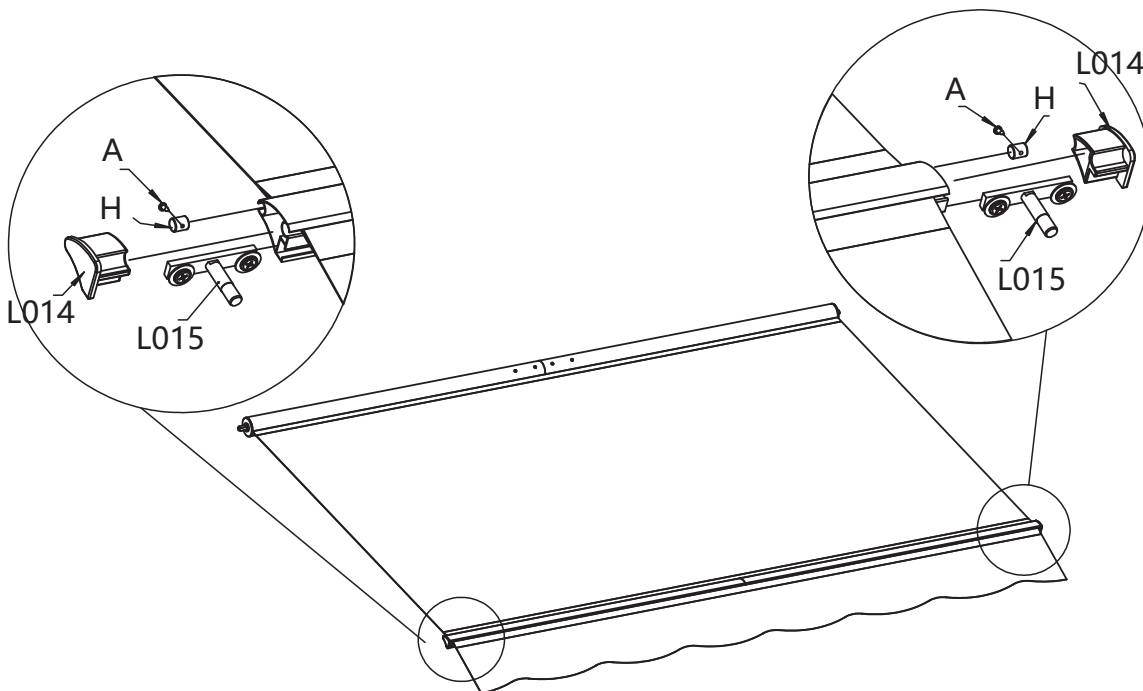

L014 x2

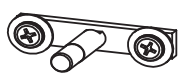

L015 x2

A x2

H x2

Schritt 5 Rollen Sie das Markisentuch so straff wie möglich auf.

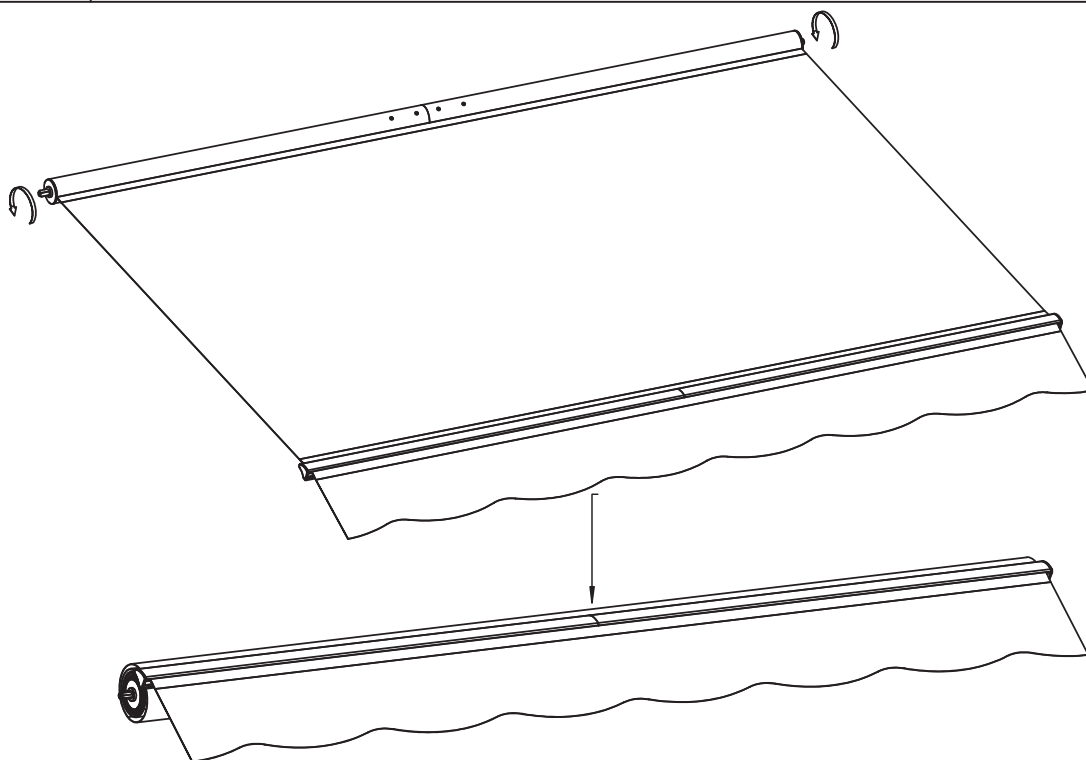

Schritt 6

1. Verbinden Sie die linke Torsionsstange (L001 und L009) und schrauben Sie die rechte Torsionsstange später fest.
2. Setzen Sie die Rolle in das quadratische Loch des Getriebes und die runde Rolle in die Rollenhalterung ein und drücken Sie dann die linke und rechte Seite zusammen.
3. Verbinden und verschrauben Sie die rechte Torsionsstange (L002 und L009).

Einfügen

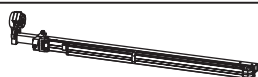
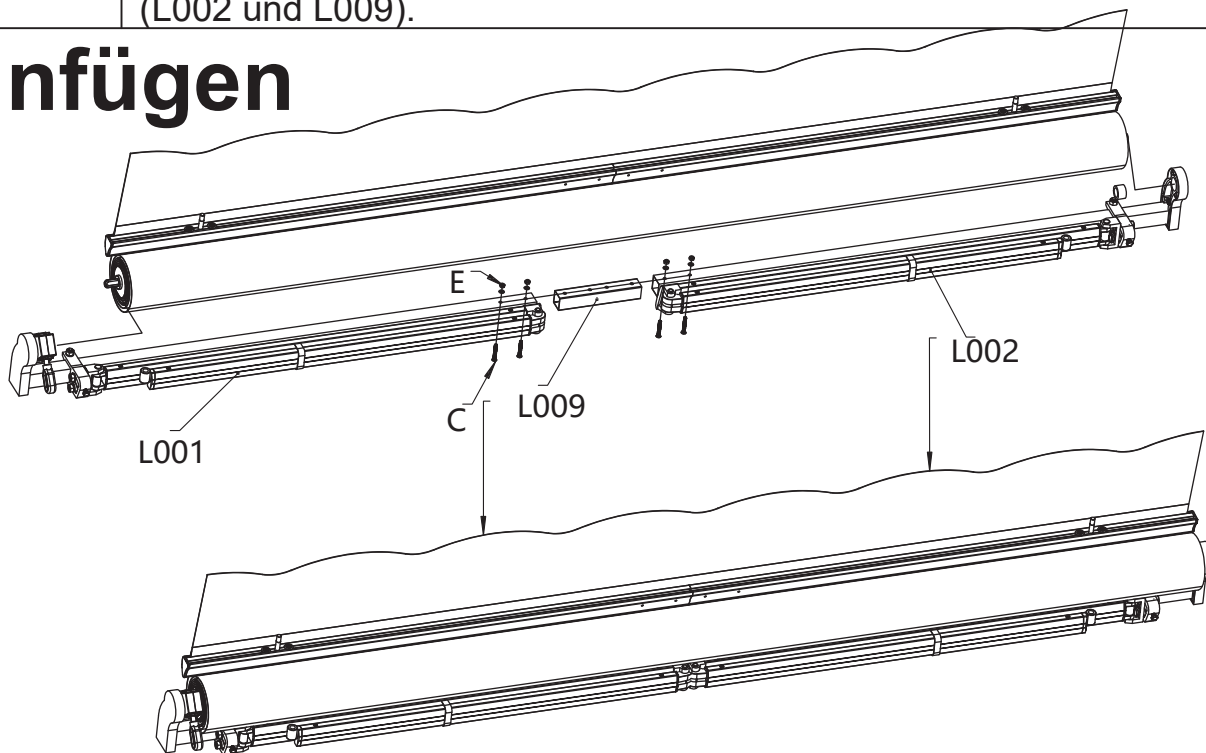

L001 x1

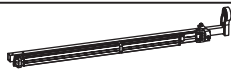

L002 x1

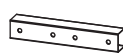

L009 x1



C x4



E x4

Schritt 7

Einstellung der Markisenposition

1. bewegen Sie den Arm-Link, bis die vordere Stange mit dem Handgelenk verbunden ist.
2. richten Sie die Stange und den Arm aus und ziehen Sie die Schraube G an.
3. ziehen Sie dann die verstellbare Schraube G zu 90% fest.

Hinweis: Die vordere Stange wird flach auf die Rolle gelegt.

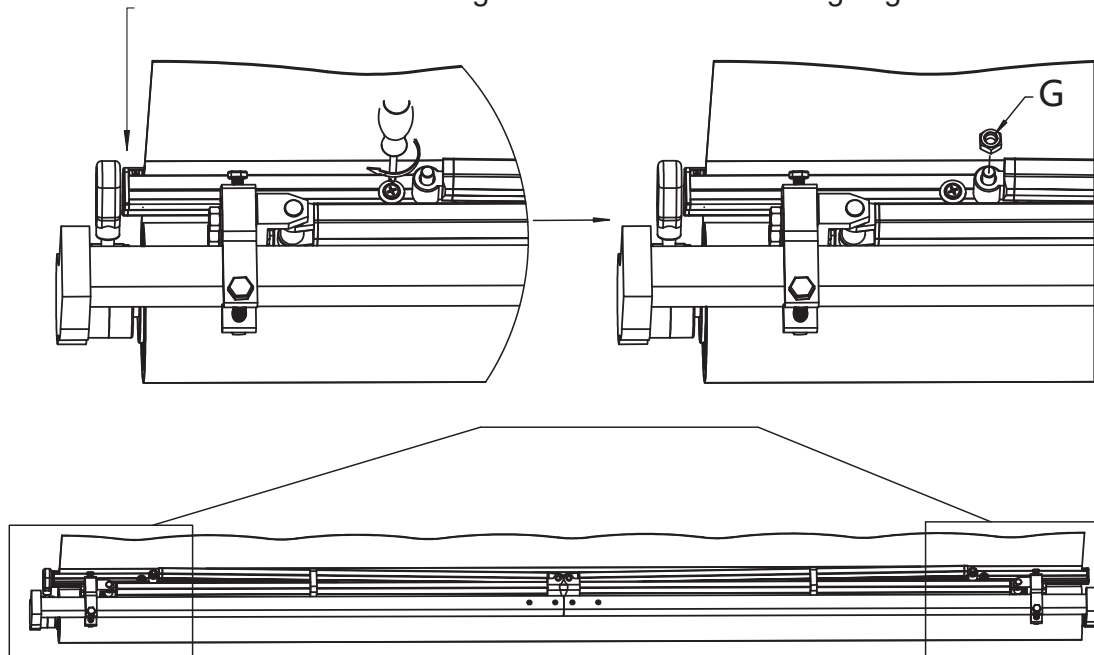

 G x2

Schritt 8

Fertigstellung der Markisenmontage

1. Die Sicherheitsklammern, die die Ausleger und die Torsionsstange festhalten, können nun entfernt werden. Die Markisenmontage ist abgeschlossen.
2. Fahren Sie nun mit der Wandmontage fort.

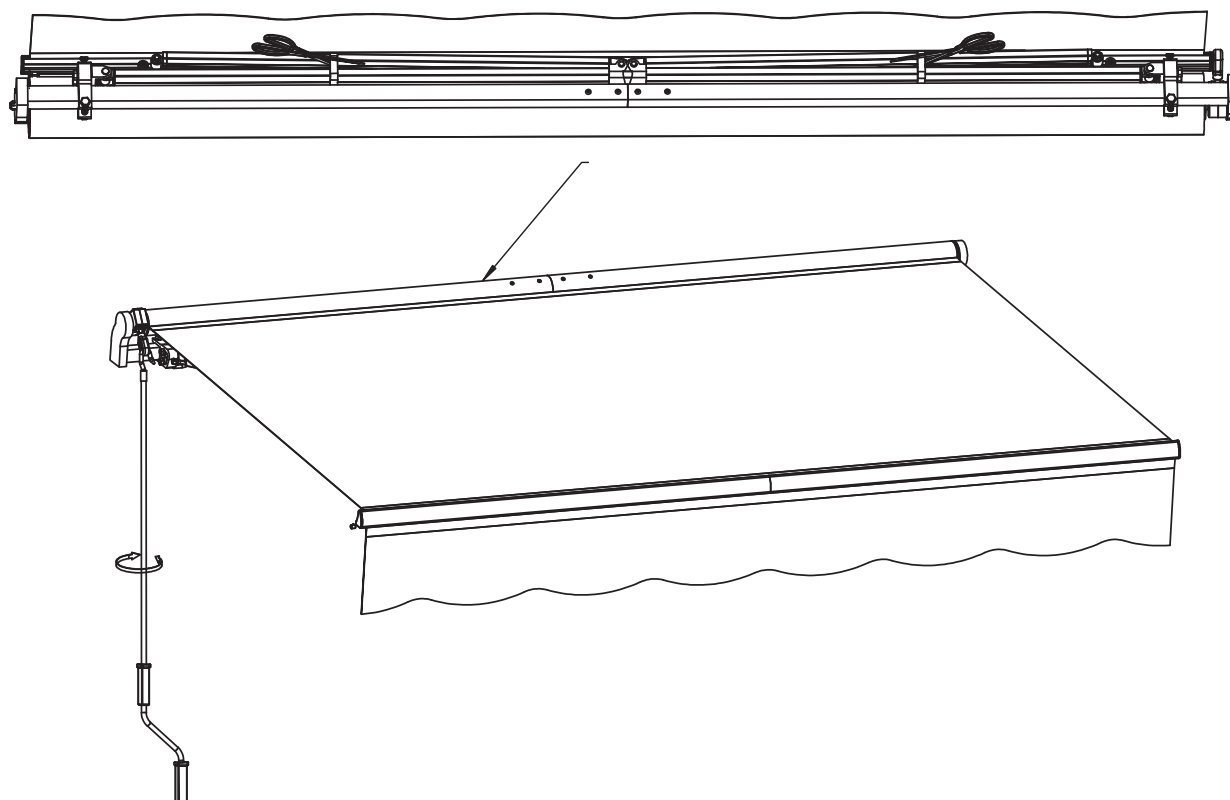

🔧 INSTALLATION

Hinweise zur Anbringung an der Wand

Diese Markise kann an Stahlbeton, Ziegeln und Holz befestigt werden. In diesem Markisenbausatz sind jedoch nur Schrauben enthalten, die für die Befestigung an Ziegel- und Stahlbetonwänden geeignet sind.

Wenn Sie Ihre Markise an Holz befestigen möchten, verwenden Sie bitte Bolzen von ausreichender Länge und mit einem geeigneten Durchmesser, um die Markise an Holzbalken zu befestigen. Das Format der Bolzen hängt vom Format des Holzes ab; diese können Sie in einem Baumarkt erwerben. Wir empfehlen einen professionellen Installateur für den sichersten Einbau.

Versuchen Sie niemals, die Wandhalterungen an Steinen oder anderen Oberflächen zu befestigen, die nicht absolut fest sind!



ACHTUNG: Die ordnungsgemäße Befestigung der Wandhalterungen ist das wichtigste Kriterium für eine schnelle Montage der Wandhalterungen an Bolzen, Pfosten, Dachbalken oder anderen wichtigen Bauteilen.



WARNUNG: Wenn Sie nicht alle Halterungen sicher an der Wand befestigen, kann die Markise einstürzen und zu Verletzungen oder zum Tod führen.

Montagehöhe

Es ist wichtig, den Neigungsbereich der Markise zu berücksichtigen, bevor Sie Ihre Wandhalterungen anschrauben. Wenn Sie die Markise z.B. über einer Terrassentür montieren möchten, lassen Sie bitte mindestens 8 Zoll über dem Türrahmen und stellen Sie sicher, dass die Markise das Öffnen und Schließen der Tür nicht behindert. Der Neigungswinkel kann nur geringfügig verändert werden. Berücksichtigen Sie dies also bei der Entscheidung, wo Sie Ihre Markise anbringen möchten.

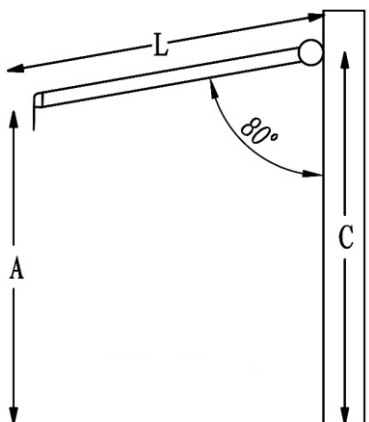

Wir empfehlen, dass die Markisenfläche im geöffneten Zustand einen Winkel von etwa 80 Grad zur Wand bildet.

- **Empfohlene Montagehöhe:** 8 bis 12 Fuß.
- **Der ideale Neigungswinkel (bei vollständig ausgefahrener Markise) wurde bereits im Werk eingestellt**, so dass Sie die Neigung/den Winkel möglicherweise nicht ändern müssen.
- **Die Markise hat einen Neigungswinkel** von 24 Zoll, also 15 Grad.

BERECHNUNGEN:

Sie können die folgende Formel verwenden, um den entsprechenden Winkel zu berechnen.

$$C = A + 0,17 \times L$$

A = Die gewünschte Höhe der vorderen Stange

L = Die Länge des ausgestreckten Arms

C = Die Höhe der Wandhalterung

SCHRITT 1: Ausmessen des Montageortes

1. Messen Sie die Länge Ihrer Markise entlang der Wand, an der Sie sie montieren möchten. Diese Linie wird der höchste Punkt Ihrer Markise sein und mit der Oberkante der Wandhalterung übereinstimmen. Verwenden Sie eine Wasserwaage, um eine Kreidelinie über die Strecke zu ziehen.

2. Wichtig: Prüfen Sie, ob die Linie durchgängig waagrecht ist.

3. Achten Sie darauf, dass die Linie mittig über der Terrassentür, dem Fenster oder, falls zutreffend, einem anderen Element verläuft.

4. Jetzt, wo Sie eine gerade, zentrierte Linie haben, messen Sie den Mittelpunkt und markieren ihn. An dieser Stelle wird die mittlere Wandhalterung montiert.

5. Nehmen Sie eine Wandhalterung und platzieren Sie die Oberseite der Halterung völlig waagrecht unter der Linie, wie in der Abbildung unten gezeigt. Markieren Sie mit Kreide oder einem Bleistift die Position aller Wandhalterungen und deren Bolzenlöcher.

Markisen <10,8 Fuß	Erfordert insgesamt nur 2 Wandhalterungen: eine für jedes Ende der Torsionsstab.
Markisen 10,8 bis 14 Fuß	Erfordert insgesamt 3 Wandhalterungen: eine für jedes Ende und eine in der Mitte.
Markisen 14,5 bis 20 Fuß	Benötigt insgesamt 4 Wandhalterungen: eine für jedes Ende und zwei in der Mitte.

Wandhalterung an der horizontalen Linie ausrichten

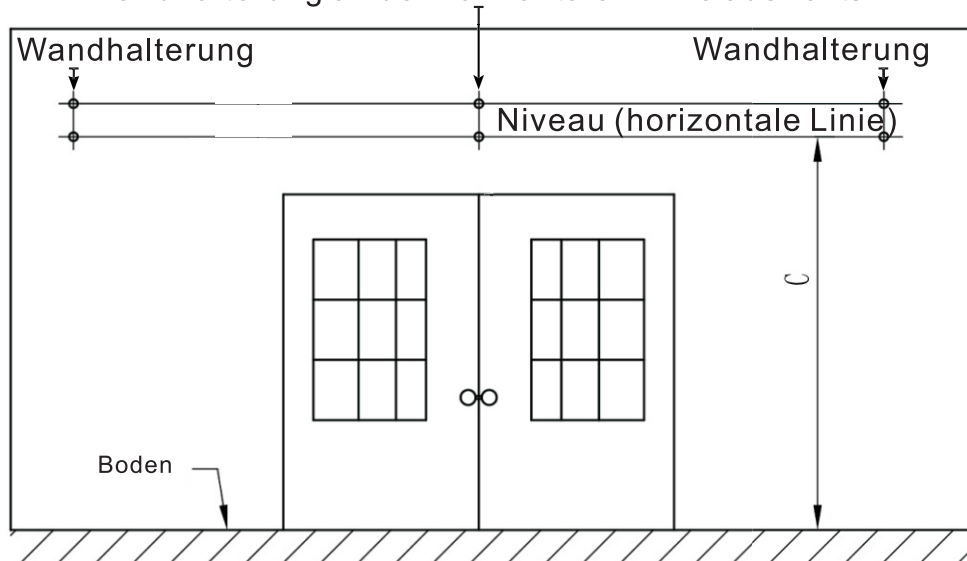

SCHRITT 2: Bohren der Löcher für die Bolzen

1. Nachdem Sie nun eine gerade, ebene Linie über die Wand gezogen und die Positionen der Wandhalterungen und ihrer Bolzenlöcher markiert haben, bohren Sie die Löcher für die Montage der Halterungen.

2. Verwenden Sie einen 14-mm-Mauerbohrer und bohren Sie das erste Bolzenloch etwa 9 cm (4 Zoll) tief, wie in der Abbildung gezeigt. Dieses Loch muss durch soliden Ziegelstein oder Beton gebohrt werden, um der Markise den nötigen Halt zu geben.

3. Bohren Sie die restlichen Löcher genau wie in Schritt 2.

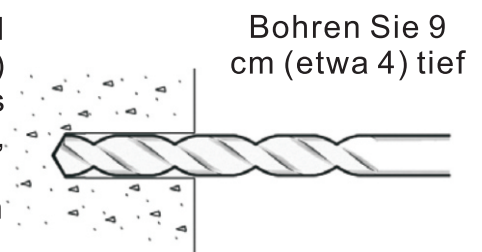

!! WICHTIG: Alle Bolzenlöcher müssen vertikal und horizontal ausgerichtet sein, um sicherzustellen, dass die Markise gerade hängt.

Prüfen Sie die Ausrichtung vor dem Bohren, wenn Sie sich nicht sicher sind. WICHTIG: Der Durchmesser und die Tiefe der Befestigungslöcher müssen mit dem Format der Expansionsbolzen übereinstimmen.



SCHRITT 3: Vorbereitungen für die Montage

1. Nachdem Sie nun alle Löcher gebohrt haben, setzen Sie die Expansionsbolzen ein.

2. Möglicherweise müssen Sie die Bolzen mit einem Holzhammer (oder einem anderen nicht-metallischen Hammer) einschlagen.



Wenn ein Hammer für den Einbau erforderlich ist, empfehlen wir, die Mutter vor dem Einschlagen (lose) auf die Schraube zu setzen, um eine Beschädigung der Bolzengewinde zu vermeiden.

3. Stellen Sie sicher, dass die Bolzen festsitzen, aber noch etwa 1 Zoll oder weniger aus der Wand herausragen - genug, dass die Wandhalterung darauf montiert werden kann.

4. Ziehen Sie die Bolzen mit einem 19-mm-Sechskantschlüssel fest. Verwenden Sie am besten einen Sechskantschlüssel mit einem geschlossenen Ende und nicht mit einem offenen Ende, damit die Mutter nicht beschädigt wird, falls sie abrutscht.

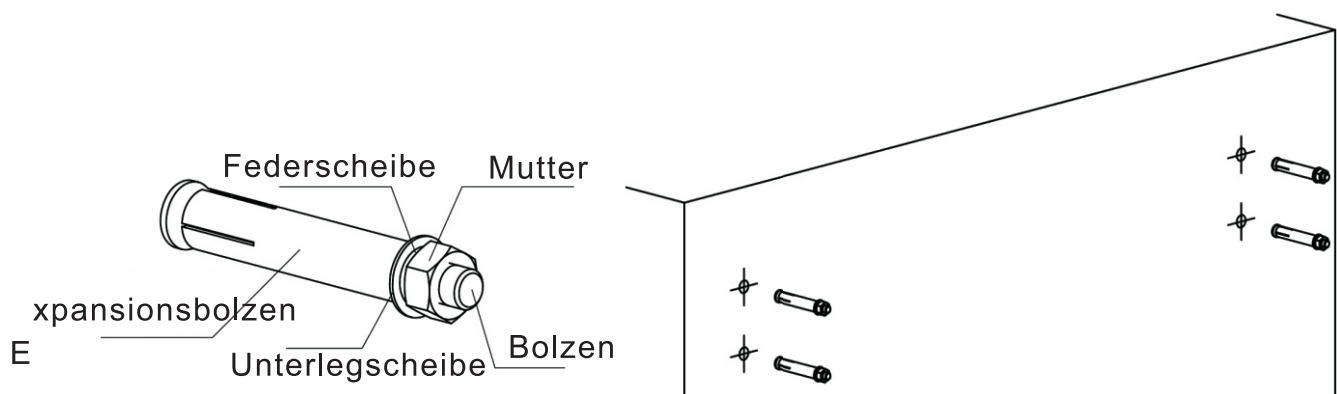

SCHRITT 4: Montage der Wandhalterungen

1. Nachdem die Bolzen nun fest in der Wand sitzen, entfernen Sie die Muttern, die lose auf den Bolzen sitzen.

2. Setzen Sie eine Wandhalterung auf einen Satz Bolzen. Wenn die Löcher für die Bolzen richtig ausgerichtet sind, sollte dies ein Kinderspiel sein.

3. Sobald die Wandhalterung auf den Bolzen aufliegt, legen Sie eine Unterlegscheibe über den Bolzen und sichern ihn dann mit einer Mutter, wie in der Abbildung gezeigt.

4. **Die Halterungen MÜSSEN fest auf der Wand sitzen.** Wenn sie sich bewegen, müssen Sie sie noch fester festziehen.

5. Wiederholen Sie diesen Schritt für jede der Wandhalterungen. Sobald Sie dies getan haben, sind alle Wandhalterungen sicher an ihrem Platz.

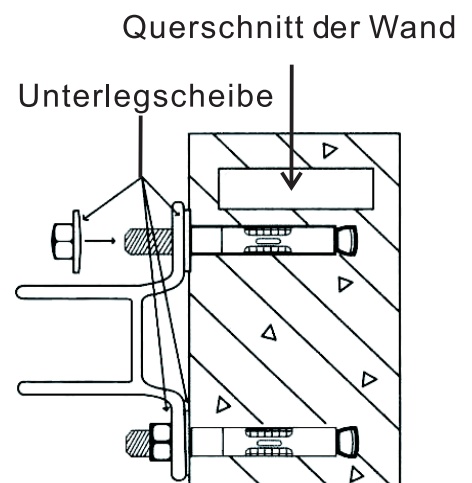

SCHRITT 5: Montage der Markise

1. Jetzt, da die Wandhalterungen sicher und an ihrem Platz sind, ist es an der Zeit, die Markise an den Halterungen zu montieren.
2. Für die Montage der Markise benötigen Sie mindestens zwei Leitern oder stabile Stühle.
3. Setzen Sie die originalen Expansionsbolzen auf die Wandhalterungen und ziehen Sie sie fest.
4. Ziehen Sie schließlich alle Expansionsbolzen an.
5. Verwenden Sie die Handkurbel oder einen Motor (falls vorhanden), um Ihre Markise vollständig zu öffnen. Die vordere Stange sollte waagrecht sein.
6. **Herzlichen Glückwunsch! Ihre Markise ist montiert. Wenn Sie mit der Höhe der vorderen Stange (Markisenneigung) zufrieden sind, können Sie sich zurücklehnen und genießen! Wenn nicht, lesen Sie bitte weiter.**

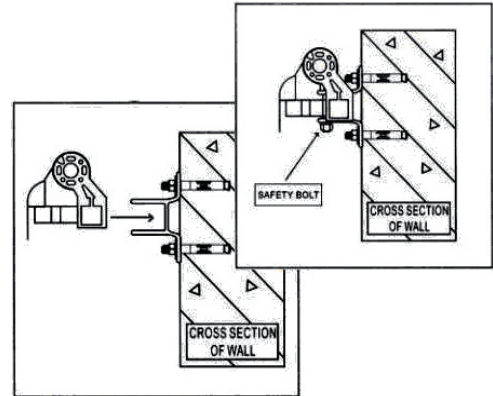

😊 OPTIONALE MONTAGE

ANPASSUNG DER MARKISENNEIGUNG/DES NEIGUNGSWINKELS

Jede Markise wird mit einer voreingestellten Neigung (Winkel) geliefert, die als ideal angesehen wird. Wenn Sie jedoch eine Anpassung vornehmen möchten, können Sie dies in wenigen einfachen Schritten tun.

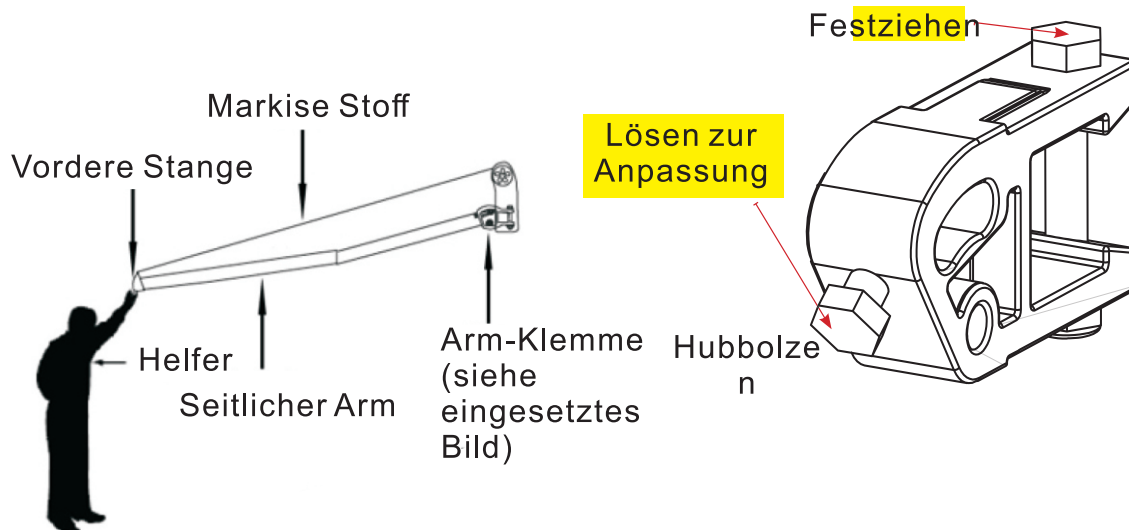

!!! WICHTIG: Wenn Sie die vordere Stange anheben, verringert sich der Neigungswinkel der Markise, wodurch sich das Risiko erhöht, dass Regenwasser auf das Tuch läuft. Um zu verhindern, dass die Markise durch das Gewicht des Regenwassers zusammenbricht, müssen Sie die Markise einfahren, wenn Sie unbeaufsichtigt sind. Wenn Sie dies nicht tun, kann die Markise beschädigt werden oder Sie können sich verletzen.

Hinweis: Vergewissern Sie sich, dass die vordere Stange völlig gleichmäßig ausgerichtet ist. Jede Fehlausrichtung führt dazu, dass die Markise nicht richtig eingefahren wird.

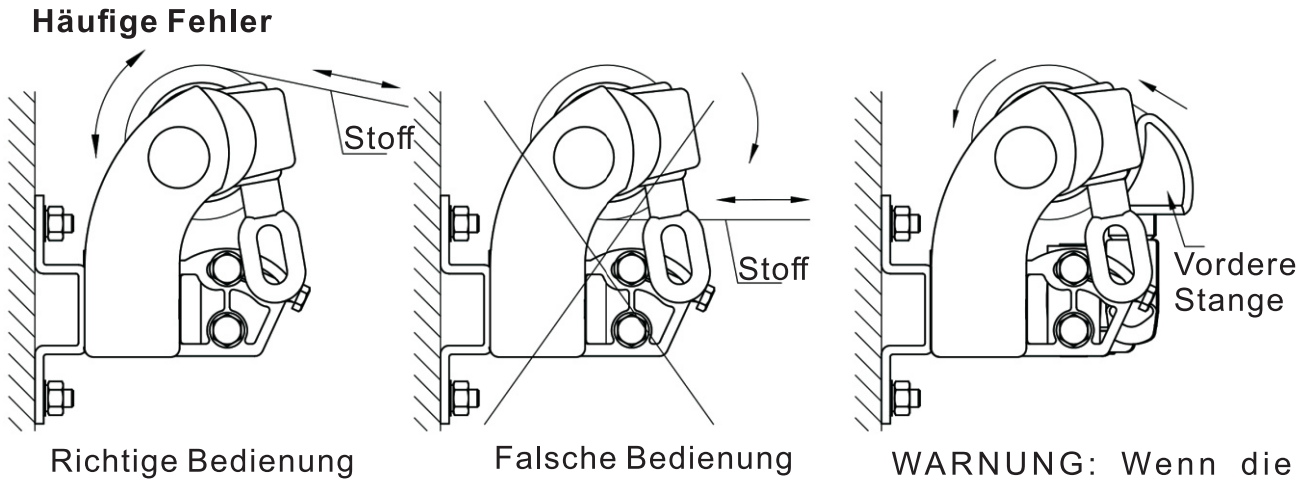

WARNUNG: Wenn die vordere Stange die Walze berührt, wie in der Abbildung gezeigt, versuchen Sie nicht, sie weiter anzunähern, da das Produkt sonst beschädigt werden kann.

INSTRUCTION

1008 Auvent

Instructions de montage et d'entretien

FR

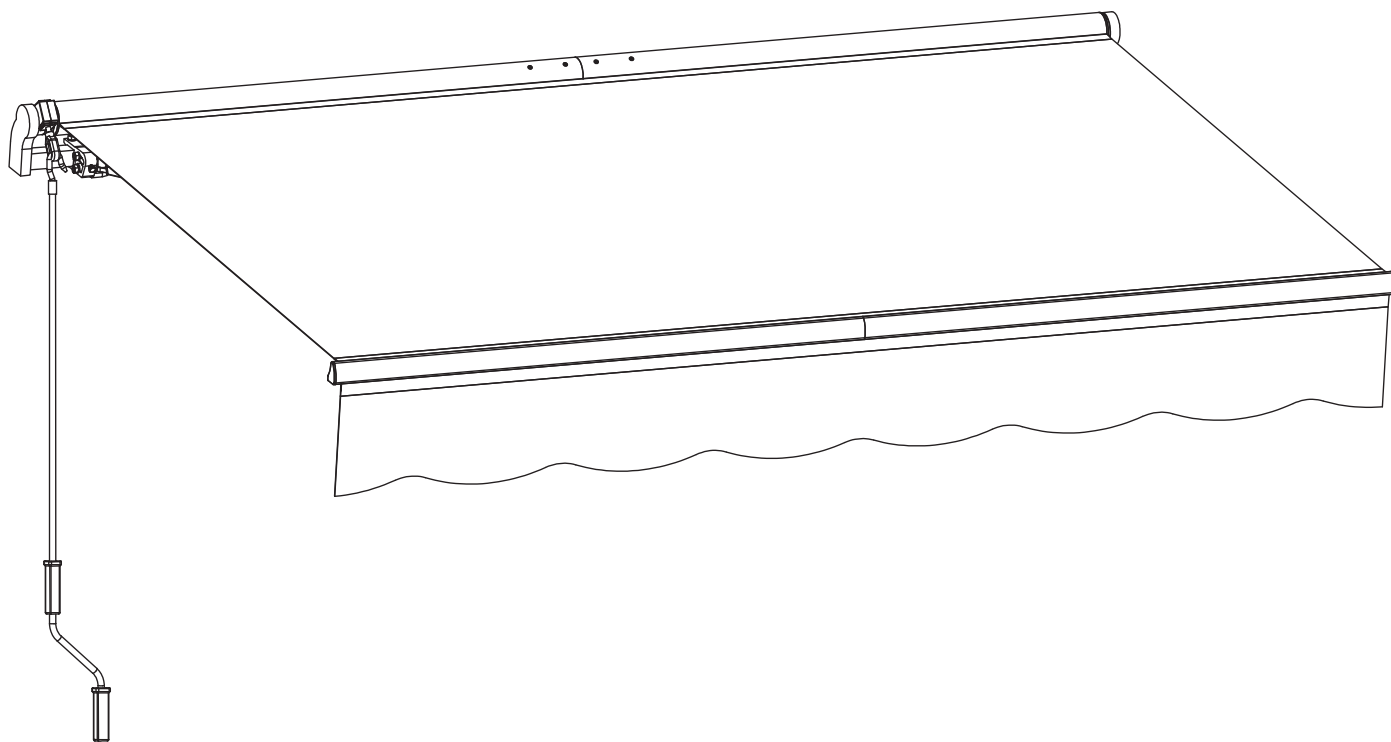

SKU:P25812-D1

IMPORTANT

À LIRE AVANT DE COMMENCER L'ASSEMBLAGE

Suivez les instructions contenues dans ce guide d'utilisation afin d'assurer le montage correct et l'entretien de ce produit.

Catalogue

Avis	3
Spécifications	4
Vue éclatée	4
Liste des pièces.....	5
Jeu de vis	6
Extra	6
Étapes de l'installation.....	7

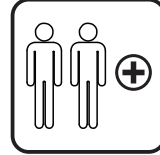
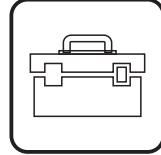
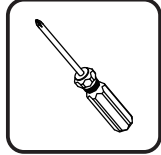
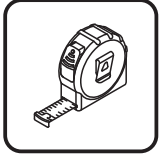
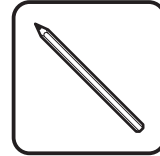
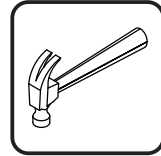
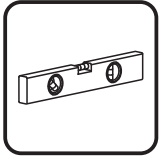

Veillez vérifier toutes les pièces et tous les composants présents et vérifier qu'aucune pièce n'est endommagée avant l'assemblage. Si vous constatez que des pièces sont endommagées ou manquantes, veuillez contacter le service clientèle à l'adresse hgeurope@outlook.com.
Contactez-nous:

hgeurope@outlook.com

IMPORTANT

À CONSERVER POUR RÉFÉRENCE ULTÉRIEURE : À LIRE ATTENTIVEMENT.

CONSEILS

NE PAS UTILISER PAR MAUVAIS TEMPS POUR ÉVITER LES DOMMAGES.

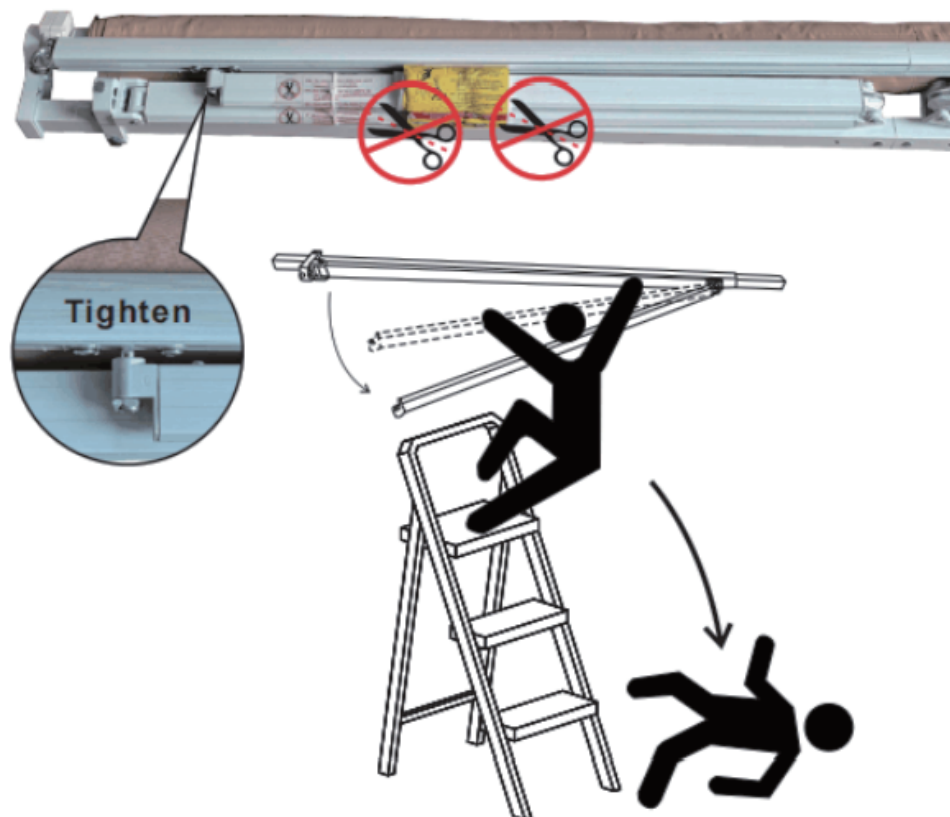

DANGER

CUTTING THE CABLE TIES BEFORE ASSEMBLY MAY CAUSE INJURY.

SPÉCIFICATIONS

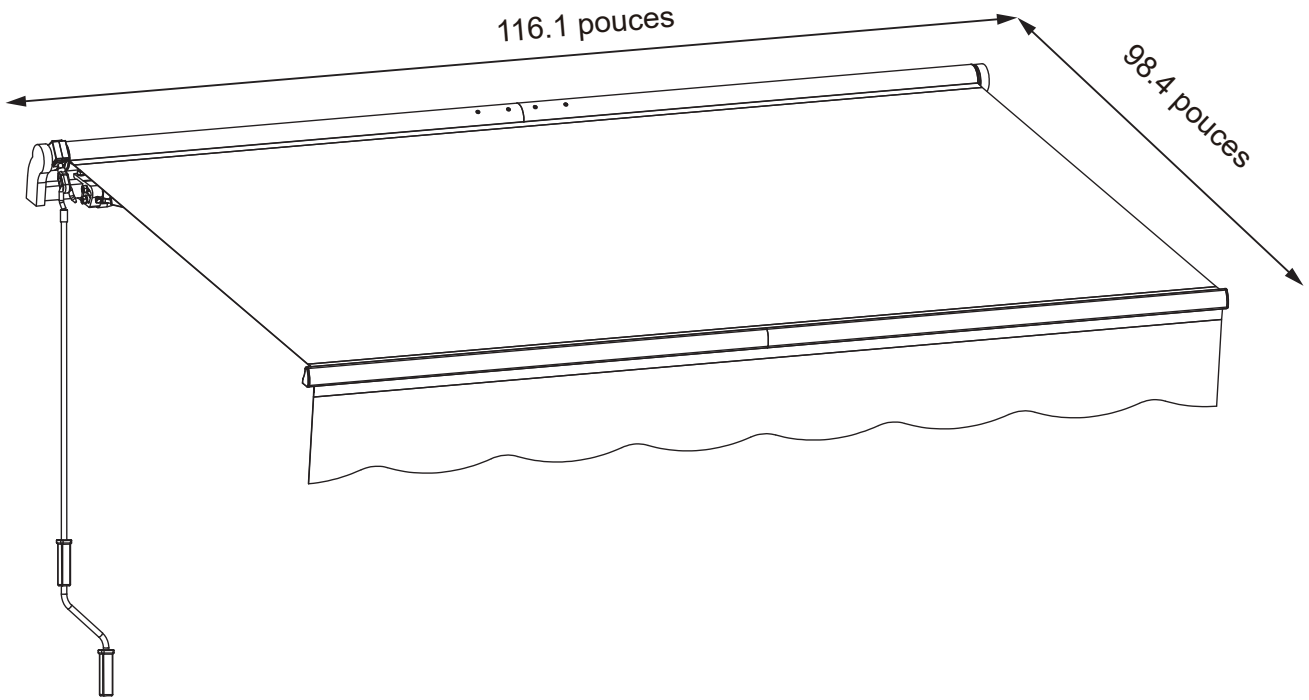





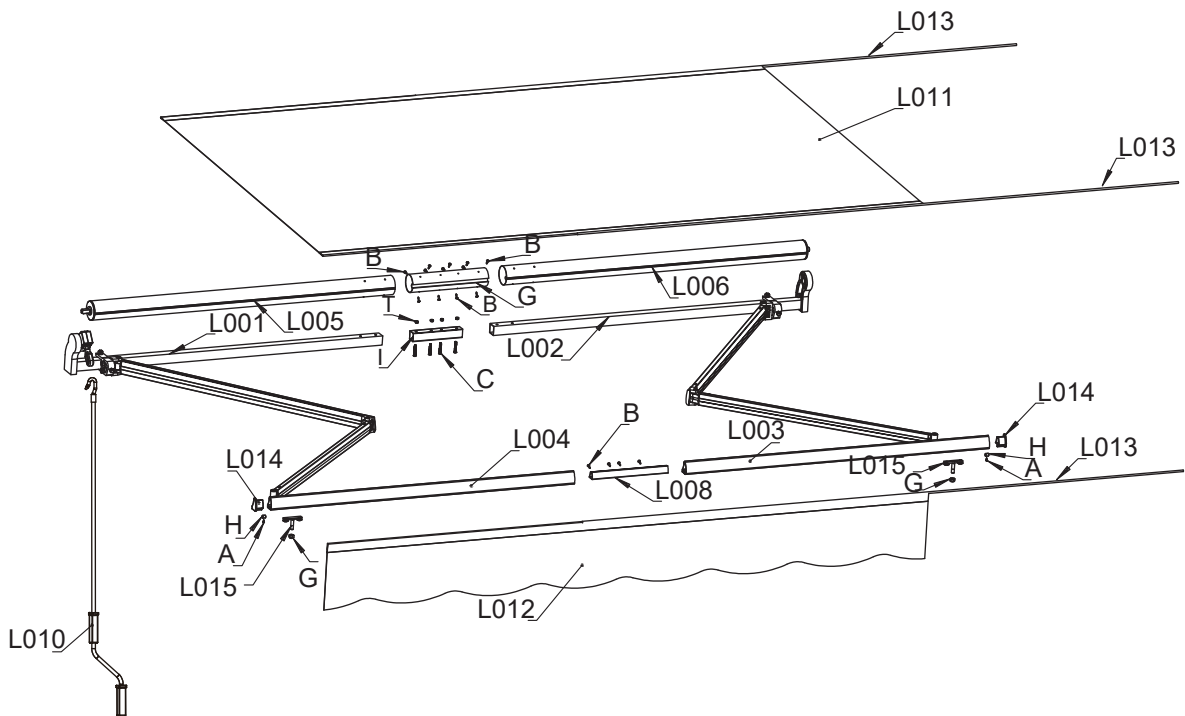



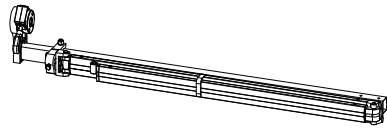
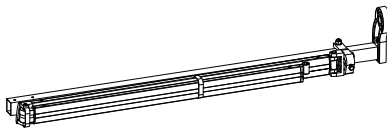

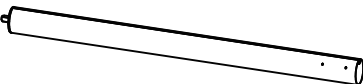
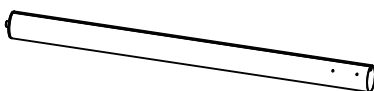
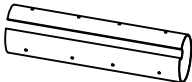
VUE ÉCLATÉE

VUE ÉCLATÉE

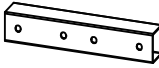

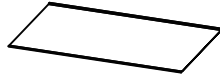



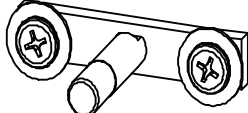
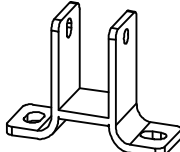

LISTE DES PARTIES

Partie	Icône	Quantité
L001		1
L002		1
L003		1
L004		1
L005		1
L006		1
L007		1
L008		1

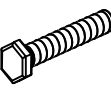



Partie	Icône	Quantité
L009		1
L010		1
L011		1
L012		1
L013		3
L014		2
L015		2
L016		2

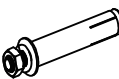
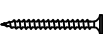

ENSEMBLE DE VIS

Partie	Icône	Quantité
A	 ST3*10	2
B	 ST4*15	16
C	 M6*40	4
D	 M8*55	2
E	 M6	4

Partie	Icône	Quantité
F	 M8	2
G	 M10	2
H	 M6	2
I	 M8	4
J	 M6	4

EXTRA

Partie	Icône	Quantité
A	 ST3*10	1
B	 ST4*15	2
C	 M6*40	1
D	 M8*55	1
E	 M6	1

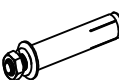
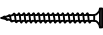
Partie	Icône	Quantité
F	 M8	1
G	 M10	1
H	 M6	1
I	 M8	1
J	 M6	1

Étape 3 Assemblage du tissu et connexion du rouleau et de la barre frontale.

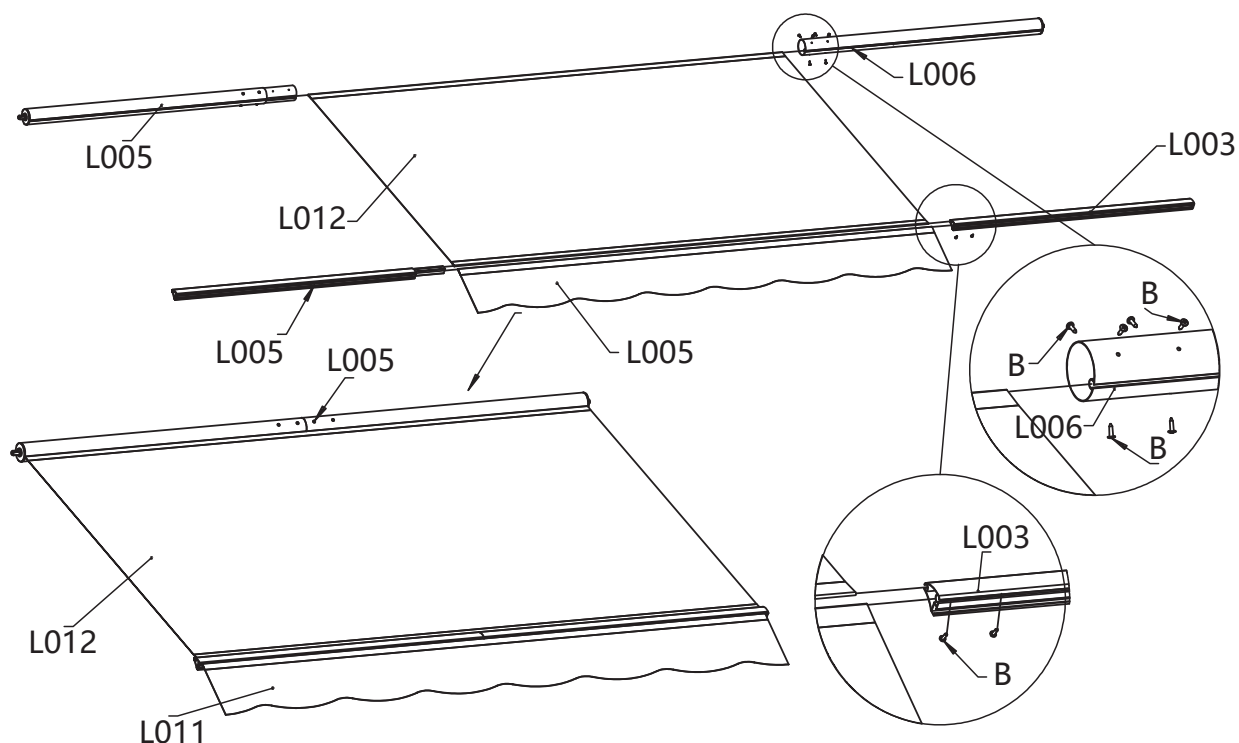

L003 x1



L006 x1



B x8

Étape 4

1. placer le lien de la barre de bras dans la barre avant.
2. placer la partie H dans la barre avant et la verrouiller avec la vis A.
3. Tapoter les capuchons de la barre avant.

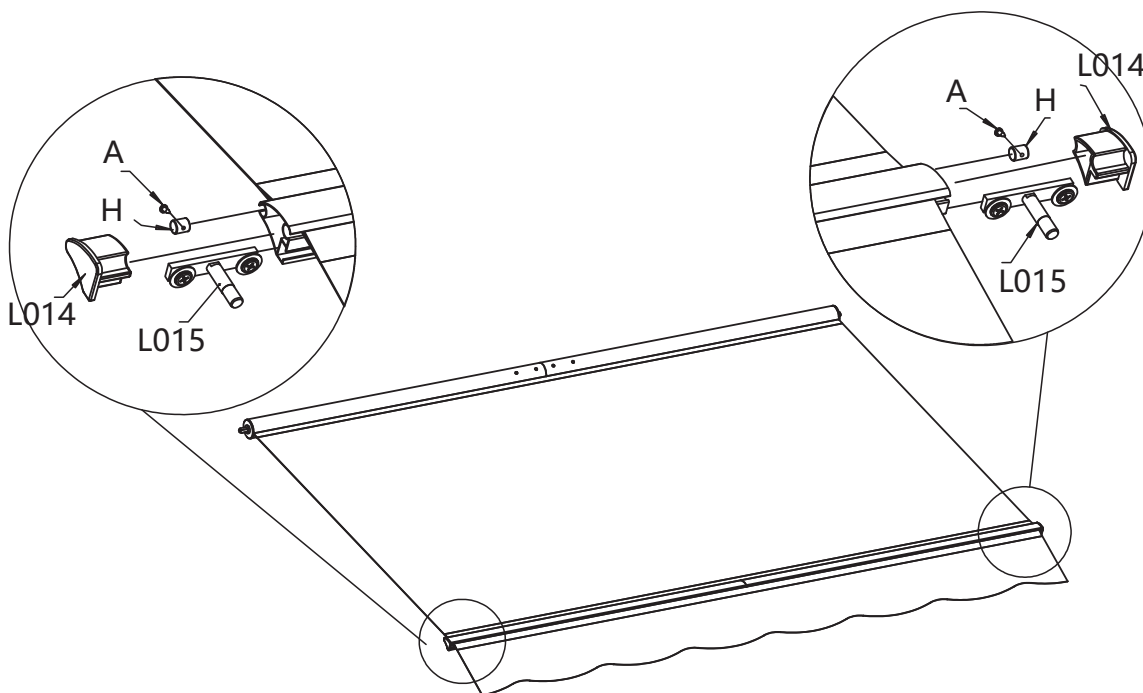

L014 x2



L015 x2

A x2

H x2

Étape 5 Enroulez la toile de l'auvent aussi serré que possible.

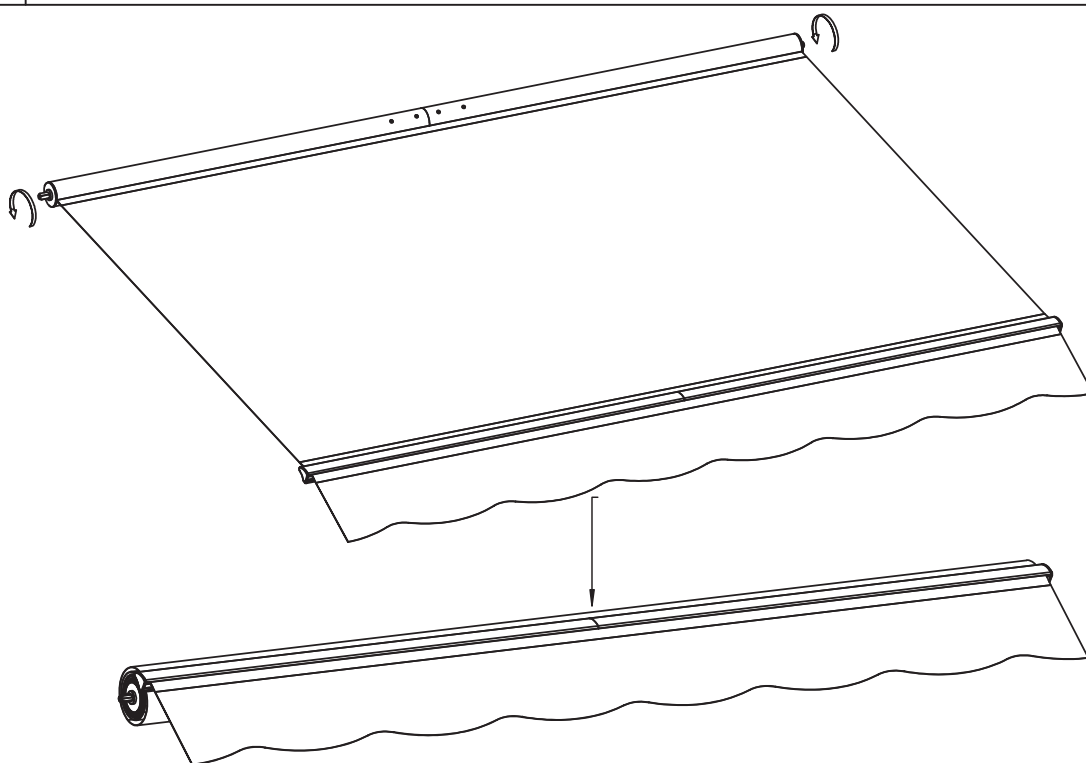

Étape 6

1. Connectez la barre de torsion gauche (L001 et L009), puis vissez la barre de torsion droite.
2. Insérez le rouleau dans le trou carré de la boîte d'engrenages et dans le rond du support du rouleau, puis poussez les côtés gauche et droit ensemble.
3. Connectez et vissez la barre de torsion droite (L002 et L009).

Insérer

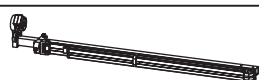
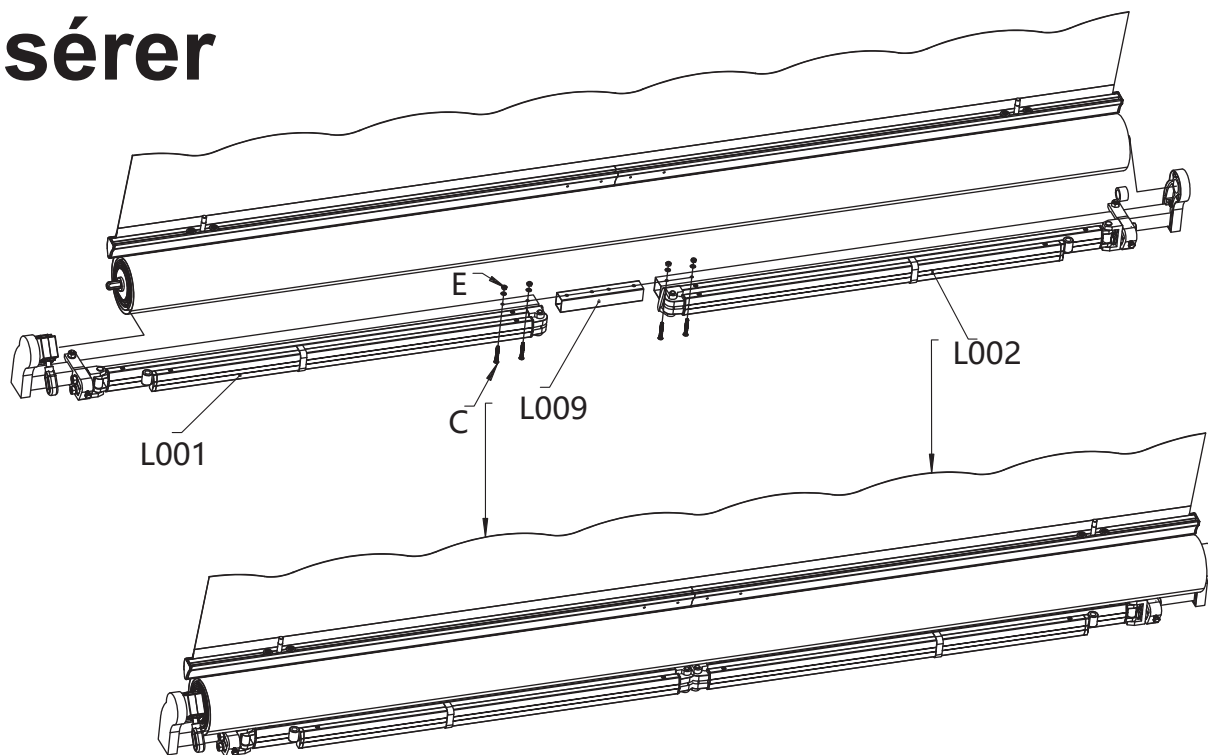

L001 x1

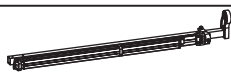

L002 x1

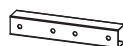

L009 x1



C x4



E x4

Étape 7

Réglage de la position de l'auvent

1. Déplacez le bras articulé jusqu'à ce que le support de poignet de la barre avant soit connecté à travers celui-ci.
2. Alignez la barre avant et le bras, puis serrez la vis G.
3. Serrez ensuite le boulon réglable G à 90 % de son couple maximal.

Note : La barre frontale est placée à plat avec le rouleau.

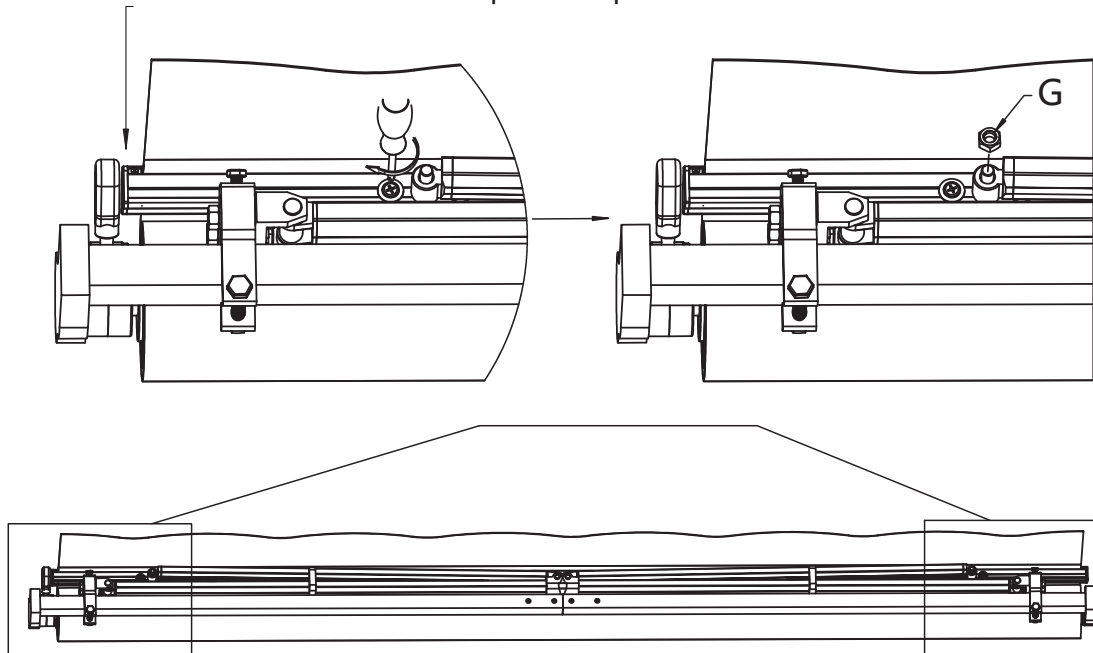

 G x2

Étape 8

Finition de l'assemblage de l'auvent

1. Vous pouvez couper les languettes de sécurité qui maintiennent les bras C et la barre de torsion en place. L'assemblage de l'auvent est terminé.
2. Passez maintenant à la section consacrée au montage mural.

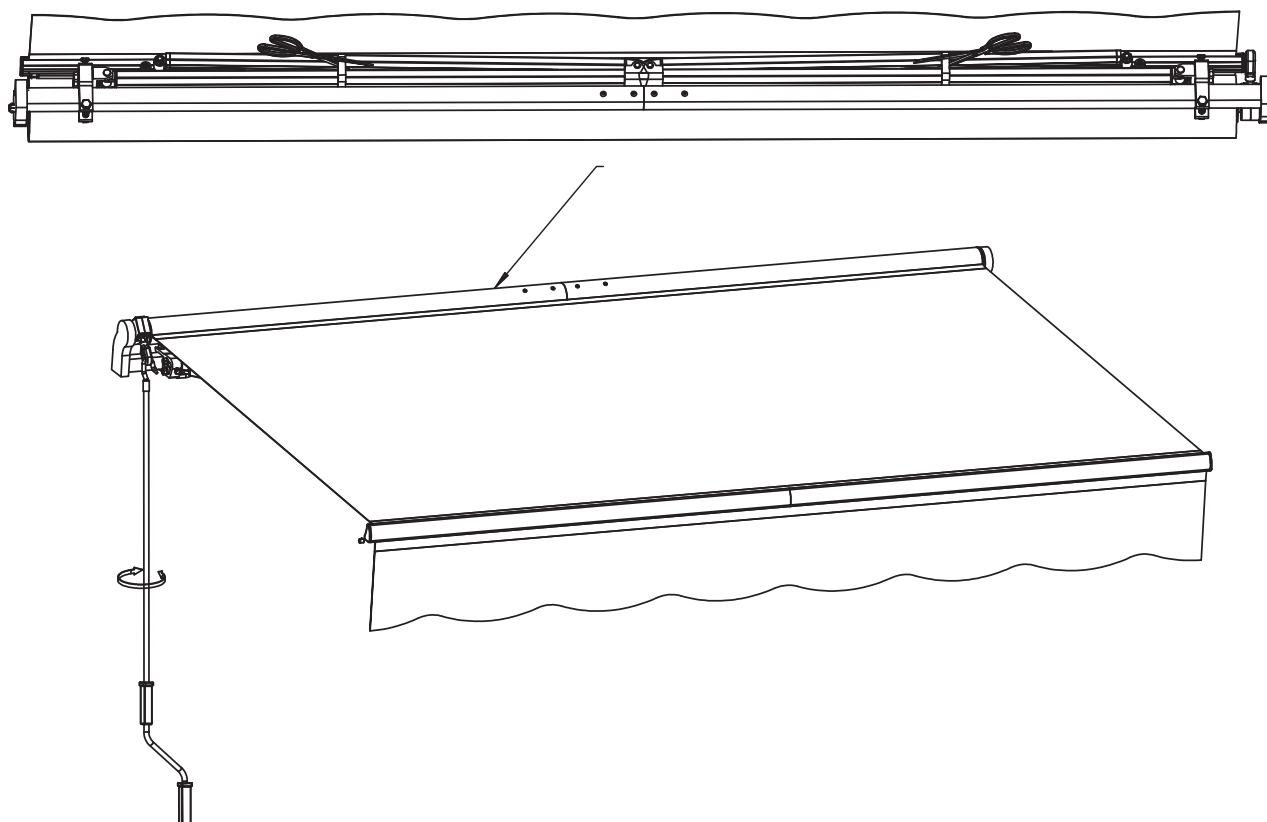

🔧 INSTALLATION

Remarques concernant le montage mural

La fixation de cet auvent peut se faire sur du béton armé, de la brique et du bois. Pour autant, ce kit d'auvent ne comporte que des vis adaptées à la fixation sur des murs en brique et en béton armé.

Pour la fixation de l'auvent sur du bois, veuillez à utiliser des boulons de carrosserie d'une longueur et d'un diamètre suffisants pour fixer l'auvent sur des poutres en bois. La dimension des boulons diffère selon la taille du bois. Ces boulons peuvent être achetés chez un détaillant en quincaillerie. Pour une installation plus sûre, nous vous recommandons de faire appel à un installateur professionnel.

Il ne faut jamais essayer de fixer les supports muraux à des pierres de taille ou à toute autre surface qui n'est pas absolument ferme !



MISE EN GARDE : la fixation appropriée des supports représente l'aspect le plus important de l'installation. Il est essentiel que vous fixiez plus rapidement tous les supports de montage sur des goujons, des poteaux, des collecteurs ou d'autres éléments structurels importants.



AVERTISSEMENT : si tous les supports ne sont pas solidement fixés au mur, l'auvent risque de s'effondrer et de provoquer des blessures corporelles, voire la mort.

Hauteur de montage

Vous devez tenir compte de la zone de descente de l'auvent avant de visser vos supports muraux. Par exemple, si vous souhaitez installer votre auvent au-dessus d'une porte-fenêtre, laissez un espace d'au moins 8 pouces au-dessus du cadre de la porte et assurez-vous que l'auvent n'interfère pas avec l'ouverture et la fermeture de la porte. Étant donné que l'angle de descente ne peut être modifié que de façon minimale, tenez-en compte lorsque vous décidez de l'emplacement de votre auvent.

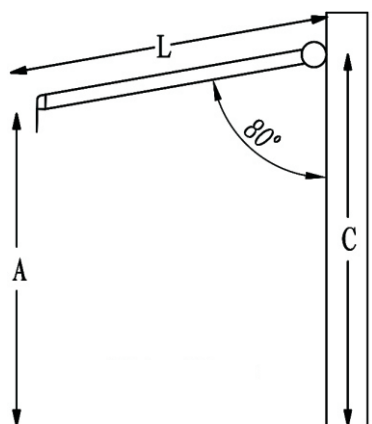

En position ouverte, nous vous conseillons d'orienter la surface de l'auvent vers le mur à un angle d'environ 80 degrés.

● **Hauteur d'installation recommandée :** 8 à 12 pieds.

● **Nous avons déjà réglé en usine l'angle de descente idéal (lorsque le store est entièrement déployé),** il est donc possible que vous n'ayez pas à modifier l'inclinaison ou l'angle.

● **L'auvent peut atteindre une descente** de 24 pouces à l'inclinaison, soit 15 degrés.

CALCULS :

Pour calculer l'angle approprié, vous pouvez utiliser la formule suivante :

$$C = A + 0,17 * L$$

A = La hauteur souhaitée de la barre frontale

L = La longueur du bras tendu

C = La hauteur des supports muraux

ÉTAPE 1 : Prise de mesure de l'emplacement de montage

1. Prenez la mesure de la longueur de votre auvent le long du mur où vous avez l'intention de l'installer. Le point le plus haut de votre auvent sera cette ligne, qui s'alignera sur le haut du support mural. À l'aide d'un niveau, tracez une ligne à la craie sur toute la distance.

2. Important : veillez à ce que la ligne soit bien horizontale sur toute la longueur.

3. Faites en sorte que la ligne soit centrée par rapport à la porte-fenêtre, à la fenêtre ou à tout autre élément, le cas échéant.

4. Une fois la ligne droite et centrée, mesurez le point central et marquez-le. Le support mural du milieu sera installé à cet endroit.

5. Prenez un support mural et placez sa partie supérieure, parfaitement à niveau, sous la ligne, comme le montre le schéma ci-dessous. Utilisez une craie ou un crayon pour marquer la position de tous les supports muraux et leurs trous de fixation.

Auvents < 10,8 pieds	Ne nécessite que 2 supports muraux au total : un pour chaque extrémité des barres de torsion.
Auvents de 10,8 à 14 pieds	Il faut 3 supports muraux au total : un pour chaque extrémité et un au milieu.
Auvents de 14,5 à 20 pieds	Il faut 4 supports muraux au total : un pour chaque extrémité et deux au milieu.

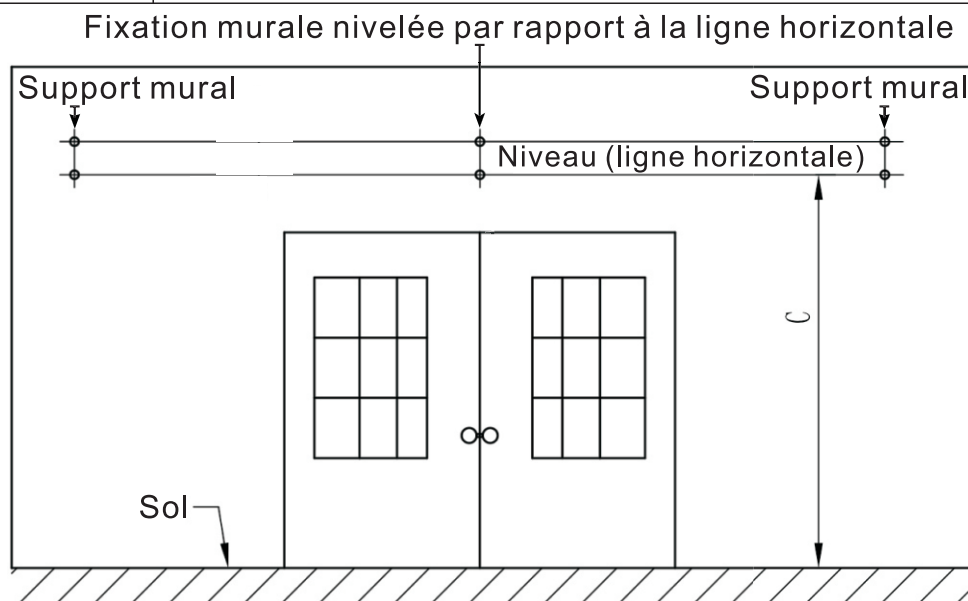

ÉTAPE 2 : Perçage des trous de fixation

1. Après avoir tracé une ligne droite et horizontale sur le mur et marqué l'emplacement des supports muraux et de leurs trous de fixation, vous allez maintenant percer les trous pour monter les supports.

2. À l'aide d'une mèche à maçonnerie de 14 mm, percez le premier trou de fixation à une profondeur d'environ 9 centimètres (4 pouces), comme indiqué sur le schéma. Il faut percer à travers une brique solide ou du béton pour offrir le support nécessaire à l'auvent.

3. Procédez de la même manière qu'à l'étape 2 pour percer les autres trous.

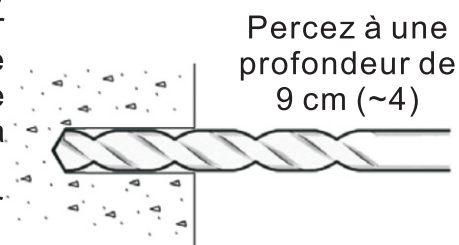

!! IMPORTANT : Il faut aligner tous les trous des boulons verticalement et horizontalement pour que l'avent soit bien suspendu.
Si vous n'êtes pas sûr, vérifiez l'alignement avant de percer.

!! IMPORTANT : les trous de montage doivent avoir le même diamètre et la même profondeur que les boulons d'expansion.

ÉTAPE 3 : Préparation du montage

1. Après avoir percé tous les trous, insérez les boulons d'expansion.
2. Vous devrez peut-être enfoncer les boulons à l'aide d'un maillet en bois (ou d'un autre outil non métallique).



Si vous devez utiliser un maillet pour l'installation, nous vous recommandons de placer l'écrou sur la vis (sans le serrer) avant d'enfoncer le maillet afin d'éviter d'endommager le filetage du boulon.

3. Faites en sorte que les boulons soient fermement en place, tout en les laissant dépasser du mur d'environ 1 pouce ou moins - suffisamment pour que le support mural puisse être installé dessus.
4. Serrez fermement les boulons à l'aide d'une clé hexagonale de 19 mm. Mieux vaut utiliser une clé hexagonale à bout fermé plutôt qu'à bout ouvert pour éviter d'endommager l'écrou s'il venait à glisser.

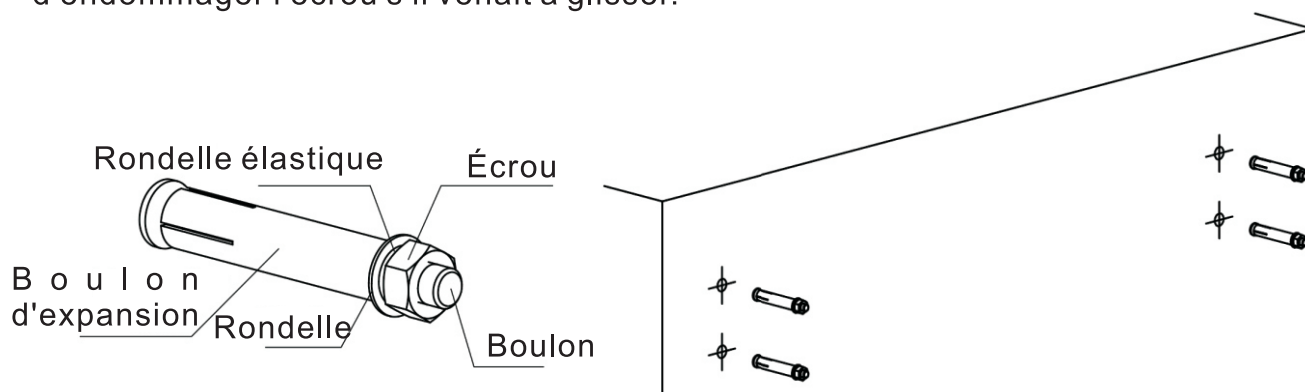

ÉTAPE 4 : Montage des supports muraux

1. Une fois les boulons solidement ancrés dans le mur, retirez les écrous qui les recouvrent sans les serrer.
2. Placez un support mural sur un jeu de boulons. Le montage devrait être facile si les trous des boulons sont correctement alignés.
3. Après avoir posé le support mural sur les boulons, mettez une rondelle sur le boulon, puis fixez-la à l'aide d'un écrou, comme le montre le schéma.
4. **La fixation DOIT être fermement ancrée au mur.** Si un mouvement se produit, vous devez serrer davantage.
5. Il faut répéter cette étape pour chacun des supports muraux. Une fois cette opération effectuée, tous les supports muraux sont bien en place.

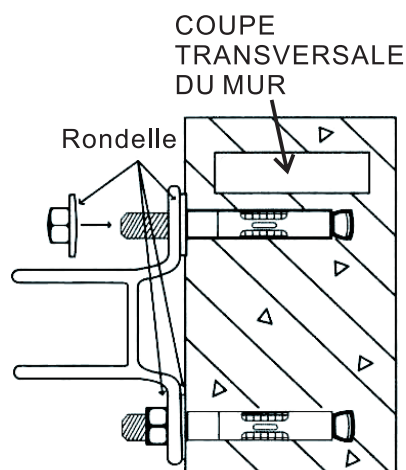

ÉTAPE 5 : Montage de l'auvent

1. Une fois les supports muraux bien en place, il est temps d'installer l'auvent sur les supports.
2. Deux échelles au moins ou des chaises robustes sont nécessaires pour installer l'auvent.
3. Insérez les boulons d'expansion d'origine sur les supports muraux et serrez-les.
4. Pour terminer, fixez tous les boulons d'expansion.
5. Ouvrez complètement votre auvent à l'aide de la manivelle ou d'un moteur (le cas échéant). La barre frontale doit être nivelée.
6. **Vous voilà rassuré ! Votre auvent est installé. Si la hauteur de la barre frontale (inclinaison de l'auvent) vous convient, vous pouvez vous asseoir et profiter de l'auvent ! Si vous n'êtes pas satisfait, veuillez lire ce qui suit.**

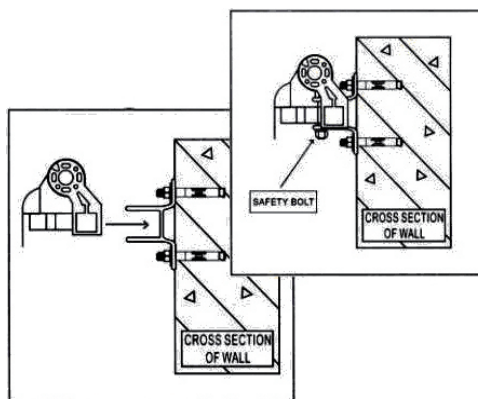

😊 INSTALLATION OPTIONNELLE

RÉGLAGE DE L'INCLINAISON DE L'AUVENT

Tous les auvents sont livrés avec une inclinaison (un angle) prédéfinie, considérée comme idéale. Si toutefois vous avez besoin d'effectuer un réglage, vous pouvez le faire en quelques étapes simples.

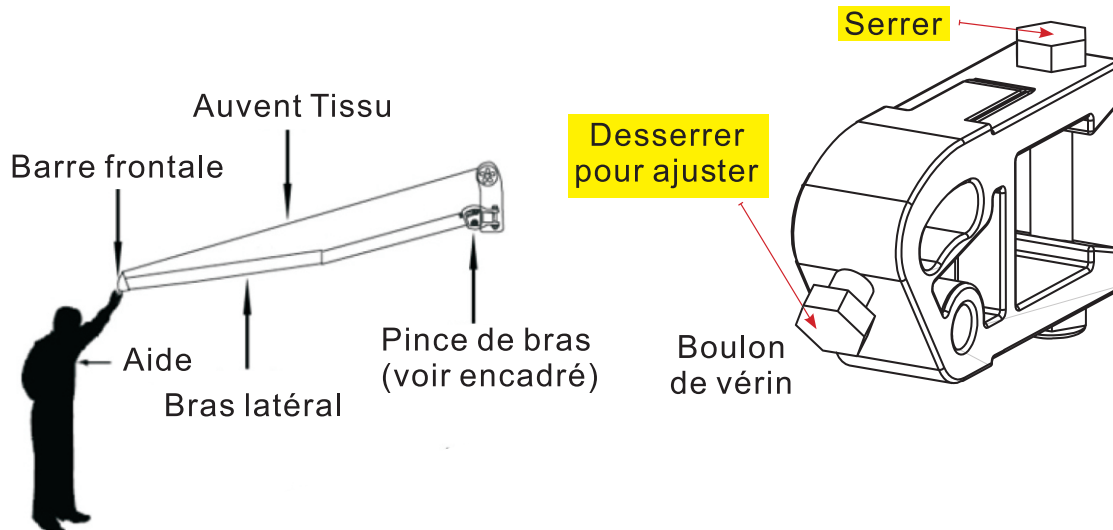

!!! IMPORTANT : Le fait de remonter la barre frontale va réduire l'inclinaison (l'angle) de l'auvent, augmentant ainsi le risque de polissage de la toile par l'eau de pluie. Vous devez attacher l'auvent lorsqu'il est surveillé afin d'éviter qu'il ne s'effondre sous l'effet du poids de l'eau de pluie. Si vous ne respectez pas cette consigne, vous risquez de casser l'auvent ou de vous blesser.

Remarque : veillez à ce que la barre frontale soit réglée de manière à être parfaitement plane. Tout défaut d'alignement entraînera une mauvaise rétraction.

Erreurs courantes

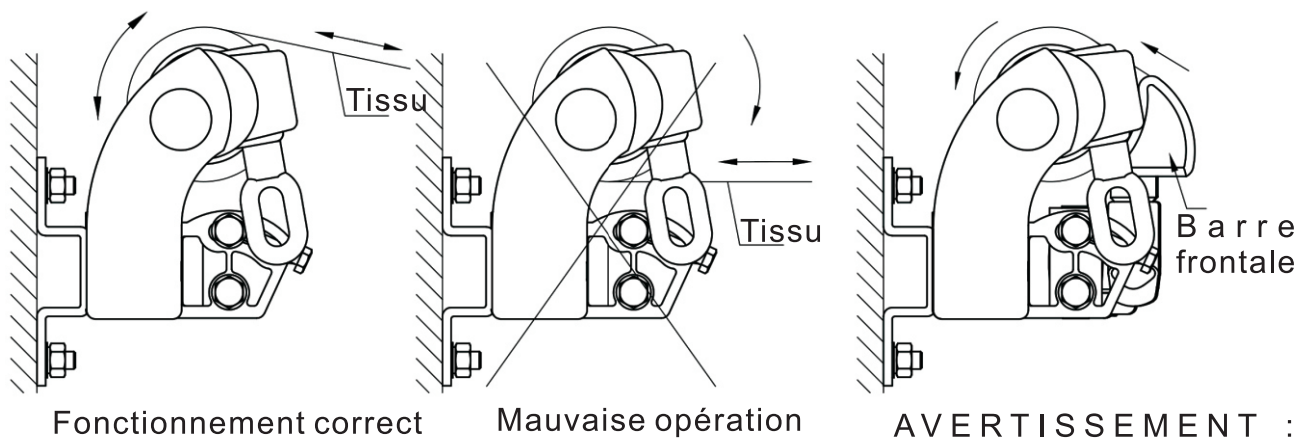

Fonctionnement correct

Mauvaise opération

AVERTISSEMENT :
lorsque la barre frontale
touche le rouleau comme
le montre la figure,
n'essayez pas de les
rapprocher, sinon le
produit risque d'être
endommagé.

ANLEITUNG

1008 Tenda Da Sole

Istruzioni per il montaggio e la cura

IT

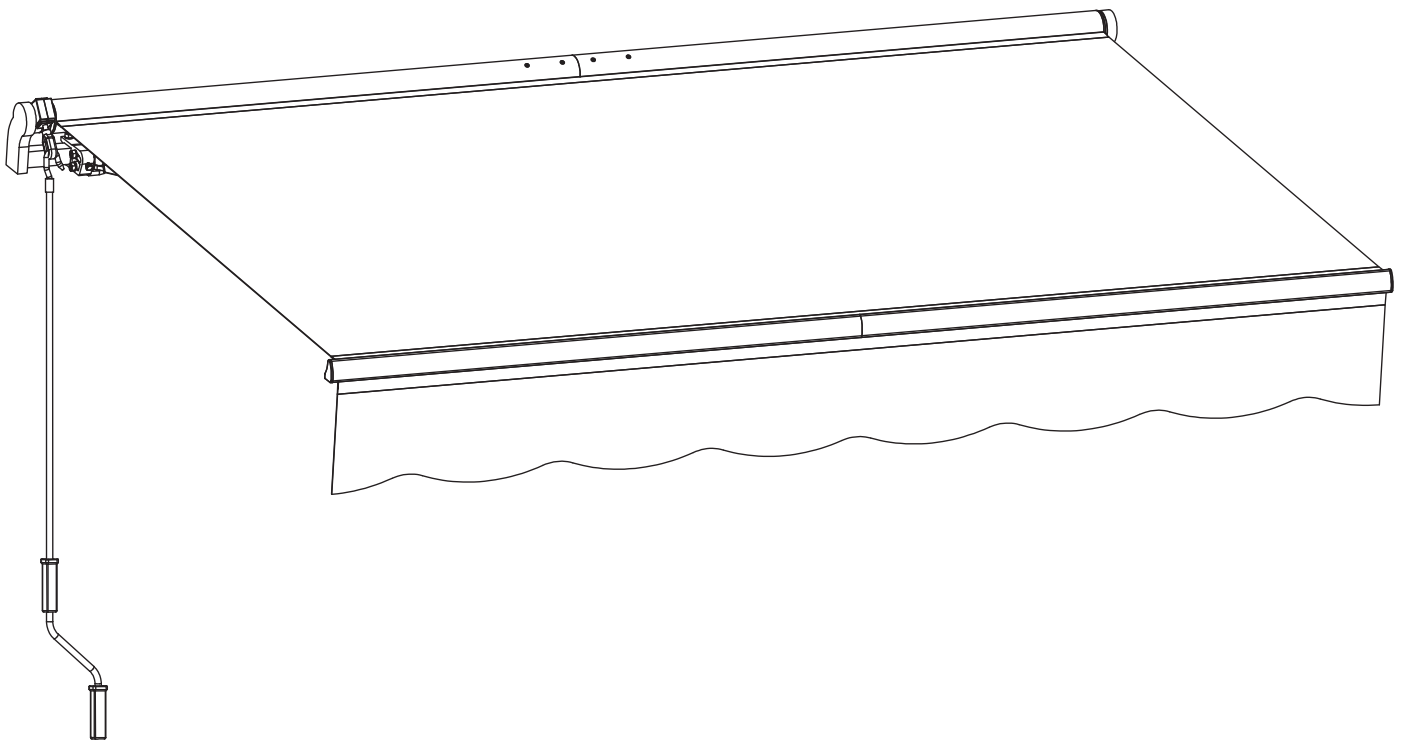

SKU:P25812-D1

IMPORTANTE

LEGGERE PRIMA DI INIZIARE IL MONTAGGIO

Seguire le istruzioni contenute nel presente manuale d'uso per garantire il corretto montaggio e la corretta manutenzione del prodotto.

Catalogo

Avviso	3
Specifiche tecniche	4
Vista esplosa	4
Elenco parti	5
Set di viti	6
Aggiuntivo.....	6
Installation Steps	7

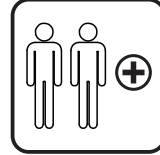
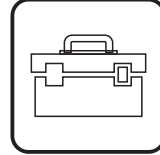
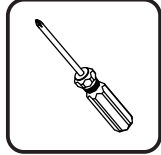
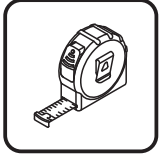
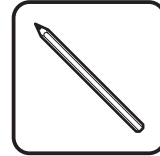
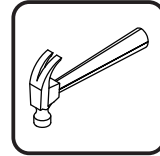
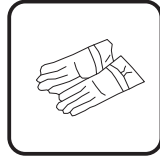
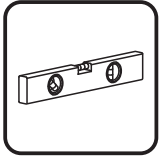

Verificare la presenza di tutte le parti e i componenti e controllare che non vi siano pezzi danneggiati prima del montaggio. In caso di parti danneggiate o mancanti, contattare il servizio clienti all'indirizzo hgeurope@outlook.com.

Contatto:

hgeurope@outlook.com

IMPORTANTE

CONSERVARE PER FUTURA CONSULTAZIONE: LEGGERE ATTENTAMENTE.

CONSIGLI

NON UTILIZZARE IN CASO DI MALTEMPO PER EVITARE DANNI.

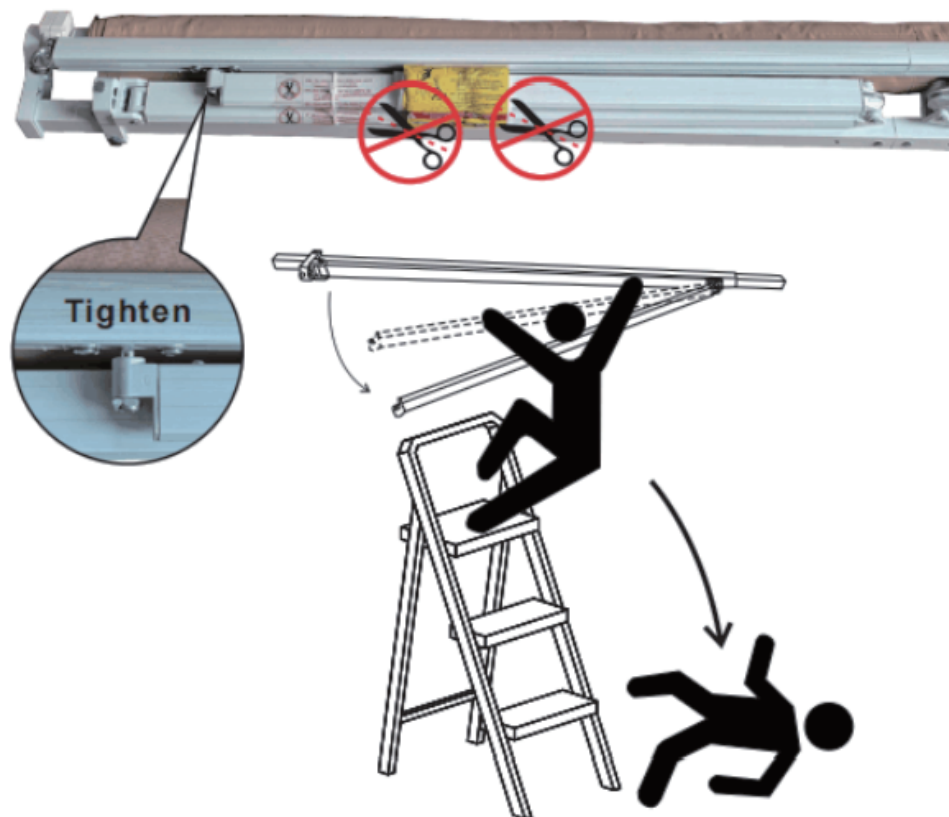

PERICOLO

TAGLIARE LE FASCETTE PRIMA DEL MONTAGGIO PUÒ CAUSARE LESIONI.

SPECIFICHE

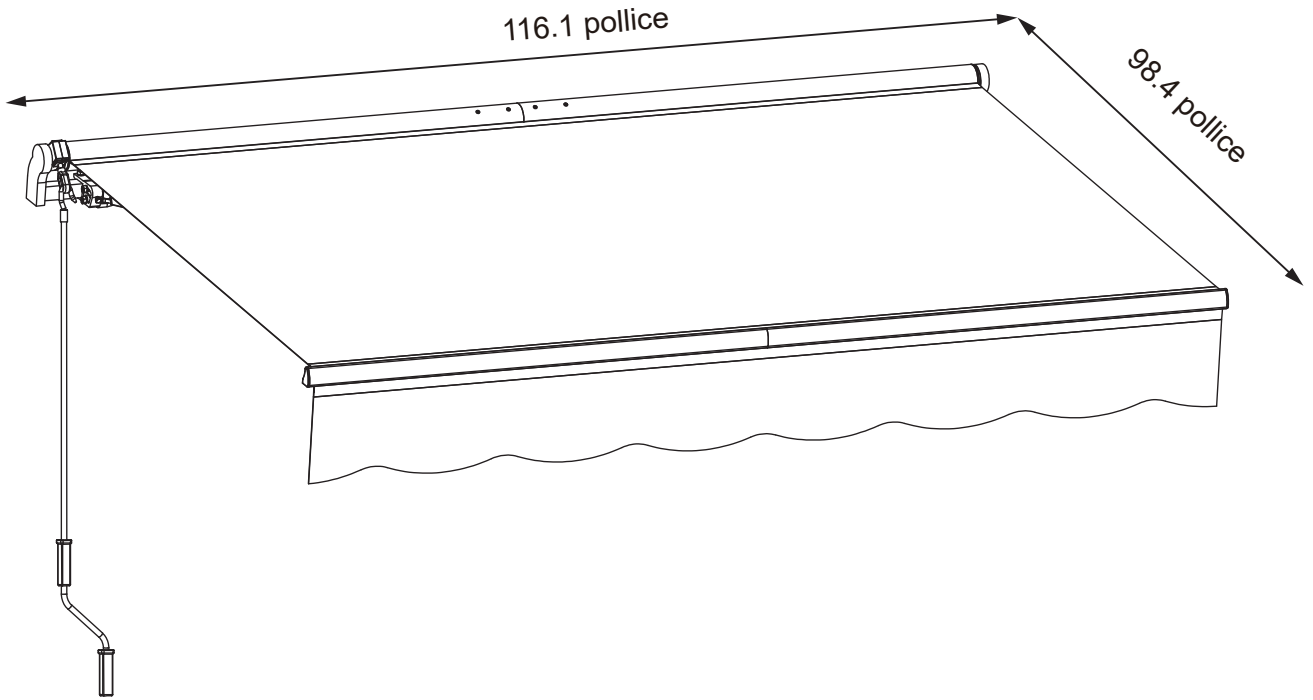





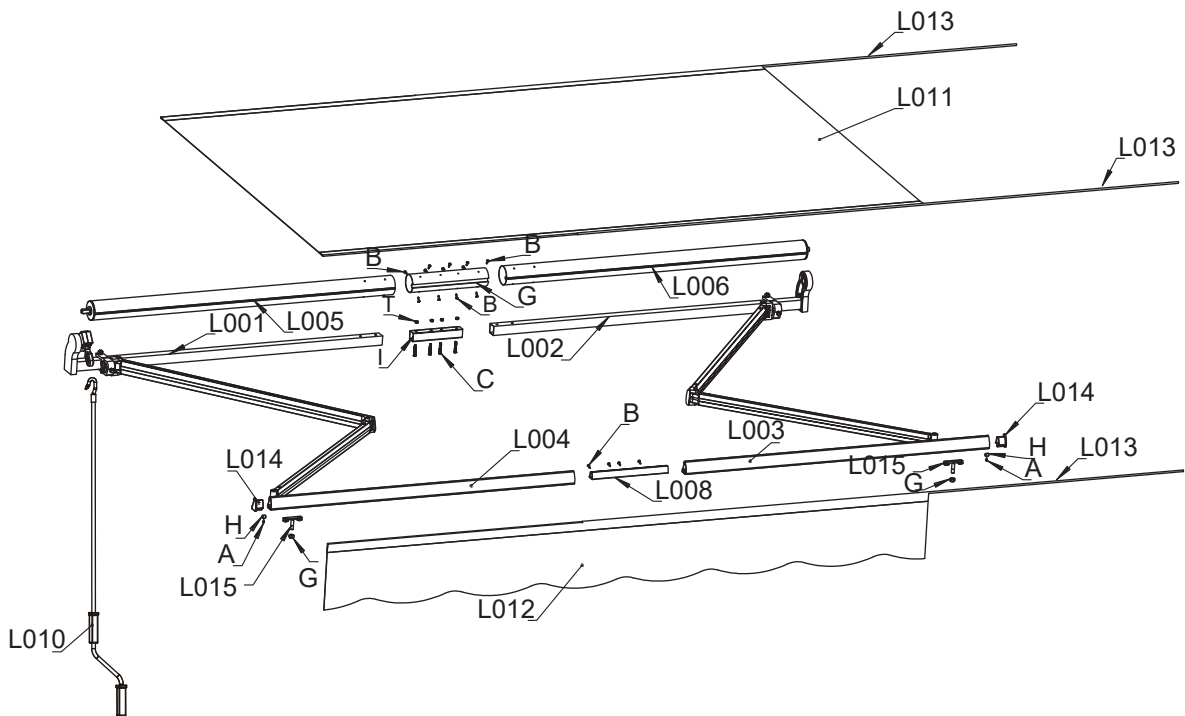



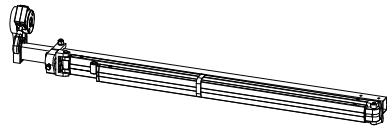
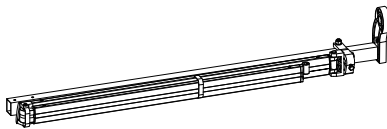

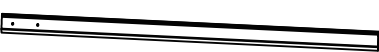
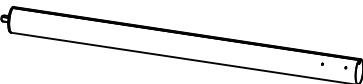
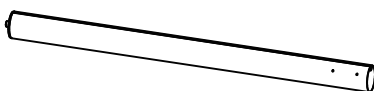
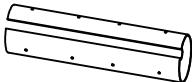
VISTA ESPLOSA

VISTA ESPLOSA

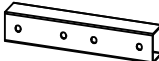

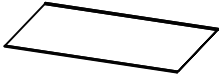

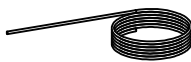

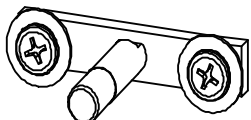
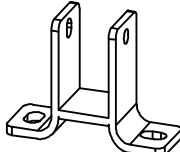

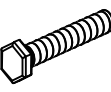

VISTA ESPLOSA

Parte	Icona	Quantità
L001		1
L002		1
L003		1
L004		1
L005		1
L006		1
L007		1
L008		1



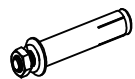

Parte	Icona	Quantità
L009		1
L010		1
L011		1
L012		1
L013		3
L014		2
L015		2
L016		2



SET DI VITE

Parte	Icona	Quantità
A	 ST3*10	2
B	 ST4*15	16
C	 M6*40	4
D	 M8*55	2
E	 M6	4

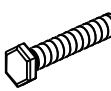
Parte	Icona	Quantità
F	 M8	2
G	 M10	2
H	 M6	2
I	 M8	4
J	 M6	4

AGGOUNTIVO

Parte	Icona	Quantità
A	 ST3*10	1
B	 ST4*15	2
C	 M6*40	1
D	 M8*55	1
E	 M6	1

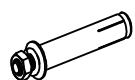
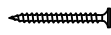
Parte	Icona	Quantità
F	 M8	1
G	 M10	1
H	 M6	1
I	 M8	1
J	 M6	1

Passo 1 Infila il filo Fabric Line e taglia il filo Fabric Line della stessa lunghezza del tessuto.

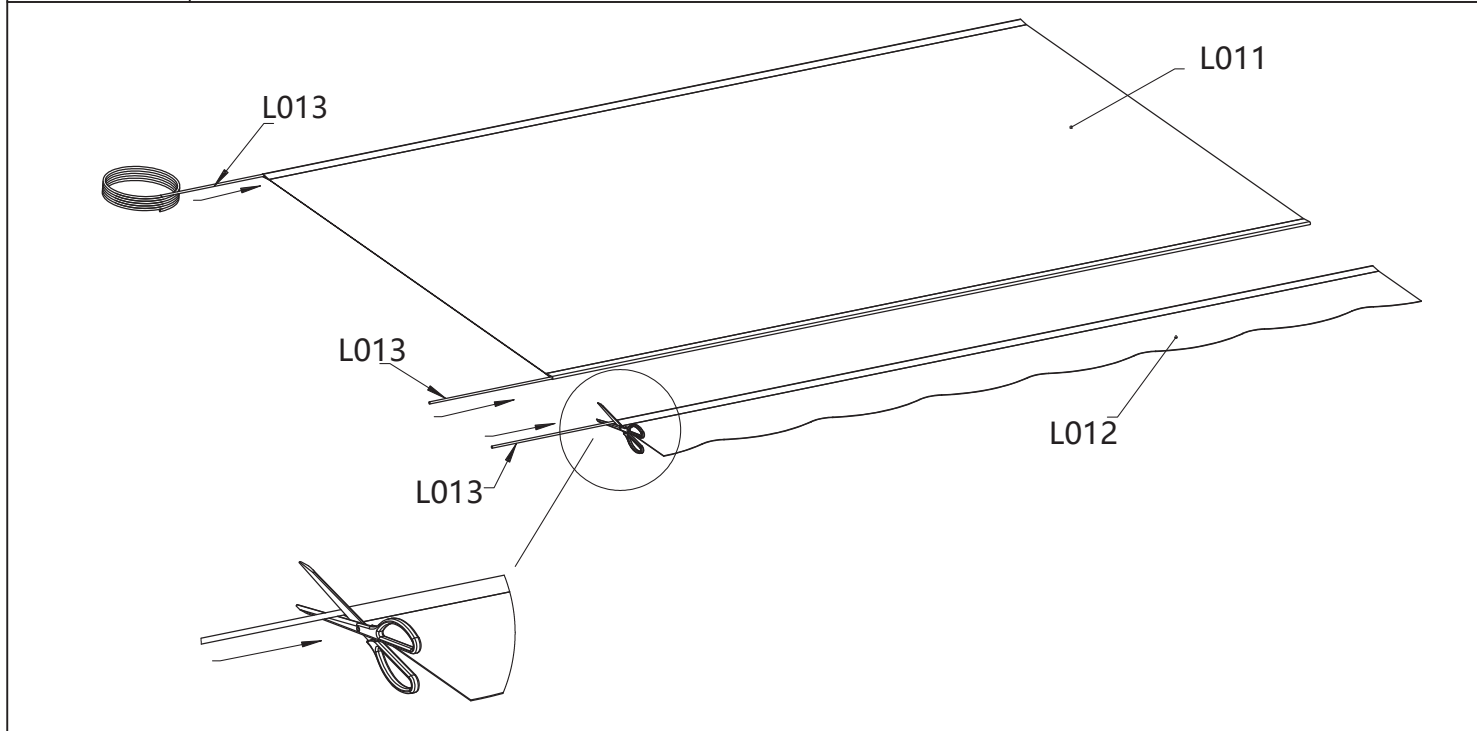

	L011 x1		L012 x1		L013 x3
--	---------	--	---------	--	---------

Passo 2 Collegamento del tubo del rullo e della barra anteriore (SINISTRA).

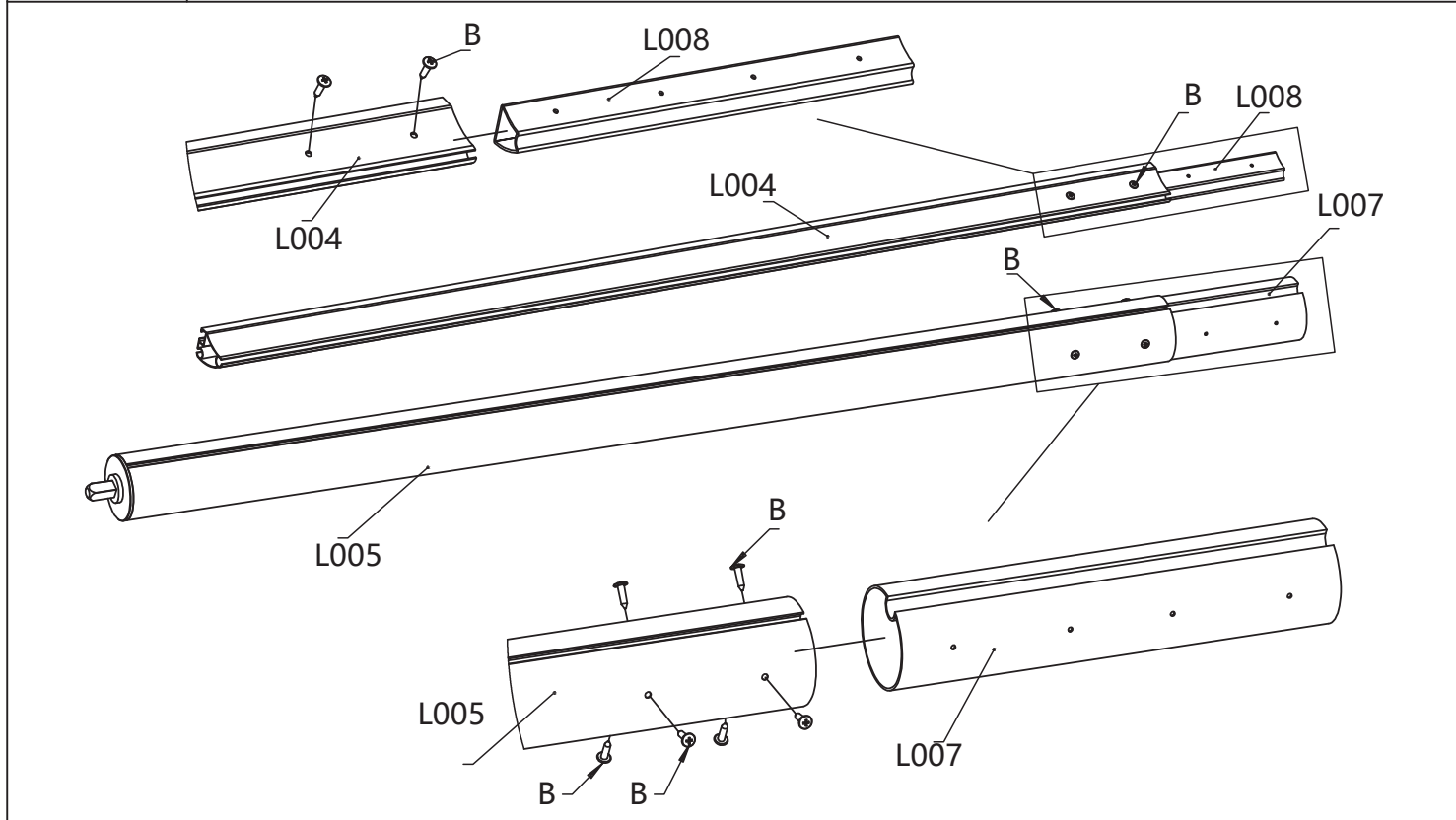

	L004 x1		L008 x1		L005 x1		L007 x1		B x8
--	---------	--	---------	--	---------	--	---------	--	------

Passo 3 Montaggio del tessuto e collegamento del rullo e della barra anteriore.

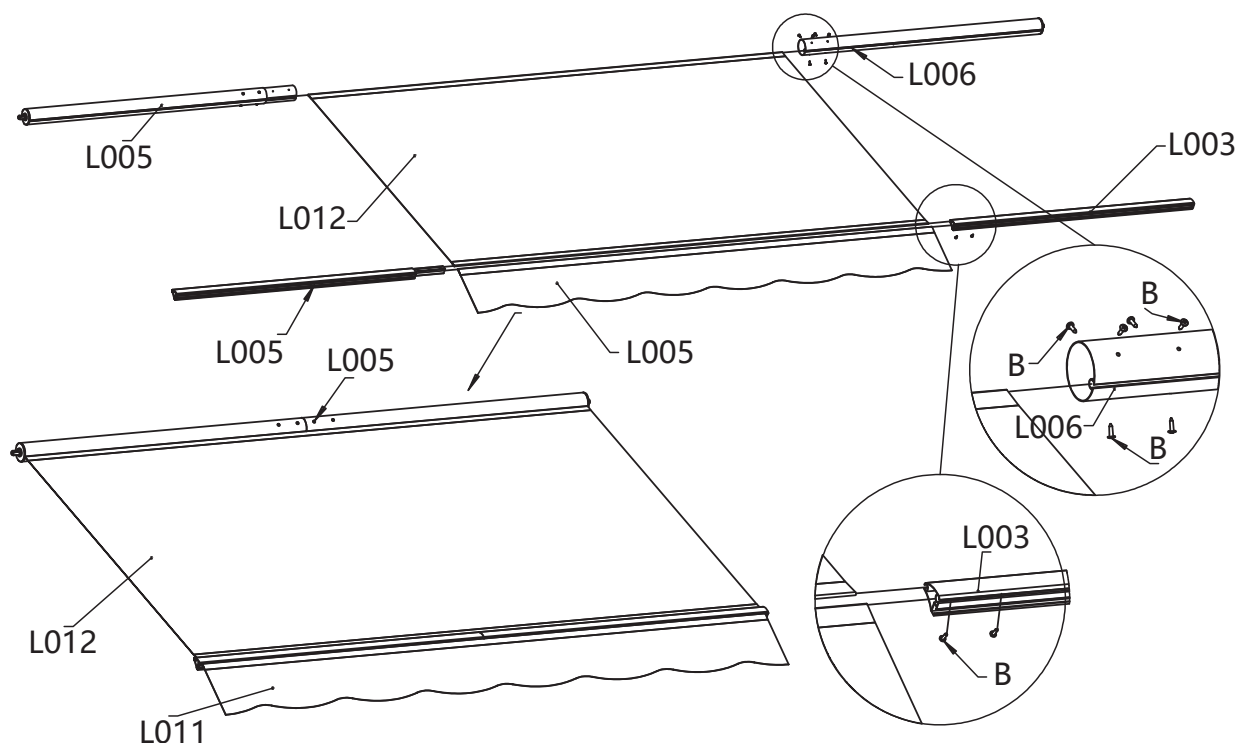

L003 x1



L006 x1



B x8

Passo 4

1. Inserire la barra del braccio nella barra anteriore.
2. Inserire la parte H nella barra anteriore e bloccarla con la vite A.
3. Toccare i tappi della barra anteriore.

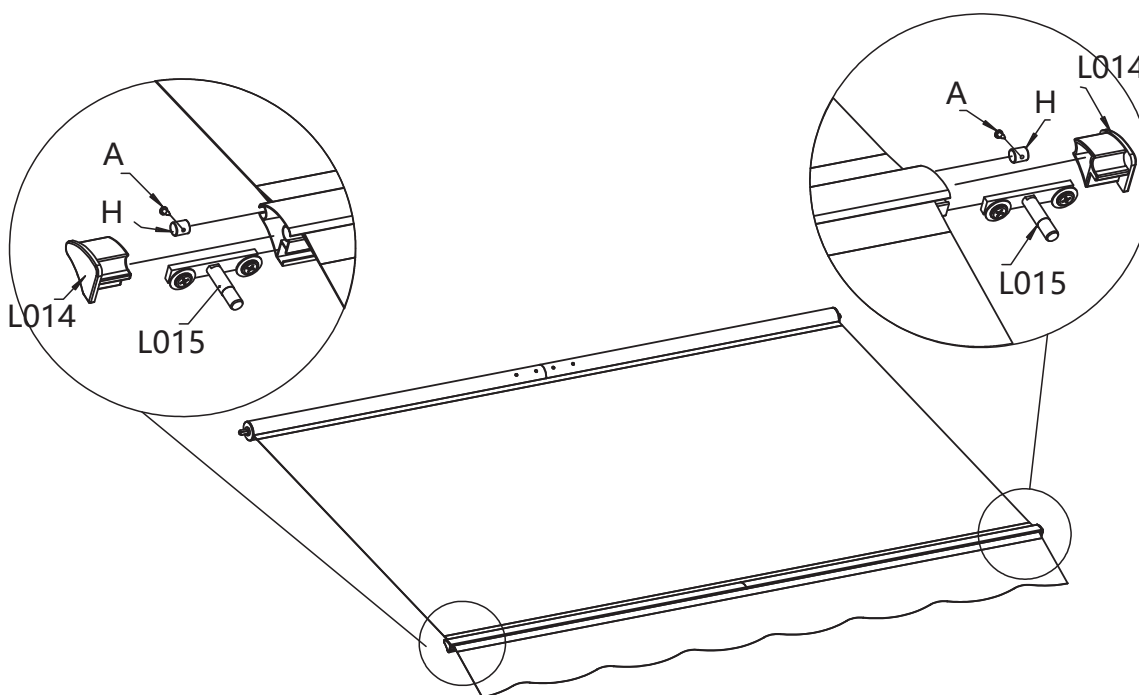

L014 x2



L015 x2

A x2

H x2

Passo 5 Arrotolare il telo della tenda il più strettamente possibile.

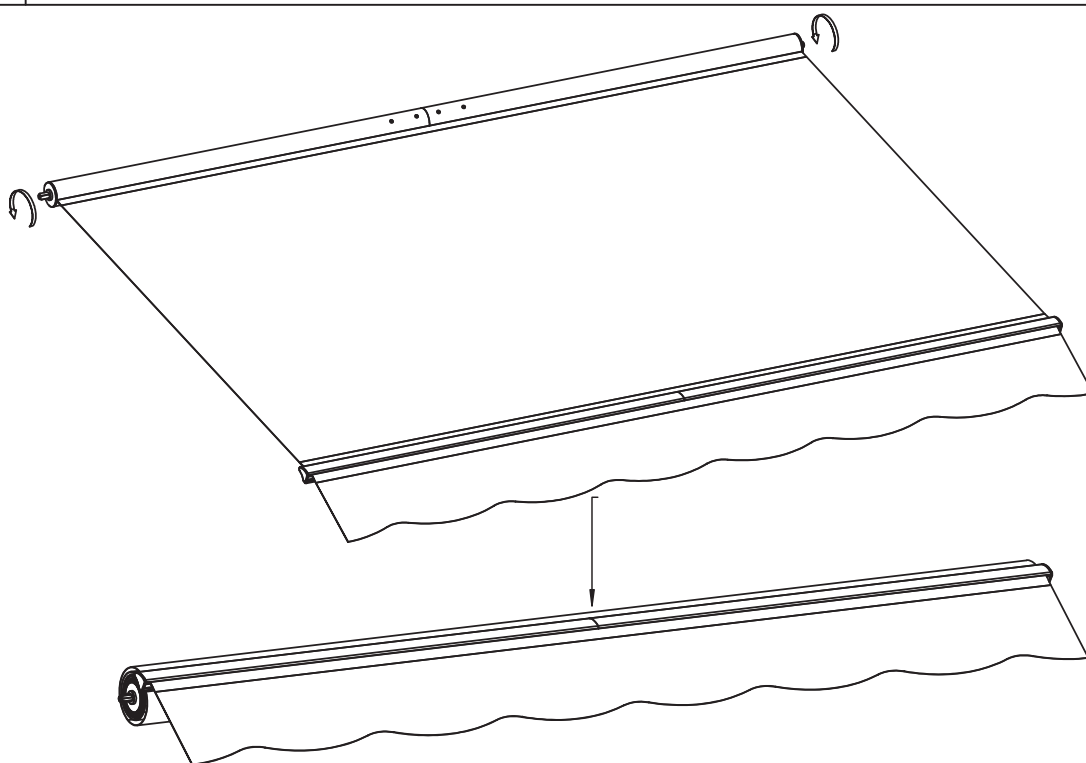

Passo 6

1. Collegare la barra di torsione sinistra (L001 e L009) e avvitare successivamente la barra di torsione destra.
2. Inserire il rullo nel foro quadrato della scatola ingranaggi e nel supporto rotondo del rullo, quindi spingere insieme la parte sinistra e quella destra.
3. Collegare e avvitare la barra di torsione destra (L002 e L009).

Inserimento

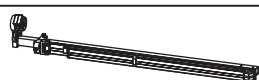
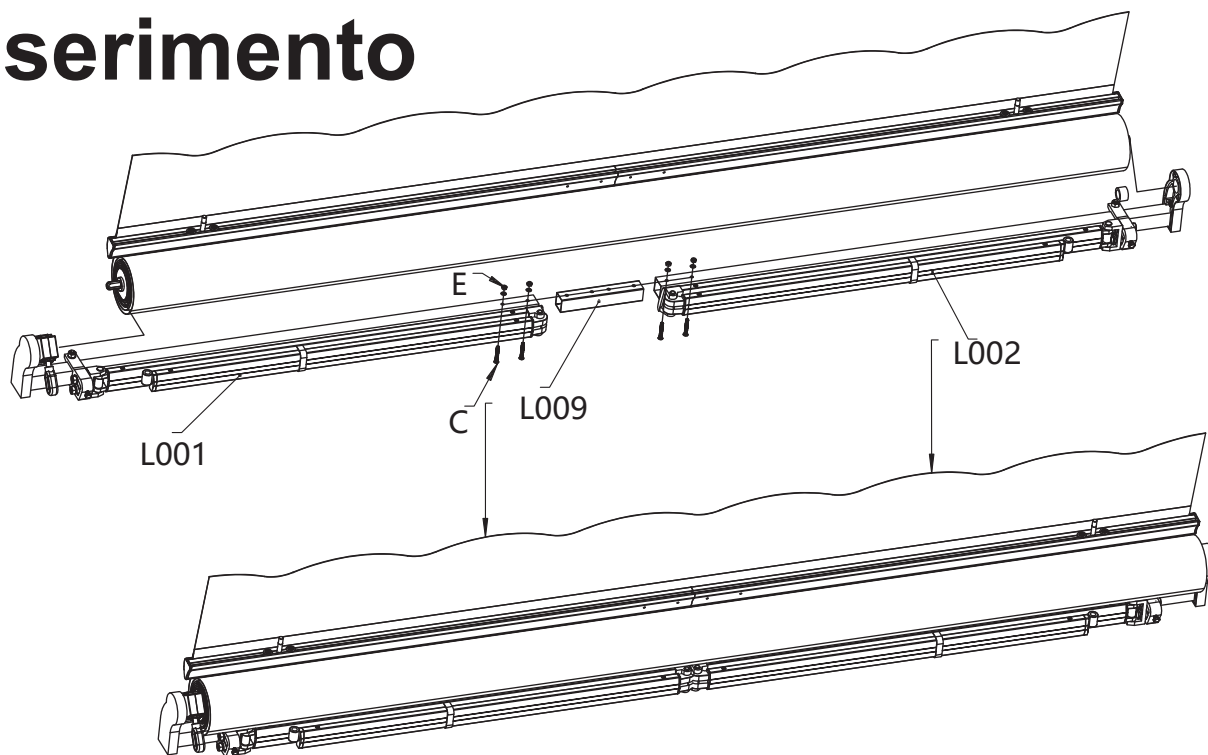

L001 x1

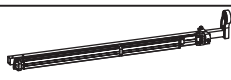

L002 x1

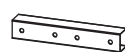

L009 x1



C x4



E x4

Passo 7

Impostazione della posizione della tenda da sole

1. Spostare il braccio di collegamento fino a quando il supporto del polso della barra anteriore non è collegato attraverso di esso.
2. Allineare la barra anteriore e il braccio e serrare la parte G della vite.
3. Quindi serrare il bullone regolabile G fino al 90% della sua capacità.

Nota: la barra anteriore è posizionata in piano con il rullo.

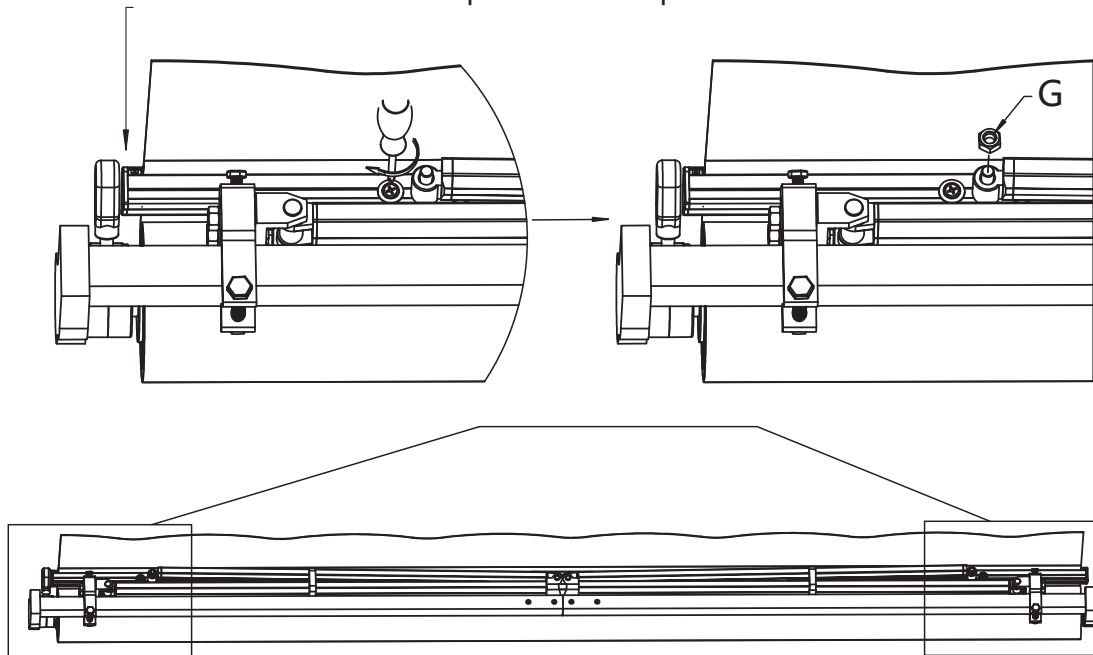

 G x2

Passo 8

Completamento del montaggio della tenda da sole

1. È possibile tagliare in tutta sicurezza le linguette di sicurezza che fissano le aste e la barra di torsione. Il montaggio della tenda da sole è completato.
2. Ora, procedere alla sezione relativa al montaggio a parete.

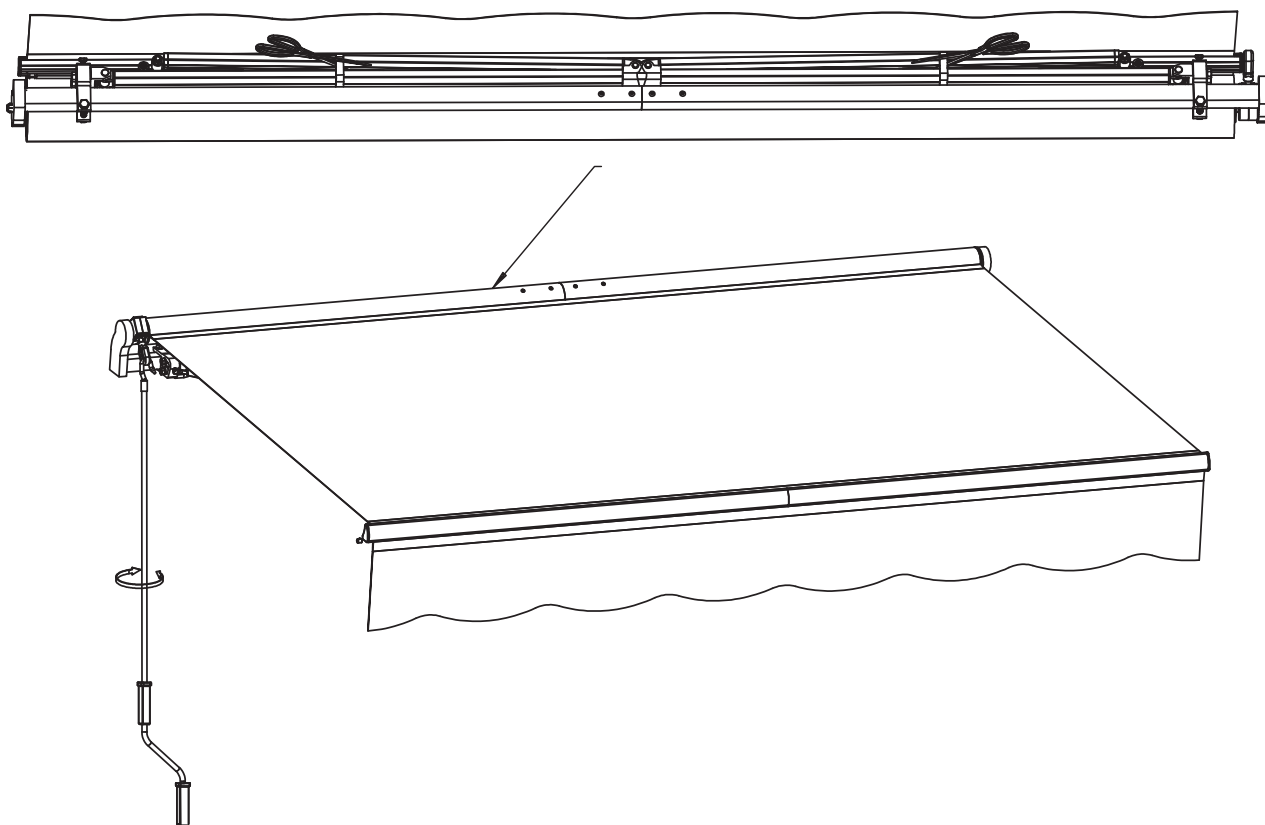

INSTALLAZIONE

Note sul montaggio a parete

Questa tenda può essere fissata su cemento armato, mattoni e legno, tuttavia questo kit fornisce solo viti adatte per il montaggio su mattoni e pareti in cemento armato.

Se si desidera fissare la tenda su legno, utilizzare bulloni a testa tonda di lunghezza e diametro adeguati per fissaggio su travi di legno. La dimensione del bullone dipende dalla dimensione del supporto in legno; questi possono essere acquistati presso un negozio di ferramenta. Consigliamo di contattare un installatore professionista per un'installazione più sicura.

Non tentare mai di fissare le staffe a parete a muri in pietra o ad altre superfici che non siano assolutamente solide!



ATTENZIONE: la corretta posizione delle staffe è l'aspetto più importante dell'installazione della tenda da sole. È fondamentale fissare tutte le staffe di montaggio a borchie, travetti, testate o altri componenti strutturali importanti.



AVVERTENZA: Il mancato fissaggio sicuro di tutte le staffe alla parete potrebbe causare il crollo della tenda e causare lesioni personali.

Altezza di montaggio

È importante prendere in considerazione l'area di apertura della tenda prima di imbullonare i supporti a parete. Se ad esempio si desidera montarla sopra una porta del patio, lasciare almeno 20 centimetri sopra il telaio della porta e assicurarsi che la tenda non interferisca con l'apertura e la chiusura della porta. L'angolo di inclinazione durante l'apertura può essere modificato solo in minima parte, quindi tenerlo in considerazione quando si decide dove posizionare la tenda.

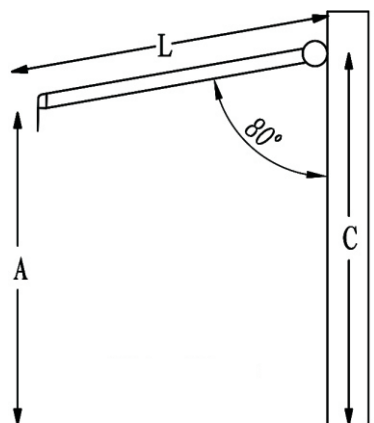

Raccomandiamo che la superficie della tenda da sole abbia un angolo di circa 80 gradi rispetto alla parete quando è aperta.

- **Altezza di installazione consigliata:** 20-30 centimetri.
- **L'angolo di inclinazione ideale (quando completamente estesa) è già stato impostato in fabbrica,** quindi potrebbe non essere necessario modificarlo.
- **La tenda da sole ha un'inclinazione** di 60 centimetri verso il basso, o 15 gradi.

CALCOLI:

È possibile utilizzare la seguente formula per calcolare l'angolo appropriato.

$$C = A + 0,17 * L$$

A = altezza desiderata della barra anteriore

L = lunghezza del braccio teso

C = altezza delle staffe a parete

PASSO 1: Misurazione del sito di montaggio

1. Misurare la lunghezza della tenda lungo la parete dove si intende installarla. Questa linea sarà il punto più alto della tenda da sole e si allineerà con la parte superiore delle staffe a parete. Usa una livella per tracciare una linea con il gesso su tutta la lunghezza.

2. Importante: Controllare che la linea sia completamente a livello.

3. Accertarsi che la linea sia centrata sulla porta del patio, sulla finestra o su altre strutture, se applicabile.

4. Ora che si dispone di una linea retta e centrata, misurare il punto centrale e contrassegnarlo. In questo punto verrà installata la staffa della parete centrale.

5. Prendere una staffa a parete e posizionarne la parte superiore, completamente orizzontale, sotto la linea, come mostrato nello schema seguente. Con un gesso o una matita, contrassegnare la posizione di tutte le staffe a parete e i relativi fori dei bulloni.

Tende da sole < 10,8 piedi	Richiede solo 2 staffe a parete in totale: Una per ogni estremità delle barre di torsione.
Tende da sole da 10,8 - 14 piedi	Richiede 3 staffe a parete in totale: Una per ogni estremità e una al centro.
Tende da sole da 14,5 - 20 piedi	Richiede 4 staffe a parete in totale: Una per ogni estremità e due al centro.

Staffa a parete livellata con la linea orizzontale

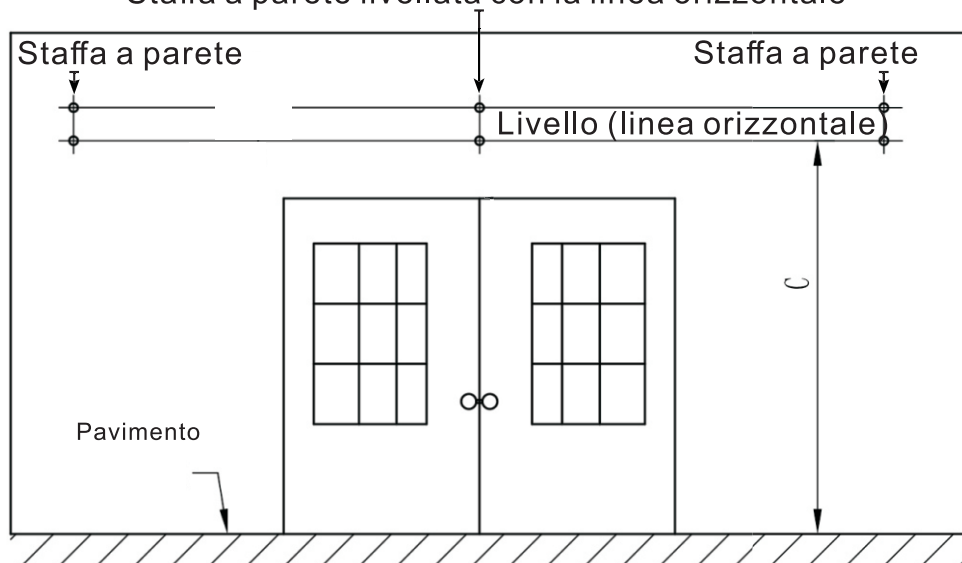

PASSO 2: Praticare i fori dei bulloni

1. Ora che si dispone di una linea dritta e piana attraverso la parete con le posizioni delle staffe a parete e i relativi fori dei bulloni contrassegnati, è necessario praticare dei fori per montare le staffe.

2. Utilizzando una punta da trapano per muratura da 14 mm, praticare il primo foro del bullone di circa 4 pollici (9 centimetri) di profondità, come mostrato nello schema. I fori vanno praticati su mattoni pieni o calcestruzzo per offrire il supporto necessario per la tenda.

3. Praticare i fori rimanenti esattamente come indicato al punto 2.

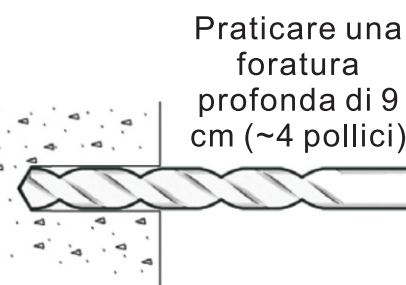

!! IMPORTANTE: Tutti i fori dei bulloni devono essere allineati verticalmente e orizzontalmente per garantire che la tenda sia dritta.

Se non si è certi, ricontrollare l'allineamento prima della foratura. **IMPORTANTE:** Il diametro e la profondità dei fori di montaggio devono essere delle stesse dimensioni dei bulloni a espansione.



PASSO 3: Preparazione per il montaggio

1. Dopo aver praticato tutti i fori, inserire i bulloni a espansione.
2. Potrebbe essere necessario inserire i bulloni con un martello di legno (o altro materiale non metallico).



Se è necessario un martello per l'installazione, si consiglia di posizionare il dado sulla vite (allentato) prima di martellare per evitare di danneggiare le filettature dei bulloni.

3. Assicurarsi che i bulloni siano saldamente in posizione, ma lasciarli fuoriuscire dalla parete di circa 1 pollice o meno, in modo tale che la staffa a parete possa essere installata su di essi.

4. Serrare saldamente i bulloni con una chiave esagonale da 19 mm. Si consiglia di utilizzare la chiave esagonale con un'estremità chiusa piuttosto che un'estremità aperta per evitare di danneggiare il dado, in caso di slittamento.

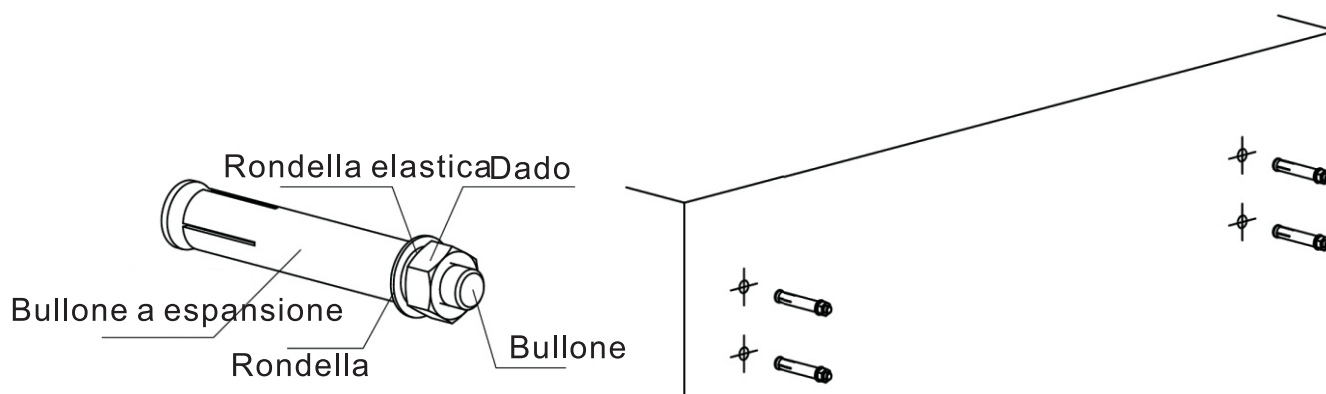

PASSO 4: Montaggio delle staffe a parete

1. Ora che i bulloni sono saldamente nella parete, rimuovere i dadi che non sono posizionati saldamente sui bulloni.

2. Posizionare una staffa a parete su un set di bulloni. Questa dovrebbe essere facile da montare se i fori dei bulloni sono allineati correttamente.

3. Quando la staffa a parete poggia sui bulloni, posizionare una rondella sul bullone, quindi fissarla con un dado, come mostrato nello schema.

4. **Le staffe DEVONO essere posizionate saldamente sulla parete.** In caso di movimento, è necessario serrare maggiormente.

5. Ripetere questa operazione per ciascuna staffa a parete. Una volta fatto questo, tutte le staffe saranno saldamente in posizione.

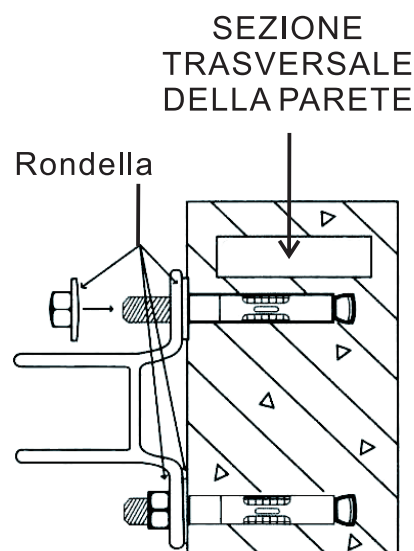

PASSO 5: Montaggio della tenda

1. Ora che le staffe a parete sono fissate e in posizione, è il momento di installare la tenda sulle staffe.

2. Per montare la tenda sono necessarie almeno due scale o sedie robuste.

3. Posizionare i bulloni a espansione originali sulle staffe a parete e serrarli.

4. Infine, fissare tutti i bulloni a espansione.

5. Utilizzando la manovella manuale o un motorino (se applicabile), aprire completamente la tenda. La barra anteriore deve essere a livello.

6. **Congratulazioni! La tenda è installata. Una volta soddisfatti dell'altezza della barra anteriore (passo della tenda da sole), rilassatevi e godetevi la vostra tenda! In caso contrario, continuare a leggere.**

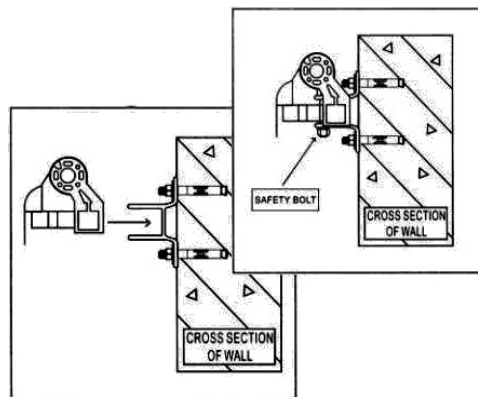

☺ INSTALLAZIONE OPZIONALE

REGOLAZIONE DEL PASSO/ANGOLO DELLA TENDA

Ogni tenda è dotata di un passo preimpostato (angolo) considerato ideale. Tuttavia, se è necessario effettuare una regolazione, è possibile farlo in pochi semplici passaggi.

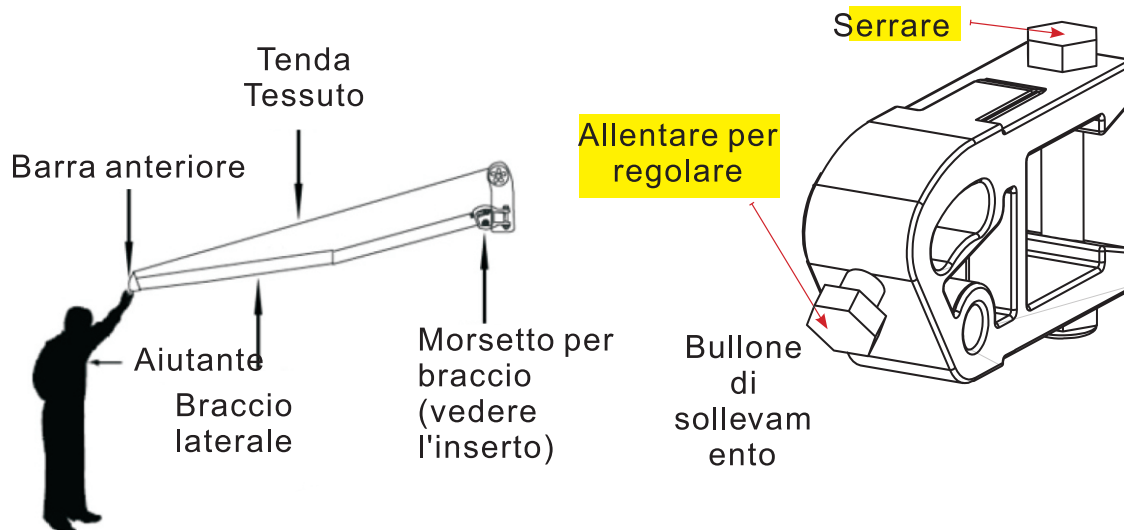

!! IMPORTANTE: L'innalzamento della barra anteriore ridurrà l'inclinazione (angolo) del tessuto, aumentando così il rischio di infiltrazione di acqua piovana nel tessuto. Per evitare che la tenda collassi a causa del peso dell'acqua piovana, è necessario ritrarla quando non è sorvegliata. Il mancato rispetto di questa precauzione potrebbe causare la rottura della tenda o lesioni personali.

Nota: Assicurarsi che la barra anteriore sia regolata in modo da essere perfettamente orizzontale. Qualsiasi disallineamento causerà una ritrazione non corretta.

Errori comuni

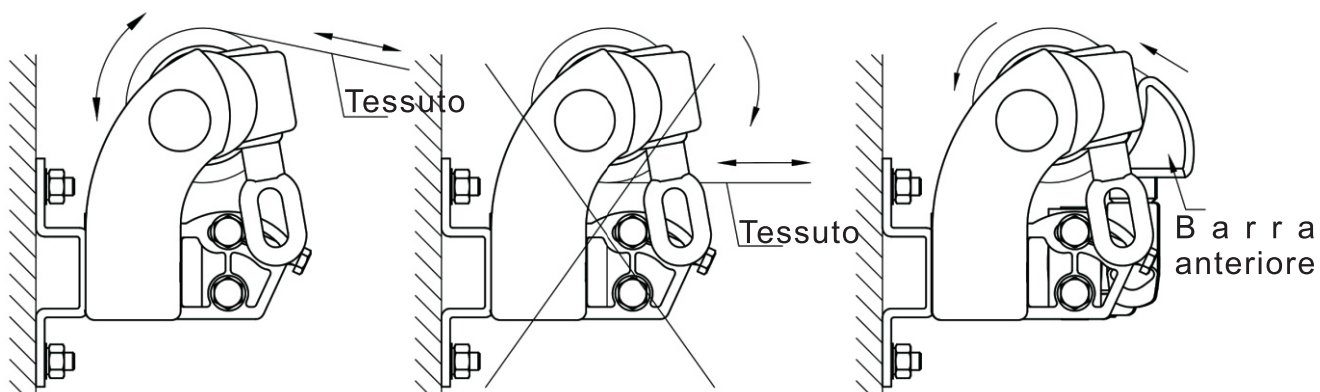

Funzionamento corretto

Funzionamento sbagliato

AVVERTENZA: Quando la barra anteriore tocca il rullo come mostrato in figura, non cercare di avvicinarli, altrimenti il prodotto potrebbe danneggiarsi.

1008 Toldo

Instrucciones de montaje y cuidado

ES

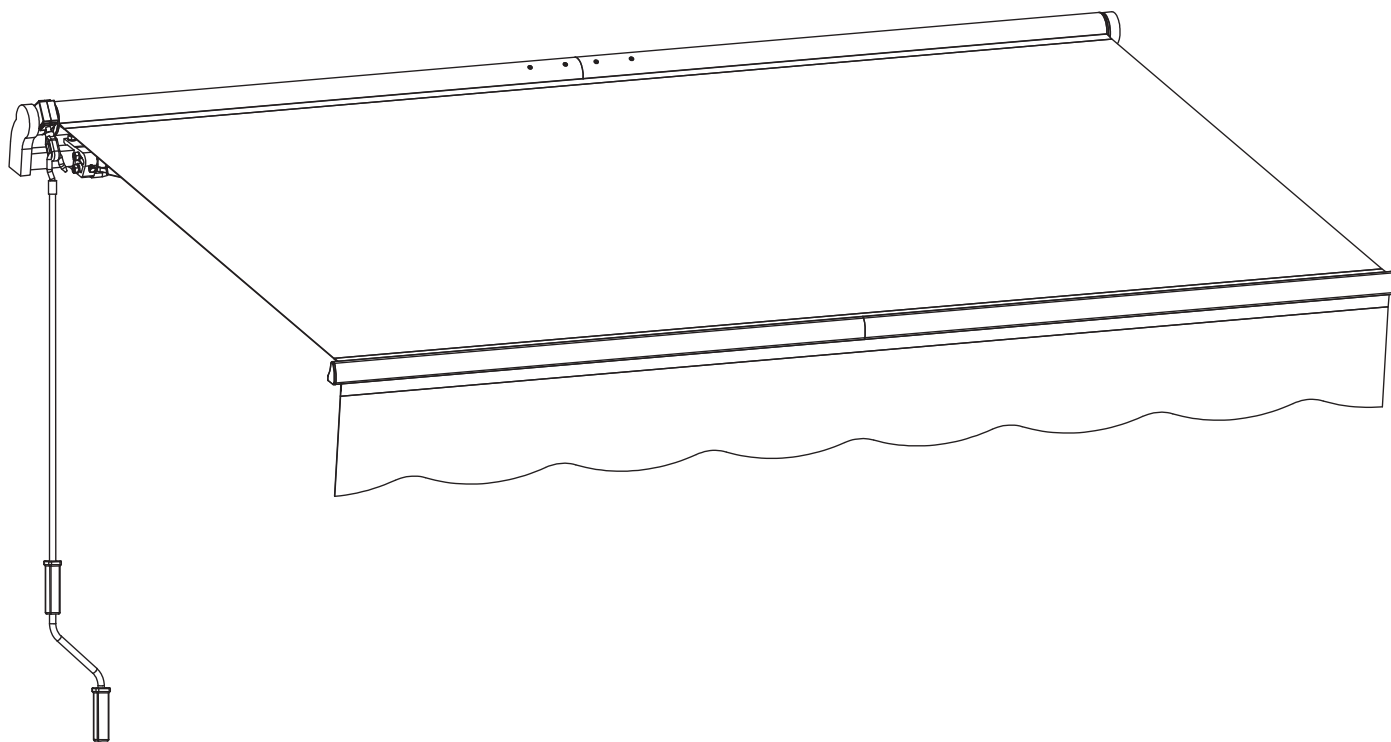

SKU:P25812-D1

IMPORTANTE

LEA ANTES DE COMENZAR EL MONTAJE

Siga las instrucciones de esta guía del usuario para garantizar el montaje y cuidado correctos de este producto.

Catálogo

Aviso	3
Especificaciones	4
Vista Explícita	4
Lista de piezas	5
Juego de tornillos.....	6
Adicional	6
Pasos de la instalación	7

AVISO

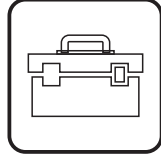
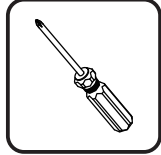
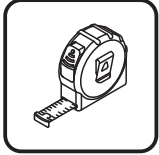
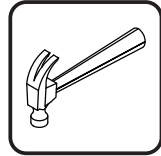
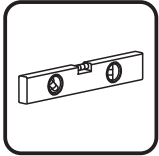

Compruebe todas las piezas y componentes presentes y compruebe si hay alguna pieza dañada antes del montaje. Si tiene alguna pieza dañada o faltante, póngase en contacto con el servicio de atención al cliente en hgeurope@outlook.com.

Contact US:

hgeurope@outlook.com

IMPORTANTE

CONSERVELO PARA FUTURAS CONSULTAS: LEA ATENTAMENTE.

CONSEJOS

NO UTILIZAR CON MAL TIEMPO PARA EVITAR DAÑOS.

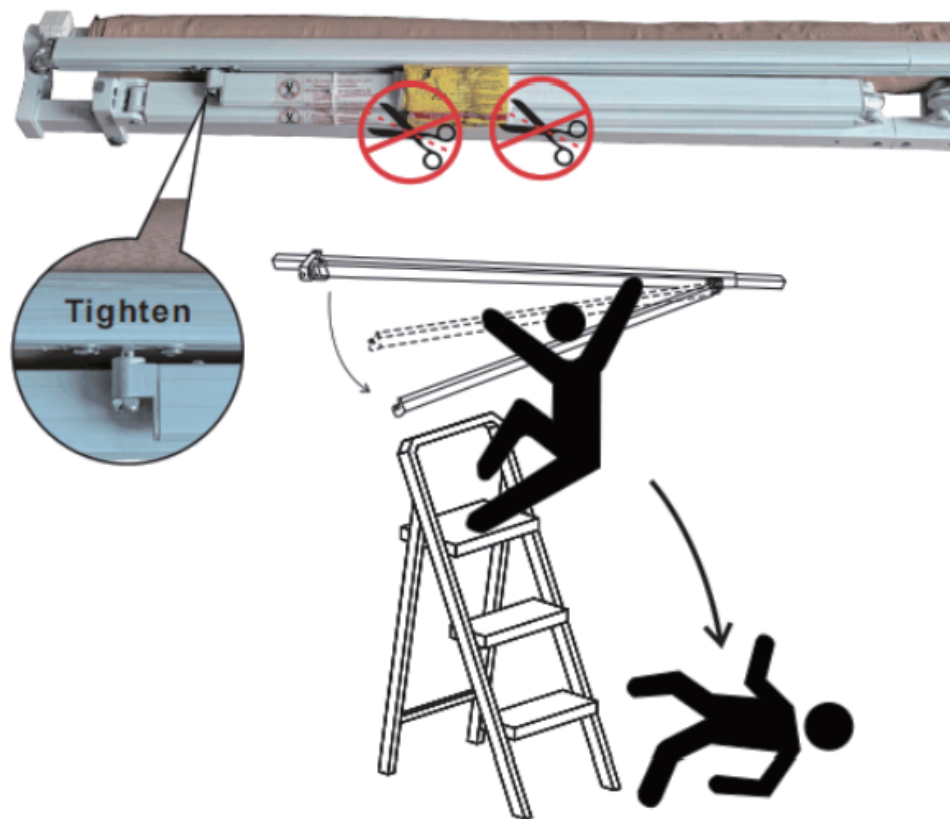

PELIGRO

CUTTING THE CABLE TIES BEFORE ASSEMBLY MAY CAUSE INJURY.

ESPECIFICACIONES

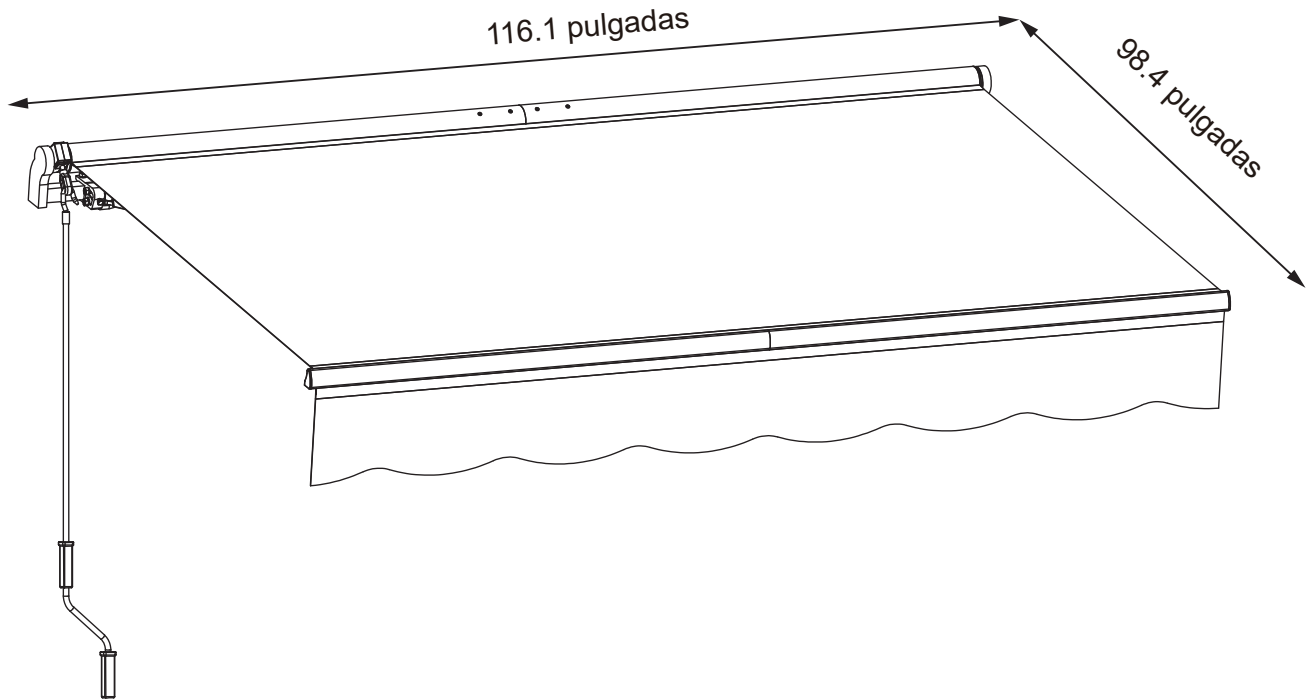





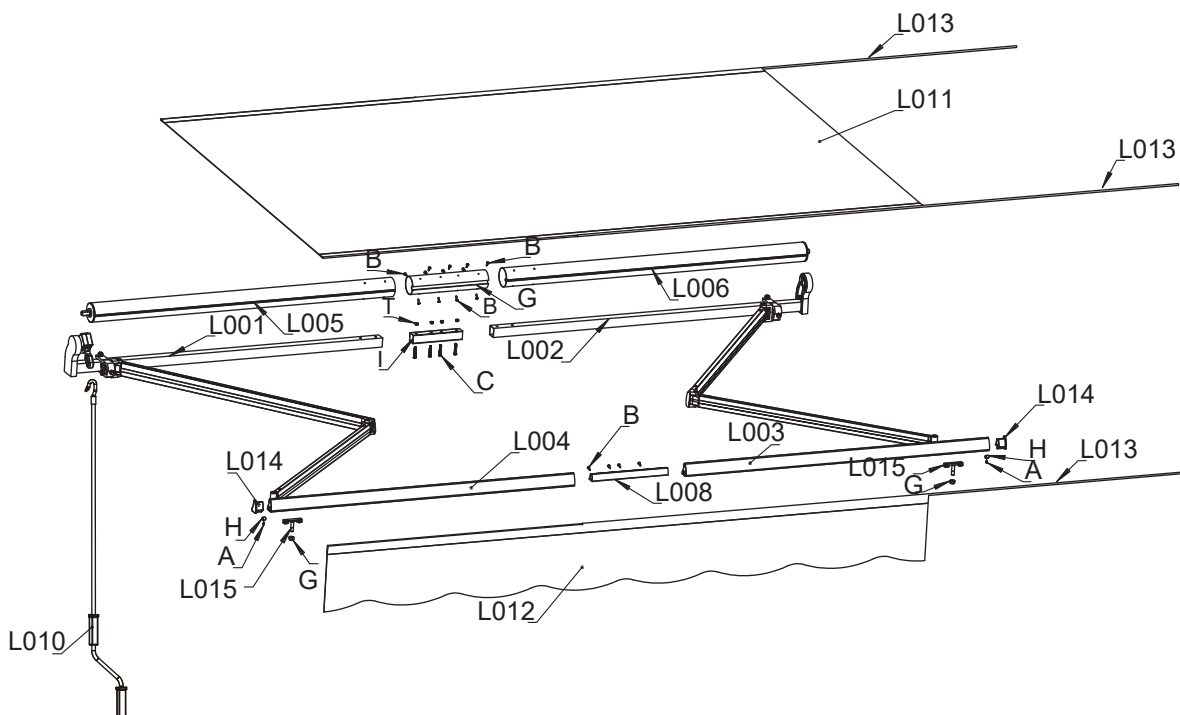



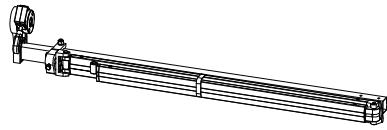
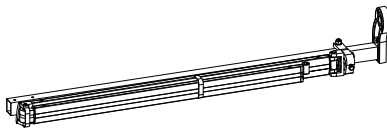

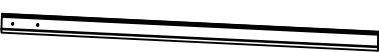
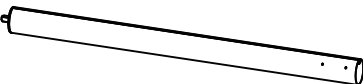
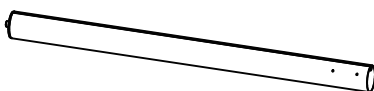
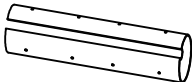
VISTA EXPLÍCITA

VISTA EXPLÍCITA

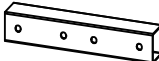

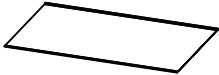

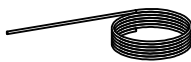

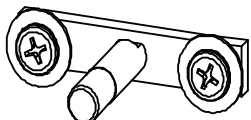
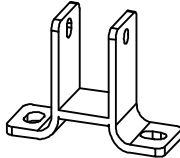

LISTA DE PIEZAS

Pieza	Icono	Cantidad
L001		1
L002		1
L003		1
L004		1
L005		1
L006		1
L007		1
L008		1

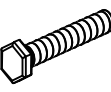



Pieza	Icono	Cantidad
L009		1
L010		1
L011		1
L012		1
L013		3
L014		2
L015		2
L016		2

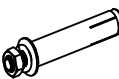
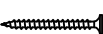

JUEGO DE TORNILLOS

Pieza	Icono	Cantidad
A	 ST3*10	2
B	 ST4*15	16
C	 M6*40	4
D	 M8*55	2
E	 M6	4

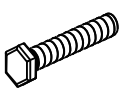
Pieza	Icono	Cantidad
F	 M8	2
G	 M10	2
H	 M6	2
I	 M10	4
J	 M8	4

ADICIONAL

Pieza	Icono	Cantidad
A	 ST3*10	1
B	 ST4*15	2
C	 M6*40	1
D	 M8*55	1
E	 M6	1

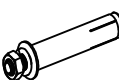
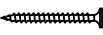
Pieza	Icono	Cantidad
F	 M8	1
G	 M10	1
H	 M6	1
I	 M10	1
J	 M8	1

Pasos de la instalación

Paso 1

Enhebre el hilo para tela y corte el hilo para tela del mismo largo que la tela.

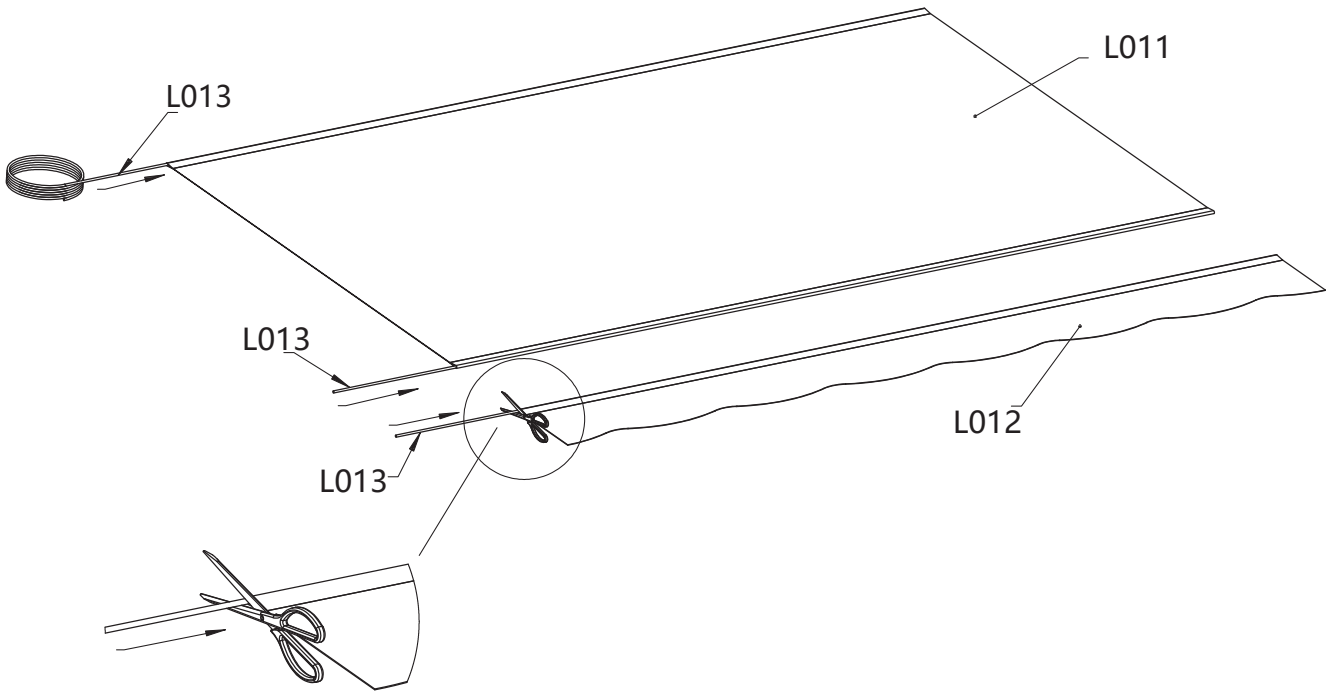

L011 x1



L012 x1



L013 x3

Paso 2

Tubo de rodillos de conexión y barra delantera (IZQUIERDA).

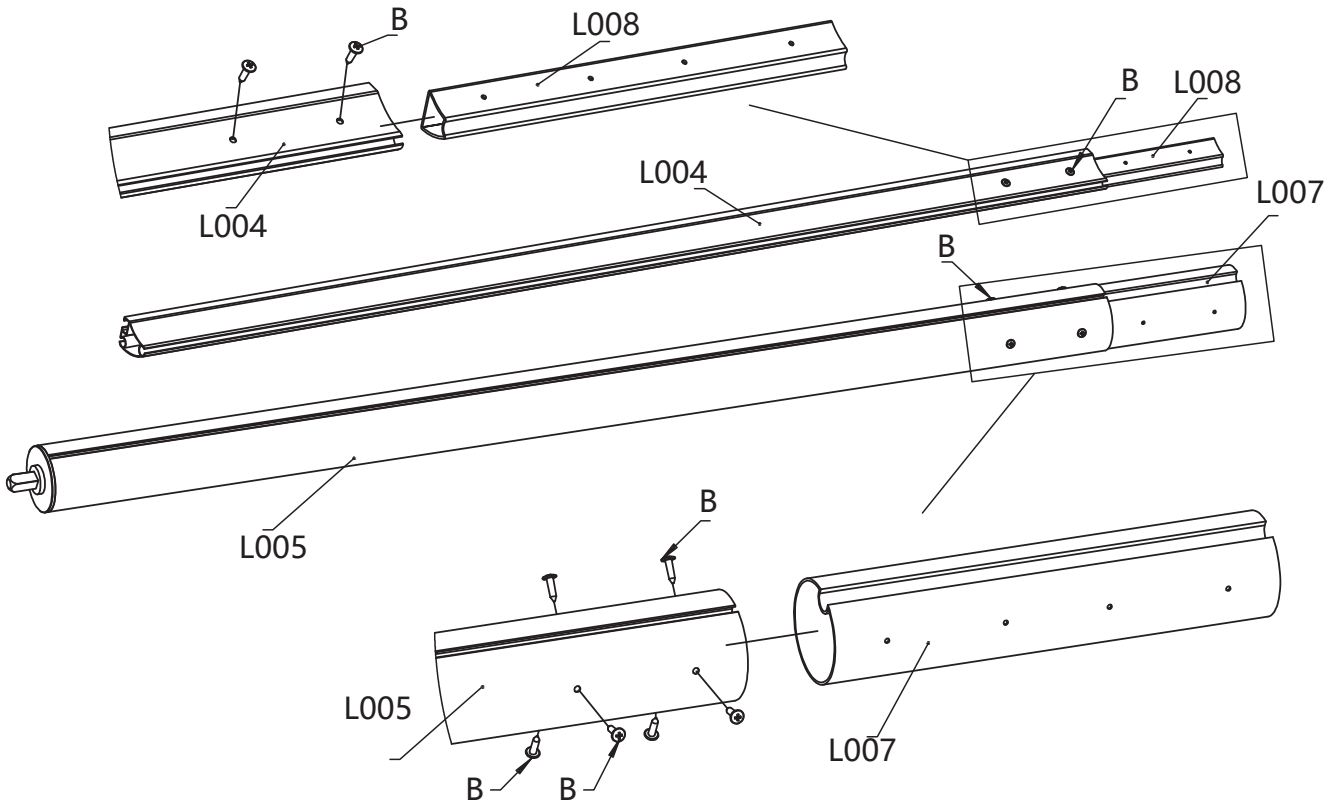

L004 x1



L008 x1



L005 x1



L007 x1



B x8

Paso 3 Montaje de la tela y conexión del rodillo y la barra delantera.

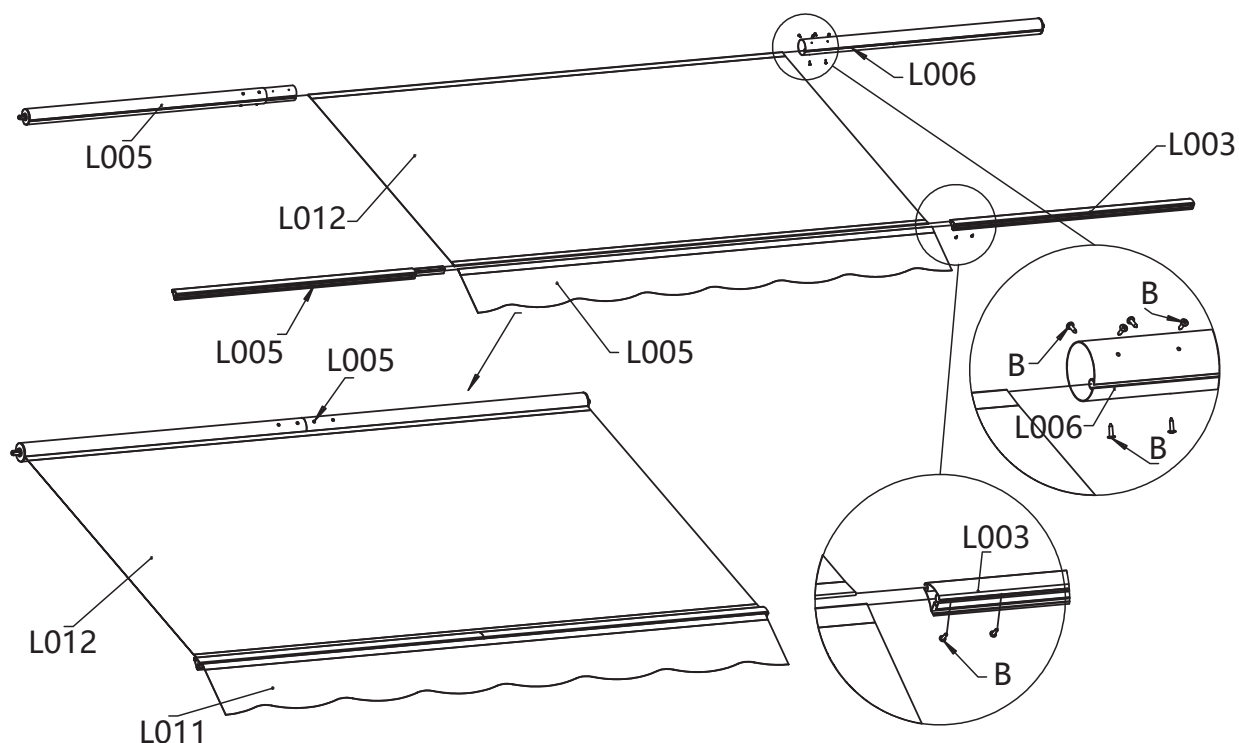

L003 x1



L006 x1



B x8

Paso 4

1. Coloque el eslabón de la barra de brazos en la barra delantera.
2. Coloque la parte H en la barra delantera y bloquéela con el tornillo A.
3. Golpee las tapas de la barra delantera.

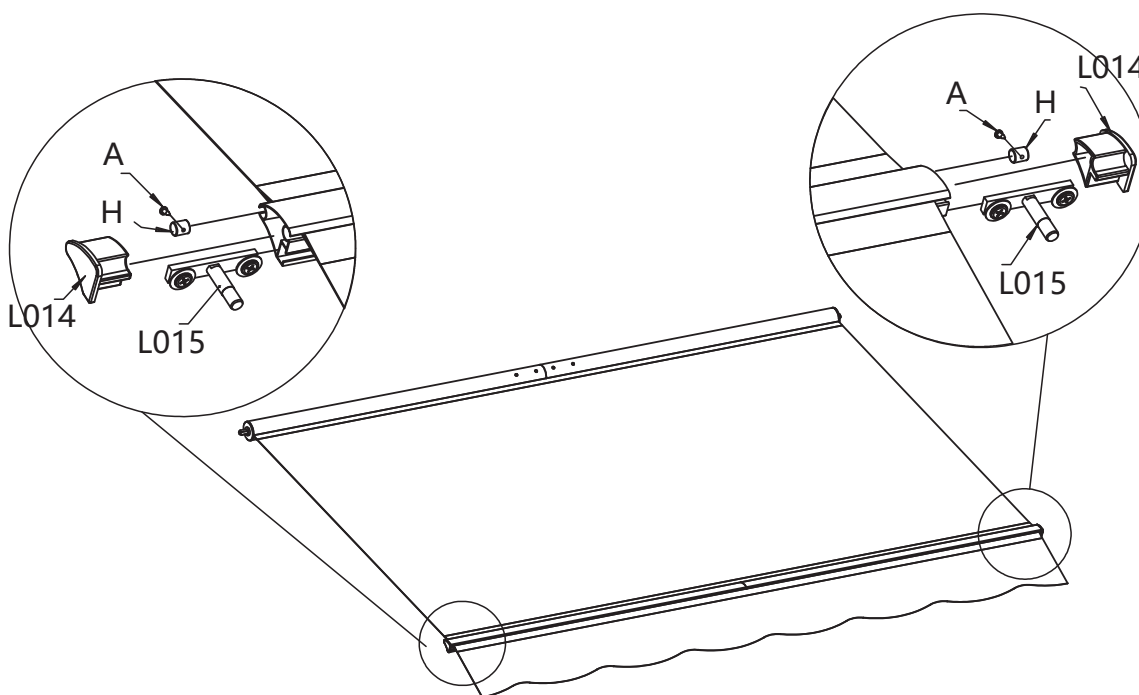

L014 x2



L015 x2

A x2

H x2

Paso 5 Enrolle el tejido del toldo lo más apretado posible.

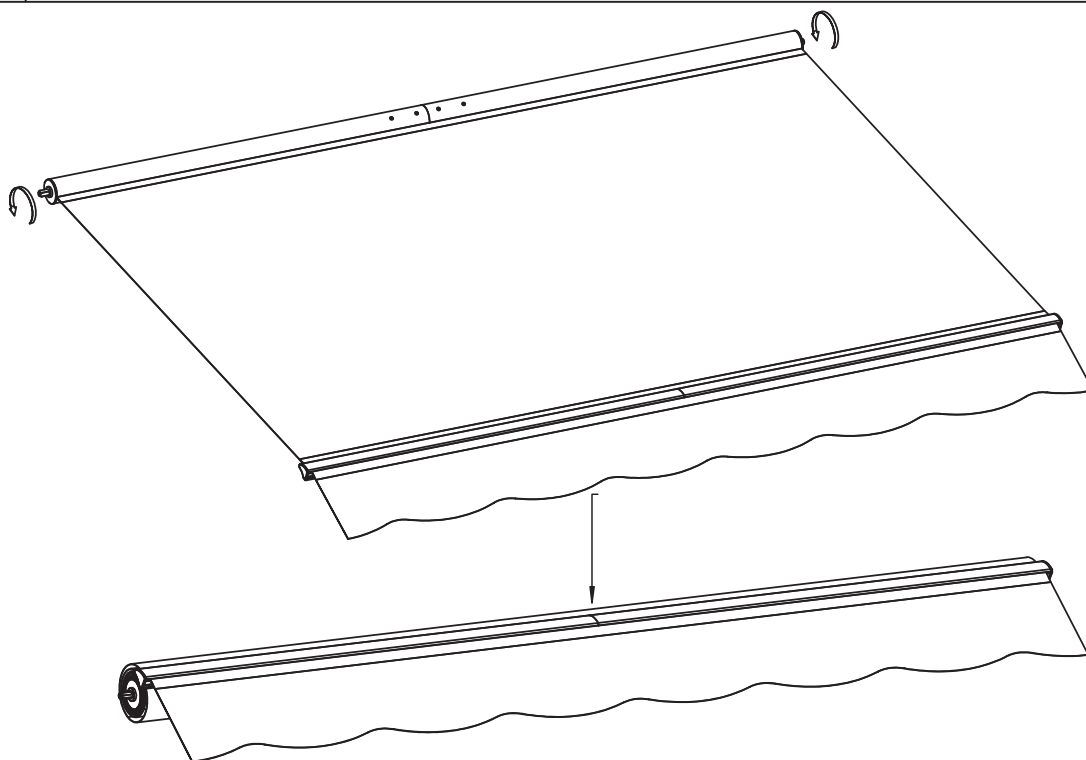

Paso 6

1. Conecte la barra de torsión izquierda (L001 y L009) y atornille la barra de torsión derecha más tarde.
2. Coloque el rodillo en el orificio cuadrado de la caja de engranajes y en la parte redonda del soporte del rodillo, luego empuje hacia la izquierda y hacia la derecha al mismo tiempo.
3. Conecte y atornille la barra de torsión derecha (L002 y L009).

Insertar

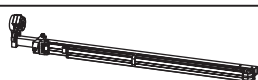
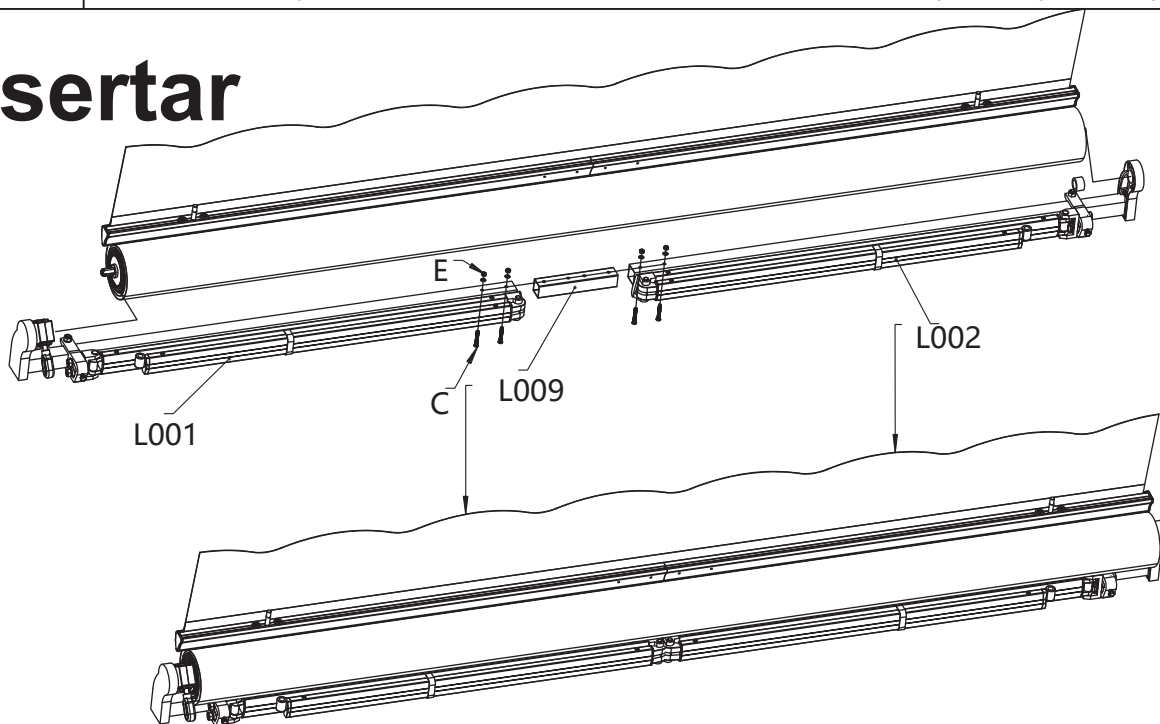

L001 x1

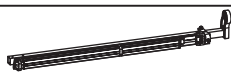

L002 x1

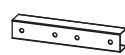

L009 x1



C x4



E x4

Paso 7

Ajuste de la posición del toldo

1. Mueva el brazo articulado hasta que el soporte de la barra delantera quede conectado a través de él.
2. Alinee la barra delantera y el brazo, y apriete el tornillo de la pieza G.
3. A continuación, apriete el perno ajustable G hasta un 90 % de su capacidad.

Nota: La barra delantera se coloca en posición horizontal con el rodillo.

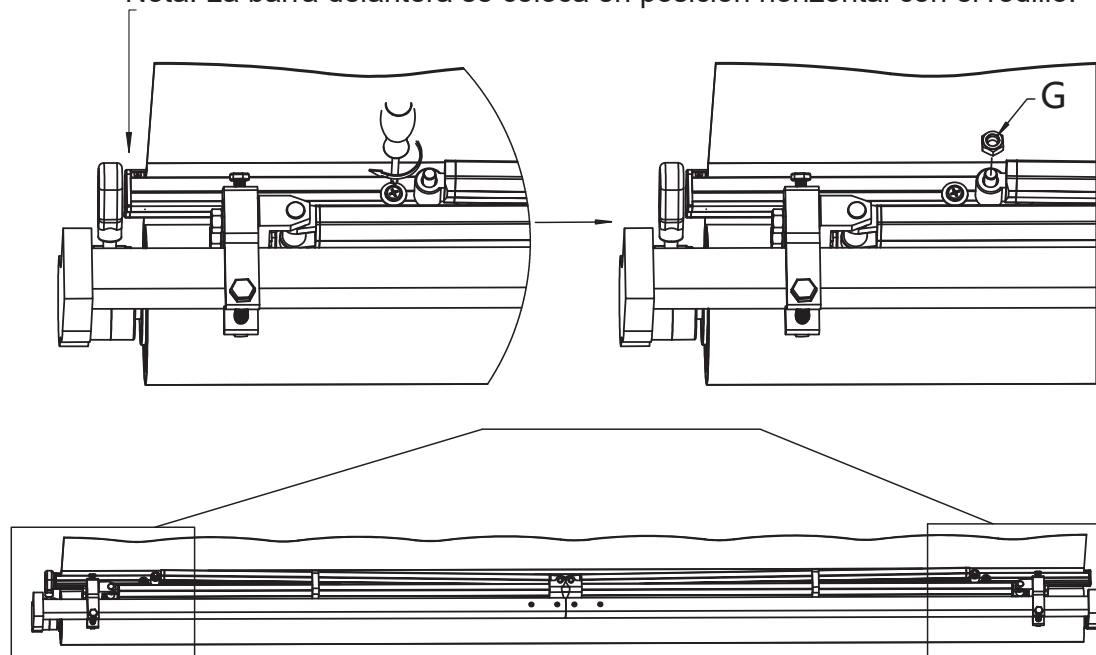

 G x2

Paso 8

Completamento del montaggio della tenda da sole

1. È possibile tagliare in tutta sicurezza le linguette di sicurezza che fissano le aste e la barra di torsione. Il montaggio della tenda da sole è completato.
2. Passare ora alla sezione dedicata al montaggio a parete.

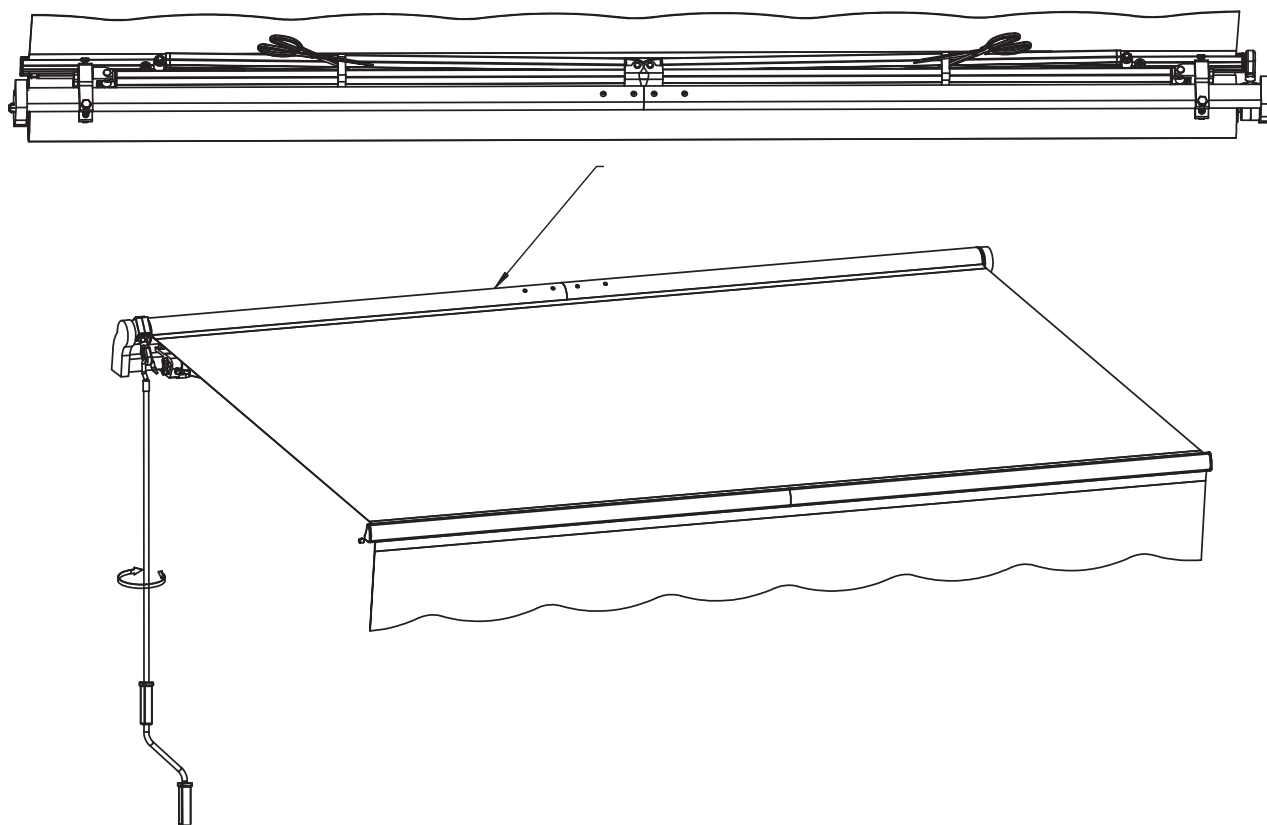

🔧 INSTALACIÓN

Notas sobre el montaje en pared

Este toldo se puede fijar a paredes de hormigón armado, ladrillo y madera. Sin embargo, este kit de toldo sólo proporciona tornillos adecuados para el montaje en paredes de ladrillo y hormigón armado.

Si desea fijar su toldo a la madera, utilice tornillos de la longitud y diámetro adecuados para fijar el toldo a los soportes de madera. El tamaño de los tornillos depende del tamaño de la madera y se pueden adquirir en una ferretería. Recomendamos un instalador profesional para una instalación más segura y protegida.

¡Nunca intente fijar los soportes de pared en pavimentos sueltos o en superficies que no sean absolutamente firmes!



CUIDADO: La ubicación correcta de los soportes es el aspecto más importante en la instalación del toldo. Es esencial que todos los soportes de montaje estén asegurados a vigas, travesaños, soportes u otros componentes estructurales importantes.



AVISO: La falta de fijación segura de todos los soportes a la pared puede provocar el colapso de la toldilla y causar lesiones personales o la muerte.

Altura de montaje

Es importante tener en cuenta la zona de inclinación del toldo antes de atornillar los soportes de pared. Si planea montarlo encima de una puerta de patio, por ejemplo, deje al menos 20 cm por encima del marco de la puerta y asegúrese de que el toldo no interfiera con la apertura y el cierre de la puerta. El ángulo de inclinación sólo se puede cambiar mínimamente, por lo que debes tenerlo en cuenta a la hora de decidir dónde colocar el toldo.

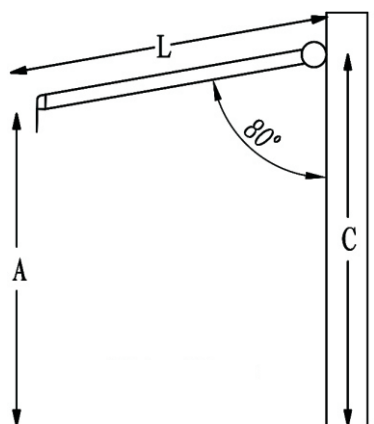

Recomendamos que la superficie del toldo esté en un ángulo de unos 80 grados con respecto a la pared cuando esté abierto.

Altura de instalación recomendada: 2,4-3,6 metros.

El ángulo de caída ideal (cuando está completamente extendido) ya se ha configurado en fábrica., por lo que puede que no sea necesario cambiar el ángulo.

El toldo tiene caída. 61 cm en pendiente, o 15 grados

CÁLCULOS:

Puede utilizar la siguiente fórmula para calcular el ángulo apropiado

$$C=A+0,17*L$$

A= La altura deseada de la barra frontal.

L= La pierna del brazo estirado.

C= La altura de los soportes de pared.

PASO 1: Medir la ubicación de montaje

1. Mide la altura de tu toldo a lo largo de la pared donde quieras instalarlo. Esta línea será el punto más alto del toldo y estará alineada con la parte superior del soporte de pared. Utilice un nivel para hacer una línea de tiza a lo largo de la distancia.
2. Importante: verifique que la línea esté nivelada en toda su longitud.
3. Asegúrese de que la línea esté centrada sobre la puerta del patio, la ventana u otra característica, si corresponde.
4. Ahora que tienes una línea recta centrada, mide el punto medio y márcalo. Aquí es donde se colocará el soporte de pared central. Aquí es donde se instalará el soporte de pared central.
5. Tome un soporte de pared y coloque su parte superior, completamente nivelada, debajo de la línea, como se muestra en el diagrama a continuación. Con tiza o un lápiz, marque la posición de todos los soportes de pared y sus orificios para tornillos.

Toldo < 3,30 m	Sólo requiere 2 soportes de pared en total: uno para cada extremo de las barras de torsión.
Toldo < 3,30-4,25 m	Requiere un total de 3 soportes de pared: uno para cada extremo y otro en el medio.
Toldo < 4,40-6 m	Requiere 4 soportes de pared en total: uno para cada extremo y dos en el medio.

Soporte de pared al ras de la línea horizontal Soporte de pared al ras de la línea horizontal

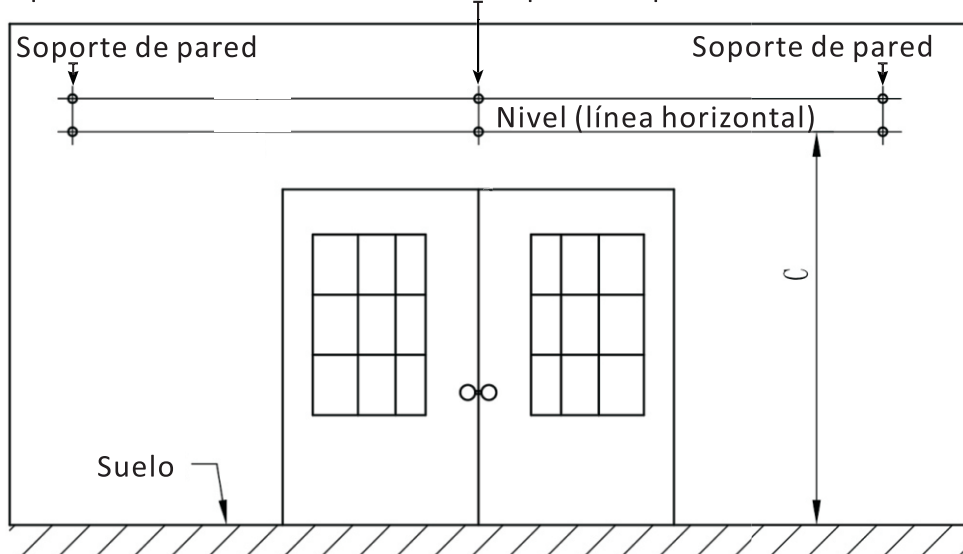

PASO 2: taladre los orificios para los tornillos

1. Ahora que tiene una línea recta y nivelada a lo largo de la pared con las ubicaciones de los soportes de pared y sus soportes marcados, taladre los orificios para montar los soportes.
2. Con una broca de 14 mm, taladre el primer orificio de unos 9 centímetros de profundidad, como se muestra en el diagrama. Esto se debe hacer utilizando ladrillo macizo o cemento para obtener el soporte necesario para el toldo.
3. Taladre los agujeros restantes exactamente como en el paso 2.

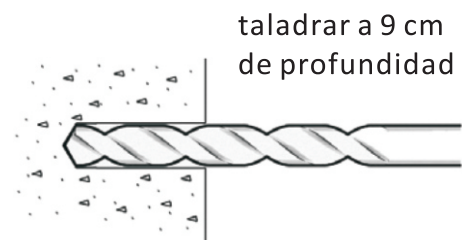

!! IMPORTANTE: Todos los orificios para tornillos deben estar alineados vertical y horizontalmente para garantizar que el toldo quede recto. Vuelva a verificar la alineación antes de perforar si no está seguro.

!! IMPORTANTE: El diámetro y la profundidad de los agujeros deben ser del mismo tamaño que los tacos.

Paso 3: Preparación para el montaje

1. Ahora que los agujeros están perforados, inserte los tacos.
2. Puede que sea necesario introducirlos con un martillo de madera (o no metálico).



Si se requiere un martillo para la instalación, recomendamos colocar la tuerca en el perno (sin apretar) antes de martillar para evitar dañar las roscas del perno.

3. Asegúrese de que los tacos estén firmemente en su lugar, pero permita que sobresalgan de la pared aproximadamente una pulgada, lo suficiente para que se pueda instalar el soporte de pared en ellos.
4. Apriete los tornillos firmemente con una llave hexagonal de 19 mm. Es preferible utilizar la llave hexagonal con el extremo cerrado en lugar de abierto para evitar dañar la tuerca si se desliza.

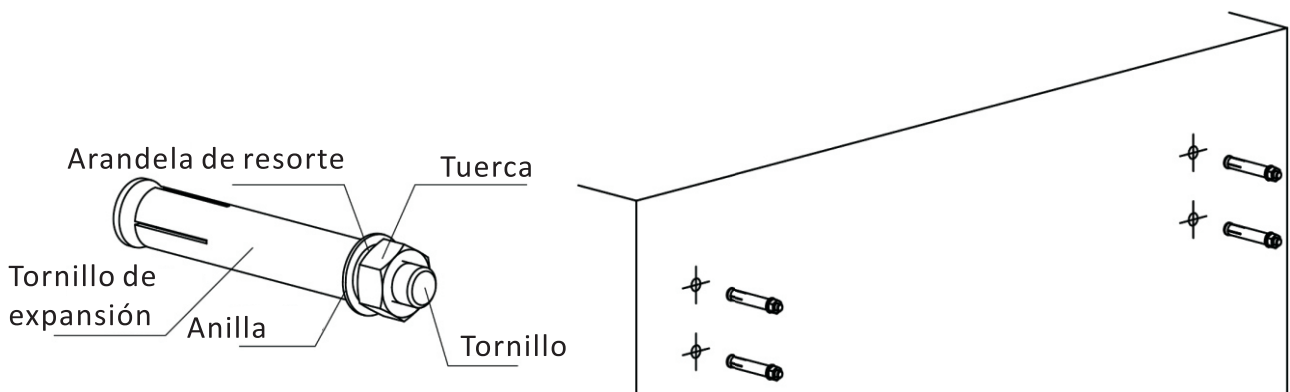

PASO 4: Montaje de los soportes de pared

1. Ahora que los tornillos están fijados a la pared, retire las tuercas que están colocadas sin apretar en los tornillos.
2. Coloque un soporte de pared sobre un juego de tornillos. Esto debería encajar si los orificios de los tornillos están alineados correctamente.
3. Cuando el soporte de pared esté asentado sobre los tornillos, coloque una arandela sobre el tornillo y luego asegúrelo con una tuerca como se muestra en el diagrama.
4. Los soportes **DEBEN** estar fijados firmemente a la pared. Si hay algún movimiento, es necesario apretarlo más.
5. Repita este paso para cada uno de los soportes de pared. Una vez que haga esto, todos los soportes de pared estarán firmemente en su lugar.

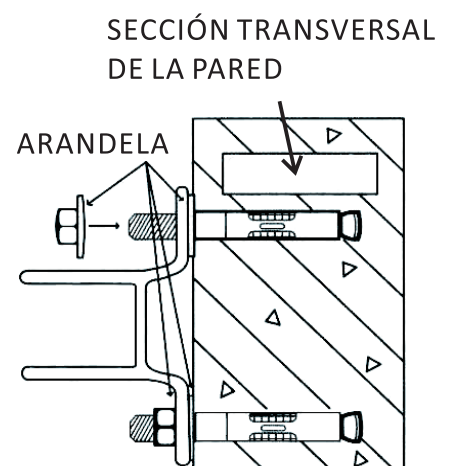

PASO 5: Montaje del toldo

1. Ahora que los soportes de pared están seguros y en su lugar, es momento de instalar el toldo en los soportes.
2. Se requieren al menos dos escaleras o sillas para instalar el toldo.
3. Coloque los tornillos de expansión originales en los soportes de pared y apriételes.
4. Finalmente, apriete todos los tornillos de expansión.
5. Usando la manivela o un motor (si corresponde), abra el toldo completamente. La barra frontal debe estar nivelada.
6. ¡Felicidades! Tu toldo está instalado. Si estás satisfecho con la altura o la barra frontal (inclinación del toldo), ¡siéntate y disfruta! Si no, sigue leyendo.

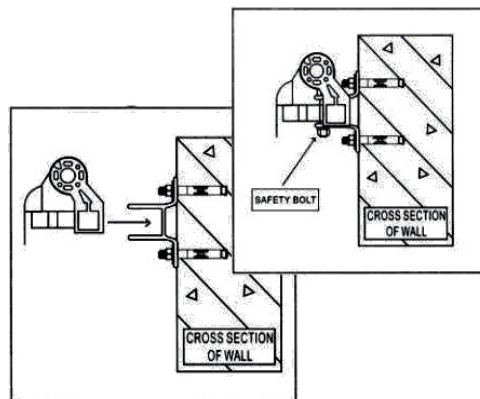

😊 INSTALACIÓN OPCIONAL

AJUSTAR LA INCLINACIÓN/ÁNGULO DEL TOLDO

Cada toldo viene con un ángulo (ángulo) predefinido que se considera ideal. Sin embargo, si es necesario un ajuste, se puede realizar en unos sencillos pasos.

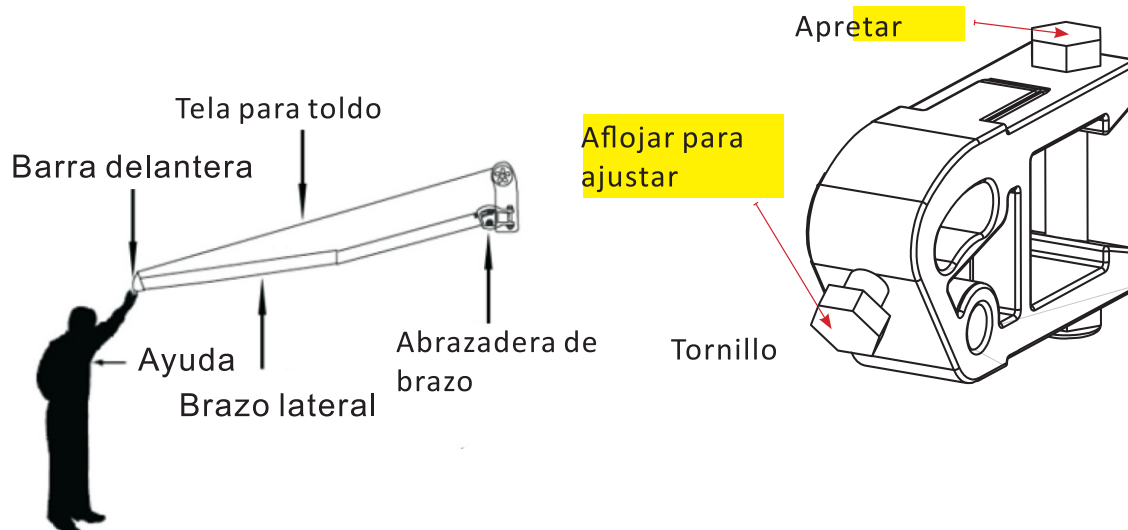

!! IMPORTANTE: Al levantar la barra frontal se reducirá el ángulo del tejido, aumentando así el riesgo de que el agua de lluvia se acumule sobre el tejido. Para evitar que el toldo se colapse debido al peso del agua de lluvia, deberá retraer el toldo cuando no esté en uso. De lo contrario, el toldo podría romperse o provocar lesiones personales.

Nota: Asegúrese de que la barra frontal esté ajustada para que esté completamente nivelada. Cualquier desalineación resultará en una retracción incorrecta.

Errores comunes

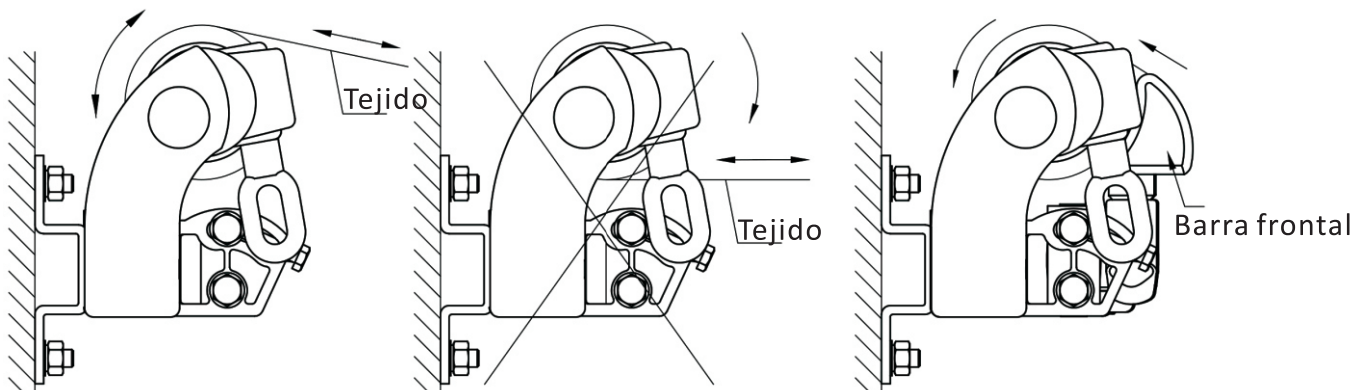

Funcionamiento correcto

Funcionamiento incorrecto

ADVERTENCIA: Cuando la barra frontal toque el rodillo, como se muestra en la figura, no intente acercarlas, de lo contrario el producto podría dañarse.