

Installation & Assembly

Version:1.0

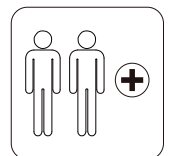

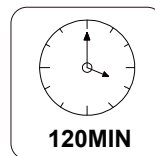

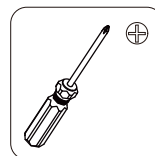
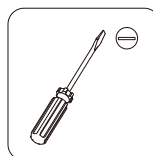
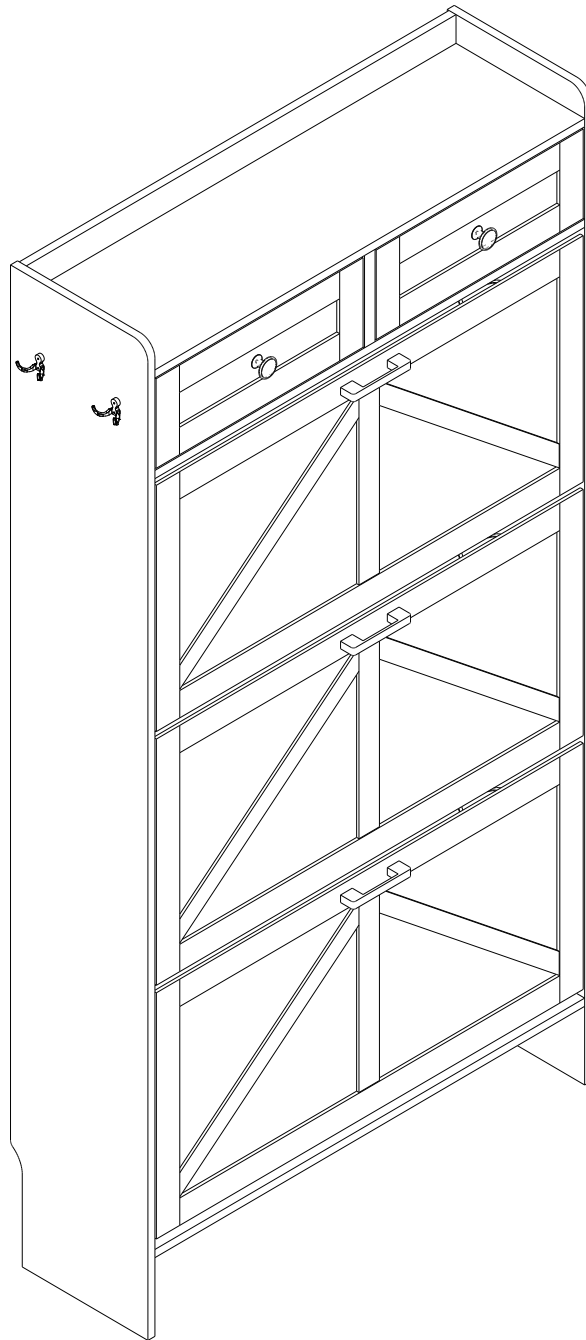
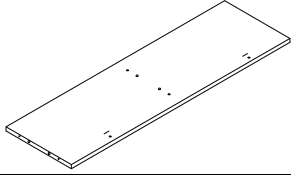
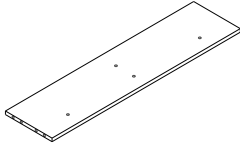
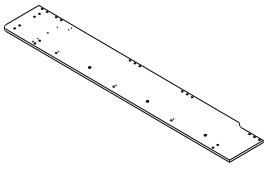
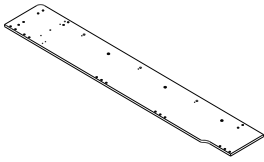
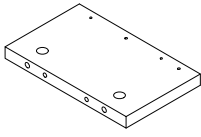
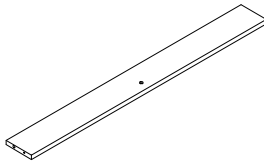
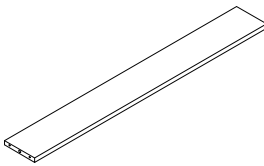
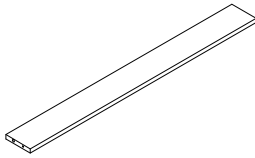
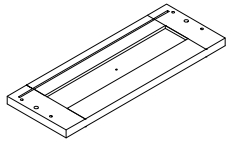
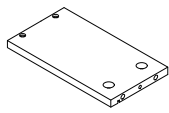

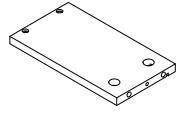
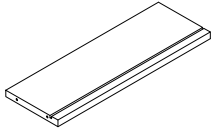
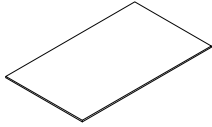
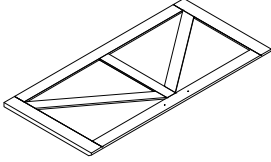
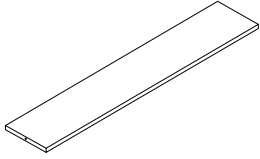
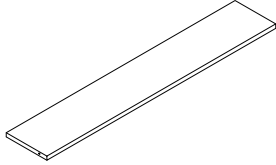

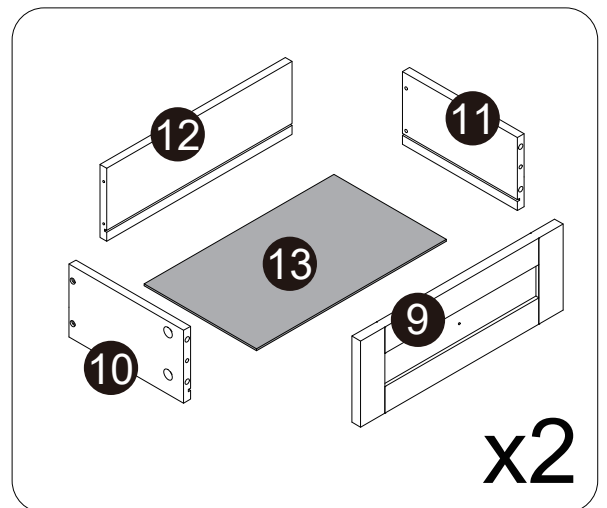
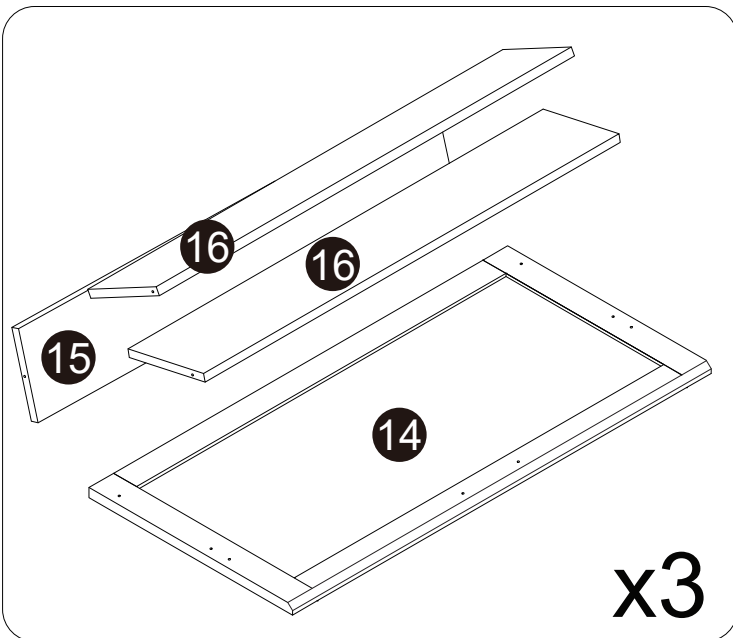
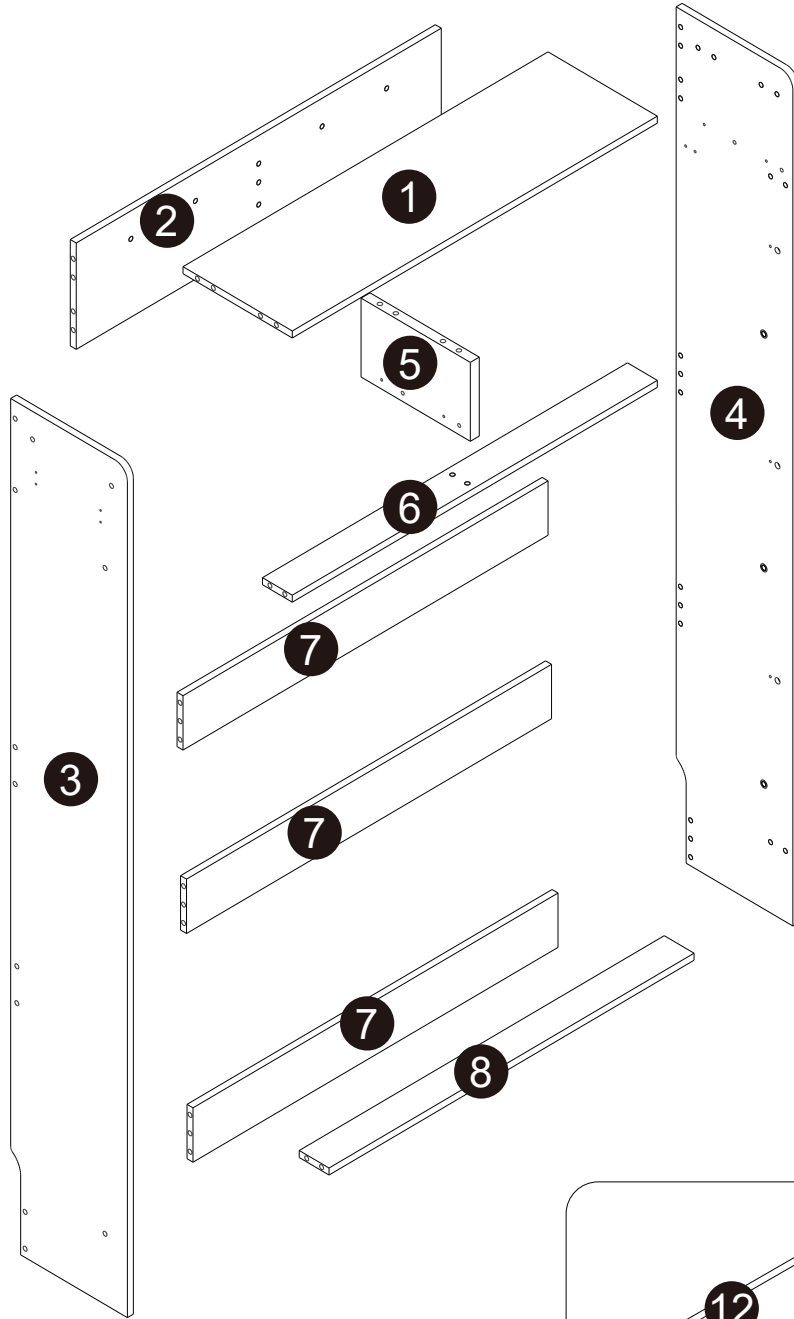

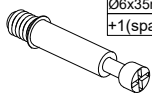

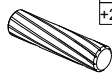
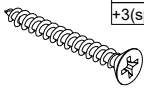



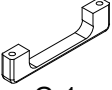

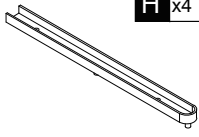

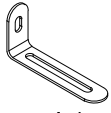

EN_IMPORTANT, RETAIN FOR FUTURE REFERENCE: READ CAREFULLY.

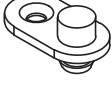
NO.	PARTS	QTY	SPARE
①		x1	
②		x1	
③		x1	
④		x1	
⑤		x1	
⑥		x1	
⑦		x3	
⑧		x1	
⑨		x2	
⑩		x2	

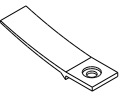
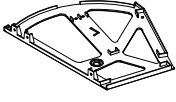
NO.	PARTS	QTY	SPARE
⑪		x2	
⑫		x2	
⑬		x2	
⑭		x3	
⑮		x3	
⑯		x6	

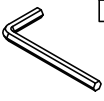

<p>A x10 Ø6x35mm +1(spare)</p> 	<p>B x10 Ø15x10mm +1(spare)</p> 	<p>C x29 Ø6x30mm +2(spare)</p> 	<p>D x37 Ø4x35mm +3(spare)</p> 	<p>E x44 Ø3.5x12mm +2(spare)</p> 	<p>F x2</p>   <p>F-1 F-2</p>	
<p>G x3</p>   <p>G-1 G-2</p>	<p>H x4</p> 	<p>I x8 Ø3x12mm +1(spare)</p> 	<p>J x2 Ø4x12mm</p>   <p>J-1 J-2</p>	<p>K x2</p>   <p>K-1 K-2</p>	<p>M x28 +4(spare)</p> 	
<p>N-1 +1(spare)</p> 	<p>N-2 +1(spare)</p> 	<p>N x6 N-3</p> 	<p>O x2</p> 	<p>L x3</p> 	<p>R x3</p> 	<p>P x2</p>   <p>P-1 P-2</p>
<p>Q x1 M5</p> 						

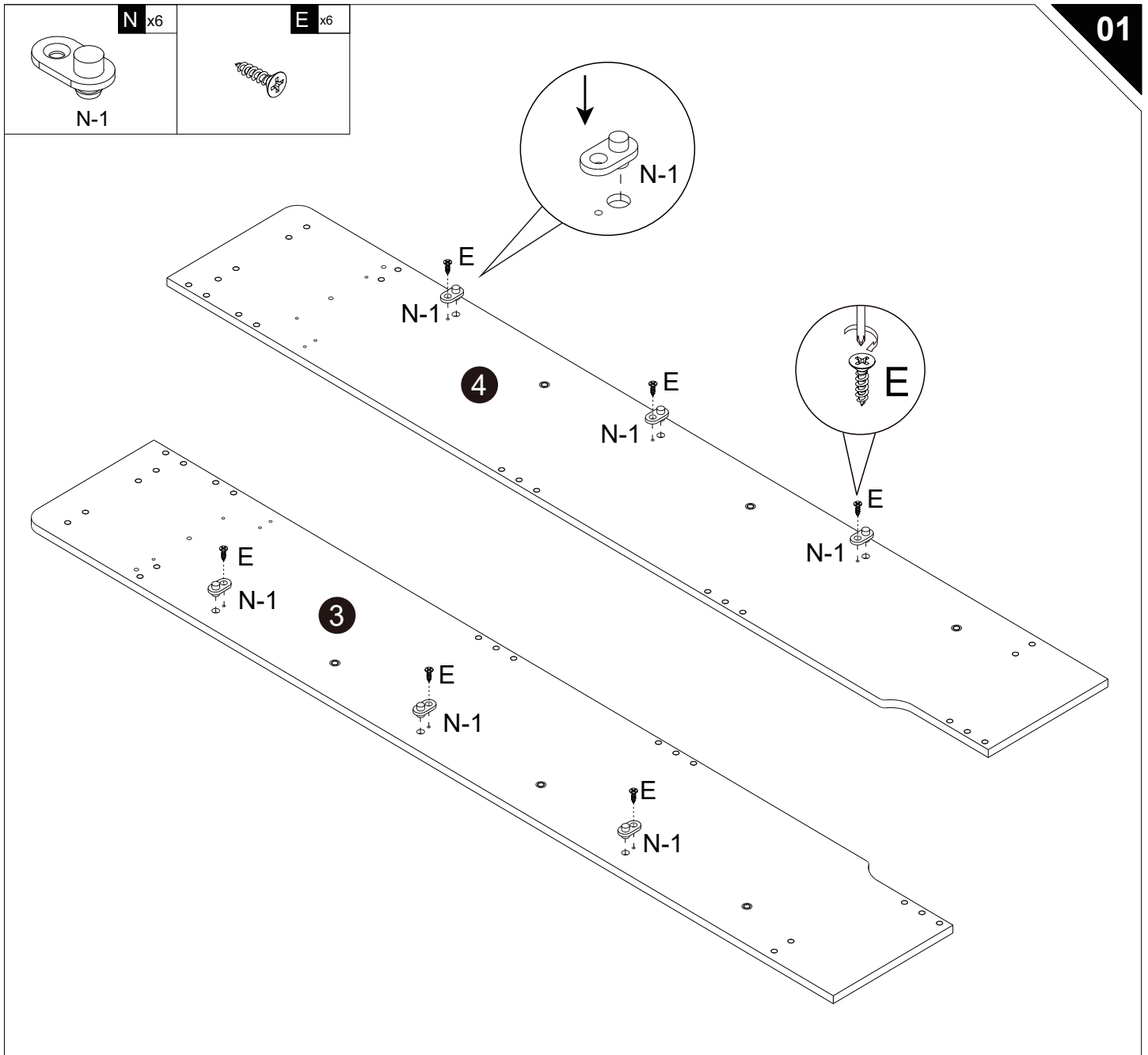

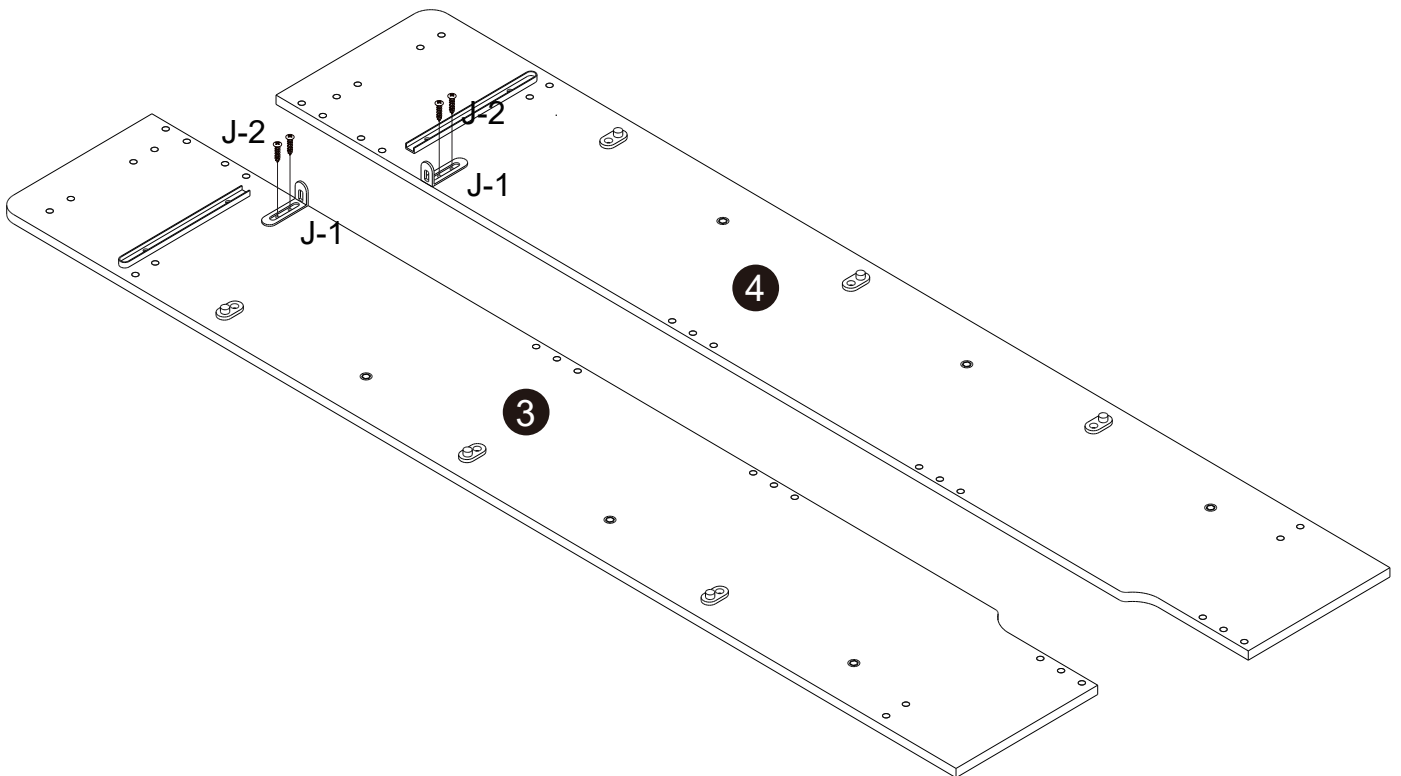
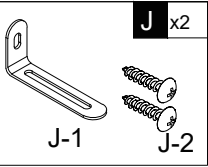
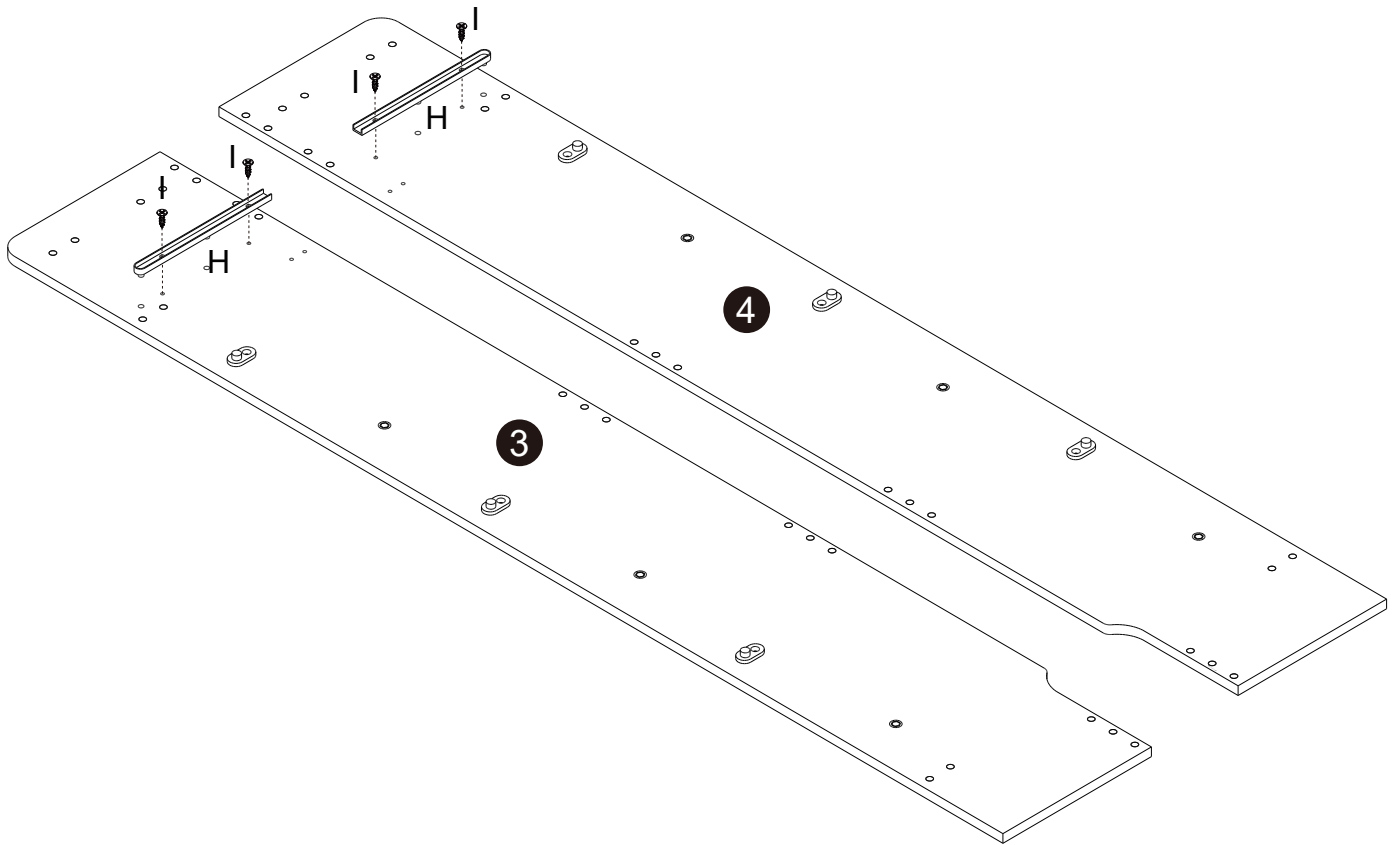
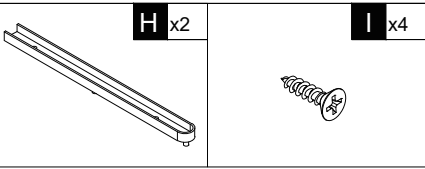

H x2

I x4

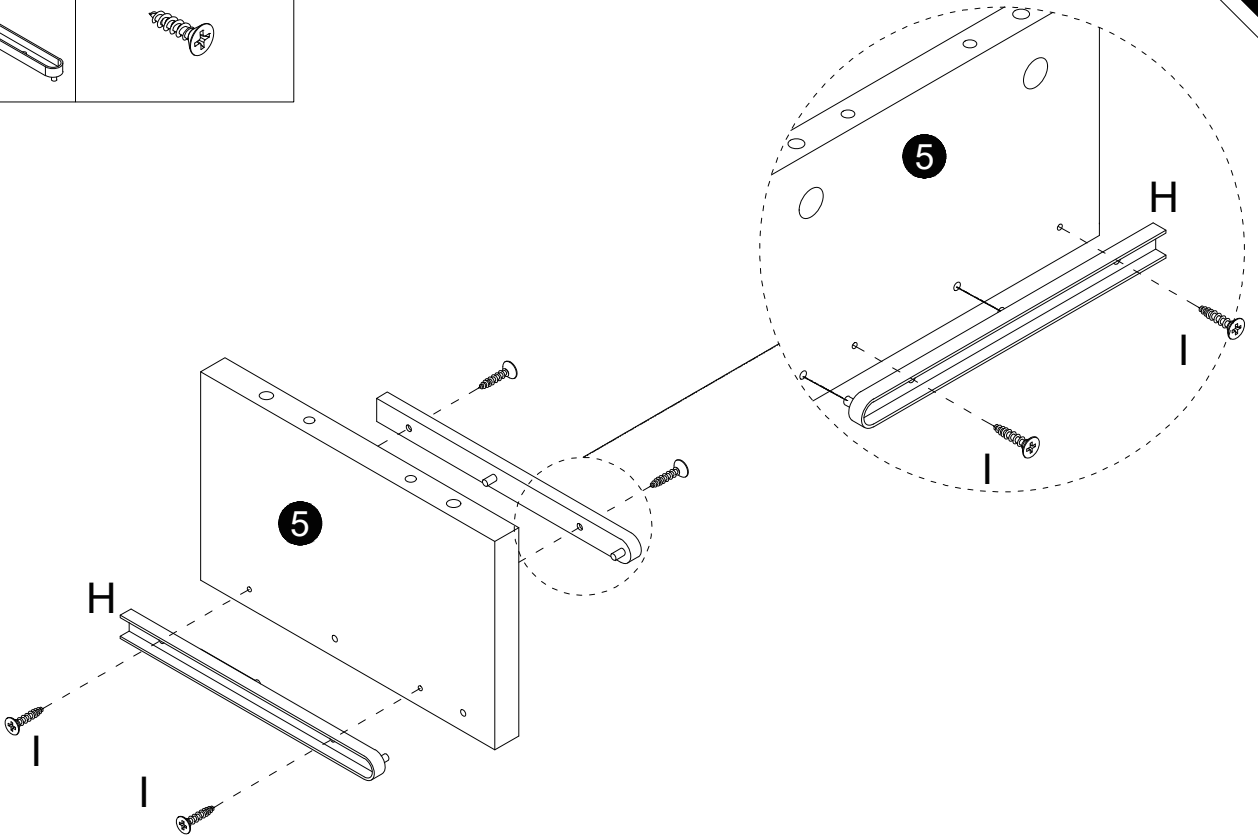
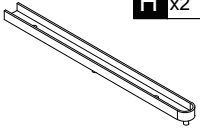

C x1

D x1

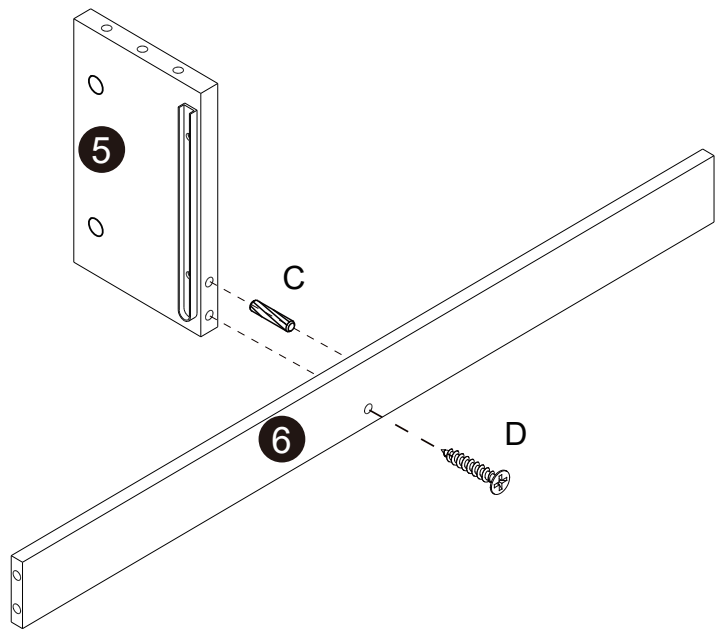
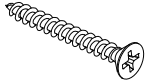

A x2

O x2

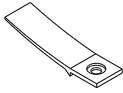
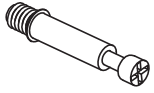

E x2

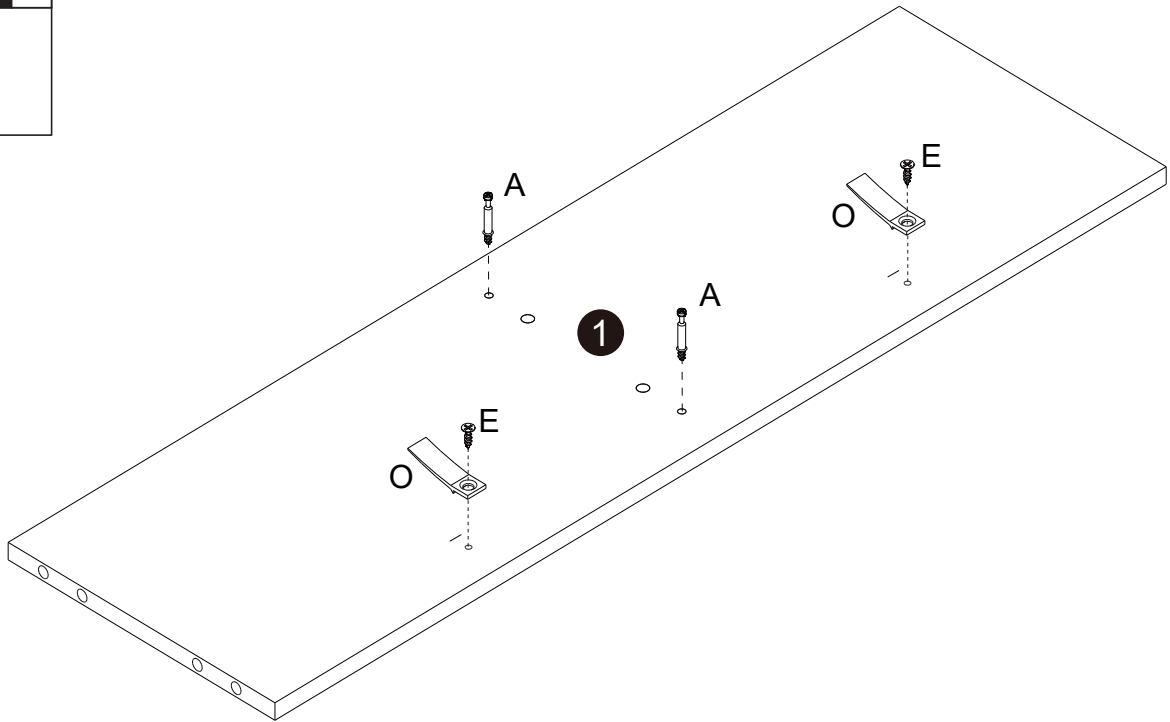

B x2

C x2

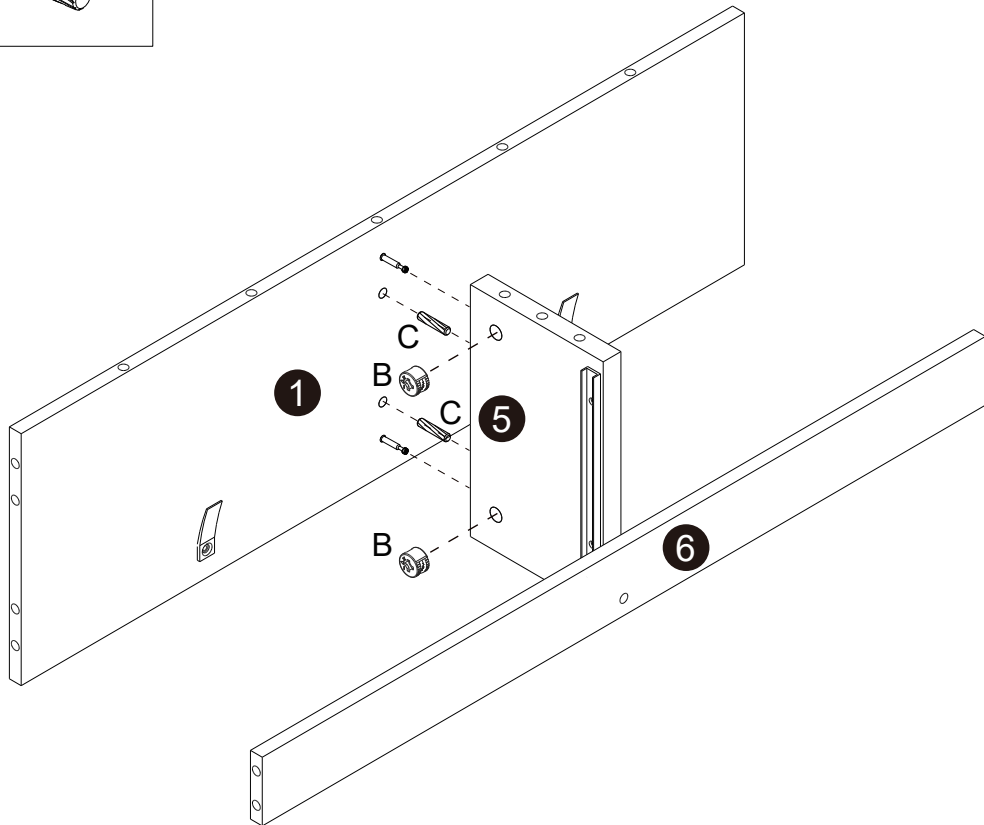

C x4

D x4

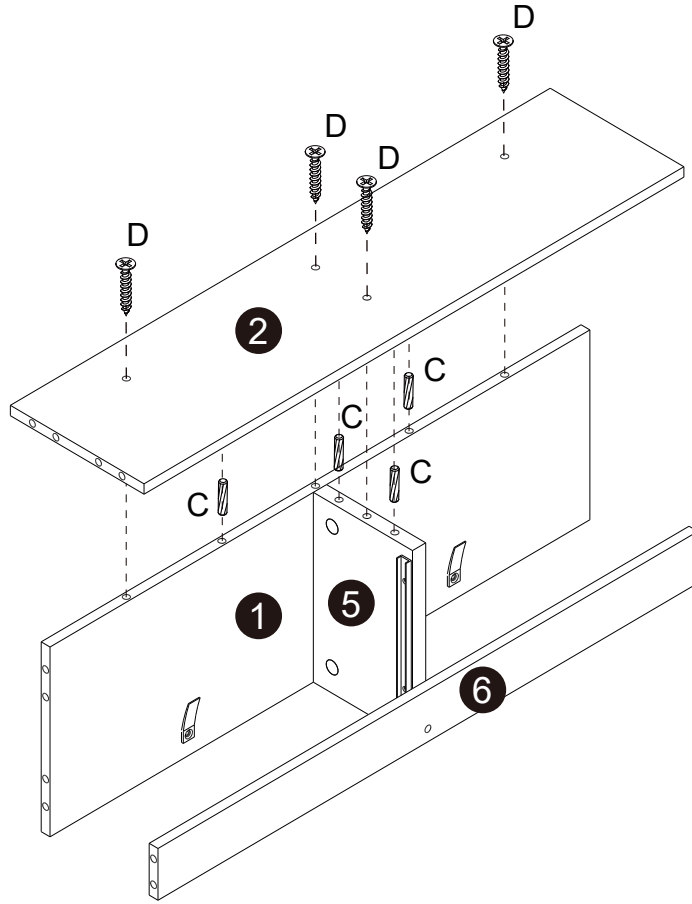
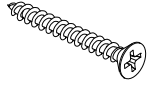
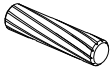

C x6

D x6

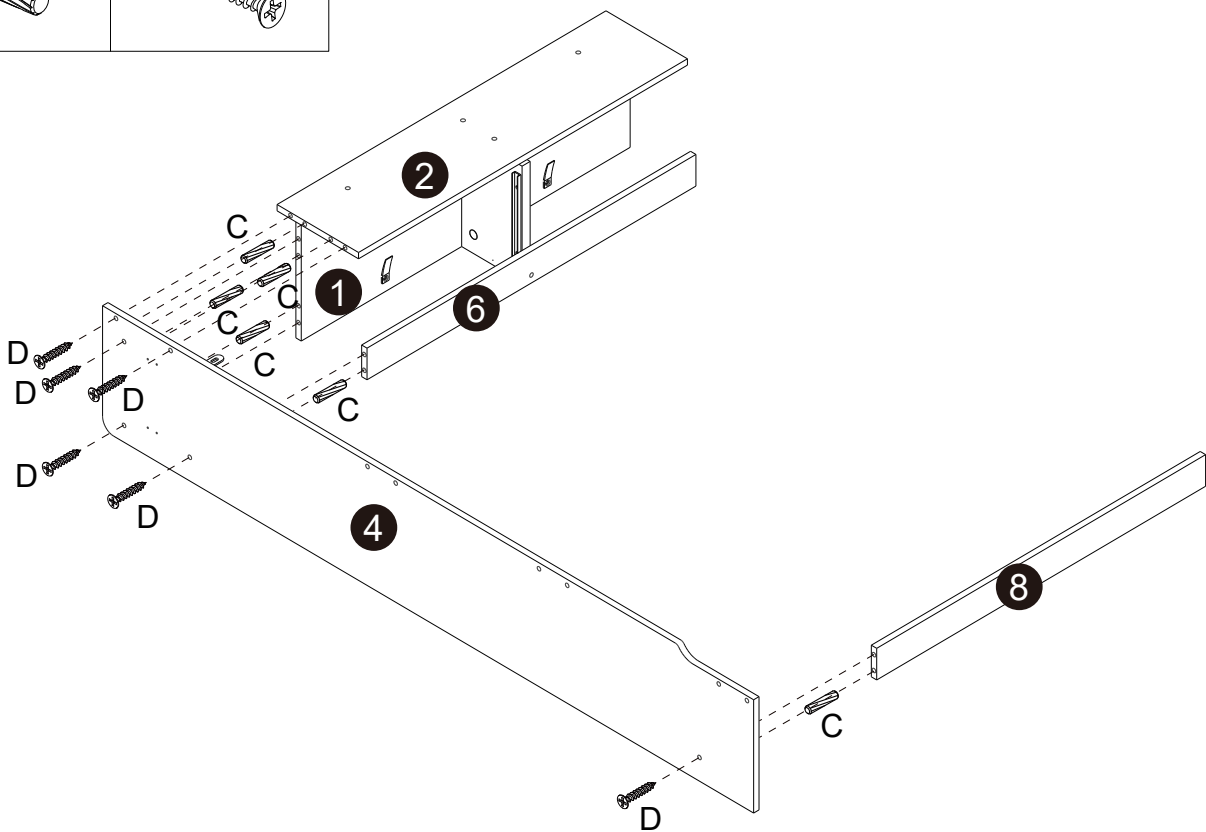
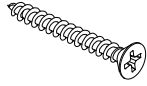
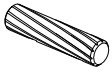

C x3

D x6

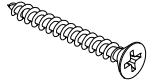
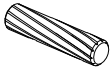

During the installation process, you need to keep your balance by hand to avoid damage.

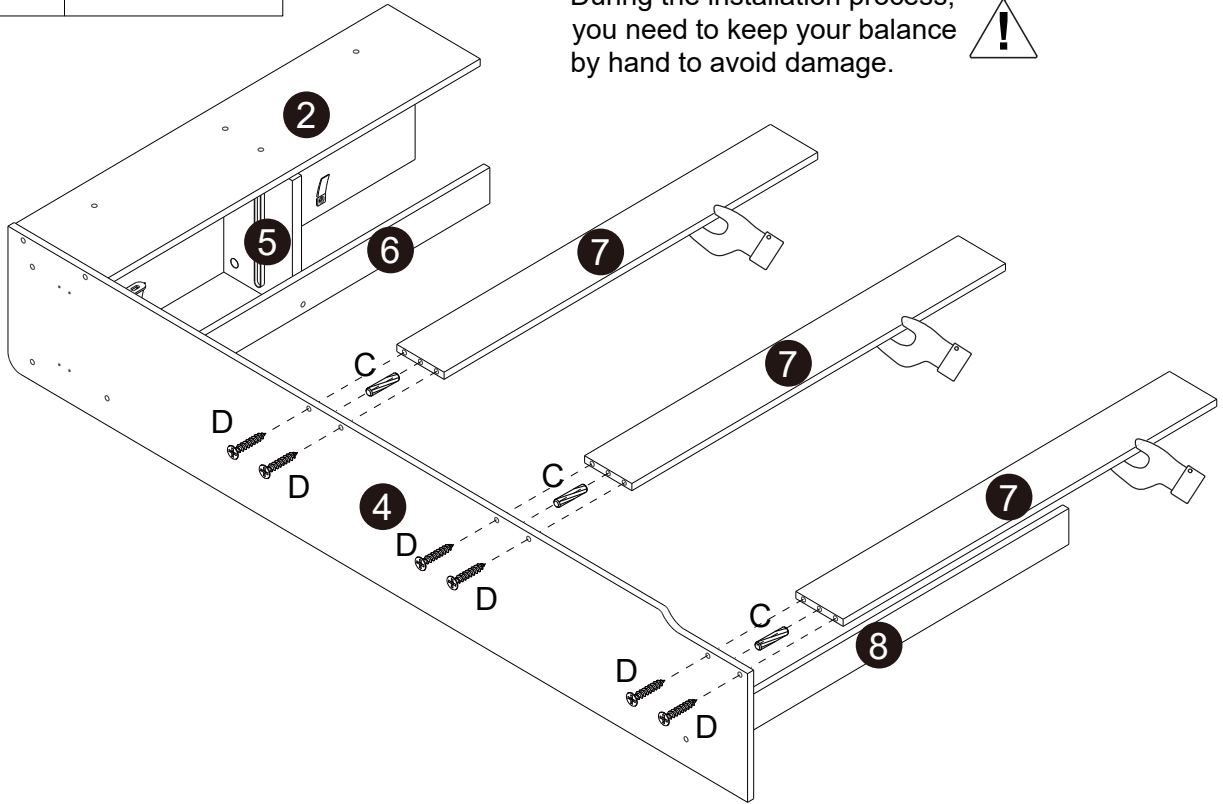

C x9

D x12

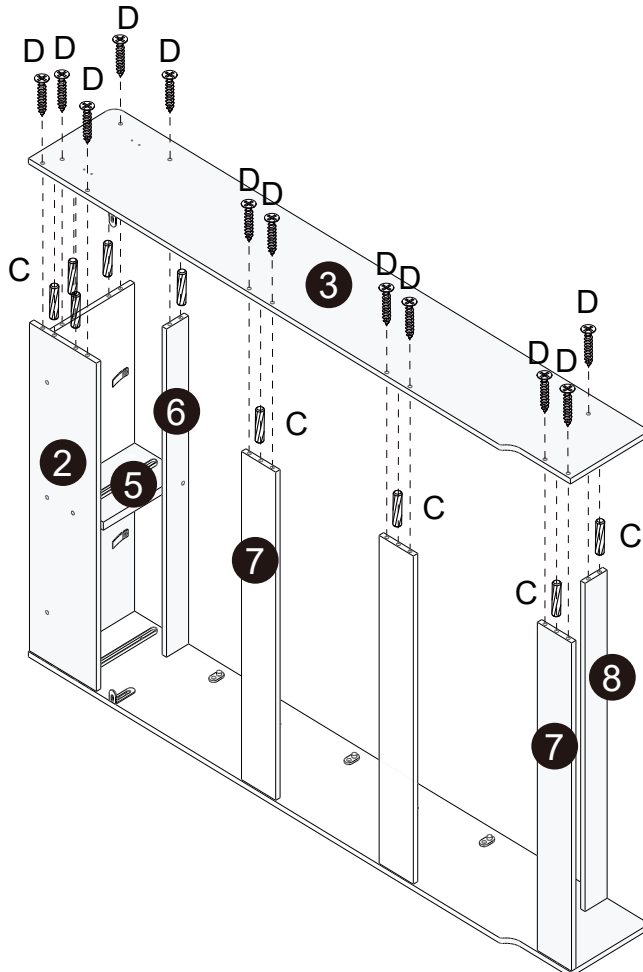
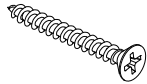

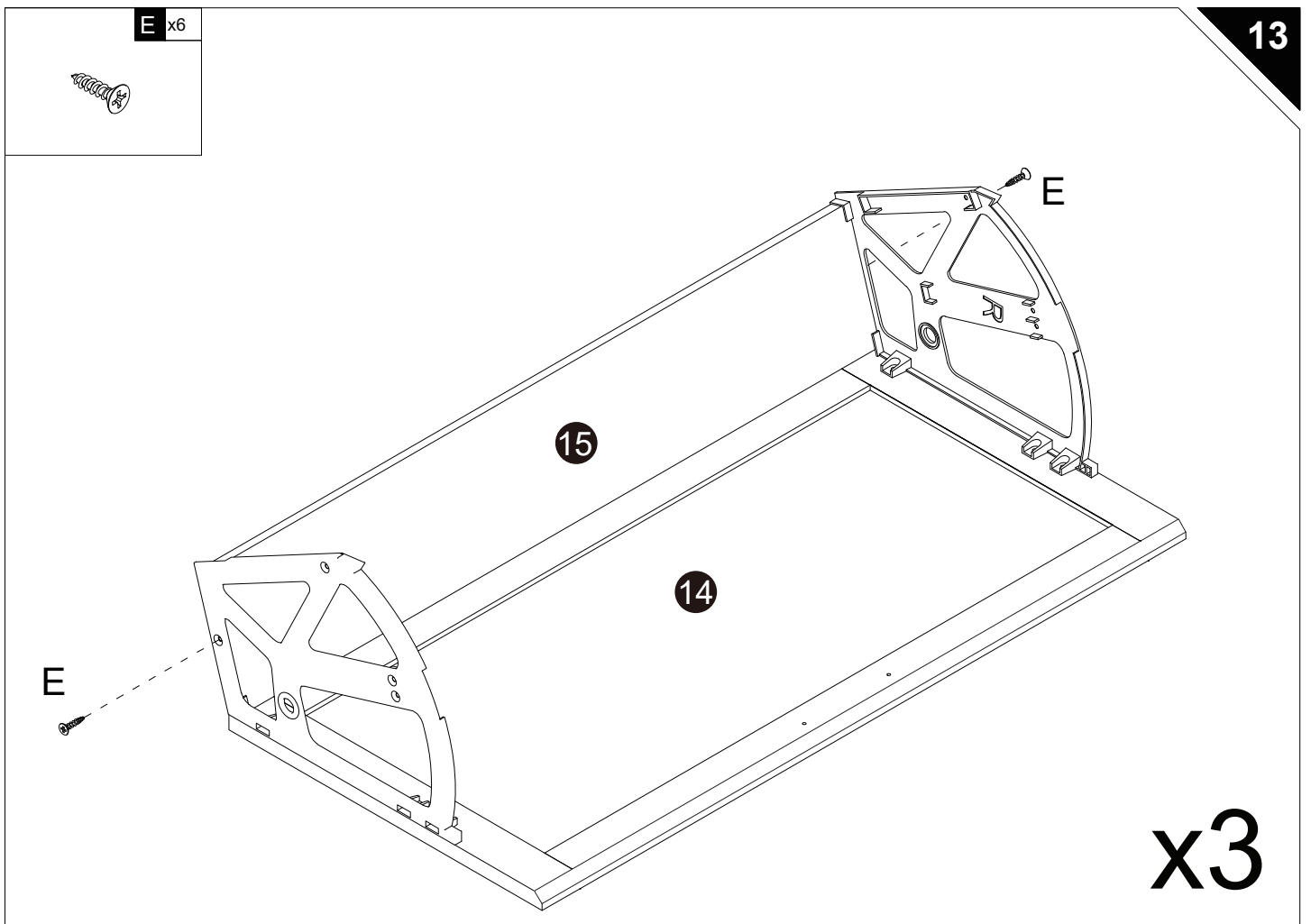
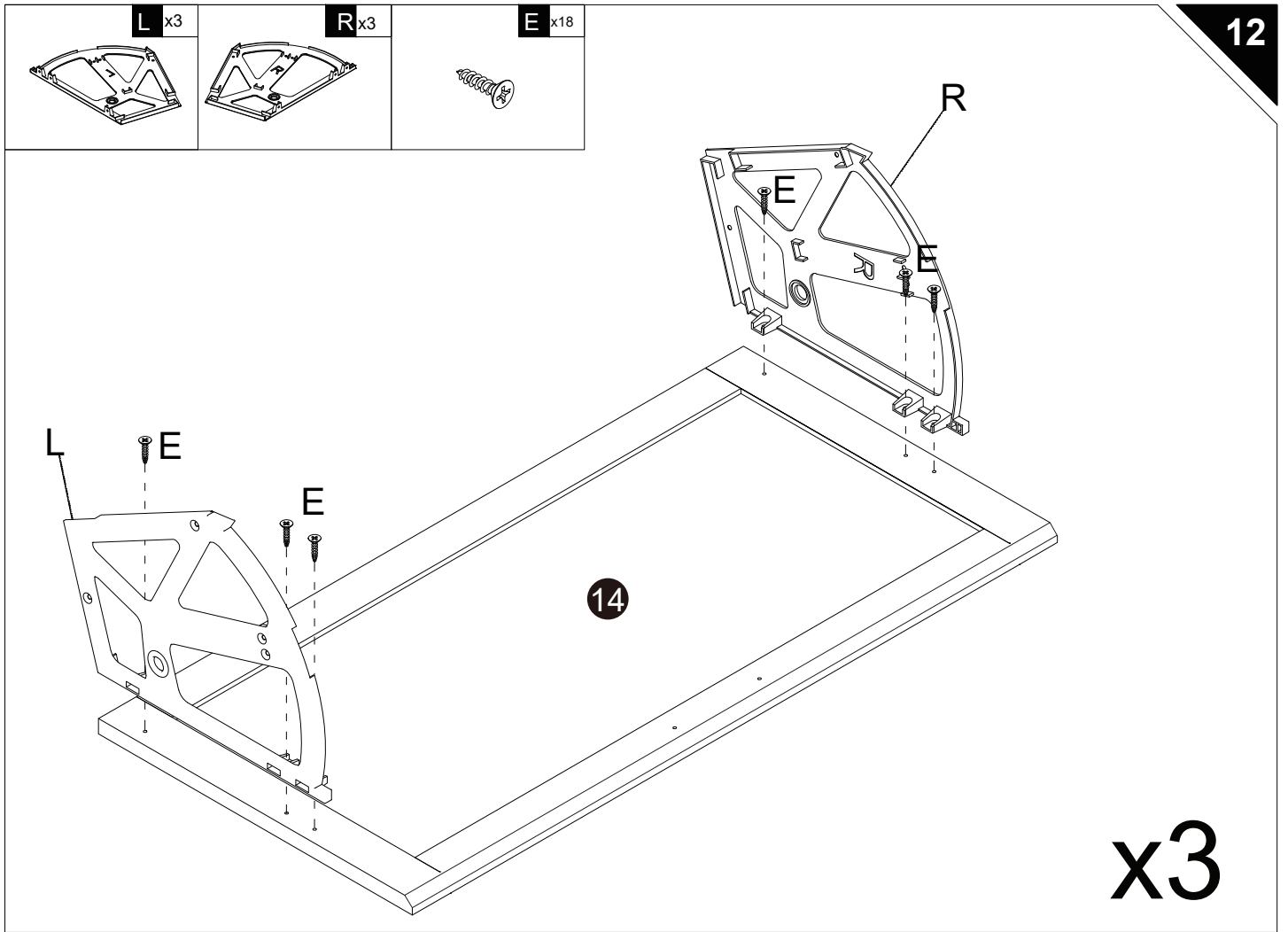

14

E x6

G x3

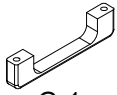

G-1

G-2

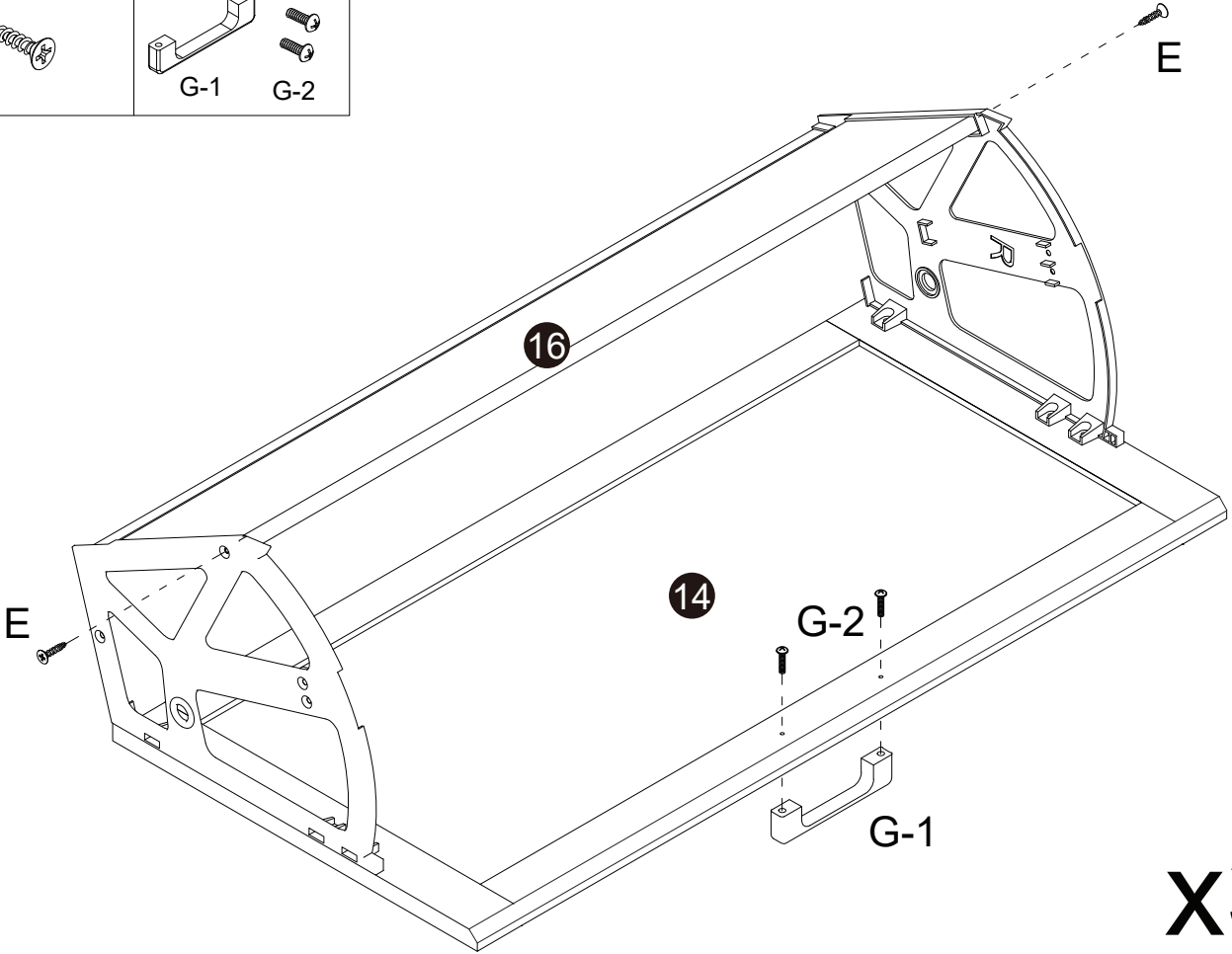

x3

15

A x8

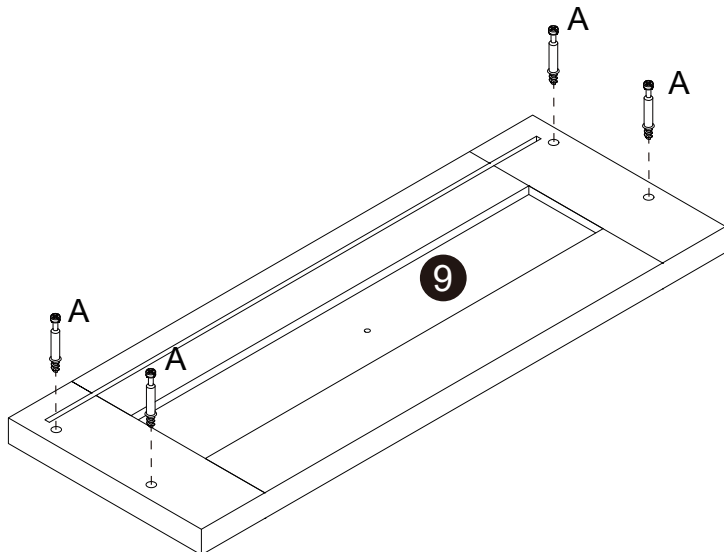
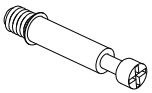

x2

D x8

16

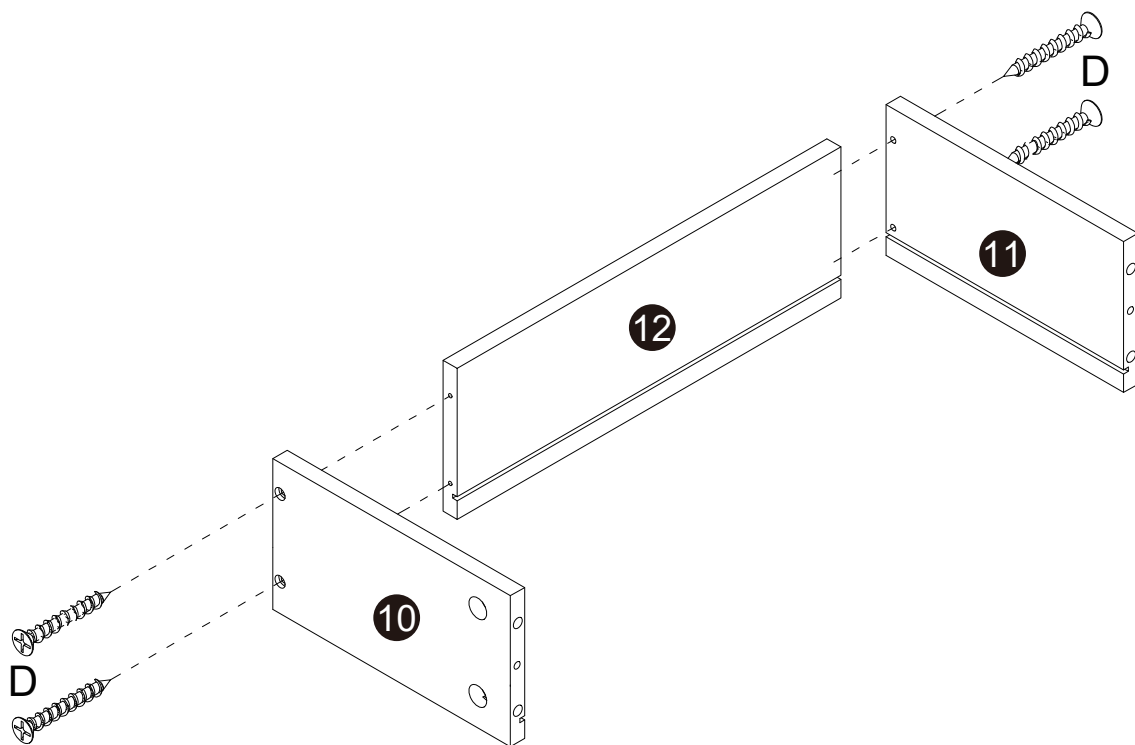
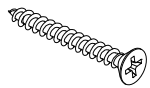

x2

17

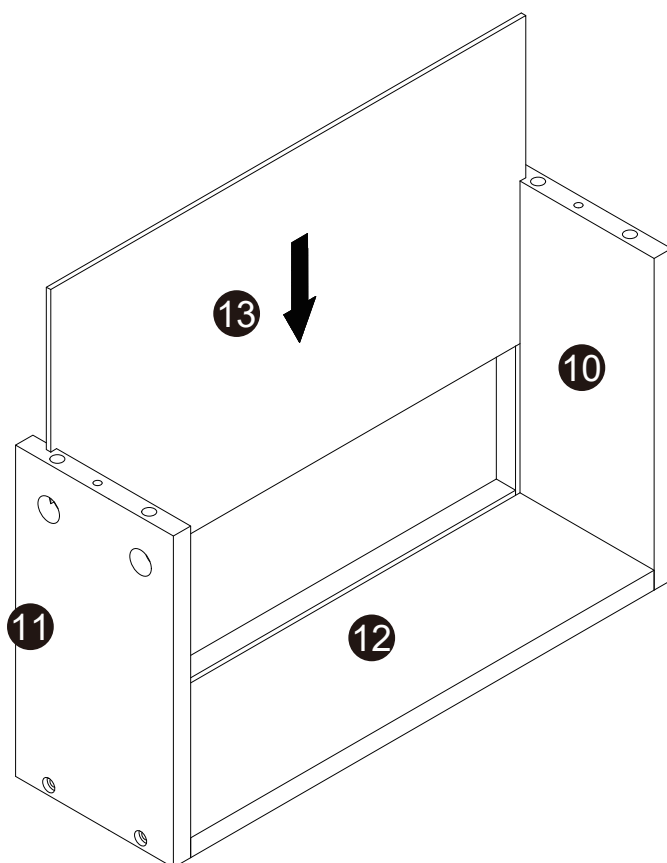

x2

B x8

C x4

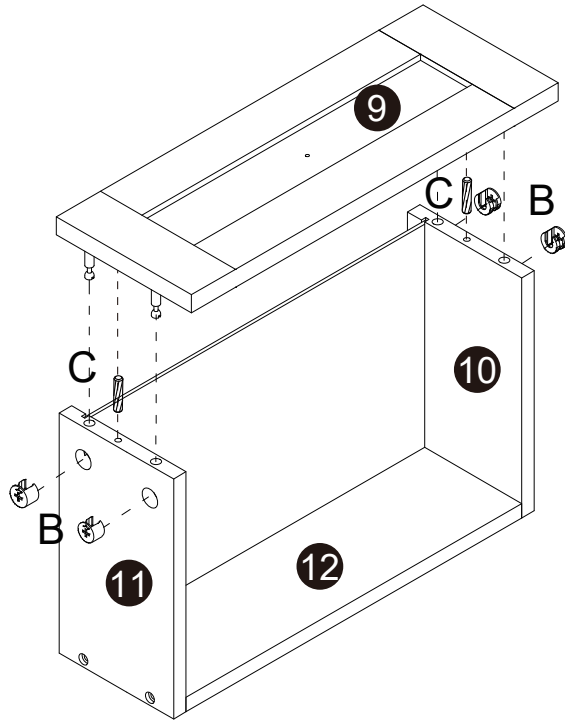
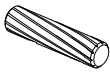

x2

F x2



F-1

F-2

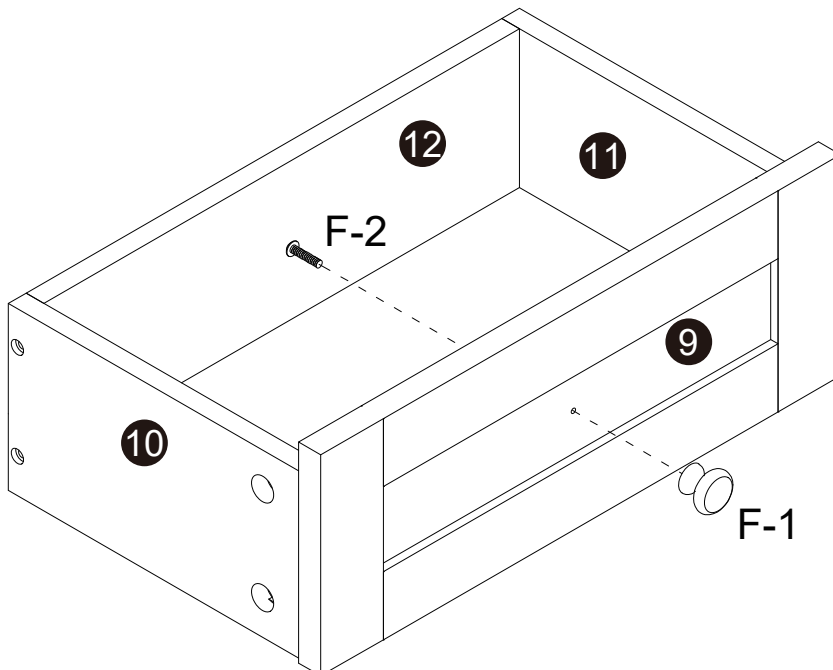

x2

K x2

M x24

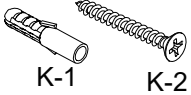

K-1

K-2

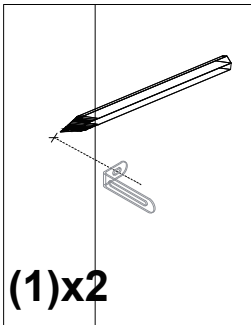

(1)x2

then, use a ruler to measure the approximate height of the product on the wall, and then mark it with a pen.

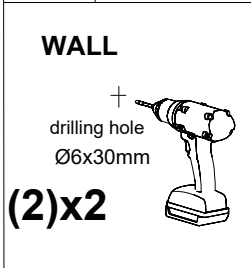

WALL

+
drilling hole
Ø6x30mm

(2)x2

Then use a tape drill to make holes in the wall that are suitable for the product screws.

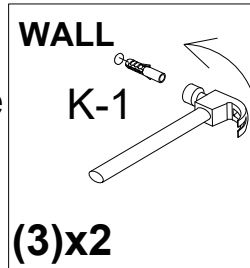

WALL

K-1

(3)x2

Then, put the expansion bolt into the hole

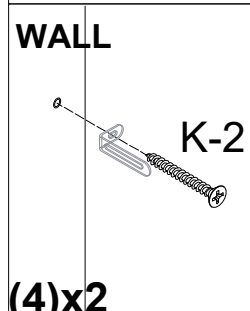

WALL

K-2

(4)x2

Finally, pass the matching screws through the "anti-rewind" and tighten them to fix them on the wall.

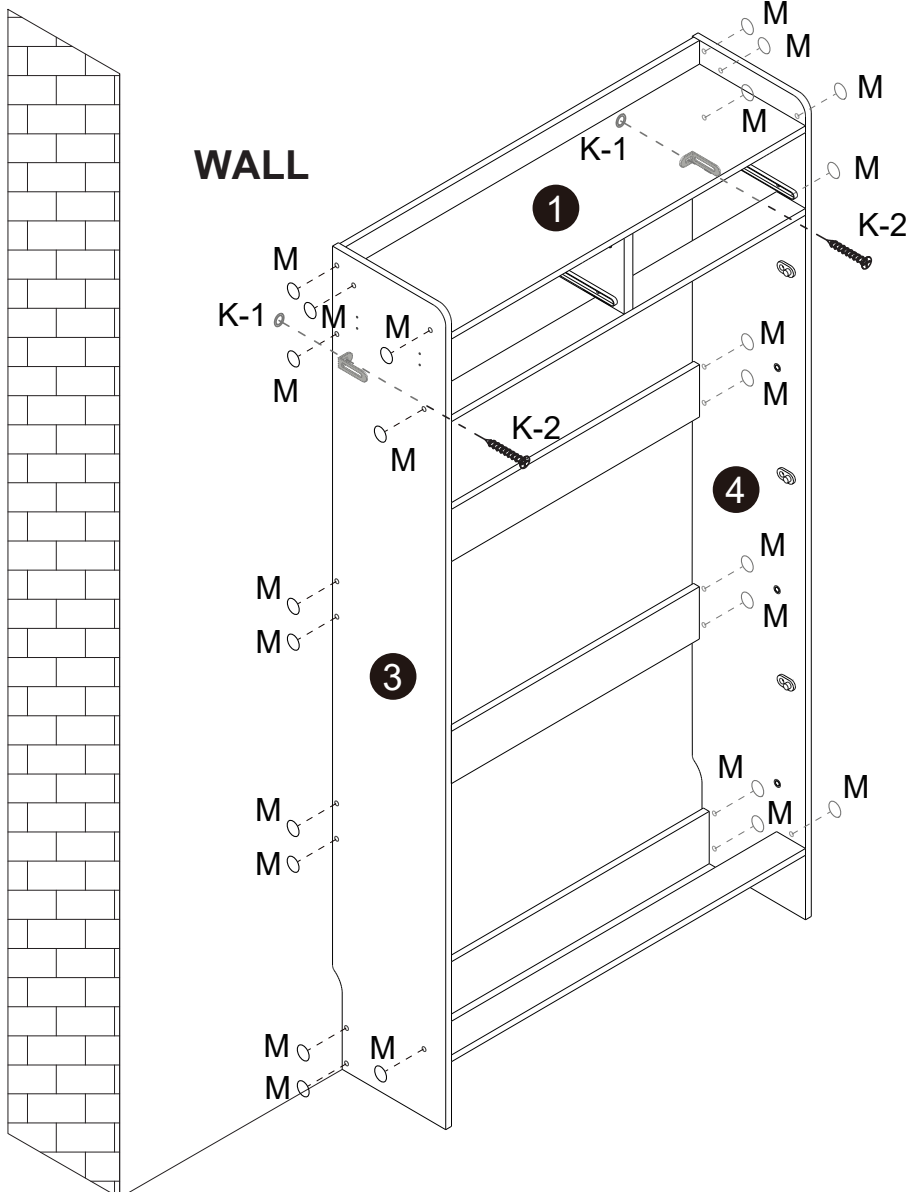



N-2



N-3

N x6

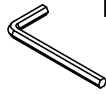

Q x1

If the installation cannot be placed in the correct position, please try operating at other inclined angles.

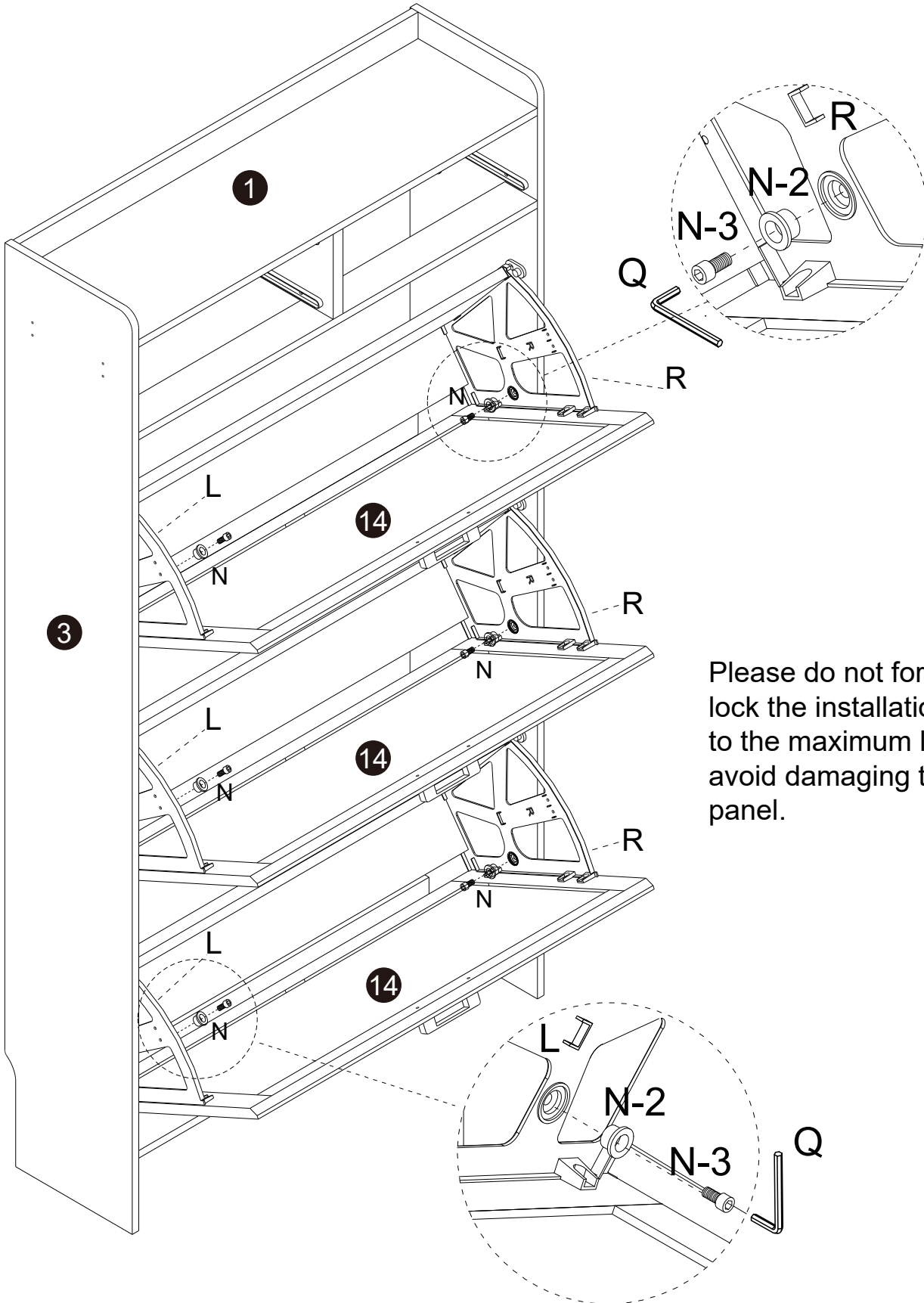

Please do not forcefully lock the installation screws to the maximum limit to avoid damaging the side panel.

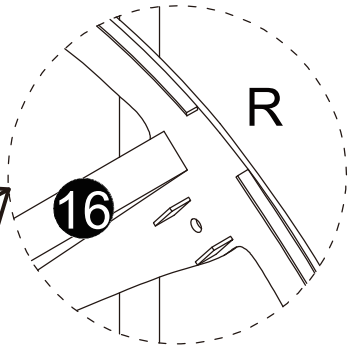
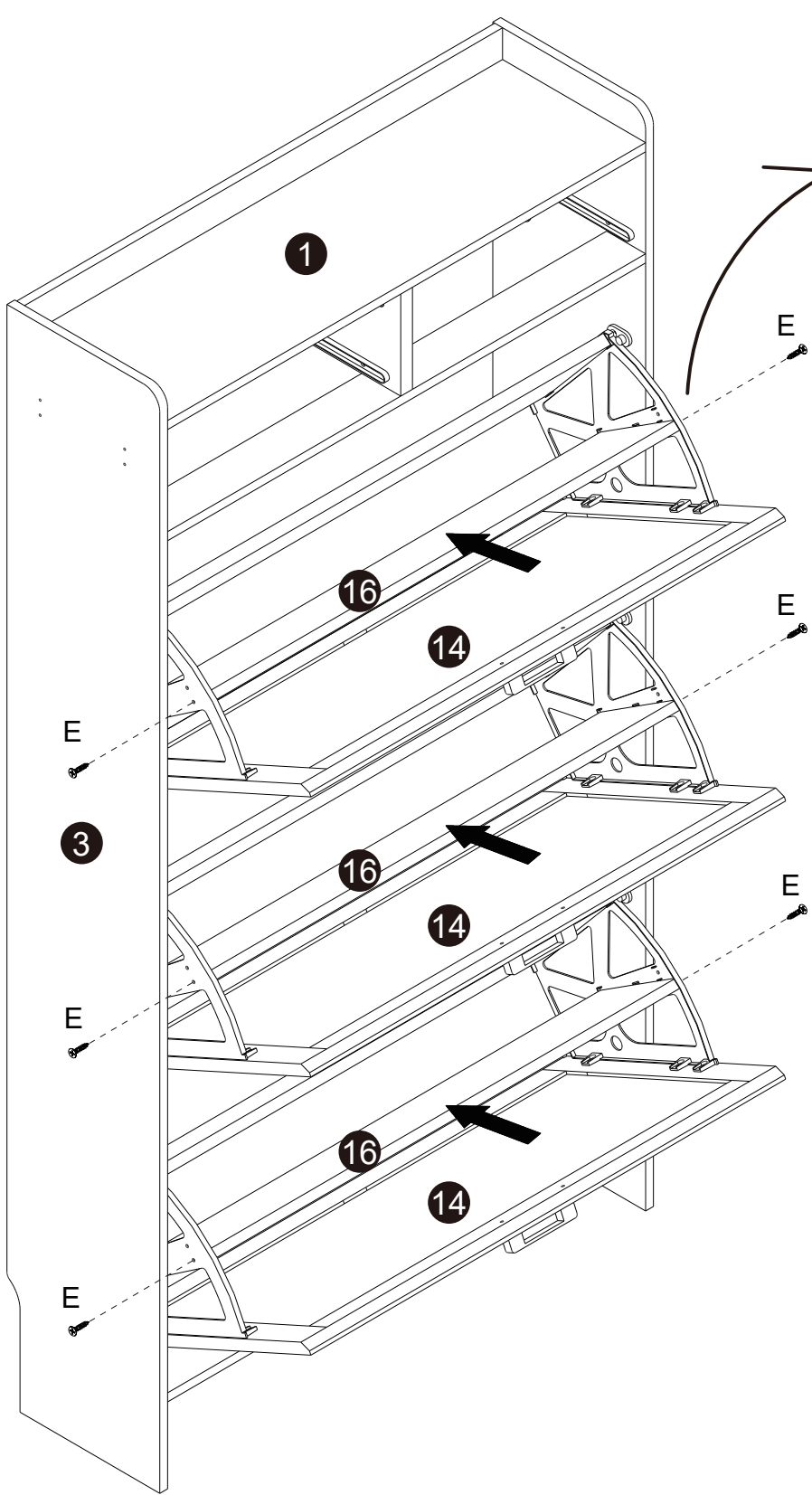

OR

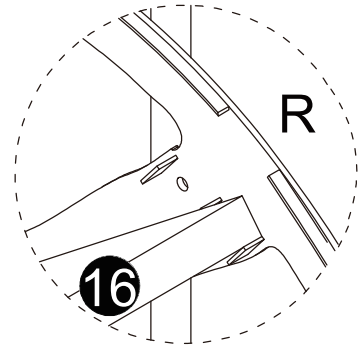

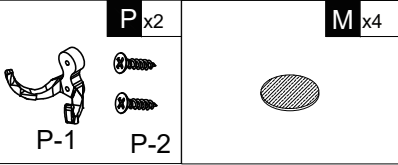

The P number can be mounted to the No. 3 or No. 4 side panels

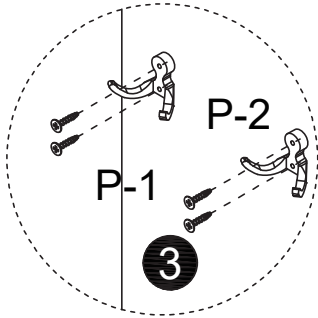

OR

