

Owner Manual

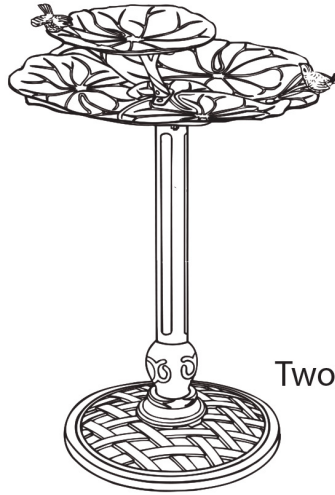

Two Tier Lily Pad Birdbath

Parts list

Part #	Description	Quantity	Part #	Description	Quantity
A	Large Birdbath Bowl	1	AA	Short Hex Head Bolt	3
B	Small Birdbath Bowl	1	BB	Slotted Set Screw	3
C	Stem	1	CC	Screw	2
D	Center Post	1	DD	Washer	8
E	Base	1	EE	Nut	3
F	Bird	2	FF	Flat Head Screw	2
			GG	Long Hex Head Screw	2
			HH	Lock Washer	8

FRIENDLY REMINDERS

- * Heavy! Handle with care. Please keep children away from assembly area.
- * During assembly, place the empty carton beneath the casting parts to protect the finish from damage.
- * Do not over-tighten. Aluminum is a soft metal, insert bolts carefully and don't over-tighten.

Step 1

Turn the Birdbath Bowl (A) upside down on a soft surface. Attach the Center Post (D) to the Birdbath Bowl (A) by using three short hex head bolts (AA), three lock washers (HH), and three washers (DD)

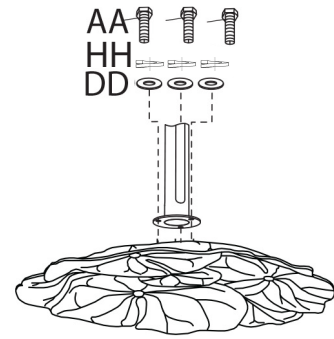

Step 2

With the birdbath upside down, attach the base (E) onto the center post (D) using three slotted set screws (BB), three lock washers (HH), three washers (DD), and three nuts (EE).

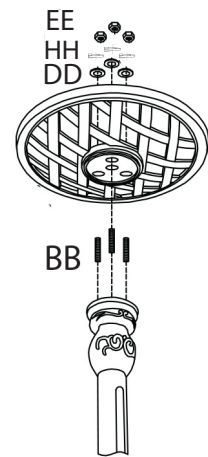

Step 3

Turn the whole birdbath right side up. Screw the Bird (F) on the Birdbath Bowl (A) using one screw (CC).

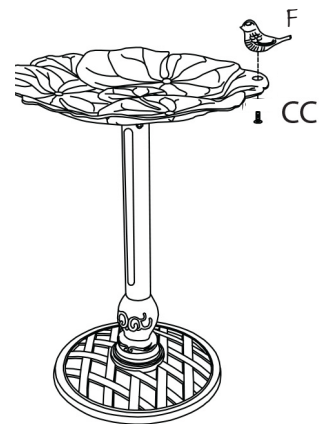

Step 4

Attach the Stem (C) onto the center of the Large Birdbath Bowl (A) using 2 Flat Head Screws (FF)

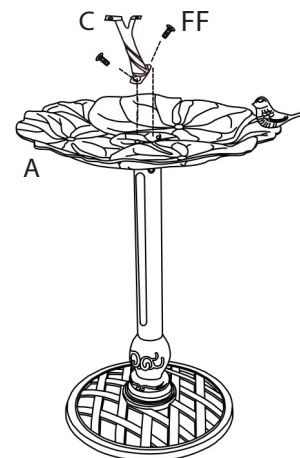

Step 5

Attach another Bird (F) on the Small Birdbath Bowl (B), using one screw (CC)

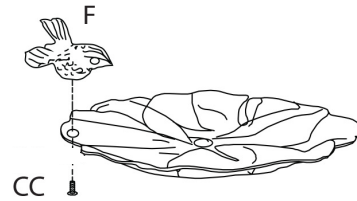

Step 6

Screw the Small Birdbath Bowl (B) on the Stem (C) from the bottom using two long hex head screws (GG), two lock washers (HH), two wash (DD).

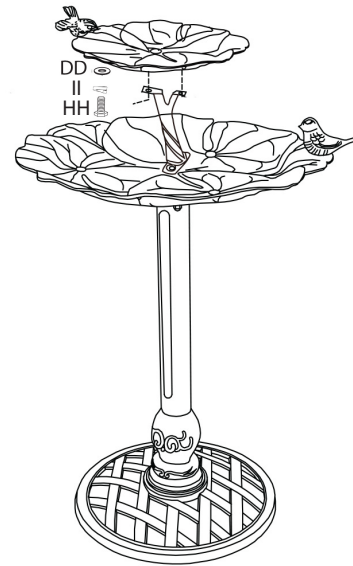

Special Notes

This bird bath is made with an old world, traditional hand-crafted look. Because of the nature of cast iron or aluminum, you may find roughness on the surface of the design. Slight pinholes are also present in the metal casting that is customary to hand-crafted original iron work. These irregularities enhance the individuality of the piece. They should not be considered defects.

Care and Maintenance

1. Should the finish get scratched down to metal surface, cover the scratched area with enamel paint as soon as possible to keep the best condition.
2. Cleaning- Use mild soap and water. Do not use harsh abrasive material, cleaners, or bleach products. Rinse with clean water and dry thoroughly with rags or direct sunlight.
3. Periodically check and tighten all bolts.