

WARRANTY INFORMATION

- Do not expose the surfaces to direct sunlight or to extreme environmental conditions.
- Clean the surfaces preferable with a clean damp cloth, then dry with a clean towel.
- Do not use solvents or abrasive materials to clean the unit. If you decide to use a cleaning agent, test first on an area hidden from view.
- Do not use solvents or abrasive materials to clean the unit. If you decide to use a cleaning agent, test first on an area hidden from view.
- Replacement parts might be available to you at no charge, with an original proof of purchase and where a defect has arisen, wholly or substantially, as a result of faulty manufacturing, parts or workmanship during the Warranty Period.
- The warranty does not extend to regular wear and tear, nor the manufacturer assumes liability for damages or consequences due to accidents, incorrect assembly, negligence, improper use, modifications, or not heeding the above warnings.

Thank you so much for your support! We hope you enjoy your purchase. If there is any damage or missing accessories, please feel free to contact us for free replacement or refund.

Thank you!

TABLE OF CONTENTS

01 Warranty Information

02 Important Safety Instructions

02 Tools Needed

03 Parts List

04 Assembly

IMPORTANT SAFETY INSTRUCTIONS

- Check if all the parts are complete before installation.
- Read through the instructions before installing the cabinet.
- Keep the small parts away from children to avoid the risk of swallowing.

TOOLS NEEDED

Screws Driver -1PC



(Not included)

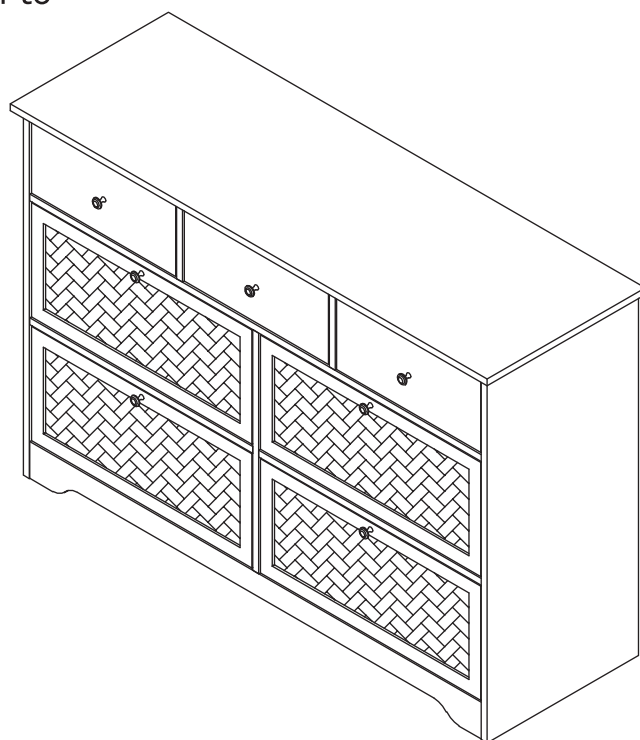

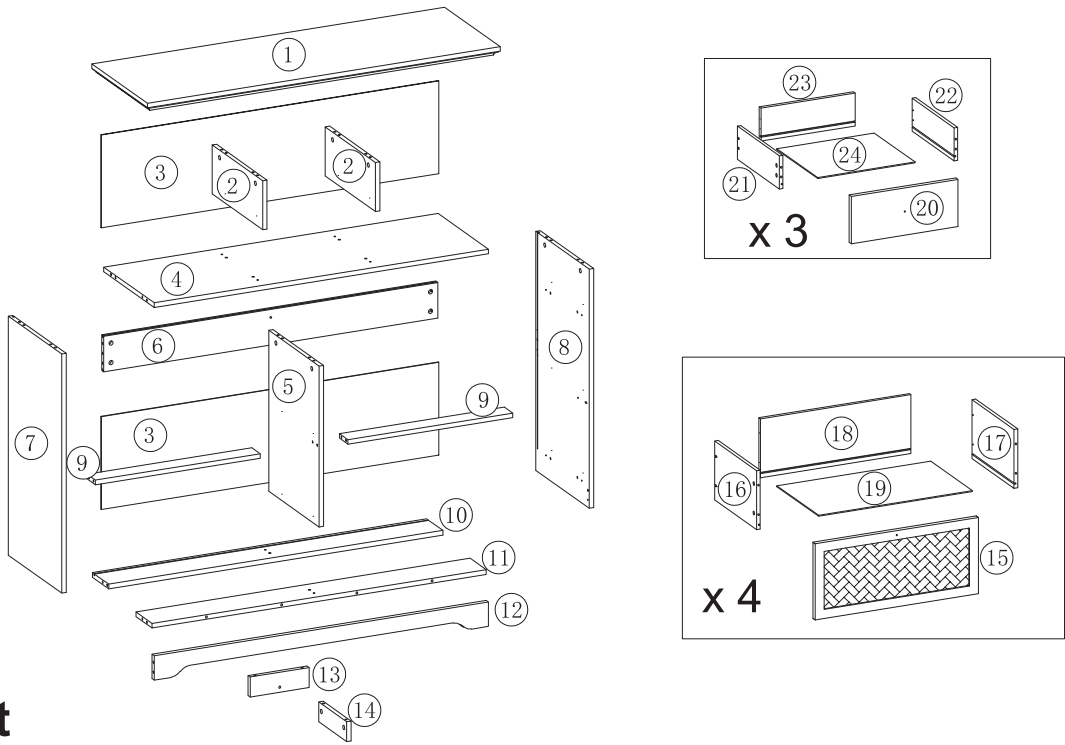



Parts List

1 x 1	2 x 2	3 x 2	4 x 1	5 x 1
6 x 1	7 x 1	8 x 1	9 x 2	10 x 1
11 x 1	12 x 1	13 x 1	14 x 1	15 x 4
16 x 4	17 x 4	18 x 4	19 x 4	20 x 3
21 x 3	22 x 3	23 x 3	24 x 3	

A x 62	B x 62	C x 32	D x 38	E x 56	F x 7	G x 7
H x 12	I x 12	J x 2	K x 2	L x 2	M x 1	CL x 7
CR x 7	DL x 7	DR x 7				

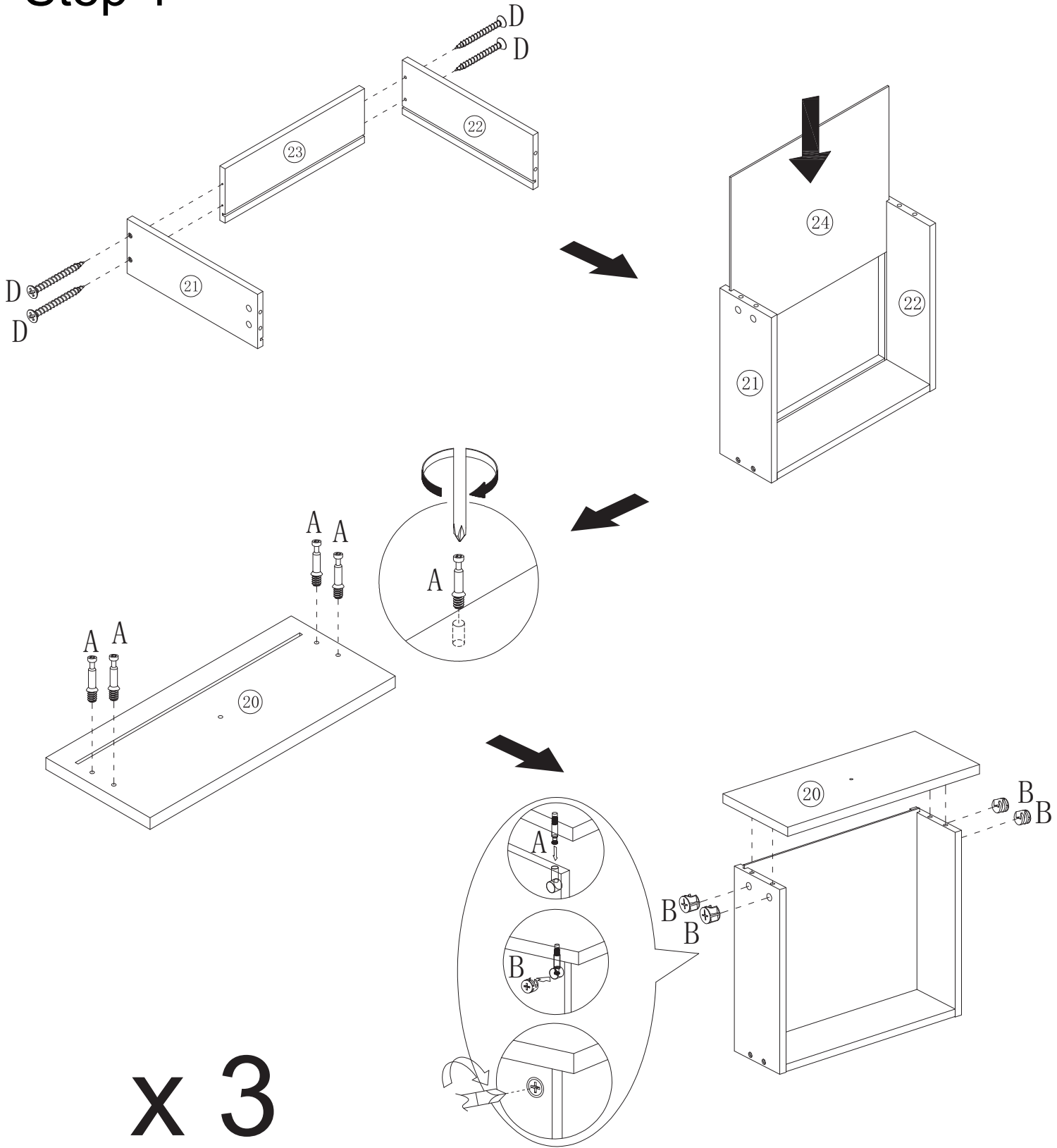
Step 1

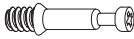

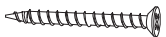
<p>∅6*35mm</p>  <p>A x 12</p>	<p>∅15*10mm</p>  <p>B x 12</p>	<p>∅4*40mm</p>  <p>D x 12</p>
--	--	--

Step 2

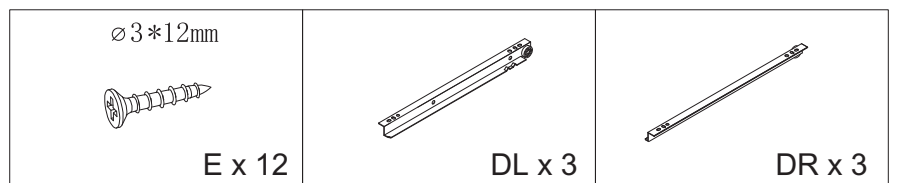
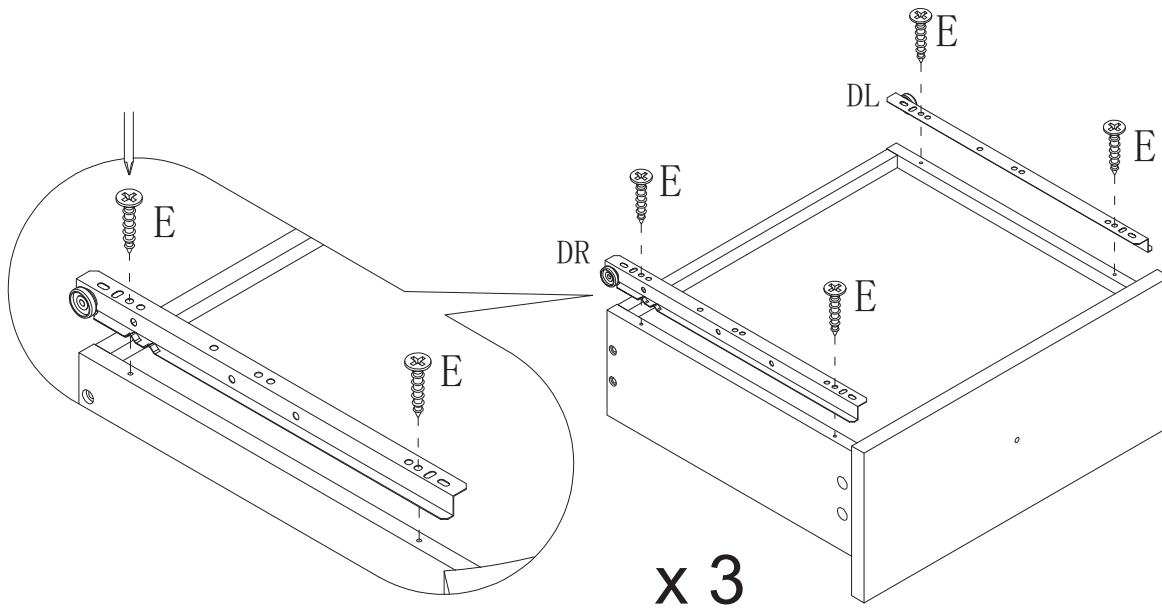

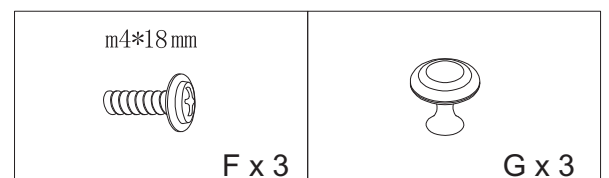
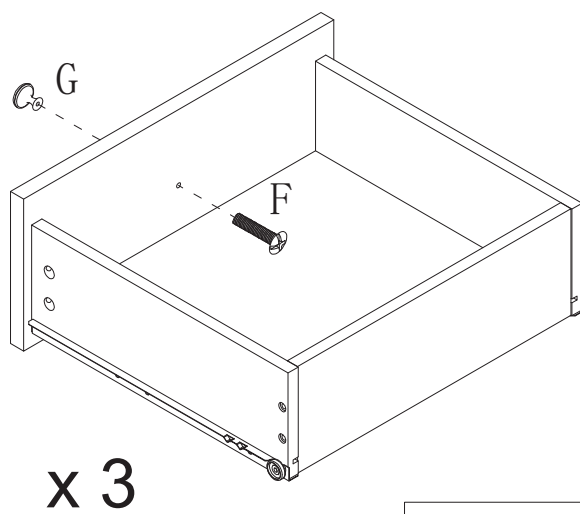

Step 3

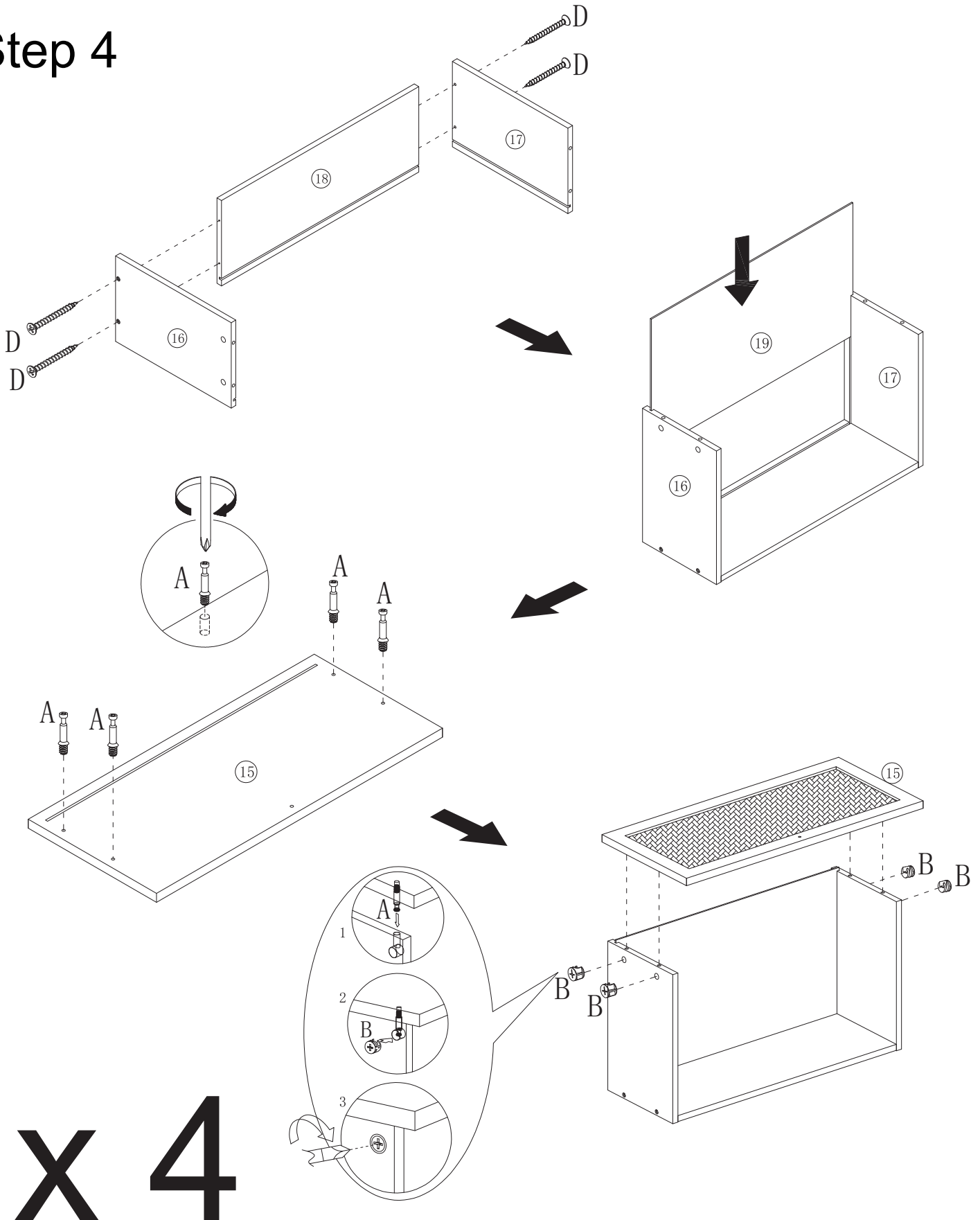

Step 4



<p>Ø6*35mm</p>  <p>A x 16</p>	<p>Ø15*10mm</p>  <p>B x 16</p>	<p>Ø4*40mm</p>  <p>D x 16</p>
--	---	--

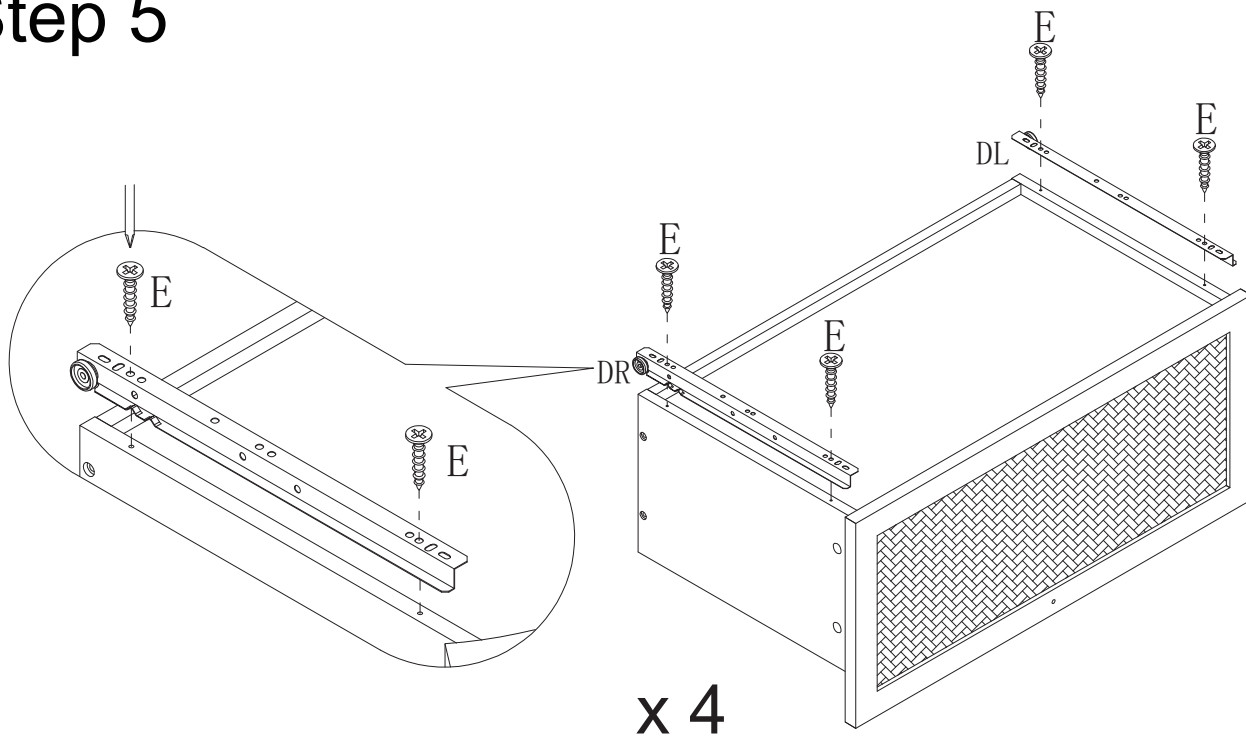

Step 5

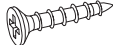
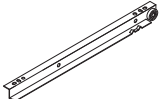
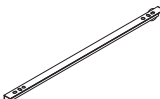

 ø 3*12mm E x 16	 DL x 4	 DR x 4
--	--	--

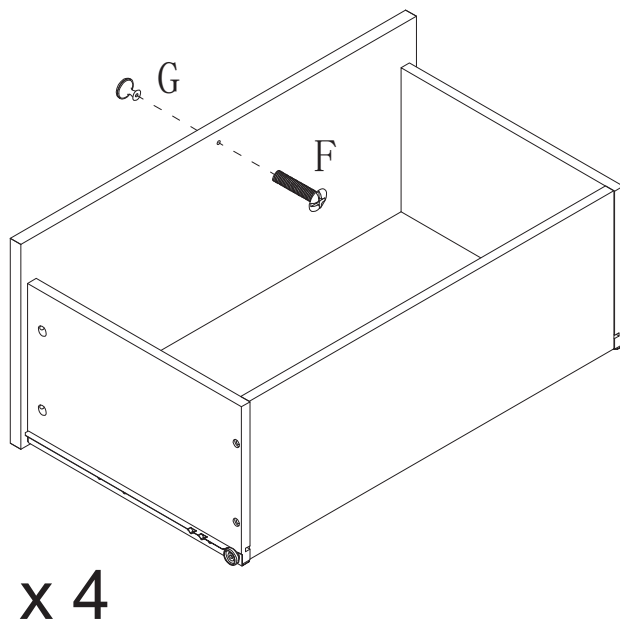
Step 6



 m4*18mm F x 4	 G x 4
---	--

Step 7

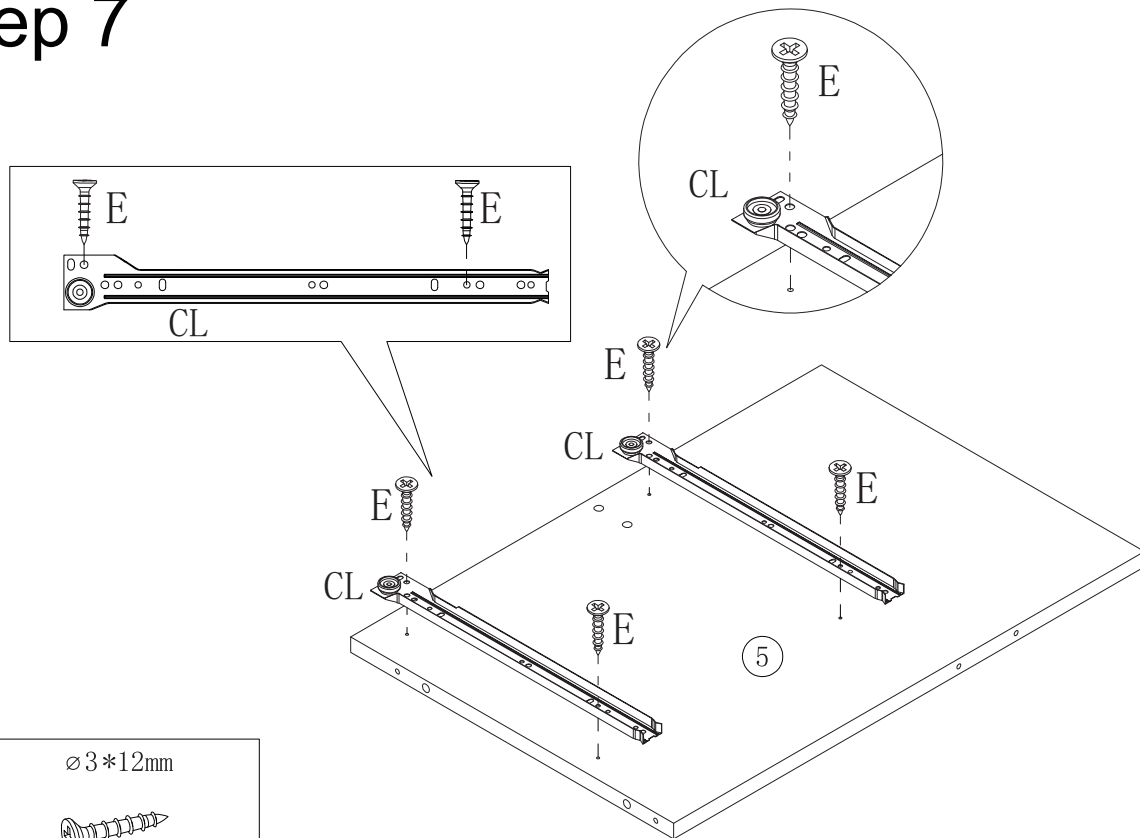

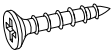
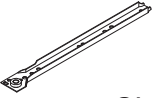
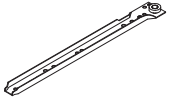
<p>ø3*12mm</p>  <p>E x 8</p>
 <p>CL x 2</p>
 <p>CR x 2</p>

Please flip to the other side of the board.

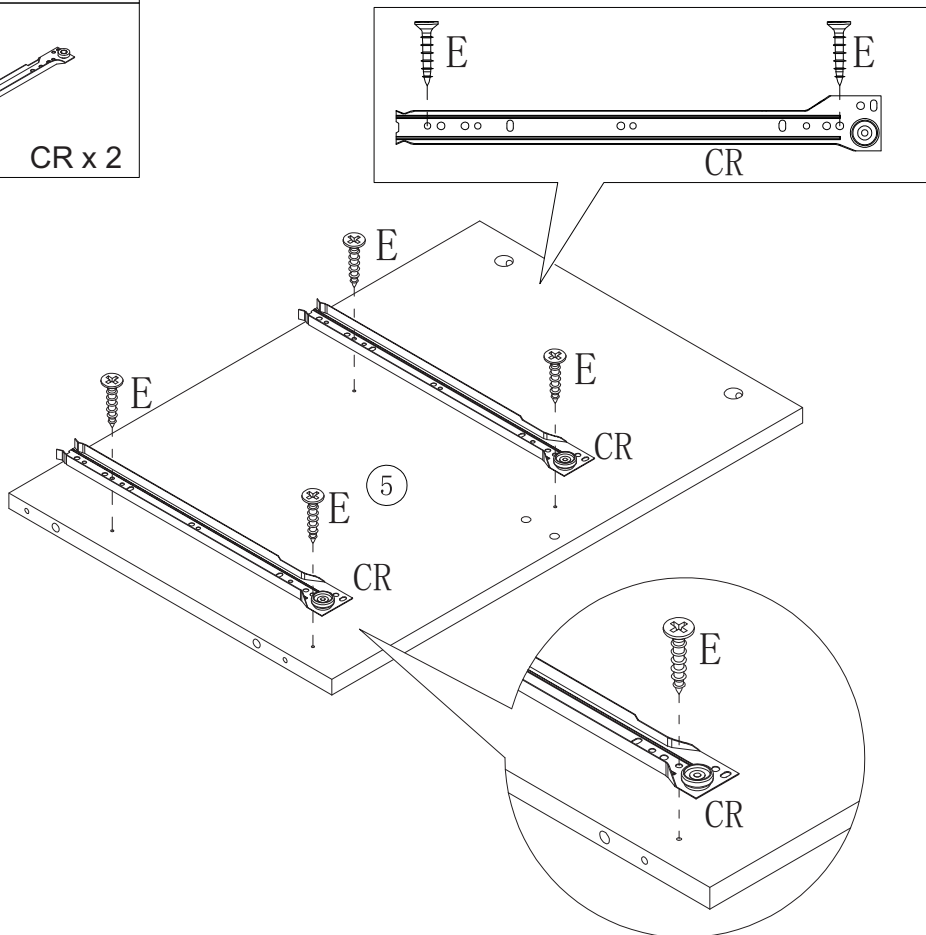

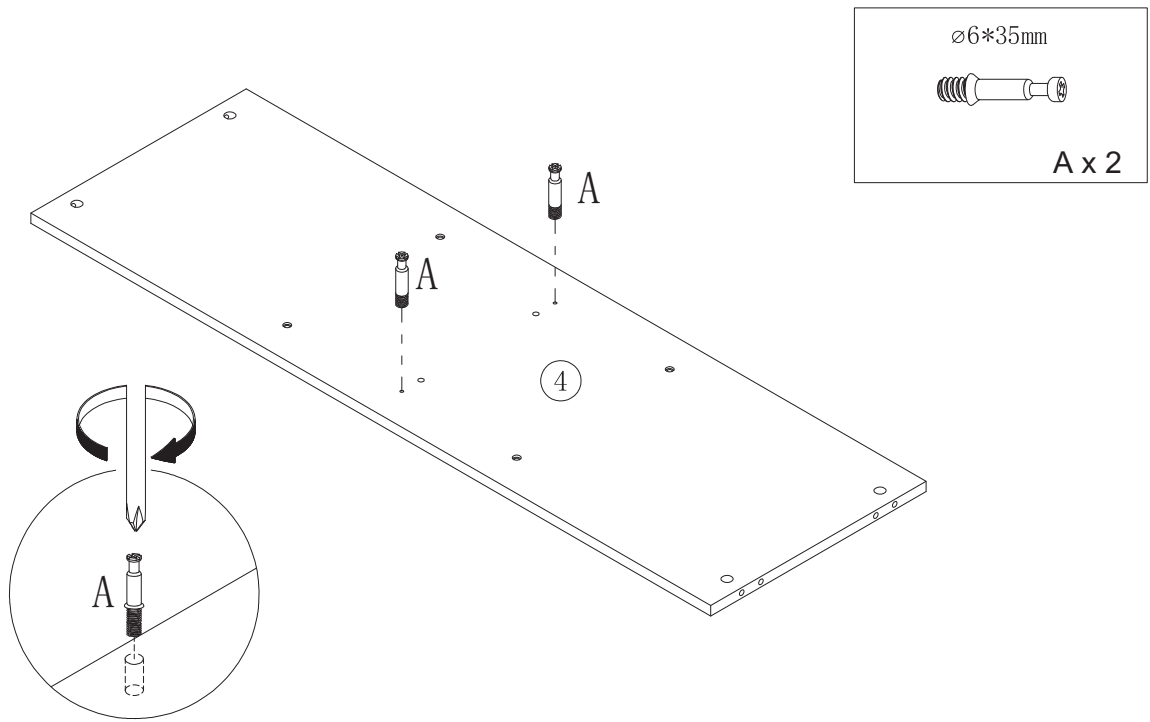

Step 8

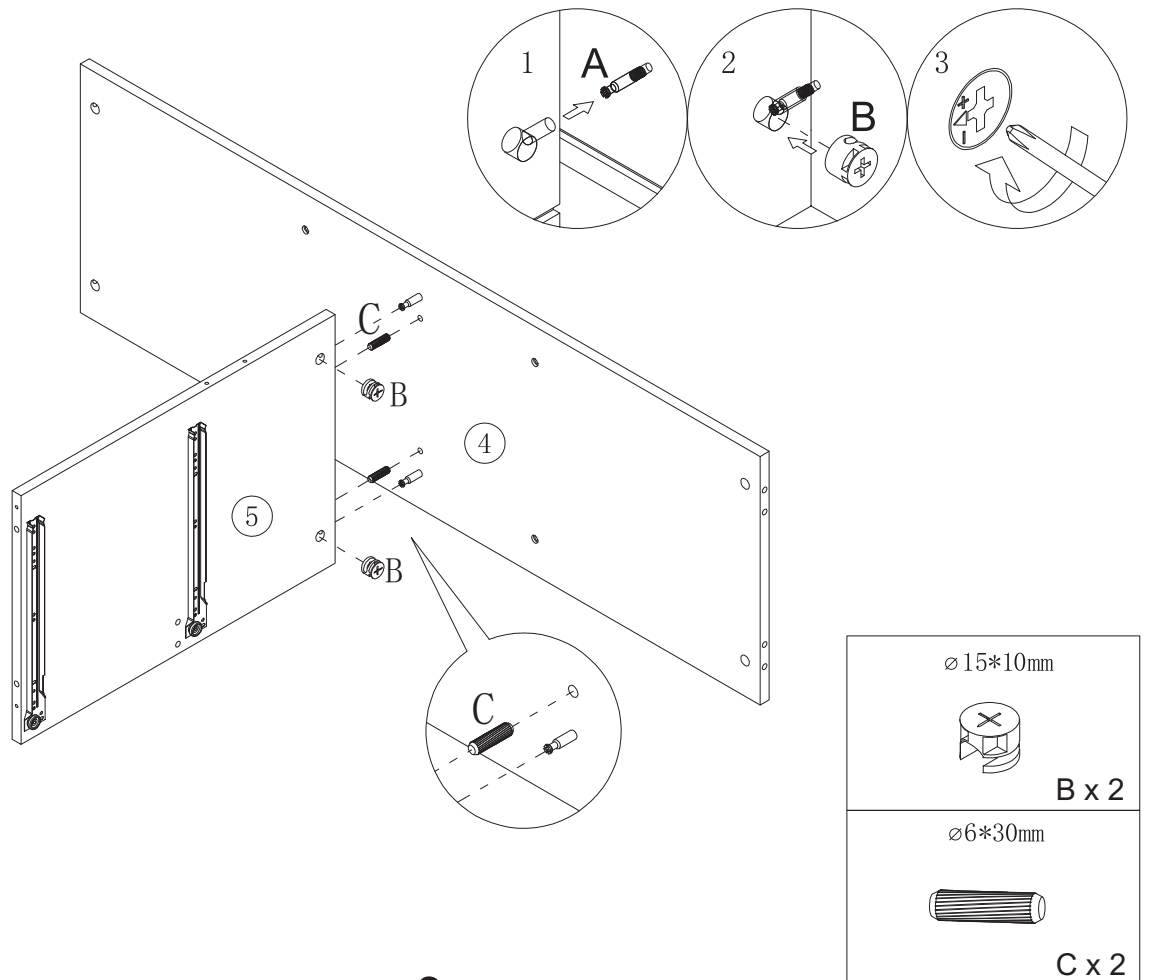

Step 9



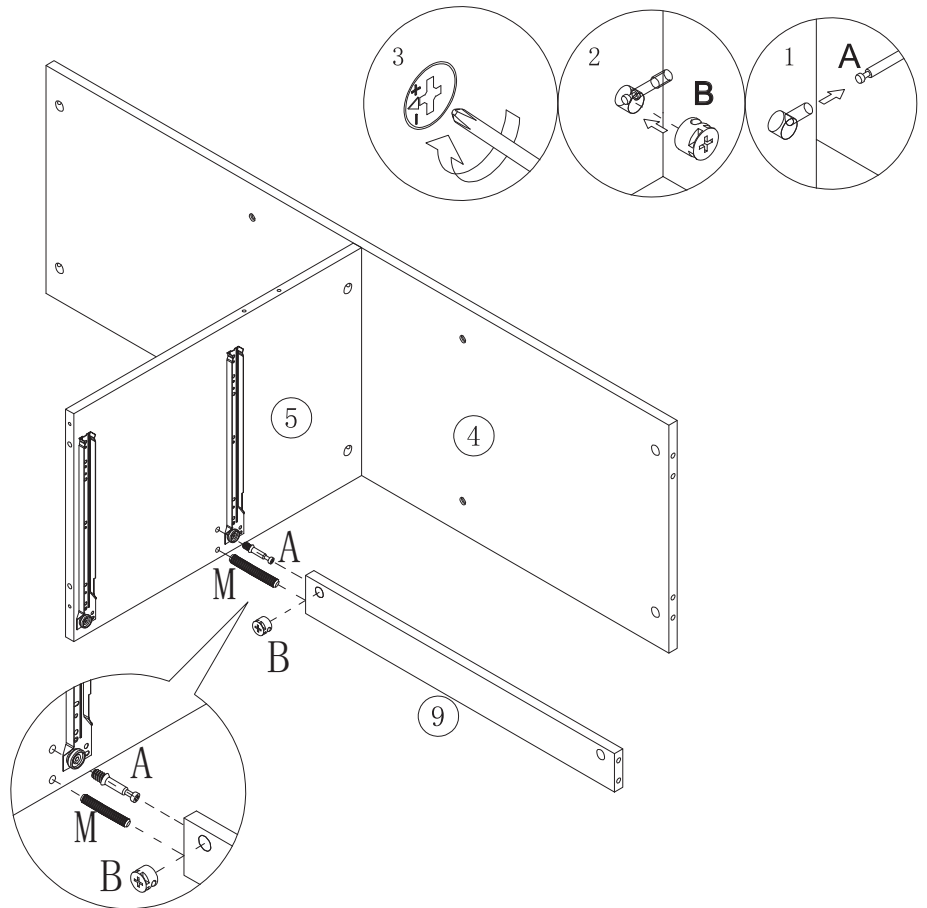

Step 10

 ø6*35mm
A x 1
 ø15*10mm
B x 1
 ø6*50mm
M x 1

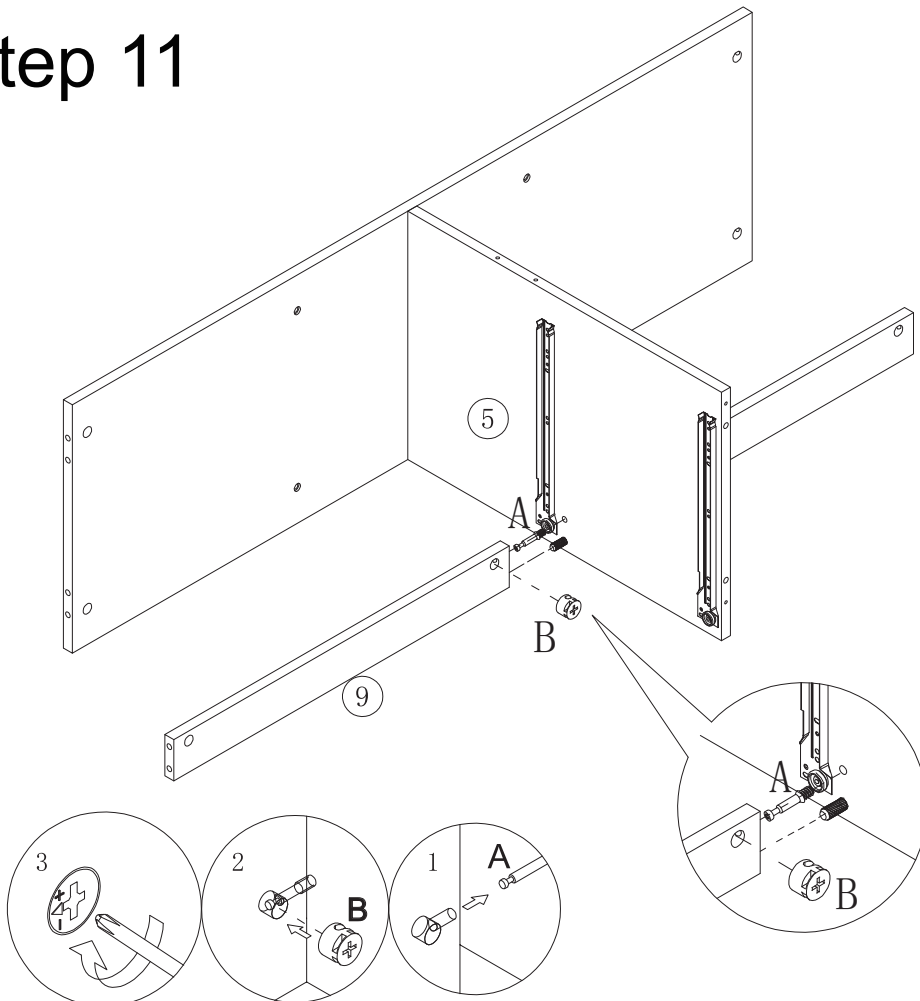

Step 11



 ø6*35mm
A x 1
 ø15*10mm
B x 1

Step 12

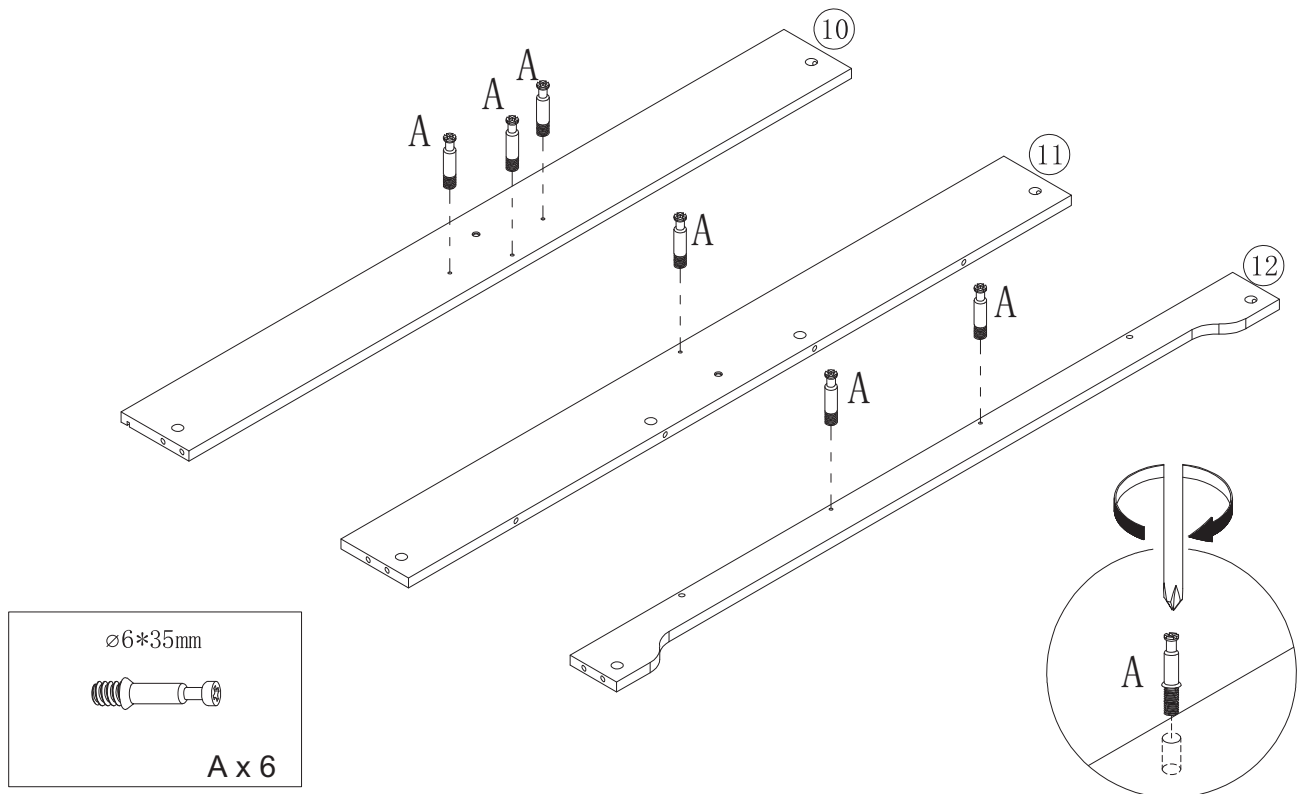

Step 13

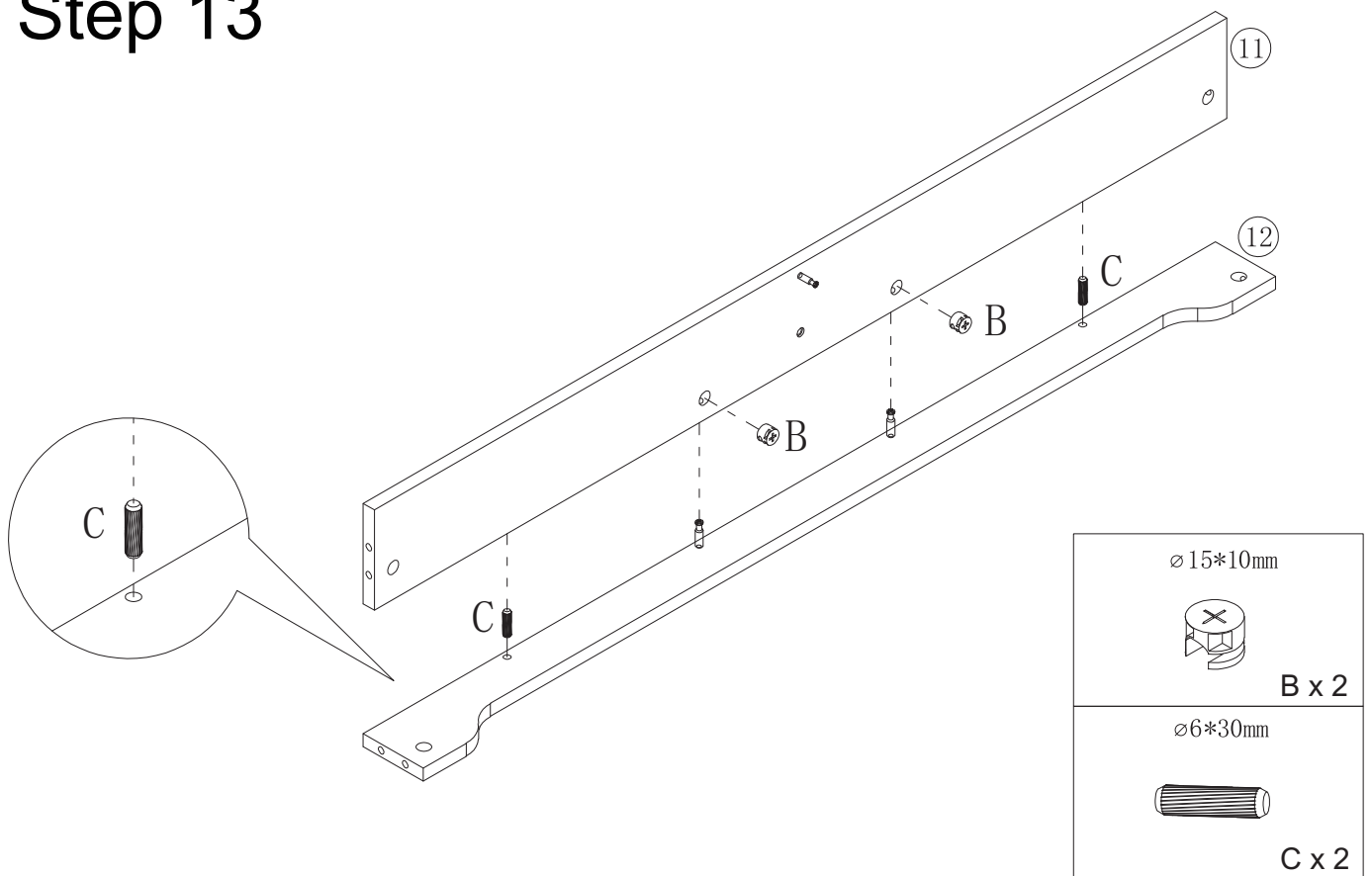

Step 14

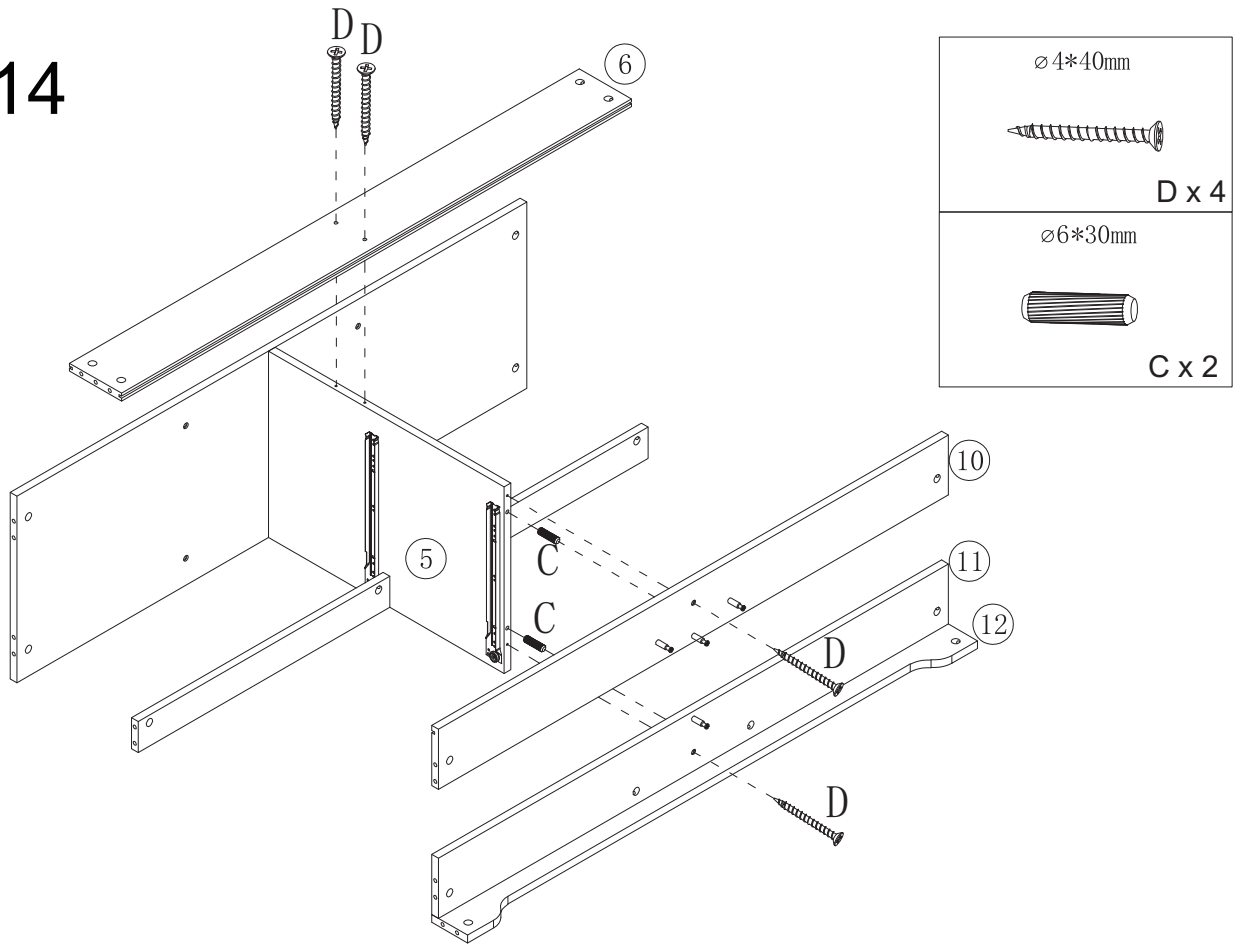

Step 15

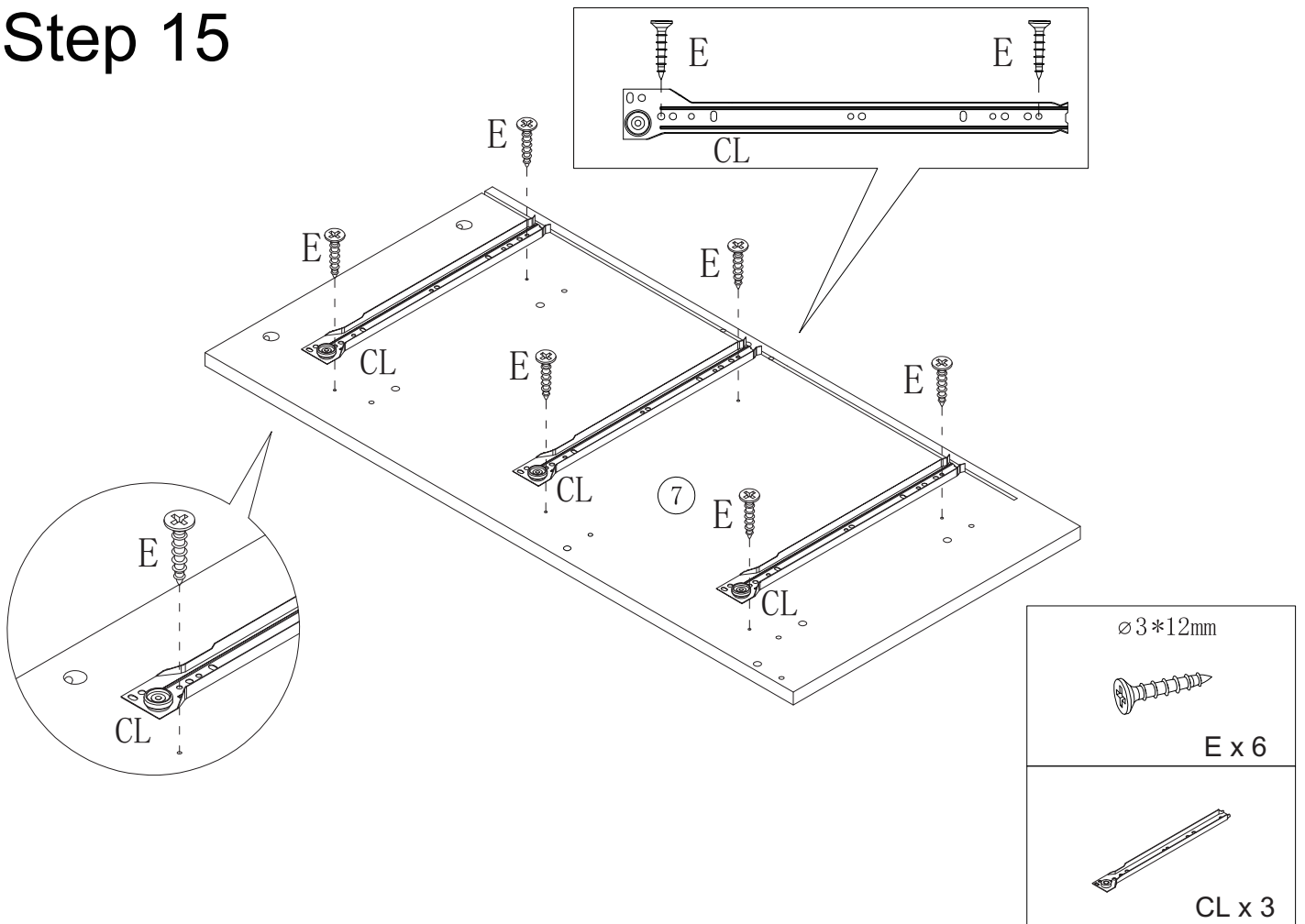

Step 16

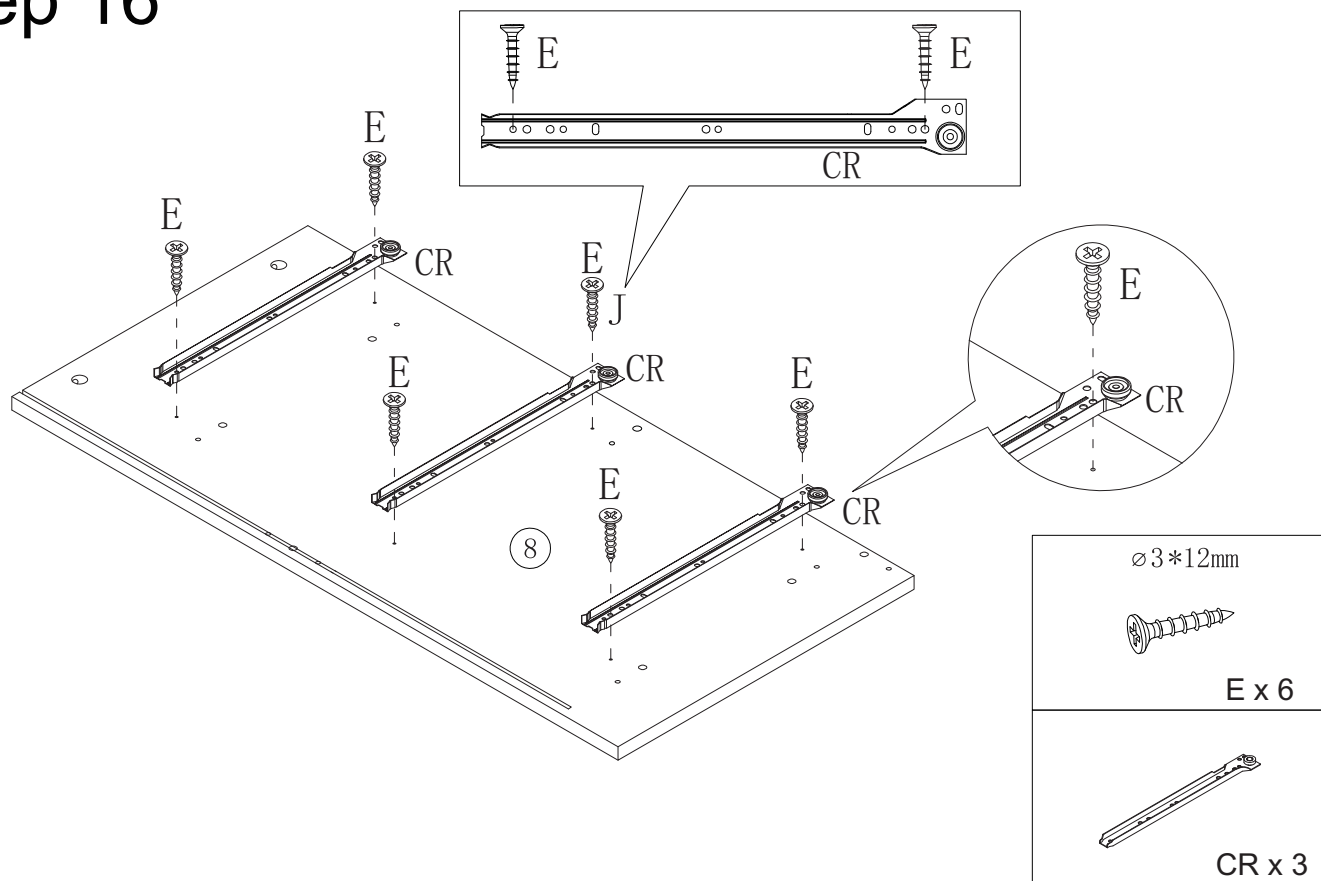

Step 17

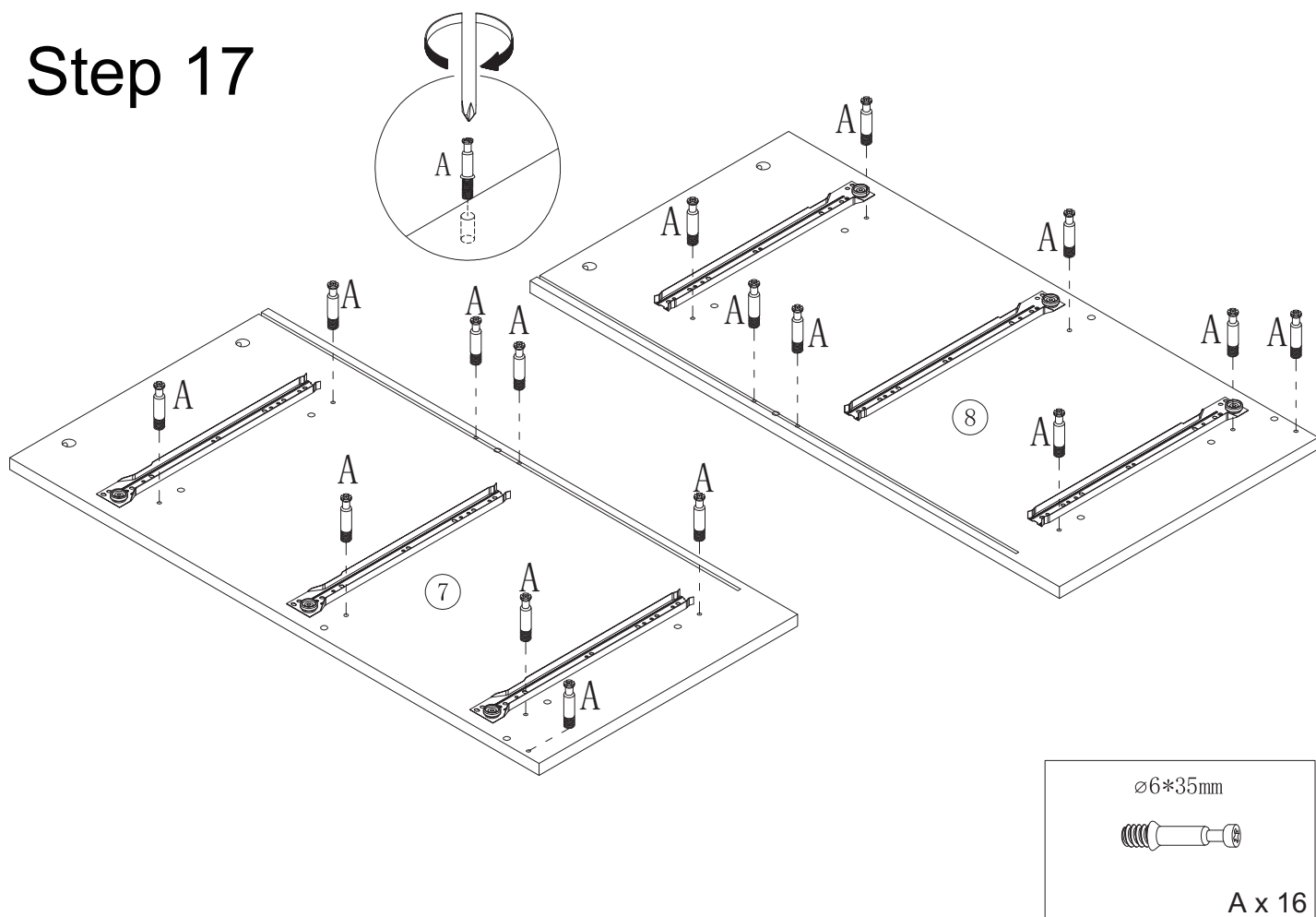

Step 18

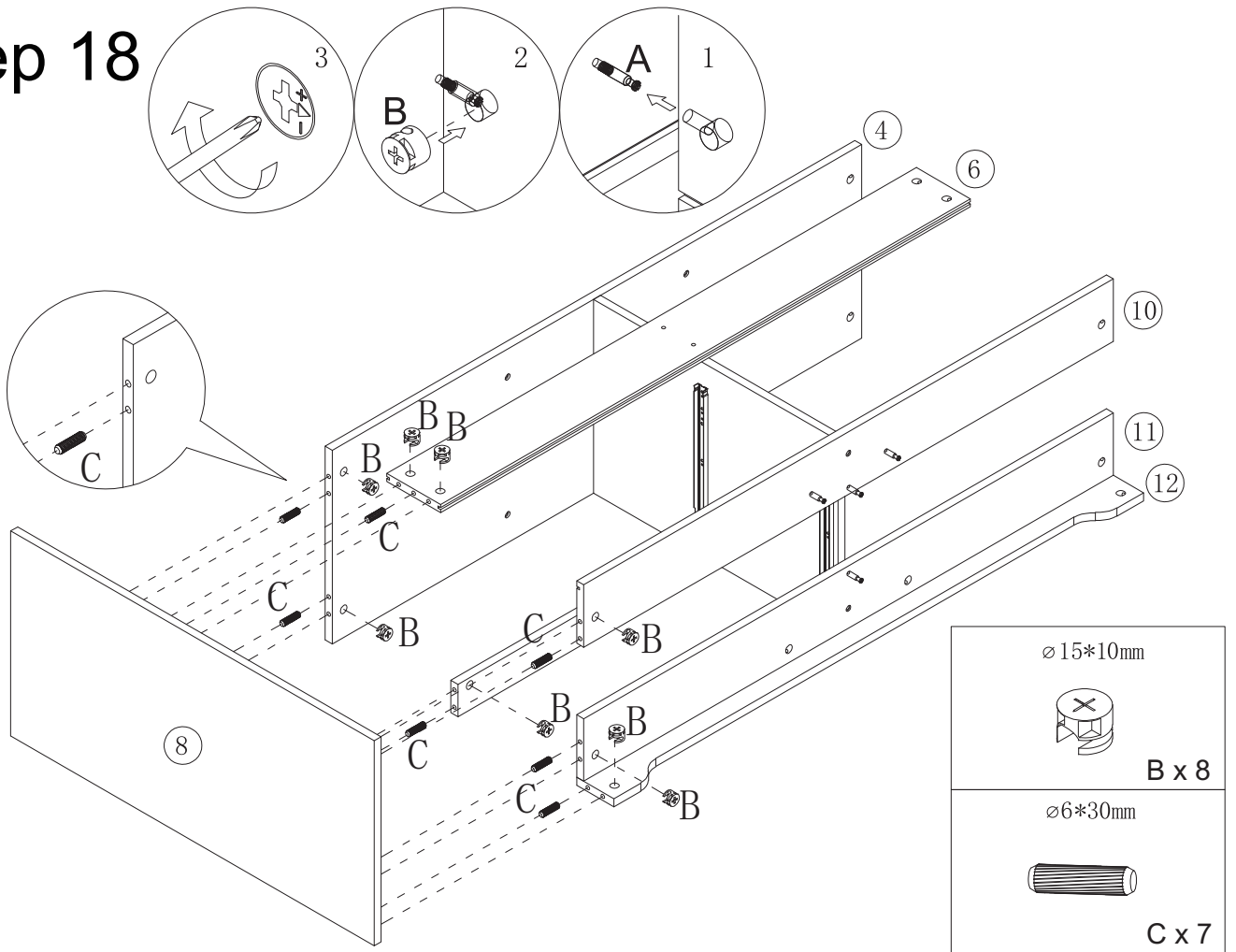

Step 19

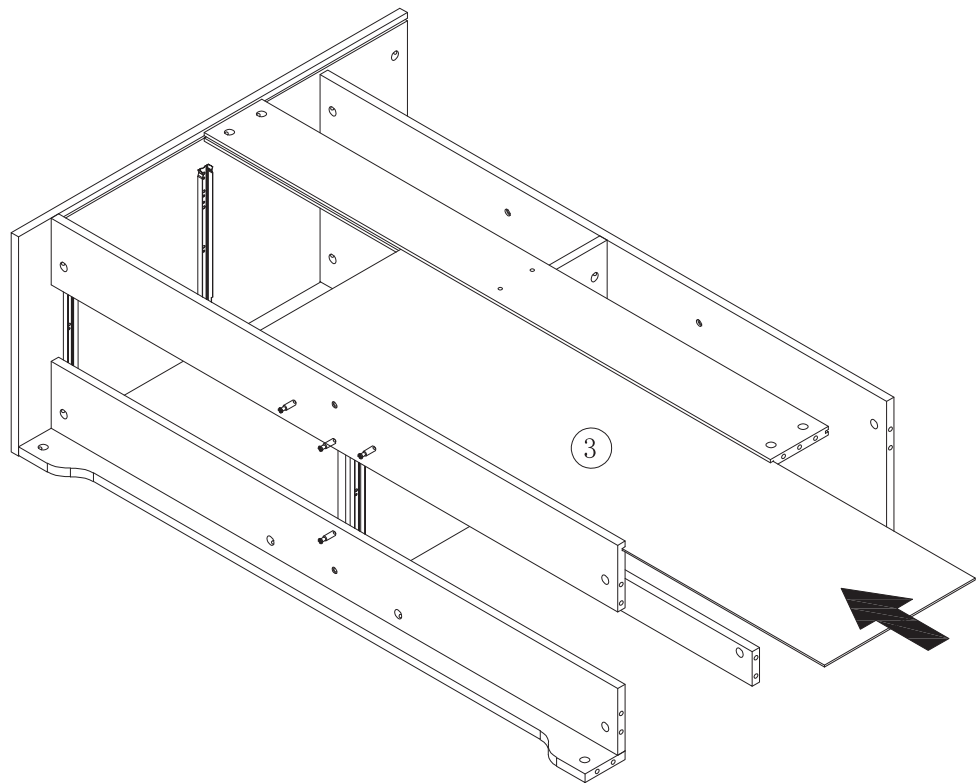

Step 20

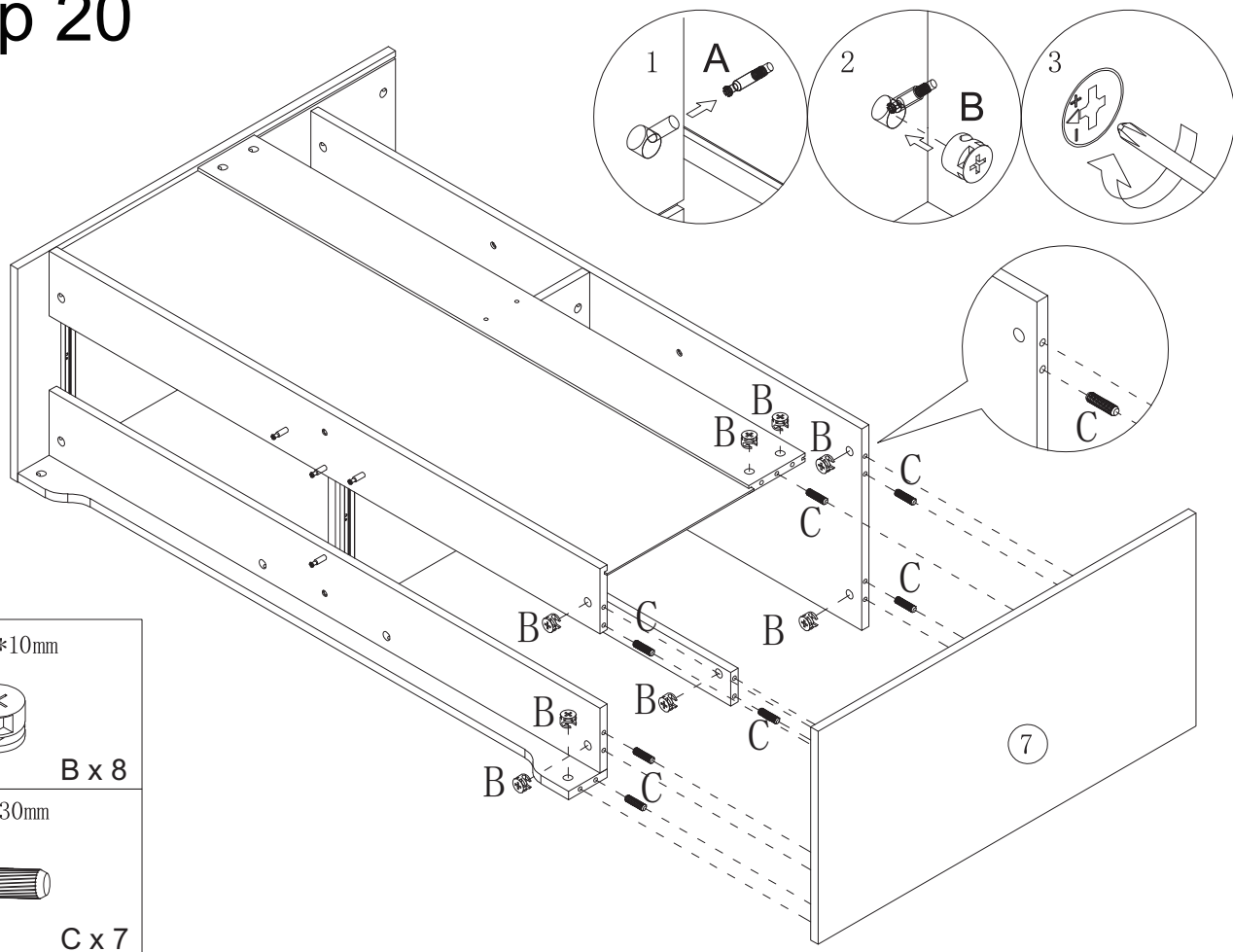

Step 21

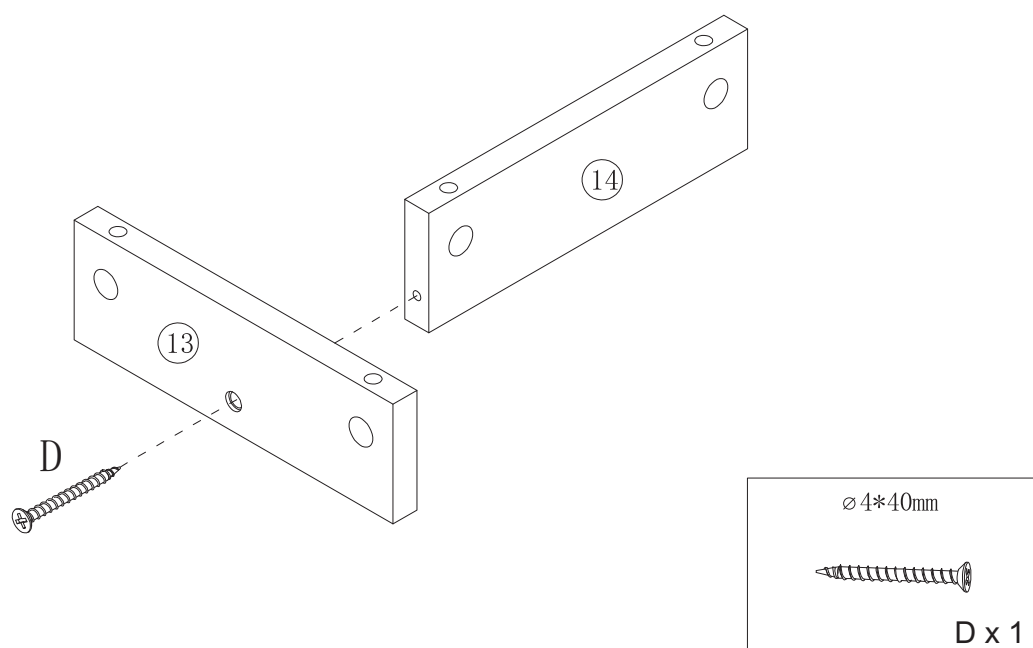

Step 22

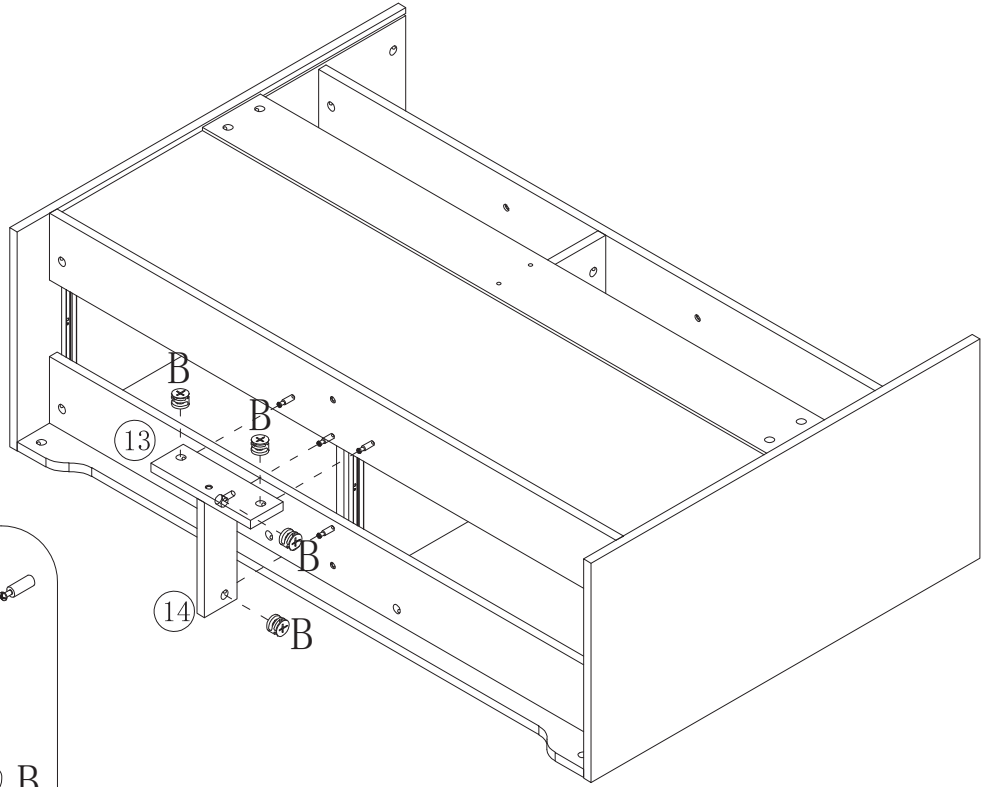
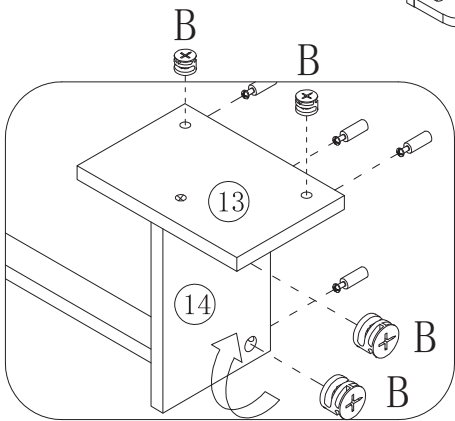
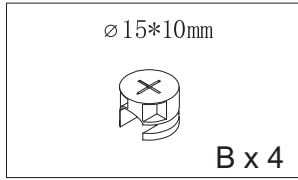

Step 23

x 2

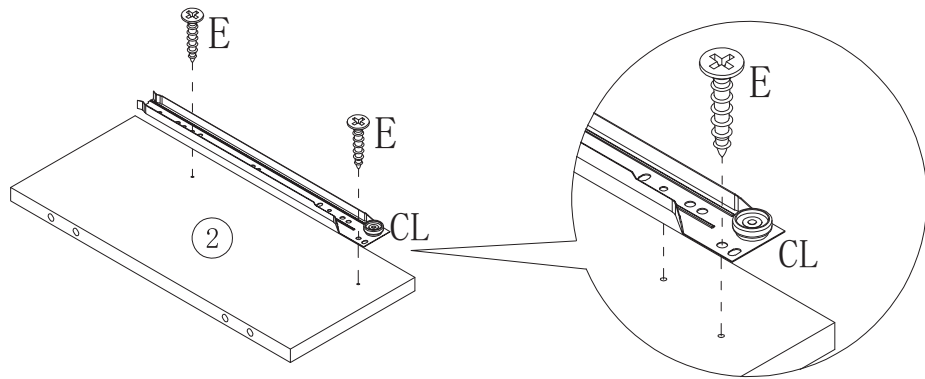

Please flip to the other side of the board.

x 2

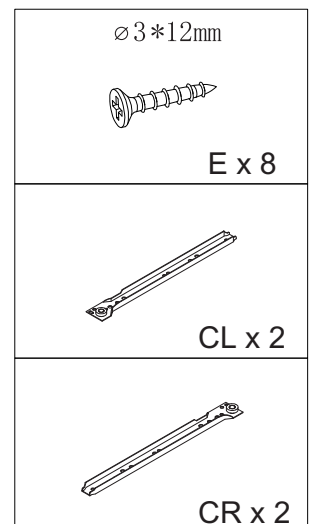
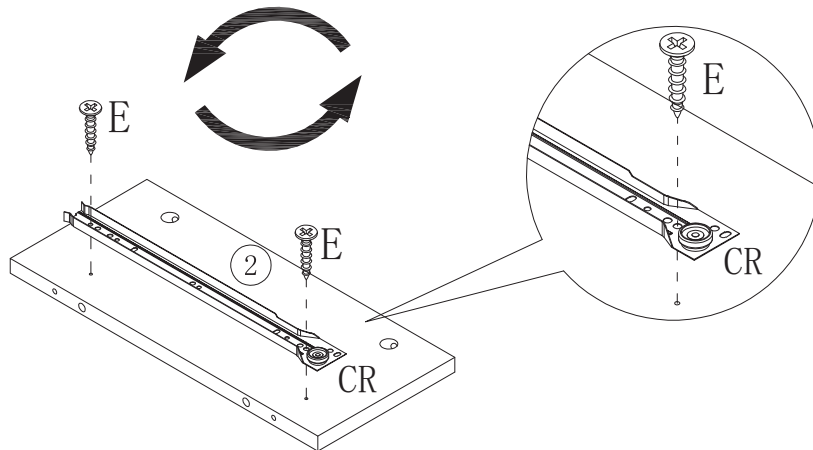

Step 24

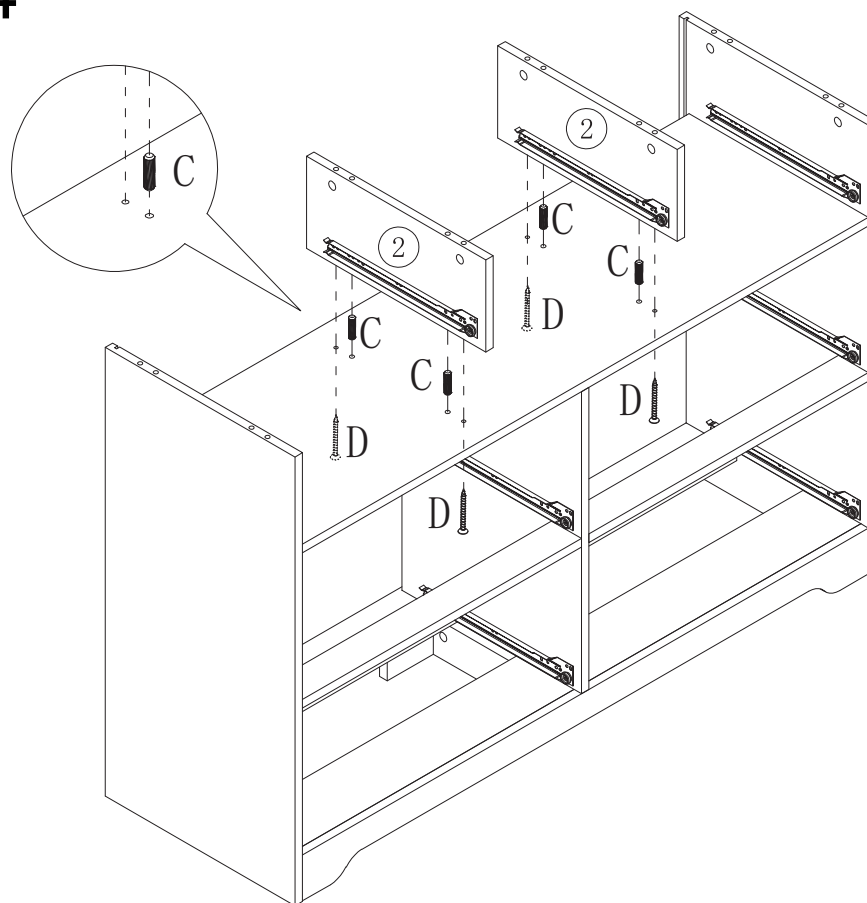

Step 25

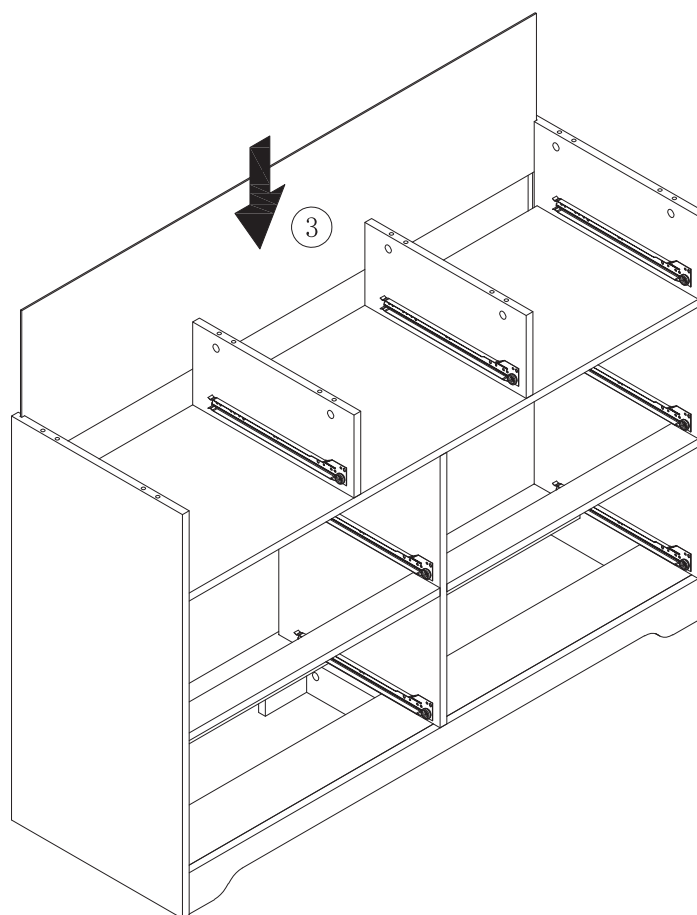

Step 26

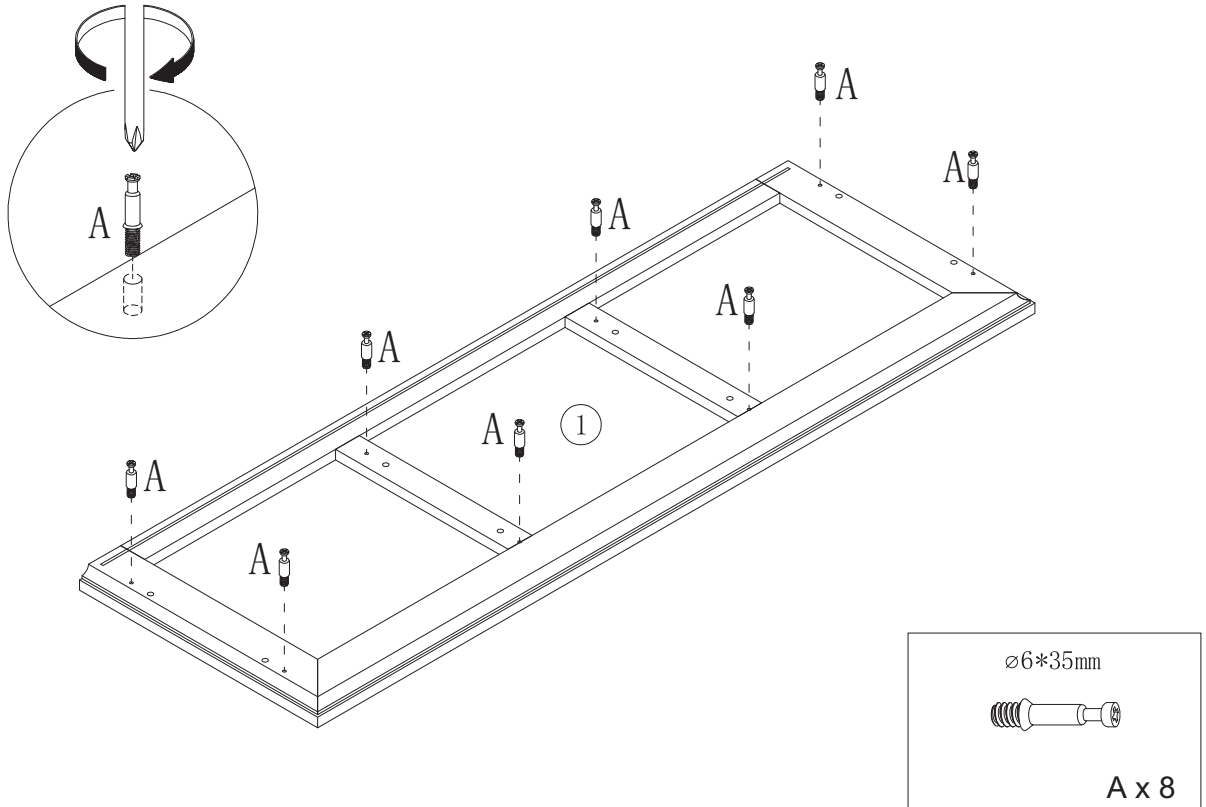

Step 27

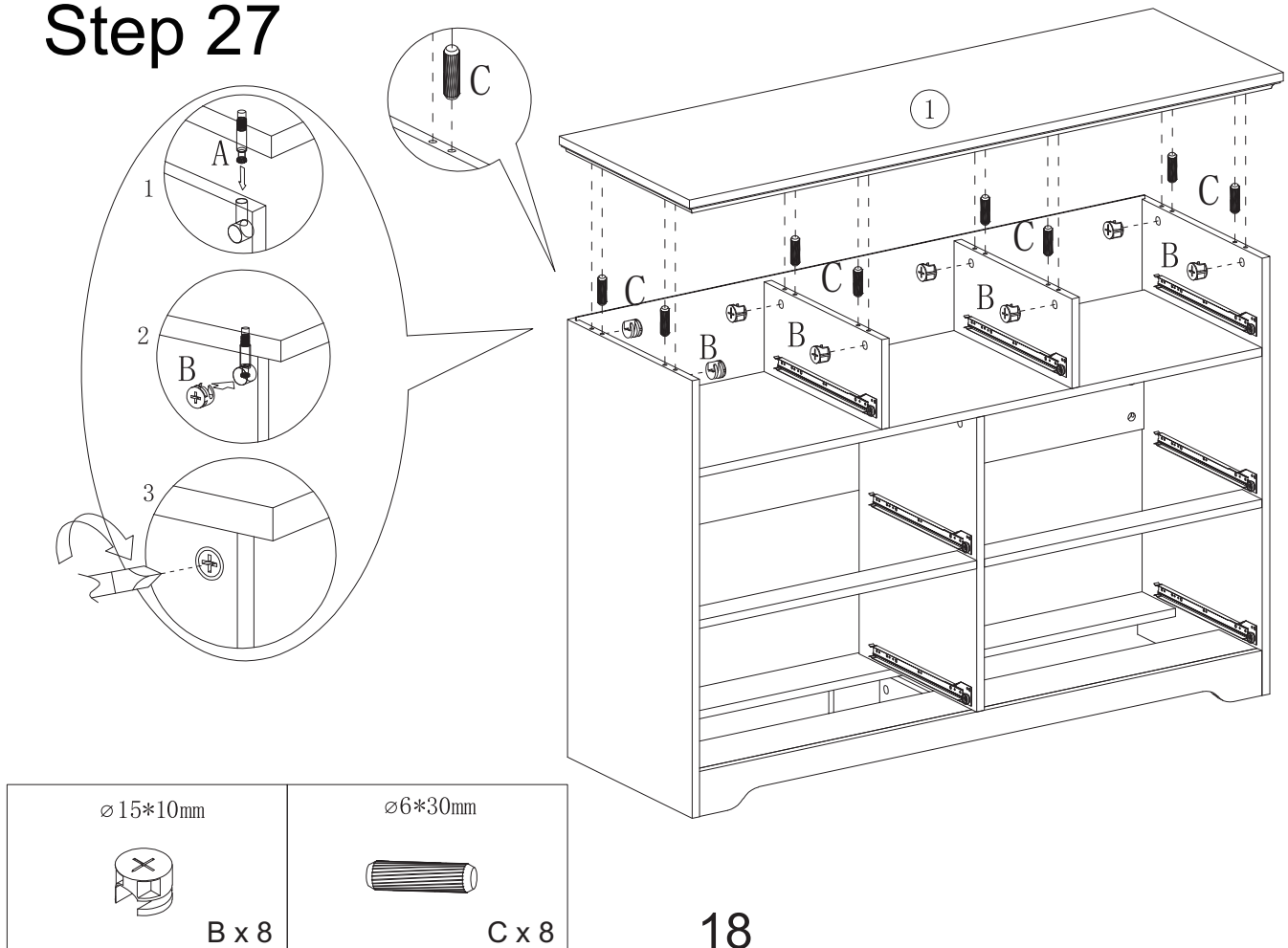

Step 28

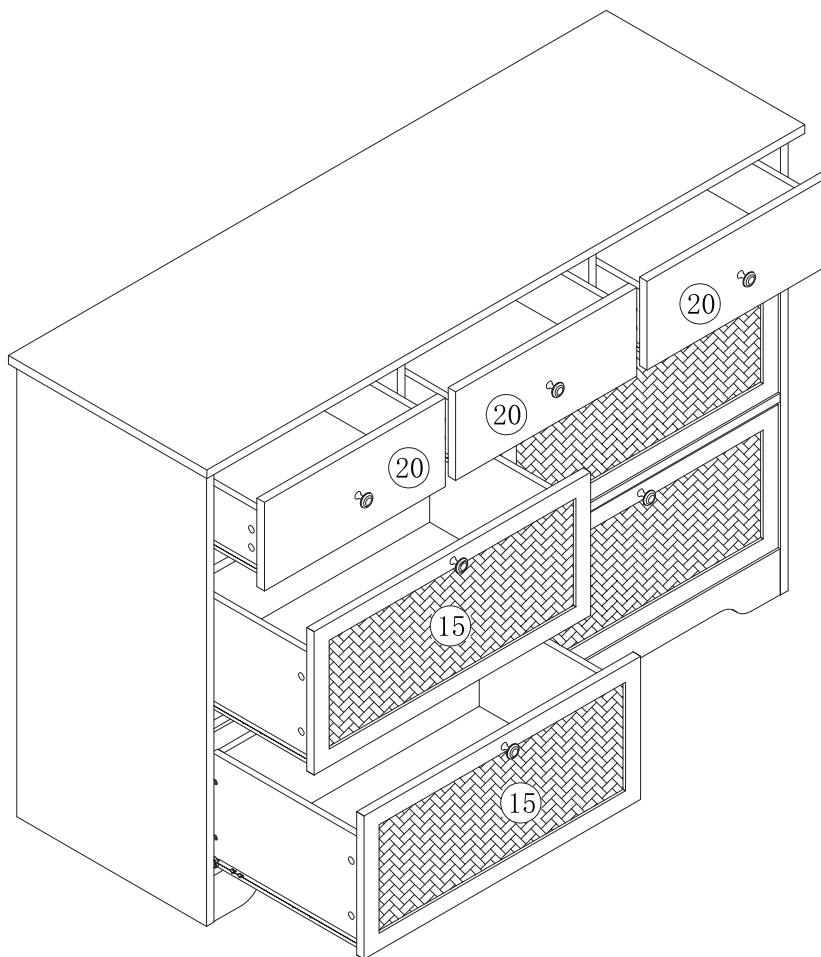
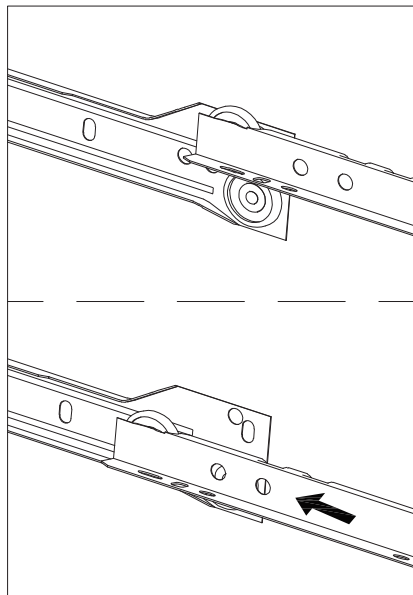

Step 29

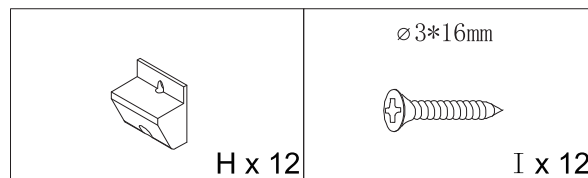
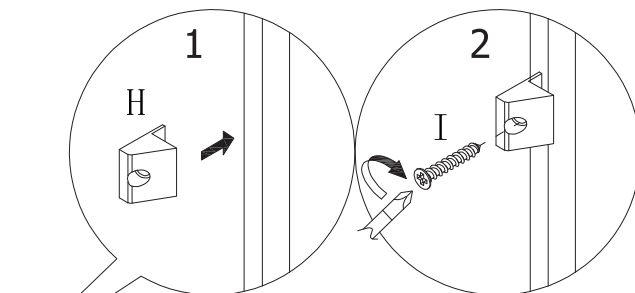
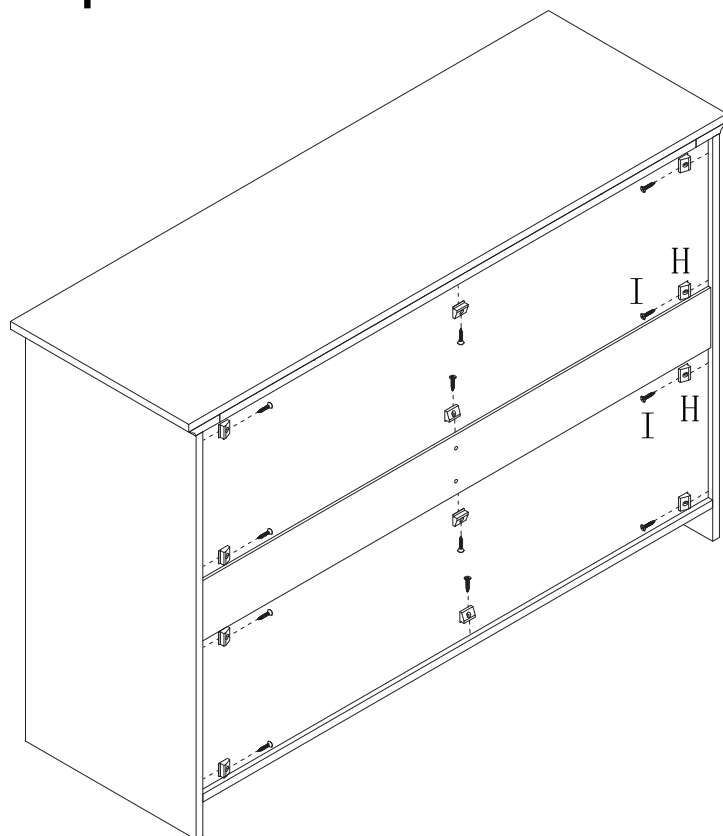

Step 30

