

# Assembly Instructions

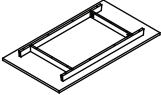

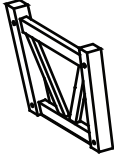
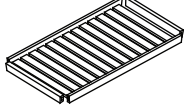

## 50" COFFEE TABLE

Thank you for purchasing this quality product. Be sure to check all packaging material carefully for small parts that may have come loose inside the carton during shipment.

### COMPONENT LIST:

FIGURE	DESCRIPTION	QTY
	Hardware Bag	1 pce
	Table Top	1 pce
	Trestle Base	2 pcs
	Fixed Shelf	1 pce

### HARDWARE LIST:

PART NO	FIGURE	DESCRIPTION	QTY
1		JCBC Bolt	8 pcs
2		Lock Washer	8 pcs
3		Flat Washer	8 pcs
4		Wood Button	8 pcs
5		Allen Key	1 pce

This product will take 15-20 minutes to assemble.

#### Reminders

1. Use only the hardware supplied.
2. Once the product is assembled, level and tighten all the bolts.
3. Do not over-tighten bolts.
4. This item may require periodic tightening

#### NOTE:

1. Two or two people are needed for assembly
2. Please keep all hardware parts out of the reach of children.

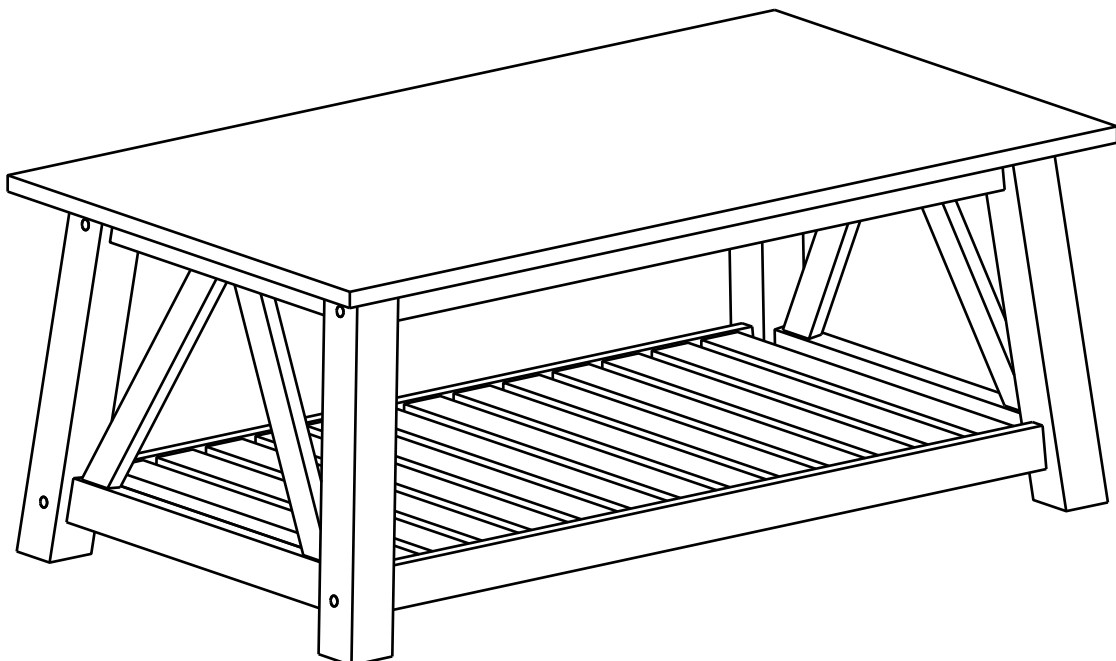

# Assembly Instructions

## 50" COFFEE TABLE

### ASSEMBLY :

#### STEP 1

- 1.1-Turn the Table Top upside down on a protective surface such as carpet or other soft material.
- 1.2-Attach the Trestle Base to Table Top by inserting the wood dowel on table top the pre-drilled holes on the Trestle Base.
- 1.3-Attach Trestle Base to Table Top Flat Washer(3),Lock Washer(2),JCBC Bolt(1) and tighten using Allen Key(5).

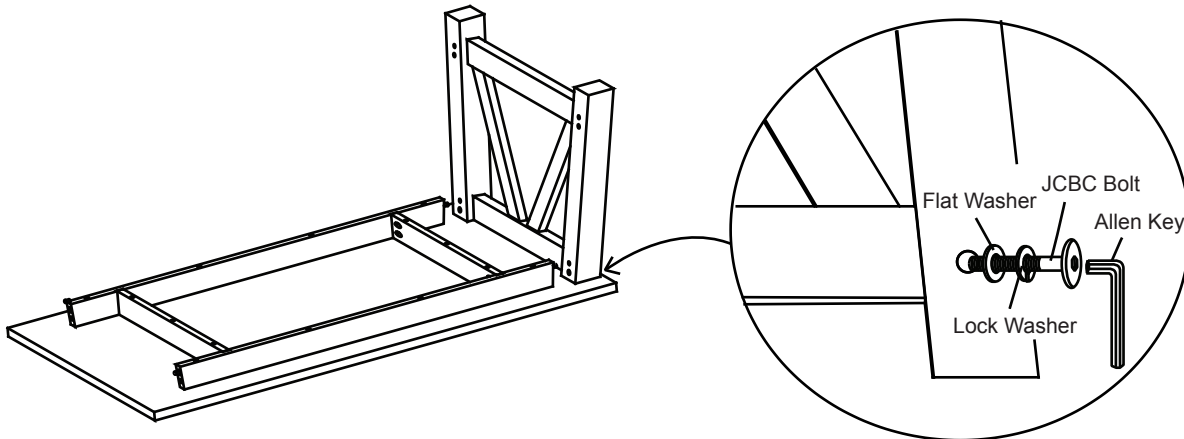

Fig.1

#### STEP 2

- 2.1-Insert the Fixed Shelf into the Trestle Base by inserting the wood dowel on Fixed Shelf into the pre-drilled holes on the Trestle Base.
- 2.2-Attach Fixed Shelf and Trestle Base using Flat Washer(3),Lock Washer(2),JCBC Bolt(1) and tighten using Allen Key(5).

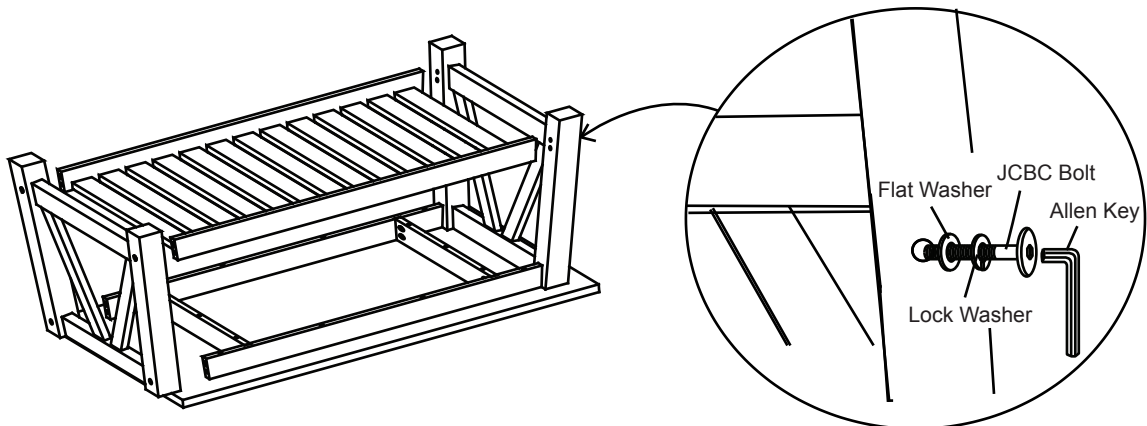

Fig.2

#### STEP 3

- 3.1- Turn table to upright position.
- 3.2- Once coffee table is fully balance fully tighten all bolts.
- 3.3- Insert Wood Plug (4) into the bolts holes on trestle to complete the assembly

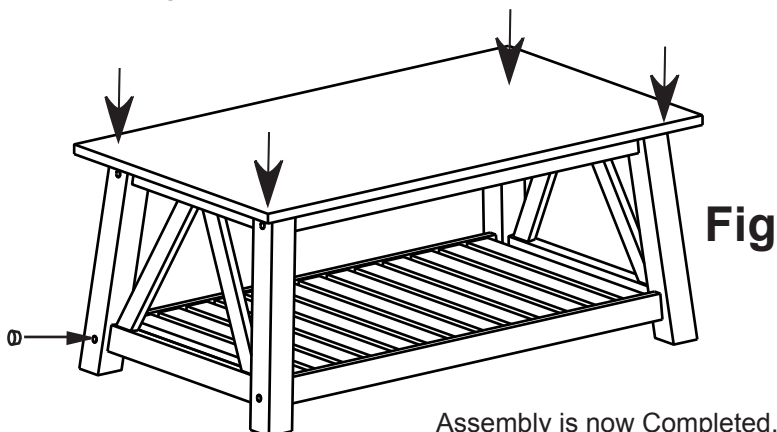

Fig.3

#### CARE INSTRUCTION

- ~ Be sure to use the same type of polish consistently. Your furniture will appear cloudy or streaky if oil based or wax based polishes are interchanged.
- ~ Spray your furniture surface evenly. Wipe in a circular motion with a soft clean cloth.