

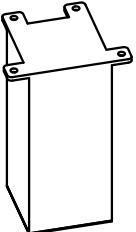
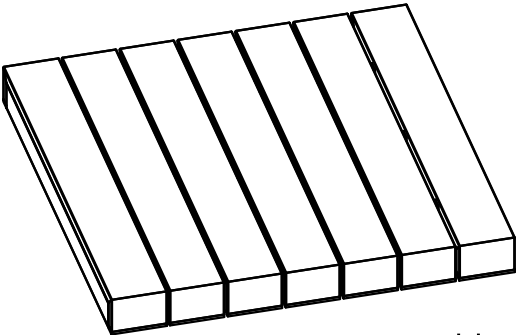
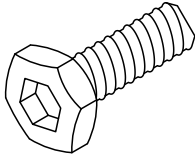
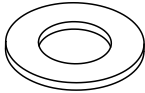

# Assembly Instructions

Please read this before you proceed.

NUMBER	COMPONENT	QUANTITY
A	 <p data-bbox="677 726 840 766">Table Legs</p>	4PCS
B	 <p data-bbox="688 1141 840 1181">Table Top</p>	1PC

# Assembly Instructions

NUMBER	COMPONENT	QUANTITY
AA	 <p data-bbox="676 475 840 507">Bolt M6*20</p>	16+1PCS
BB	 <p data-bbox="613 683 840 715">M6 Flat washer</p>	16+2PC
CC	 <p data-bbox="650 885 840 917">M6 Allen Key</p>	1PC

# Assembly Instructions

①

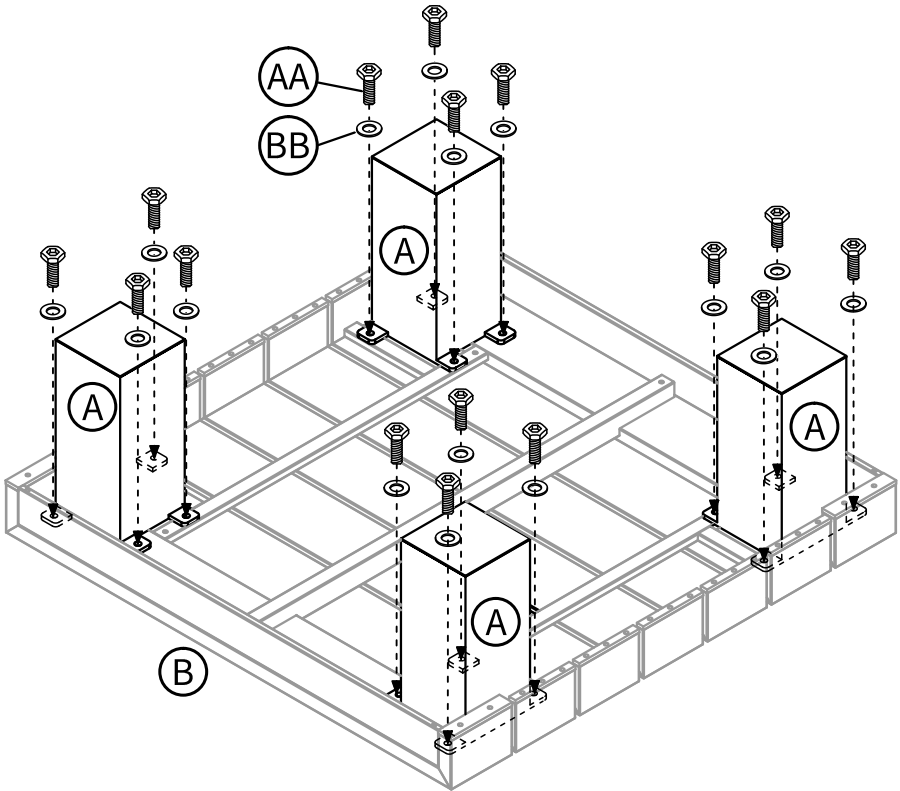

1. Place Table Top (B) top-down.
2. Attach one (1) Table Leg (A) at each corner using four (4) M6\*20 Bolts (AA) and four (4) M6 Flat Washers (BB) each.
3. Flip the assembly over.