



VESTIL MANUFACTURING COMPANY

2999 North Wayne Street, P.O. Box 507, Angola, IN 46703

Telephone: (260) 665-7586 -or- Toll Free (800) 348-0868

Fax: (260) 665-1339

www.vestil.com

info@vestil.com

TCD -Series Trash Can Dumpers

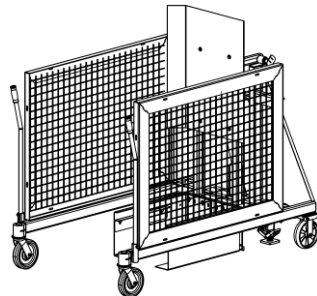

TCD-M

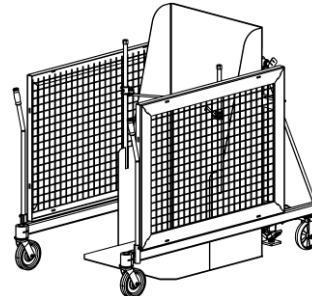

TCD-U

RECEIVING INSTRUCTIONS

After delivery, remove the packaging from the product. Inspect the product closely to determine whether it sustained damage during transport. If damage is discovered, record a complete description of it on the bill of lading. If the product is undamaged, discard the packaging.

NOTE: The end-user is solely responsible for confirming that product design, use, and maintenance comply with laws, regulations, codes, and mandatory standards applied where the product is used.

TECHNICAL SERVICE & REPLACEMENT PARTS

For answers to questions not addressed in these instructions or to order replacement parts, labels, and accessories, contact our Technical Service and Parts Department at (260) 665-7586. You can also reach the department online at <https://www.vestil.com/page-parts-request.php>.

ELECTRONIC COPIES OF INSTRUCTION MANUALS

Additional copies of this instruction manual can be downloaded from <https://www.vestil.com/page-manuals.php>.

Table of Contents

	Page
TCD-M Specifications.....	2
TCD-U Specifications.....	3
Signal Words.....	4
Safety Instructions.....	4
Exploded Views and Bills of Materials.....	5, 6, 7, 8
*Power Unit Operation.....	9
*Cleaning the Lowering Solenoid Valve.....	9 – 10
*Bleeding Air from the Hydraulic System.....	10
*Hydraulic Circuit Diagram.....	10
*Electric Circuit Diagrams.....	11 – 12
*DC Modular Power Unit Exploded View and Bill of Materials.....	13
*AC Modular Power Unit Exploded View and Bill of Materials.....	14
Using the Trash Can Dumper.....	15
Record of Satisfactory Condition (TCD-M).....	16
Inspections (TCD-M).....	16
Record of Satisfactory Condition (TCD-U).....	17
Inspections (TCD-U).....	17
Troubleshooting.....	18
Labeling Diagrams.....	19
Limited Warranty.....	20

NOTE: Trash can dumpers manufactured after 12-01-2018 receive a 2nd generation modular power unit (MPU GEN2). Diagrams and operating instructions for GEN2 power units are provided in separate MPU-AC/DC manuals.

TCD-M Specifications

Dimensions, capacities, and net weights appear in the following diagrams and table.

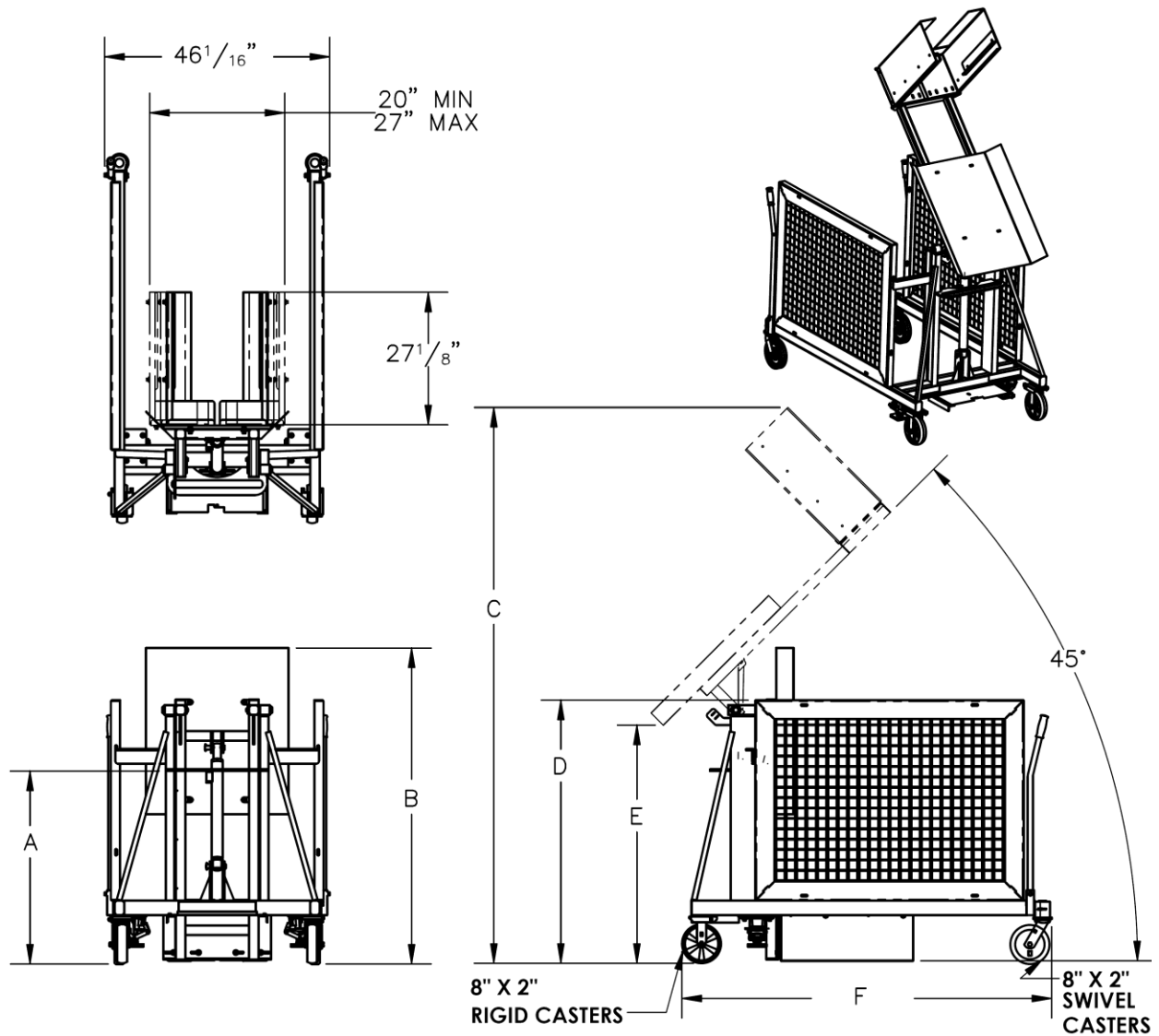

Model	A	B	C	D	E	F	Capacity	Net Weight
TCD-M-48-AC	39 1/2" 101 cm	64 11/16" 165 cm	113 13/16" 289 cm	53 7/8" 137 cm	48 3/4" 124 cm	75 5/8" 192 cm	400 lb. 182 kg	554 lb. 252 kg
TCD-M-48-DC	39 1/2" 101 cm	64 11/16" 165 cm	113 13/16" 289 cm	53 7/8" 137 cm	48 3/4" 124 cm	75 5/8" 192 cm	400 lb. 182 kg	554 lb. 252 kg
TCD-M-60-AC	41" 105 cm	77 9/16" 197 cm	134 11/16" 343 cm	65 11/16" 167 cm	60 3/8" 154 cm	75 5/8" 192 cm	400 lb. 182 kg	583 lb. 265 kg
TCD-M-60-DC	41" 105 cm	77 9/16" 197 cm	134 11/16" 343 cm	65 11/16" 167 cm	60 3/8" 154 cm	75 5/8" 192 cm	400 lb. 182 kg	583 lb. 265 kg
TCD-M-72-AC	53" 135 cm	89 9/16" 228 cm	155 5/16" 395 cm	77 11/16" 198 cm	72 3/8" 184 cm	87 5/8" 223 cm	400 lb. 182 kg	641 lb. 292 kg
TCD-M-72-DC	53" 135 cm	89 9/16" 228 cm	155 5/16" 395 cm	77 11/16" 198 cm	72 3/8" 184 cm	87 5/8" 223 cm	400 lb. 182 kg	641 lb. 292 kg

TCD-U Specifications

Dimensions, capacities, and net weights appear in the following diagrams and table.

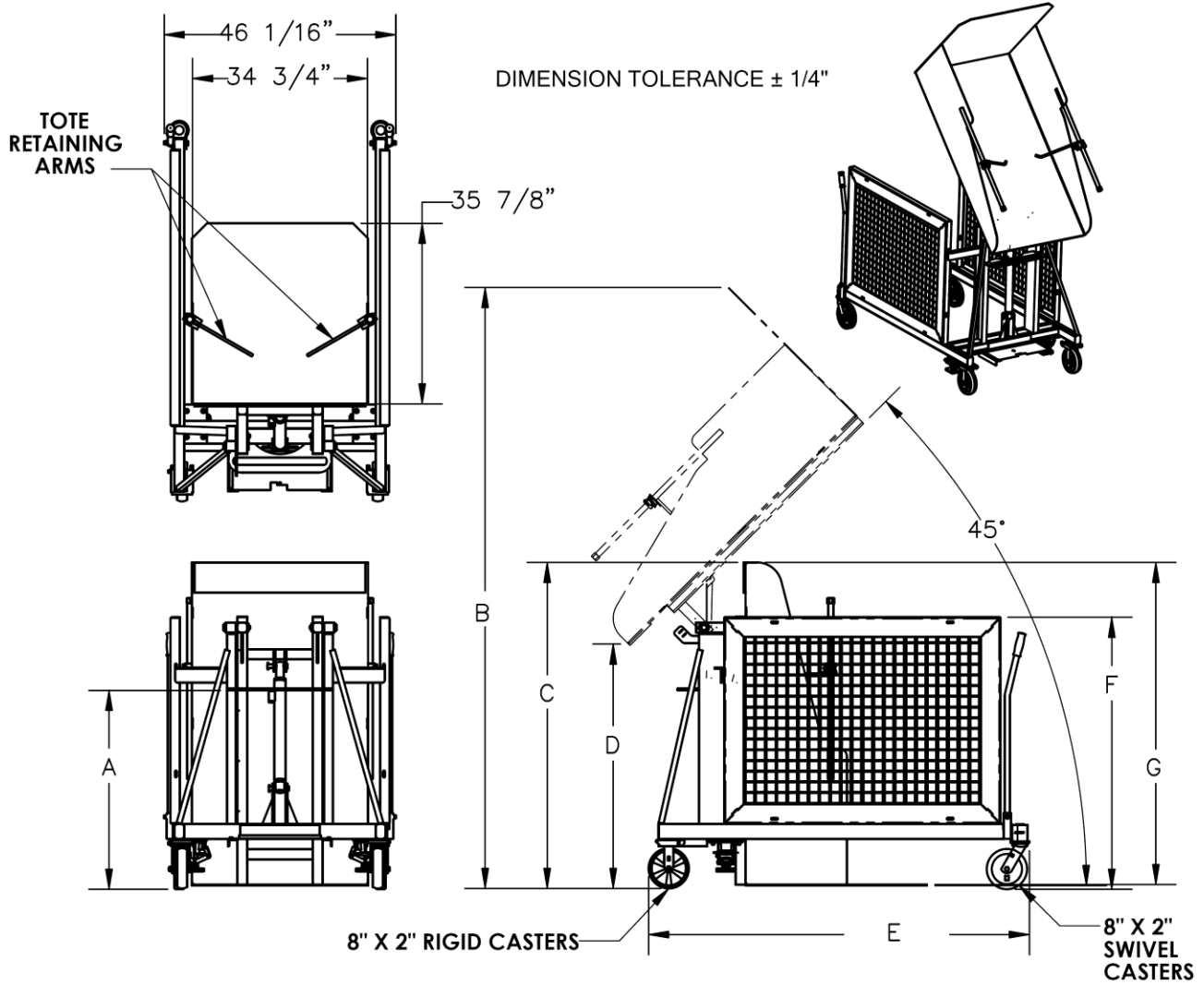

Model	A	B	C	D	E	F	G	Capacity	Net Weight
TCD-U-48-AC	39 ¹ / ₂ " 101 cm	119 ³ / ₈ " 304 cm	64 ³ / ₄ " 165 cm	48 ⁹ / ₁₆ " 124 cm	75 ⁵ / ₈ " 192 cm	54" 138 cm	64" 163 cm	400 lb. 182 kg	709 lb. 322 kg
TCD-U-48-DC	39 ¹ / ₂ " 101 cm	119 ³ / ₈ " 304 cm	64 ³ / ₄ " 165 cm	48 ⁹ / ₁₆ " 124 cm	75 ⁵ / ₈ " 192 cm	54" 138 cm	64" 163 cm	400 lb. 182 kg	709 lb. 322 kg
TCD-U-60-AC	41" 105 cm	140 ¹ / ₄ " 357 cm	78 ¹ / ₈ " 199 cm	59 ¹³ / ₁₆ " 152 cm	75 ⁵ / ₈ " 192 cm	65 ¹³ / ₁₆ " 168 cm	77 ⁵ / ₈ " 198 cm	400 lb. 182 kg	801 lb. 364 kg
TCD-U-60-DC	41" 105 cm	140 ¹ / ₄ " 357 cm	78 ¹ / ₈ " 199 cm	59 ¹³ / ₁₆ " 152 cm	75 ⁵ / ₈ " 192 cm	65 ¹³ / ₁₆ " 168 cm	77 ⁵ / ₈ " 198 cm	400 lb. 182 kg	801 lb. 364 kg
TCD-U-72-AC	53" 135 cm	160 ¹⁵ / ₁₆ " 409 cm	89 ¹⁵ / ₁₆ " 229 cm	71 ¹⁵ / ₁₆ " 183 cm	87 ⁵ / ₈ " 223 cm	77 ¹³ / ₁₆ " 198 cm	89 ⁵ / ₈ " 228 cm	400 lb. 182 kg	875 lb. 398 kg
TCD-U-72-DC	53" 135 cm	160 ¹⁵ / ₁₆ " 409 cm	89 ¹⁵ / ₁₆ " 229 cm	71 ¹⁵ / ₁₆ " 183 cm	87 ⁵ / ₈ " 223 cm	77 ¹³ / ₁₆ " 198 cm	89 ⁵ / ₈ " 228 cm	400 lb. 182 kg	875 lb. 398 kg

SIGNAL WORDS

SIGNAL WORDS appear in this manual to draw the reader's attention to important safety-related messages. The following are signal words used in this manual and their definitions.

⚠ DANGER

Identifies a hazardous situation which, if not avoided, **WILL** result in **DEATH** or **SERIOUS INJURY**. Use of this signal word is limited to the most extreme situations.

⚠ WARNING

Identifies a hazardous situation which, if not avoided, **COULD** result in **DEATH** or **SERIOUS INJURY**.

⚠ CAUTION

Indicates a hazardous situation which, if not avoided, **COULD** result in **MINOR** or **MODERATE** injury.

NOTICE

Identifies practices likely to result in product/property damage, such as operation that might damage the product.

SAFETY INSTRUCTIONS

Vestil strives to identify foreseeable hazards associated with the use of its products but cannot anticipate every possible situation. The end-user is responsible for safe operation and maintenance practices.

⚠ WARNING

Risks of serious personal injuries or death.

- Read and understand the entire manual before assembling, using, or servicing the device.
- Wear appropriate personal protective equipment (PPE), including safety shoes and gloves, during operation to protect against debris or pinch points.
- Ensure the area around the dumper is clear of personnel before operating to prevent accidental injuries.
- **ONLY** use the dumper to empty trash bins.
- Load the dumper according to the instructions in [USING THE DUMPER](#) on p. 15. TCD-M model dumpers must **ONLY** be used with Vestil Manufacturing Co. trash bins models TH-32, TH-64, and TH-95.
- Inspect the dumper before each use according to the inspection instructions on p. 16 & 17. **DO NOT** use the TCD unless it is in satisfactory condition. See [RECORD OF SATISFACTORY CONDITION, p. 16 & 17](#).
- Apply both floor locks **BEFORE** moving the chute. Floor locks should also be applied whenever the dumper is not in use.
- **DO NOT** move the dumper up or down slopes unless you can easily control the unit. If you must cross sloped ground, always position yourself uphill to the dumper.
- **DO NOT** stand beneath or travel under the dumper chute while it is elevated. **ALWAYS** stand to the side of the dumper whenever the chute is moving or elevated.
- **DO NOT** use this dumper **UNLESS** every label shown in the [LABELING DIAGRAM](#) on p. 19 is in place, undamaged, and easily readable.
- **DO NOT** exceed the capacity of the dumper. The capacity of each model appears in the [SPECIFICATIONS](#) tables on [pages 2 & 3](#) as well as on label 1153. The weight of the trash bin plus the weight of its contents must not exceed the capacity.
- **DO NOT** modify the dumper in any way without first obtaining written approval from Vestil. Unapproved modifications automatically void the [LIMITED WARRANTY](#) and might make the dumper unsafe to use.
- **DO NOT** use the dumper on sloped surfaces. **ONLY** use it on level, even surfaces.
- Before using the dumper, make sure that the chute will not contact overhead objects during use.
- In case of a hydraulic leak or mechanical failure, stop operation immediately and contact Vestil's [TECHNICAL SERVICE](#) department for assistance. See contact information on cover page.

NOTICE

This product must be properly maintained to function properly for as long as possible.

- Examine the dumper as instructed in [INSPECTING & MAINTAINING](#)... on [p. 16](#) (TCD-M) or [17](#) (TCD-U).
- Lubricate pivot points whenever necessary for the chute to rotate as quietly as possible.
- The dumper is designed for both indoor and outdoor use. However, it must be stored indoors when not in use and must not be used in the rain.

TCD-M-48-AC & -DC Exploded View and Bill of Materials (34-006-015)

AC power unit on page 14; DC power unit on page 13.

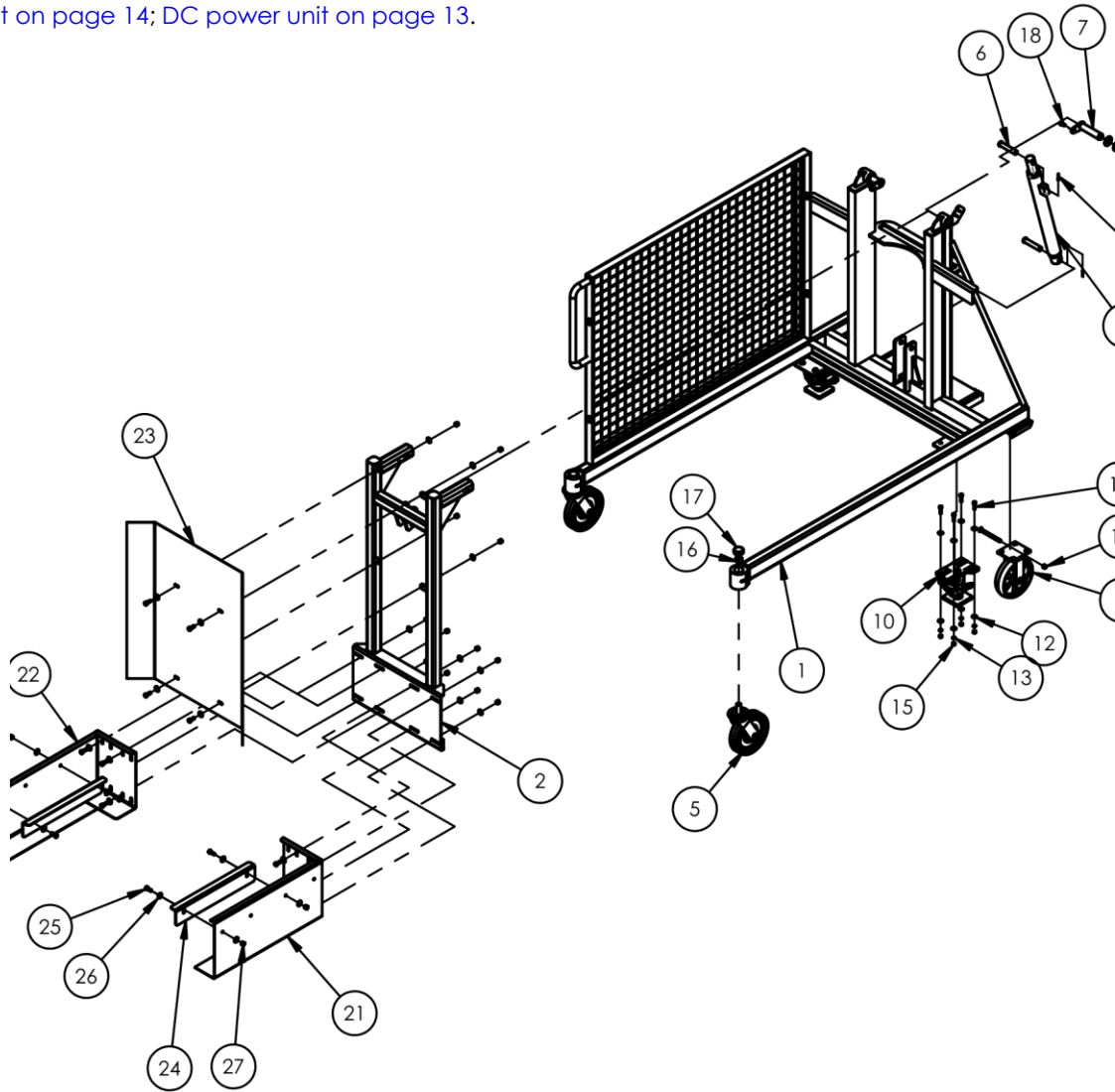

Item	Part no.	Description	Qty.	Item	Part no.	Description	Qty.
1	34-514-025	WELDMENT, FRAME	1	15	36104	HEX NUT, GRADE A, ZINC PLATED, 5/16-18	8
2	34-538-008	WELDMENT, CARRIAGE, WHEEL CRADLE	1	16	37275	3/4-10 TOP LOCK NUT Z PLATED GRADE C	2
3	99-021-904-001	CYLINDER, HYDRAULIC, Ø1 1/2" x 18", RAM STYLE	1	17	99-024-003	GUARD/COVER/ENDCAP/PLUG	2
4	16-132-233	CASTER, RIGID, GFN-8/2-R	2	18	32416	THREAD CUTTING SCREW, SLOTTED, TYPE F, ZINC PLATED, 5/16-18 X 3/4	2
5	16-132-181	STEM CASTER, SWIVEL, PHENOLIC	2	19	99-612-001	PIN, BULLDOG BOLT AND NUT ASSEMBLY	2
6	33-112-034	CLEVIS PIN, ZINC PLATED, Ø3/4" X 3 3/4" LG	2	20	65077	COTTER PIN, ZINC PLATED, 1/8" X 1-1/4"	2
7	34-612-004	WELDMENT, PIN RETAINER	2	21	34-516-008	WELDMENT, BRACKET, WHEEL CRADLE, LEFT	1
8	01-111-023	BUSHING, POLYGON 1 1/8 ID X 1 9/16 LG	2	22	34-516-009	WELDMENT, BRACKET, WHEEL CRADLE, RIGHT	1
9	33456	MACHINERY BUSHING, PLAIN FINISH, Ø1 1/8" X 10 GA	6	23	34-045-013	CHUTE, FORMED	1
10	16-001-190	FINAL ASSEMBLY W/O SHIPPING	2	24	34-016-046	BRACKET, FORMED	2
11	68021	EXTERNAL RETAINING RING, PHOSPHATE FINISH, 1-1/8"	2	25	11105	HEX BOLT, GRADE A, ZINC PLATED, 3/8"-16 X 1"	16
12	33006	FLAT WASHER, ZINC PLATED, USS, Ø5/16"	16	26	33008	FLAT WASHER, LOW CARBON, USS, ZINC PLATED, 3/8"	32
13	33620	LOCK WASHER, MEDIUM SPLIT, Ø5/16"	8	27	37024	NYLON INSERT LOCK NUT, GRADE 2, ZINC FINISH, 3/8"-16	16
14	11057	HEX BOLT, GRADE A, ZINC PLATED, 5/16-18X1.25	8				

TCD-M-60-AC & -DC and TCD-M-72-AC & -DC Exploded View & Bill of Materials (34-006-029)

AC power unit on page 14; DC power unit on page 13.

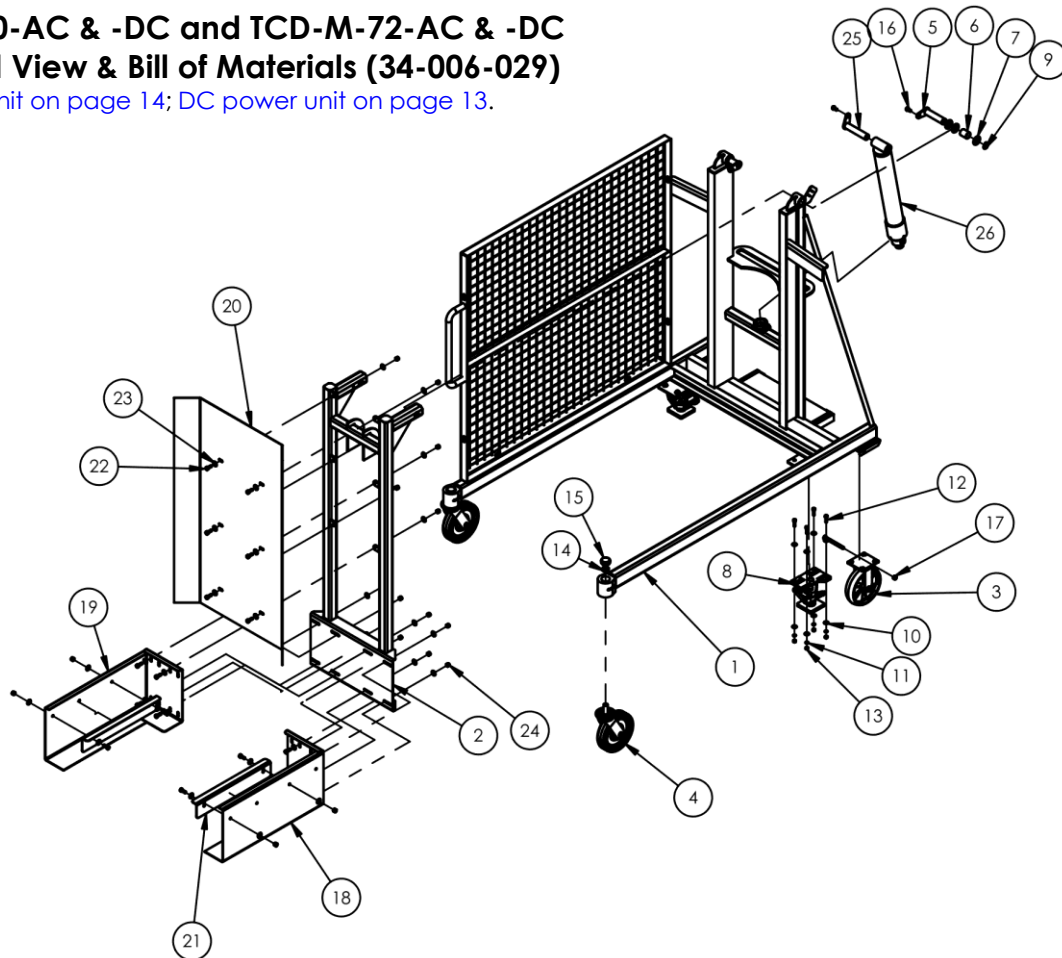

Item	Part no.	Description	Qty.
1	34-514-030	WELDMENT, FRAME	1
	34-514-036	TCD-M-60-AC & -DC TCD-M-72-AC & -DC	1
2	34-538-011	WELDMENT, CARRIAGE, WHEEL CRADLE	1
	34-538-010	TCD-M-60-AC & -DC TCD-M-72-AC & -DC	1
3	16-132-233	CASTER, RIGID, GFN-8/2-R	2
4	16-132-181	STEM CASTER, SWIVEL, PHENOLIC	2
5	34-612-004	WELDMENT, PIN RETAINER	2
6	01-111-023	BUSHING, POLYGON 1 1/8 ID X 1 9/16 LG	2
7	33456	MACHINERY BUSHING, PLAIN FINISH, Ø1 1/8" X 10 GA	6
8	16-001-190	FINAL ASSEMBLY W/O SHIPPING	2
9	68021	EXTERNAL RETAINING RING, PHOSPHATE FINISH, 1-1/8"	2
10	33006	FLAT WASHER,ZINC PLATED,USS, Ø5/16"	16
11	33620	LOCK WASHER, MEDIUM SPLIT, Ø5/16"	8
12	11057	HEX BOLT, GRADE A, ZINC PLATED, 5/16-18X1.25	8
13	36104	HEX NUT, GRADE A, ZINC PLATED, 5/16-18	8
14	37275	3/4-10 TOP LOCK NUT Z PLATED GRADE C	2
15	99-024-003	GUARD/COVER/ENDCAP/PLUG	2
16	32416	THREAD CUTTING SCREW, SLOTTED, TYPE F, ZINC PLATED, 5/16-18 X 3/4	3
17	99-612-001	PIN, BULLDOG BOLT AND NUT ASSEMBLY	1
18	34-516-008	WELDMENT, BRACKET, WHEEL CRADLE, LEFT	1
19	34-516-009	WELDMENT, BRACKET, WHEEL CRADLE, RIGHT	1
20	34-045-032	CHUTE, FORMED	1
21	34-016-046	BRACKET, FORMED	2
22	11105	TCD-M-60-AC & -DC: HEX BOLT, GRADE A, ZINC PLATED, 3/8"-16 X 1"	18
		TCD-M-72-AC & -DC: HEX BOLT, GRADE A, ZINC PLATED, 3/8"-16 X 1"	20
23	33008	TCD-M-60-AC & -DC: FLAT WASHER, LOW CARBON, USS, ZINC PLATED, 3/8"	36
		TCD-M-72-AC & -DC: FLAT WASHER, LOW CARBON, USS, ZINC PLATED, 3/8"	40
24	37024	TCD-M-60-AC & -DC: NYLON INSERT LOCK NUT, GRADE 2, ZINC FINISH, 3/8"-16	18
		TCD-M-72-AC & -DC: NYLON INSERT LOCK NUT, GRADE 2, ZINC FINISH, 3/8"-16	20
25	24-612-003	WELDMENT, CYLINDER PIN	1
26	99-021-909-001	CYLINDER, HYDRAULIC, Ø2 1/2" x 18" RAM STYLE	1

TCD-U-48-AC & -DC Exploded View and Bill of Materials (34-006-023)

AC power unit on page 14; DC power unit on page 13.

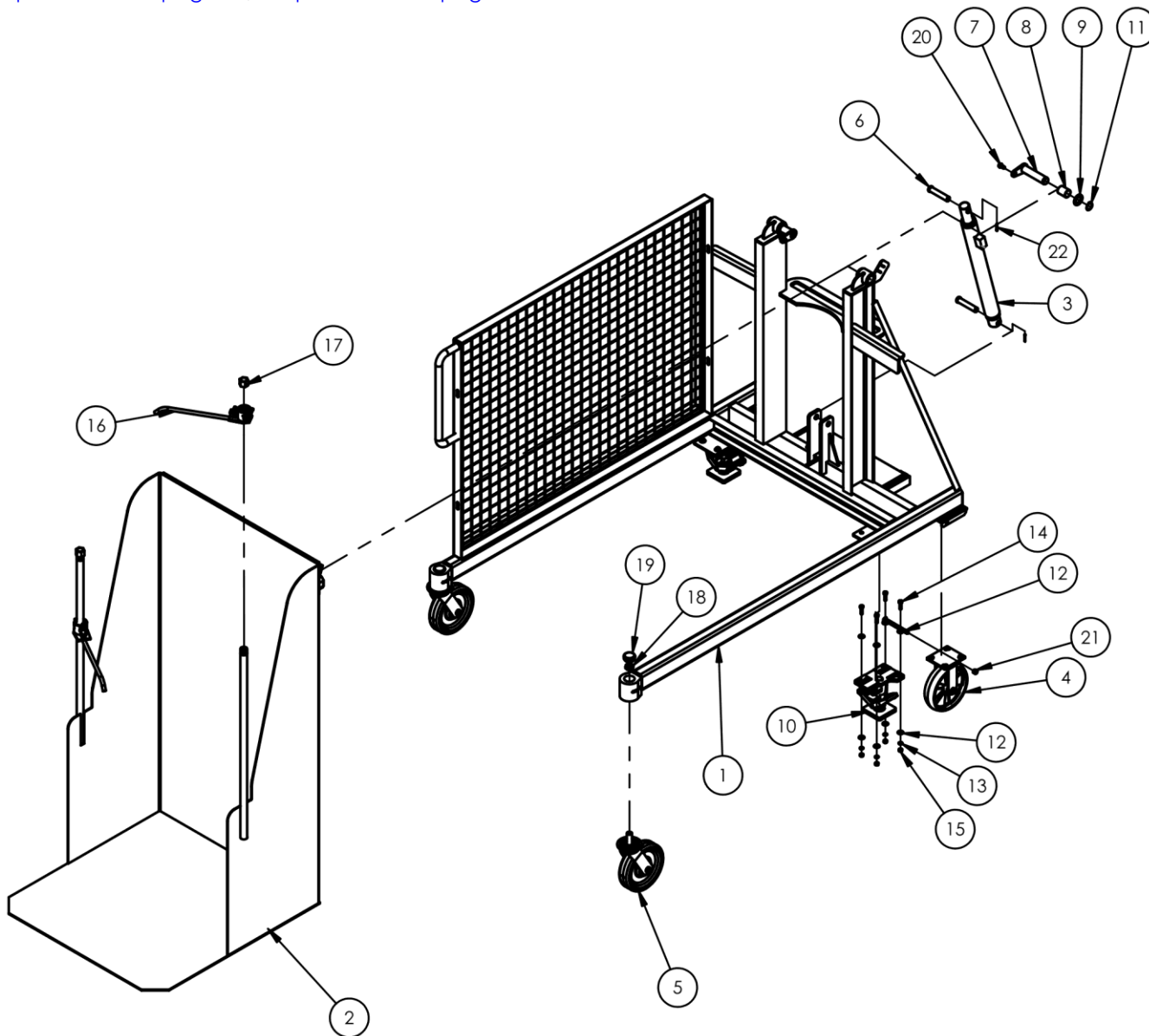

Item	Part no.	Description	Qty.	Item	Part no.	Description	Qty.
1	34-514-025	WELDMENT, FRAME	1	12	33006	FLAT WASHER,ZINC PLATED,USS, Ø5/16"	16
2	34-545-008	WELDMENT, CHUTE	1	13	33620	LOCK WASHER, MEDIUM SPLIT, Ø5/16"	8
3	99-021-904-001	CYLINDER, HYDRAULIC, Ø1 1/2" x 18", RAM STYLE	1	14	11057	HEX BOLT, GRADE A, ZINC PLATED, 5/16-18X1.25	8
4	16-132-233	CASTER, RIGID, GFN-8/2-R	2	15	36104	HEX NUT, GRADE A, ZINC PLATED, 5/16-18	8
5	16-132-181	STEM CASTER, SWIVEL, PHENOLIC	2	16	34-537-005	SUB-ASSEMBLY, PIPE CLAMP	2
6	33-112-034	CLEVIS PIN, ZINC PLATED, Ø3/4" X 3 3/4" LG	2	17	09-145-020	SPECIALTY HARDWARE, HEX PIPE CAP	2
7	34-612-004	WELDMENT, PIN RETAINER	2	18	37275	3/4-10 TOP LOCK NUT Z PLATED GRADE C	2
8	01-111-023	BUSHING, POLYGON 1 1/8 ID X 1 9/16 LG	2	19	99-024-003	GUARD/COVER/ENDCAP/PLUG	2
9	33456	MACHINERY BUSHING, PLAIN FINISH, Ø1 1/8" X 10 GA	6	20	32416	THREAD CUTTING SCREW, SLOTTED, TYPE F, ZINC PLATED, 5/16-18 X 3/4	2
10	16-001-190	FINAL ASSEMBLY W/O SHIPPING	2	21	99-612-001	PIN, BULLDOG BOLT AND NUT ASSEMBLY	2
11	68021	EXTERNAL RETAINING RING, PHOSPHATE FINISH, 1-1/8"	2	22	65077	COTTER PIN, ZINC PLATED, 1/8" X 1-1/4"	2

TCD-U-60-AC & -DC, TCD-U-72-AC & -DC Exploded View & Bill of Materials (34-006-033)

AC power unit on page 14; DC power unit on page 13.

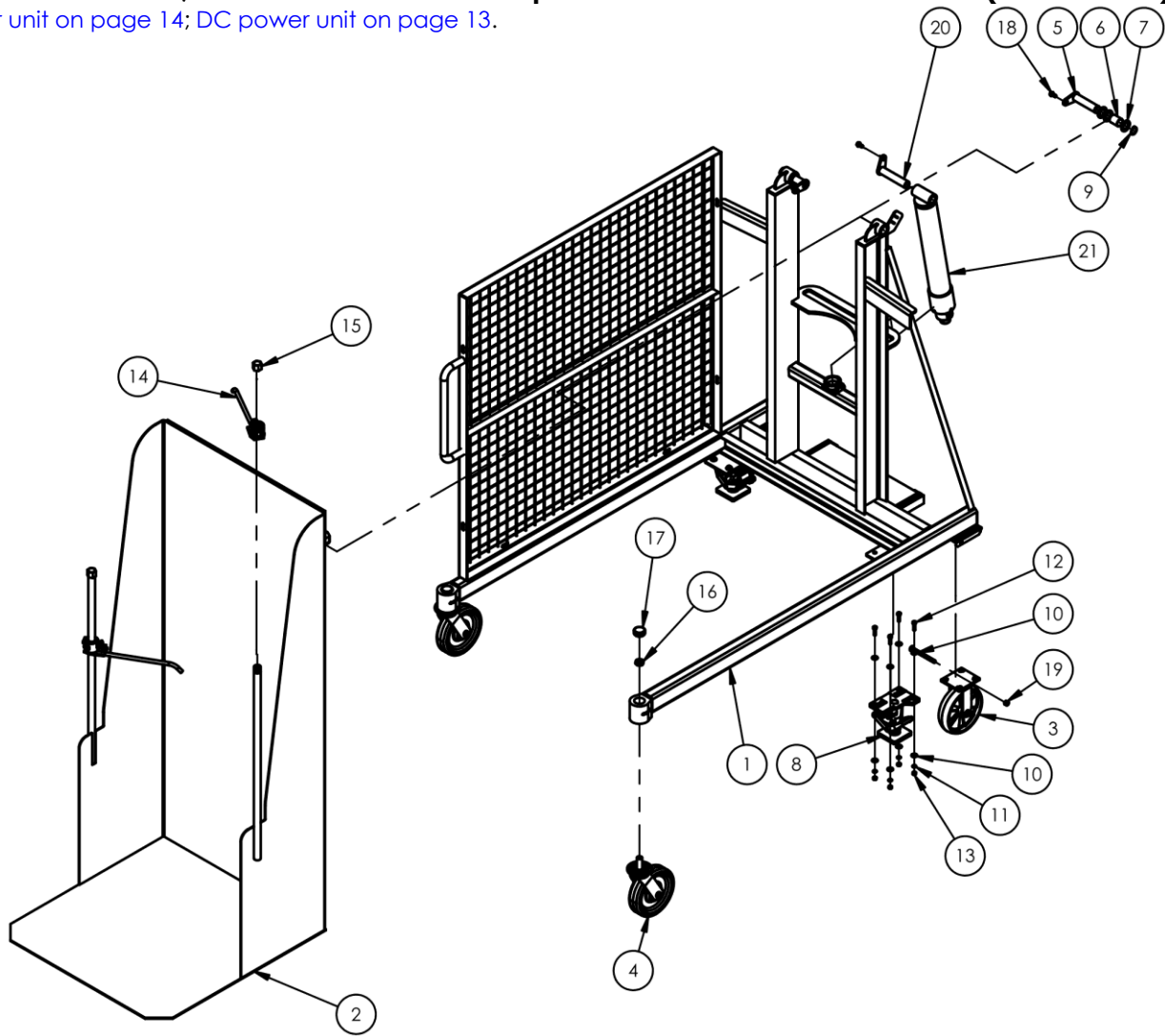

Item	Part no.	Description	Qty.	Item	Part no.	Description	Qty.
1	34-514-030 34-514-036	Weldment, frame TCD-U-60-AC & -DC TCD-U-72-AC & -DC	1 1	12	11057	HEX BOLT, GRADE A, ZINC PLATED, 5/16-18X1.25	8
2	34-545-015 34-545-016	Weldment, chute: TCD-U-60-AC & -DC TCD-U-72-AC & -DC	1	13	36104	HEX NUT, GRADE A, ZINC PLATED, 5/16-18	8
3	16-132-233	CASTER, RIGID, GFN-8/2-R	2	14	34-537-005	SUB-ASSEMBLY, PIPE CLAMP	2
4	16-132-181	STEM CASTER, SWIVEL, PHENOLIC	2	15	09-145-020	SPECIALTY HARDWARE, HEX PIPE CAP	2
5	34-612-004	WELDMENT, PIN RETAINER	2	16	37275	3/4-10 TOP LOCK NUT Z PLATED GRADE C	2
6	01-111-023	BUSHING, POLYGON 1 1/8 ID X 1 9/16 LG	2	17	99-024-003	GUARD/COVER/ENDCAP/PLUG	2
7	33456	MACHINERY BUSHING, PLAIN FINISH, Ø1 1/8" X 10 GA	6	18	32416	THREAD CUTTING SCREW, SLOTTED, TYPE F, ZINC PLATED, 5/16-18 X 3/4	3
8	16-001-190	FINAL ASSEMBLY W/O SHIPPING	2	19	99-612-001	PIN, BULLDOG BOLT AND NUT ASSEMBLY	2
9	68021	EXTERNAL RETAINING RING, PHOSPHATE FINISH, 1-1/8"	2	20	24-612-003	WELDMENT, CYLINDER PIN	1
10	33006	FLAT WASHER, ZINC PLATED, USS, Ø5/16"	16	21	99-021-909- 001	CYLINDER, HYDRAULIC, Ø2 1/2" x 18" RAM STYLE	1
11	33620	LOCK WASHER, MEDIUM SPLIT, Ø5/16"	8				

Power unit operation

NOTE: If your trash can dumper was manufactured on or after 12/01/2018, it is equipped with a 2nd generation modular power unit (MPU-GEN2). Pages 9-14 of this manual are replaced by separate MPU-GEN2 manuals.

Powered functions are controlled by a modular, electric-hydraulic power unit. Control signals from the power unit either extend or retract a hydraulic cylinder(s). Cylinder extension lifts the chute. Retraction lowers the chute, i.e. returns it to home position. An electric motor directly coupled to a gear pump pressurizes the hydraulic system. The hydraulic control components are housed inside a manifold bolted to the gear pump. All components are rated for 3,000psi working pressure.

Noteworthy components of the power unit include:

- Electric motor: the motor is either AC powered (wall socket) or DC powered (battery). AC-powered motors are available for either single-phase or three-phase operation. Every motor is dual-voltage capable.
- Gear pump: the pump shaft is directly coupled to the shaft of the electric motor. Several displacements are available to match the horsepower of the motor selected.
- Check valve: prevents backflow of fluid through the pump and to the reservoir. Because fluid can only flow in response to an electrical signal from the pendant controller, the chute can maintain any position between the raised and lowered configurations.
- Pressure relief valve: opens a path for fluid to flow back to the reservoir if fluid pressure exceeds 3,000psi.
- Lowering solenoid valve: electrically-operated cartridge valve with an integral screen to keep contaminants from entering the valve.
- Pressure compensated flow control spool: this device regulates the flow of hydraulic oil from the cylinder back to the reservoir. It is located beneath the lowering valve. This component allows the chute to lower at a predetermined constant rate regardless of the weight of the dumper and contents. Several sizes are available.
- Displacement style hydraulic cylinder(s): each cylinder includes a bleeder valve located at top end for removing air from the hydraulic system.
- Velocity fuse: a safety device installed in the hose port of each cylinder. If a hose is punctured while the unit is operating, the velocity fuse closes and the chute remains stationary until pressure is reapplied to the system.
- Hydraulic fluid: HO150 hydraulic fluid. To replenish the fluid, add anti-wear hydraulic fluid with a viscosity grade of 150 SUS at 100°F (ISO 32 @ 40°C) like AW-32 or Dexron transmission fluid.

Raising and lowering the chute

To raise/tilt the chute, hold the hand control and press the UP button. In response, the motor turns and rotates the gear pump. As the pump rotates, oil is drawn from the reservoir, passes through the suction filter, and enters the pump.

- The gear pump propels oil through the check valve to the lift cylinder(s).
- Releasing the UP button during operation immediately halts chute movement. Additionally, an electrical upper travel limit switch automatically turns off the motor when the chute reaches a 135° angle to the ground (horizontal).

To lower the chute, press the DOWN button.

- Lowering valve opens which bypasses the check valve and allows oil in the cylinder(s) to flow to the reservoir (through return hoses). Oil flow to the reservoir is regulated by the pressure compensated flow control valve. By regulating the volume of oil that can flow through the spool, the speed at which the chute lowers is kept constant.
- Releasing the DOWN button during operation causes all chute movement to stop. The chute will remain in the same position until you press either button on the pendant controller.

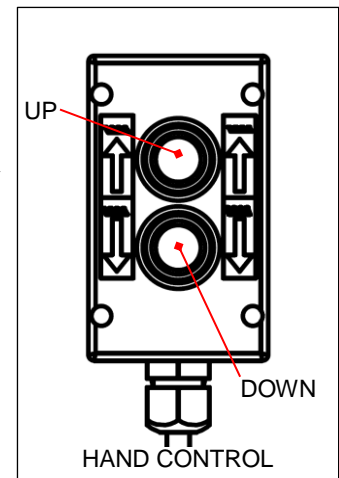

Cleaning lowering solenoid valve

If the chute slowly loses elevation without pressing the DOWN button, lower the chute completely. Then, remove, inspect, and clean the lowering cartridge valve in the following manner:

1. Lower the chute completely and turn off electrical power to the unit. If your dumper is AC powered, unplug the electrical cord from the wall socket. If your unit is DC powered (battery), turn the key switch to the OFF position.
2. Unload the dumper.
3. Remove the nut that fastens the solenoid coil to the valve stem; then remove the coil and unscrew the valve from the manifold.
4. Inspect the valve for blockage.
5. Inspect o-rings and back-up washers for cuts, tears, etc.
6. Submerge the valve in mineral spirits or kerosene.
7. Use a thin tool, such as a small screwdriver or a hex wrench, to push the poppet in and out several times from the bottom end of the valve. The valve should move freely, about 1/16" between the closed and open positions. If the poppet sticks, the valve stem might be bent. Replace the poppet if it doesn't free up after cleaning.
8. Remove mineral oil from the valve with compressed air.
9. Move the poppet in and out.
10. Inspect the bottom of the valve cavity in the manifold for foreign matter.
11. With the thin tool, press the middle of the flow control spool, which is located in the bottom of the cavity. It should move in-and-out smoothly.

12. Reinstall the valve in the manifold and tighten it to 20 lb-ft of torque.

Bleeding air from hydraulic system

If the chute lowers extremely slowly or does not lower, air in the cylinder(s) might be the culprit. Air in the hydraulic system causes the velocity fuse to close, which traps oil in the cylinder(s). To overcome this problem, air must be “bled” from the system.

- Completely lower the chute and unload it;
- Locate the bleeder valve located at the top of the cylinder(s) (it looks like a grease zerk). Hold a rag over the valve and open it about a half turn with a 1/4" or 5/16" wrench. Oil and air will sputter from the valve. Jog the motor by pressing the UP button for just a second. If air continues to escape from the bleeder valve, jog the motor several more times. Wait at least 5 seconds between successive jogs.
- Close the valve once air no longer is heard or seen bubbling out of the valve. At this point, just a clear stream of oil is seen flowing from the bleeder valve. Close the valve.
- Remove the cover from the modular power unit and check the oil level in the reservoir. If the surface of the oil is lower than 1 to 1½ in. below the fill hole, then add oil until it is between 1 and 1½ inches of the fill hole. Add only non-synthetic anti-wear hydraulic fluid with a viscosity grade of 150 SUS at 100°F (ISO 32 @ 40°C) like AW-32 or Dexron transmission fluid.

Hydraulic circuit diagram

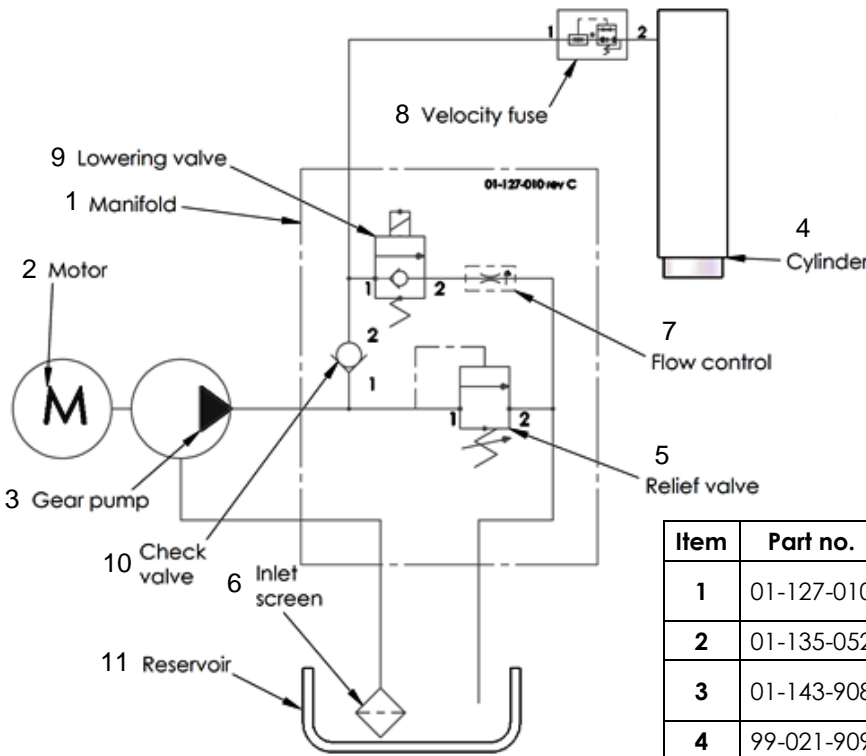

Item	Part no.	Description	Quantity
1	01-127-010	Manifold, aluminum, w/o valves	1
2	01-135-052	2HP, 3-phase, 1725 RPM motor	1
3	01-143-908	Gear pump, 0.153 displacement	1
4	99-021-909	Cylinder, 2½" x 18" ram style	2
5	99-153-006	Relief valve, 210 bar, size 08	1
6	99-031-029	Inlet screen, 100 mesh 2" pancake	1
7	99-153-038	Flow control, PC, 7/16" - 20, 2gpm	1
8	01-531-001	Velocity fuse, adjustable, brass	2
9	99-153-015	Valve, cartridge, NC, no coil, w/ nut	1
10	99-153-011	Check valve, size 08	1
11	99-023-002	Reservoir, L-shaped, 1.16 gal., 1.0 gal. nominal	1

12VDC Electrical Circuit Diagram (99124026 Rev. E)

*See NOTE in [TABLE OF CONTENTS](#) on cover page.

In this diagram, all components are represented with the chute in "home" location.

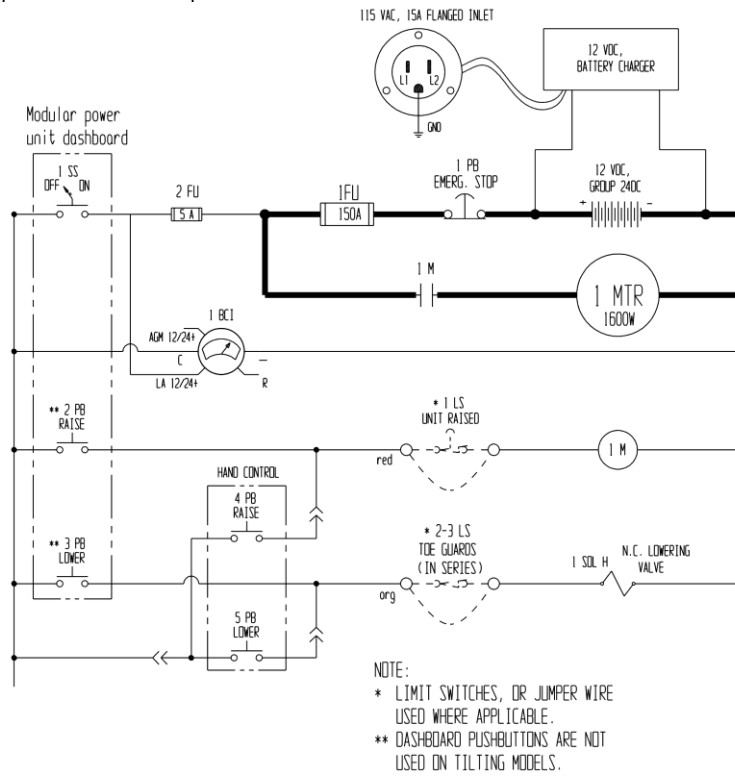

115VAC Electrical Circuit Diagram (99124026 Rev. E)

*See NOTE in [TABLE OF CONTENTS](#) on cover page.

In this diagram, all components are represented with the chute in HOME position. Overcurrent and short-circuit protection should be provided by the end user in accordance with recommendations and requirements in NEC (NFPA 70) and local codes.

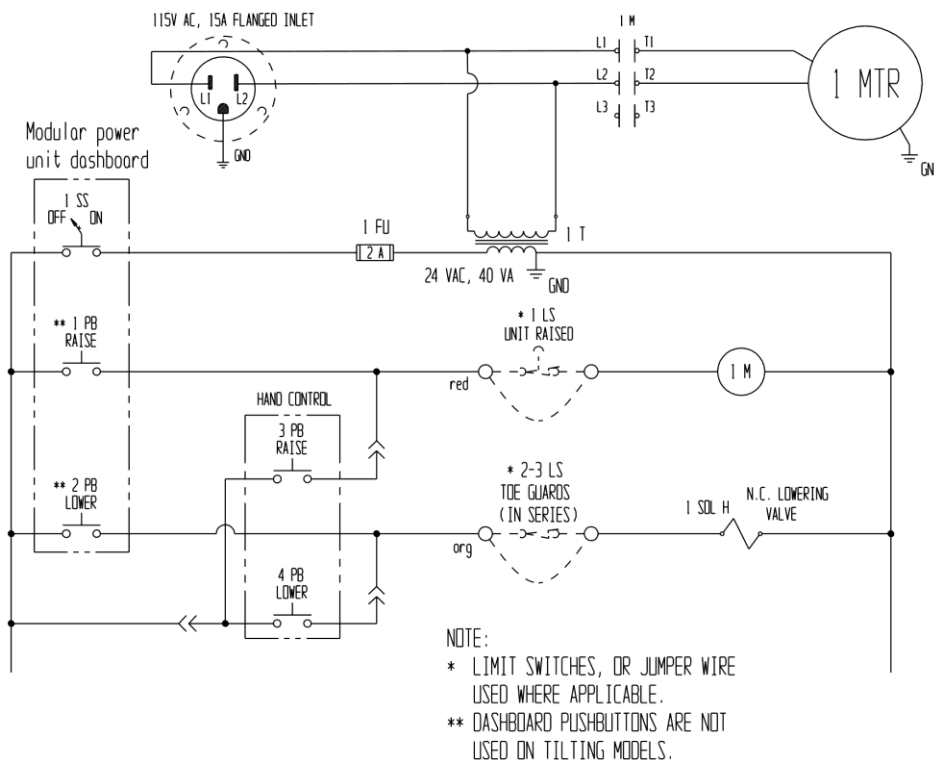

208-230VAC, 1-phase, electrical circuit diagram (99124033 Rev. A)

*See NOTE in [TABLE OF CONTENTS](#) on cover page.

In this diagram, all components are represented with the chute in lowered position. Overcurrent and short-circuit protection should be provided by the end user in accordance with recommendations and requirements in NEC (NFPA 70) and local codes.

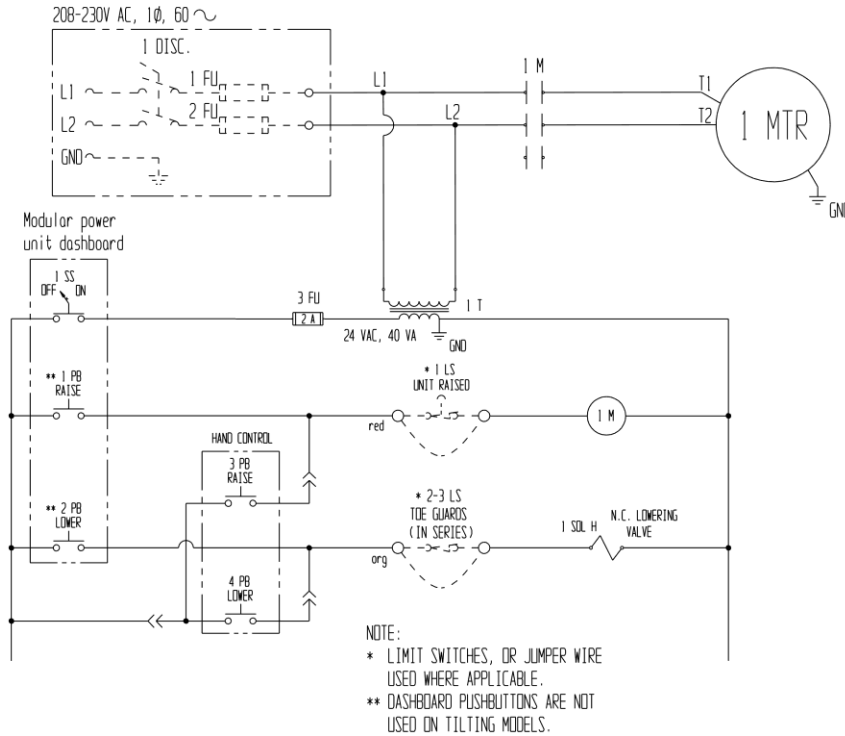

3-phase electrical circuit diagram (99124032 Rev. A)

*See NOTE in [TABLE OF CONTENTS](#) on cover page.

In this diagram, all components are represented with the chute in lowered position. Overcurrent and short-circuit protection should be provided by the end user in accordance with recommendations and requirements in NEC (NFPA 70) and local codes.

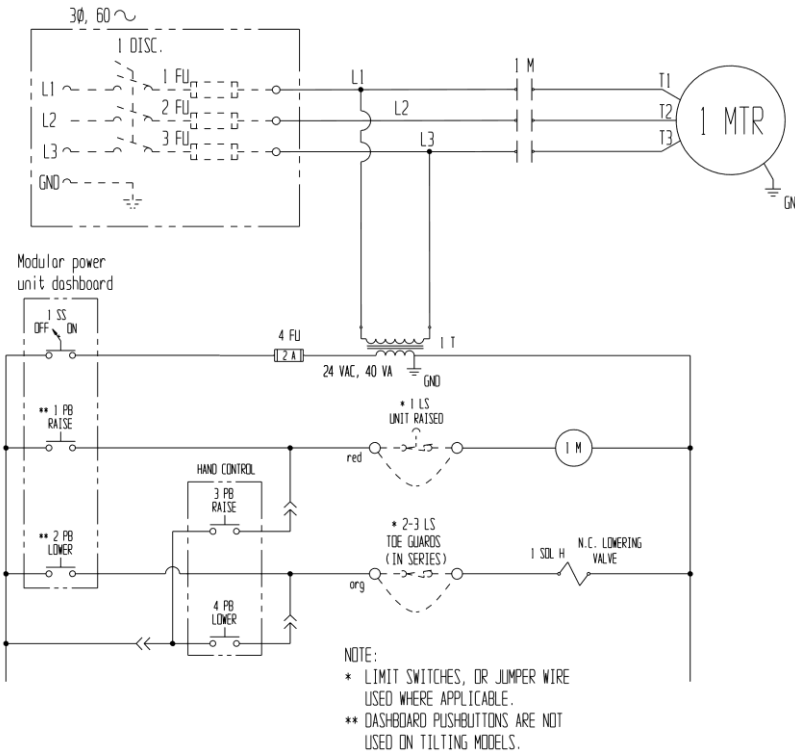

DC Modular Power Unit Exploded View and Bill of Materials

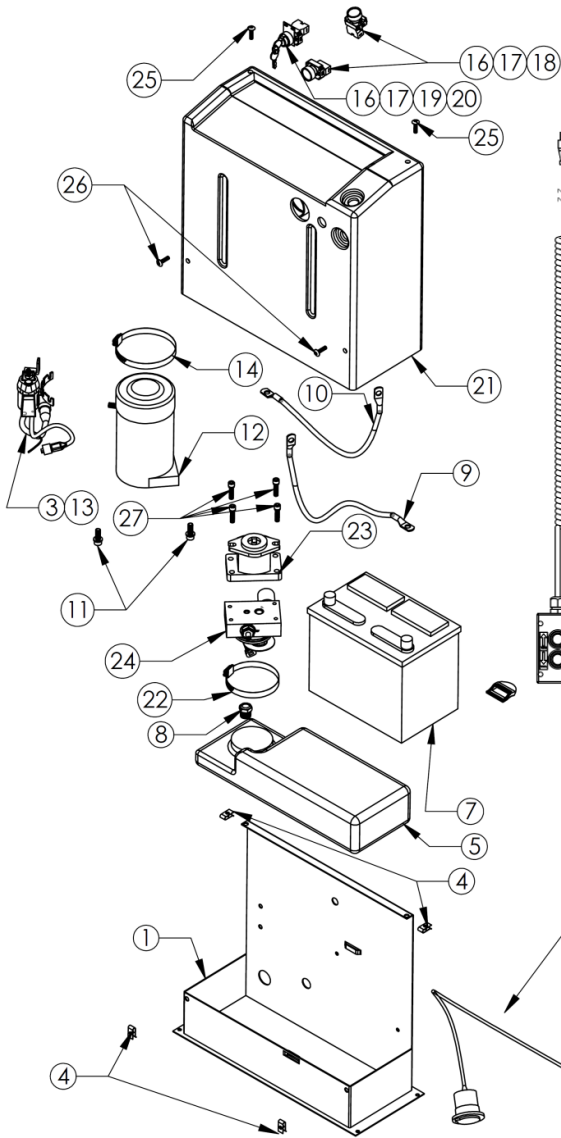

Manifold assembly (24) exploded parts diagram and bill of materials

Item	Part no.	Description	Qty.
31	568-015-BN70	O-ring, large	1
32	568-011-BN70	O-ring, small	1
33	99-153-058	Valve, solenoid, zero leak	1
34	99-034-010	Coil w/ weathertight plug	1
35	99-153-006	Valve, pressure relief	1
36	568-334-BN70	O-ring, 2 ⁵ / ₈ "x3"x3 ³ / ₁₆ "	1
37	99-031-029	Screen, inlet, 1 ³ / ₄ " diameter	1
38	99-153-038	Valve, pressure compensated flow control	1
39	01-127-010	Manifold, LHL standard	1
40	99-116-033	Fitting, #6 JIC - #6 O-ring, 90 deg.	1
41	99-153-011	3/8"-16x1" socket head bolt	1

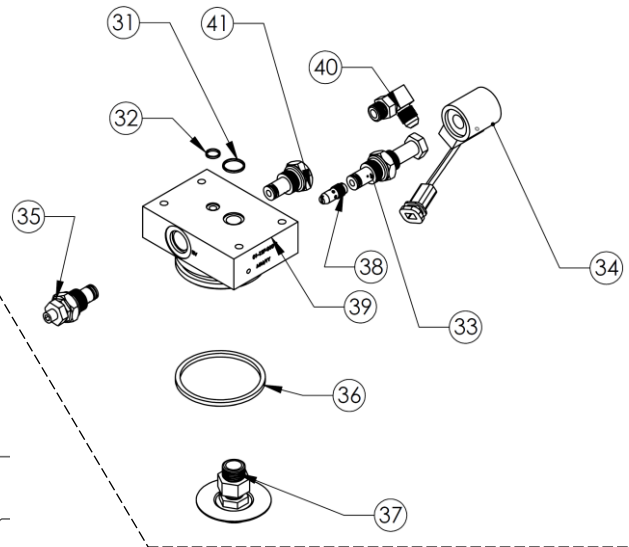

Item	Part no.	Description	Quantity	Item	Part no.	Description	Quantity
1	99-016-933	Base	1	16	Zb2bz009	Contact block base	2
2	21-034-008	Battery charger	1	17	Zb2be101	Contact block, N.O.	2
3	99-533-008	Adaptor, hand control	1	18	Zb2ba2c	Operator, black, flush, non-illuminated	2
4	37927	Tinnerman clip	4	21	99-024-010	Cover, plastic	1
5	99-023-001	Reservoir	1	22	HS52	Clamp, worm gear hose	1
6	99-034-013	Battery strap	1	23	01-143-906-002	Pump, hydraulic gear	1
7	99-139-003	Battery	1	*24	01-627-010	Manifold assembly	1
8	01-116-003	Breather, vent, brass fitting	1	25	29201	Screw, machine, 1/4"-20x1 ³ / ₄ "	2
9	15-533-013	23" black #4 AWG battery cable	1	26	29185	Screw, machine, 1/4"-20x1"	2
10	15-533-014	23" black #4 AWG battery cable	1	27	23255 33687	Bolt, socket head, 5/16"-18x1" Washer, lock, 5/16"	4 4
11	23305 33688 33008	3/8"-16x1" socket head bolt 3/8" lock washer 3/8" flat washer	2 2 2	28	152400-03	Molded cord, charger connect	1
12	99-135-011	Motor	1	29	21-034-025	Flanged inlet w/ locking ring	1
13	15-022-004	Relay, start solenoid	1	30	3MTST3540	1" hook & loop strip	10"
14	HS64	Clamp, worm gear hose	1	42	99-522-027	Hand control, 2-button	1
15	BG-12V	Gauge, battery, charge indicator	1				

AC modular power unit exploded view and bill of materials

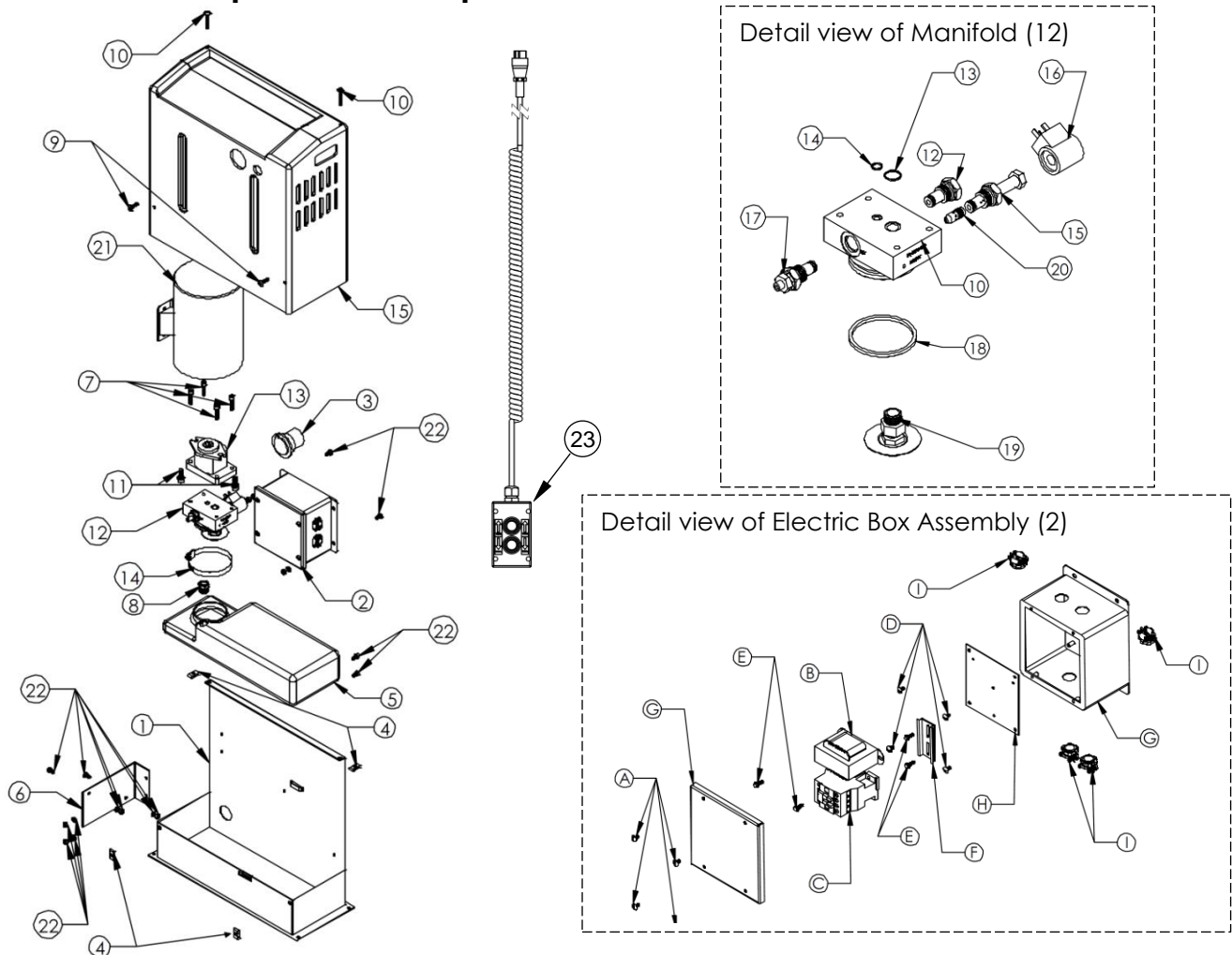

Item	Part no.	Description	Qty.	Item	Part no.	Description	Qty.
1	99-016-933	MPU base bracket	1	11	23305 33688 33008	3/8" – 16 x 1" socket head bolt 3/8" lock washer 3/8" flat washer	2 2 2
2		Electric box assembly	1	12	01-627-010	LHL manifold assembly	1
3	21-034-005	Connector, flanged inlet plug	1	13	01-143-906-002	Hydraulic gear pump	1
4	37927	U nut	4	14	99-145-061	Worm gear hose clamp	1
5	99-023-001	Reservoir	1	15	99-024-029	Plastic cover (gray)	1
6		Motor brace	1	16	ZB2BZ009	Contact block base	2
7	23255 33687	5/16" – 18 x 1" socket head bolt 5/16" lock washer	4 4	17	ZB2BE101	Contact block, n.o.	2
8	01-116-003	Breather, vent, brass fitting	1	18	ZB2BA2C	Operator, black, flush, non-illuminated	2
9	29185	1/4" – 20 x 1" Phillips head truss machine screw	2	21	99-135-003	Motor, 3/4 HP	1
10	29201	1/4" – 20 x 1 3/4" machine screw	2	22	11005 33004 33618 36102	1/4" – 20 - 1" hex head bolt 1/4" flat washer 1/4" lock washer 1/4" – 20 hex nut	6 6 6 6
				23	99-522-027	Hand control, 2-button	1
A	71616	10-32 x 5/8" truss head machine screw	4	F	Tb-track	39" rail, din, aluminum	3"
B	01-129-001	Control transformer	1	G	01-029-006	Junction box with screw lid	1
C	132560	Contactora, motor, UL Listed	1	H	Ab66jp	Plate, enclosure	1
D	27531	10-32 x 1/4" z-plated machine screw	4	I	C500	Connector, clamp, NM, Romex	4
E	32028	#8 – 18 x 1/2" self-tapping screw	4				

Using the trash can dumper

NOTE: Only use TCD-M dumpers with Vestil model [TH-32](#), [TH-64](#) and [TH-95](#) trash bins.

Step 1: Move the trash can dumper (TCD) next to the dumpster or other large trash receptacle. Move the TCD by grasping the handles and pushing it in the intended direction. Position the TCD as shown in the diagram and apply both floor locks. Floor locks are surrounded by a red dotted square in the diagram.

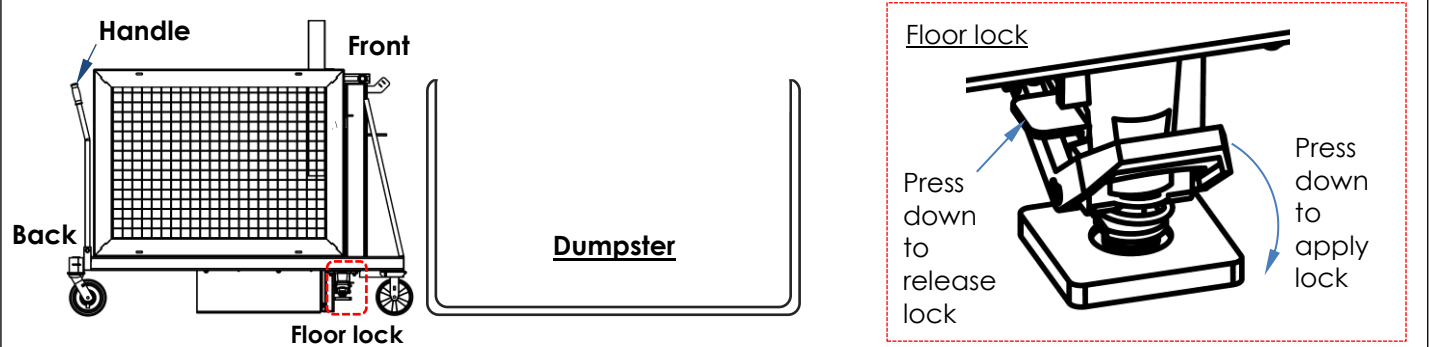

Step 2: [TCD-M units] Configure the wheel cradles for the trash bin that will be used with the dumper. Attach the wheel cradles to the mounting plate as shown in the appropriate diagram.

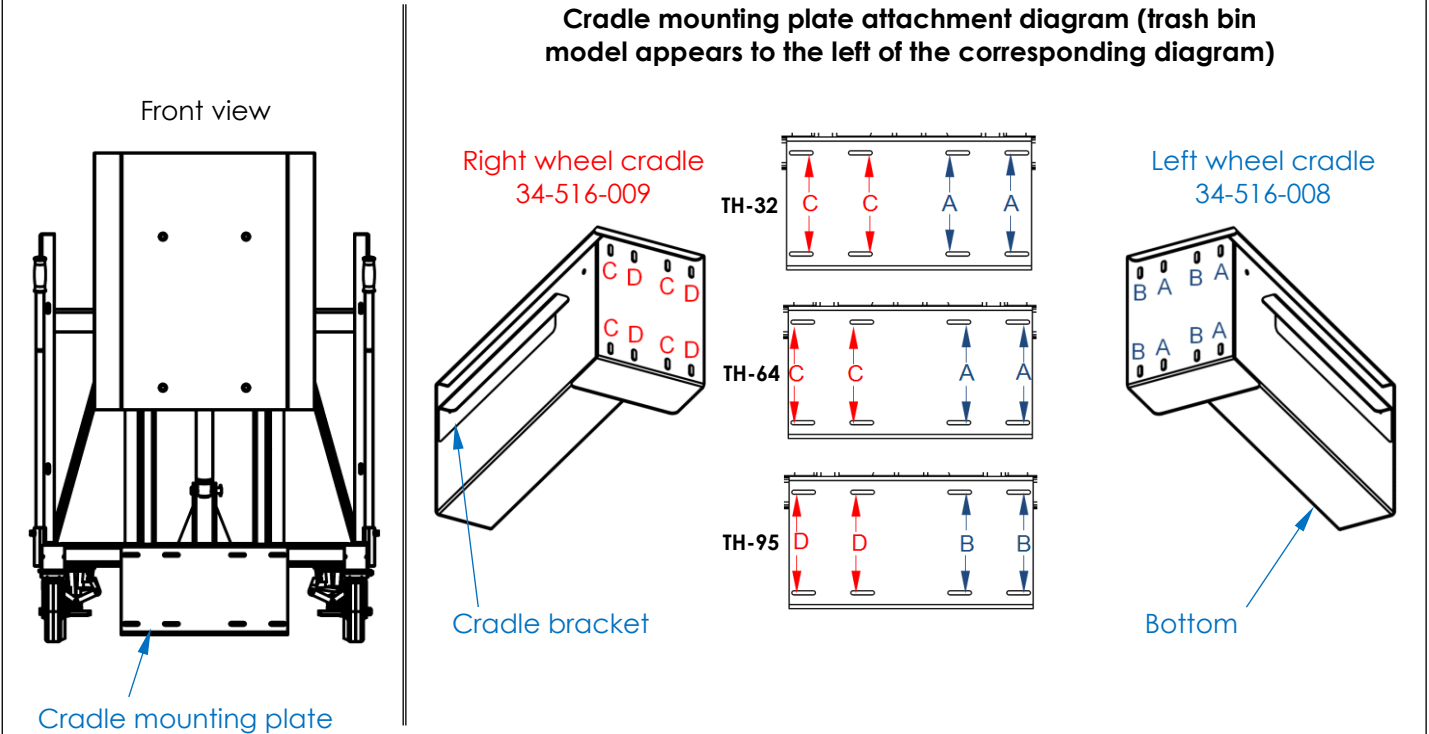

Step 3 [TCD-U units only]: Push your trash bin into the chute. The front of the bin should rest against the back of the chute. Open the lid. Slide the bin retainers along the retainer rails into firm contact with the top of the bin. To slide a retainer down a rail, simply press on the retainer. To slide a retainer up a rail, release the clamp and then move the retainer.

Step 3 [TCD-M units only]: Push the trash bin between the wheel cradles. Wheels will fit between the cradle brackets and the bottom flanges of the cradles. See step 2.

Step 4: Stand to the side of the dumper. Raise/tilt the chute by pressing the UP button on the hand control (see p. 9). Press the button until the power unit stops. The power unit stops when the chute is fully tilted. When the trash bin is empty, lower the chute by pressing the DOWN button on the hand control. The power unit will automatically stop when the chute is completely lowered.

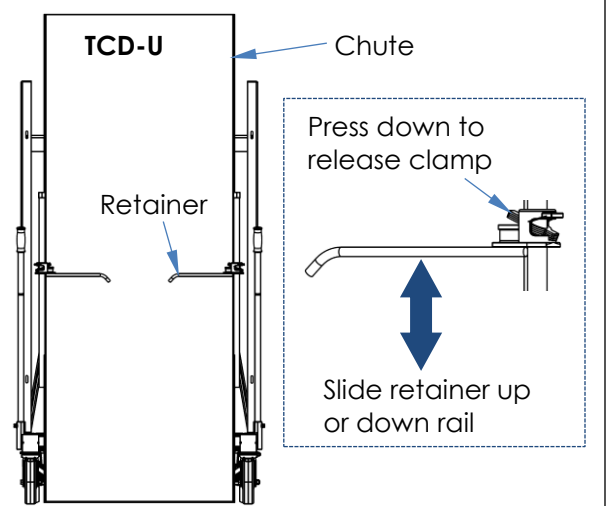

Record of Satisfactory Condition – TCD-M [Refer to *EXPLODED VIEW* on either p. 5 or p. 6.]

After receiving the product and before putting it into service, make a record of its appearance and functions. Photograph the modular power unit, frame, chute, retainers and rails, handles, casters, safety guards, and fasteners (bolts, nuts, etc.). Take close range photographs of all labels. Cycle the chute all the way up and back down. Record observations about how the cylinder extends and retracts, how the chute rotates, and all sounds heard. Collate the photographs and written descriptions into a single. Mark the file appropriately to identify it. This record establishes satisfactory condition. During future inspections, compare your observations to this record to determine whether the machine is in satisfactory condition. *Do not use the dumper unless it is in satisfactory condition.* Purely cosmetic changes, like damaged surface coating (paint or powdercoat) are not changes from satisfactory condition. However, touchup paint should be applied as soon as damage occurs.

Inspections – TCD-M series dumpers

Before each use, inspect the listed components:

- Modular power unit, pendant controller, wiring: Remove the cover. Examine wires for frays, cuts, tears, etc. Inspect the oil reservoir, hoses, and fittings for leaks, kinks, punctures (DC-powered units) Check battery charge status. Recharge the battery, if necessary.
- Hydraulic system: Check the hoses for pinches, kinks, punctures, and leaks. Check connections with the cylinder for leaks, etc.
- Wheel cradles: Examine the cradles and cradle brackets for damage such as bends and cracks. Each cradle should be solidly fastened to the chute frame. Tighten loose bolts and nuts.
- Frame: Check the welds and overall condition of the safety guards, pivot points, cylinder brackets (on the frame and the chute), handles, and chute. Look for cracks, damaged welds, severe wear, and corrosion.
- Cylinder and limit switches: Cycle the chute through a complete dumping sequence (fully rotated and back to the ground). When the chute reaches maximum dumping height, the power unit should stop running. Lower the chute. The piston should extend and retract smoothly without binding or jerking. Listen for unusual sounds that might indicate binding during operation. Watch for unusual movement. If you observe any unusual sound or movement, do not use the dumper until it has been restored to normal operating condition.

At least once per month, inspect the dumper as follows:

- Oil level: remove the cover from the modular power unit. Then, fully raise the chute (to the 45° “dumping position”) and observe the level of oil in the reservoir. The surface of the oil should be 1 to 1½ inches below the fill hole. If oil is needed, add oil as specified below in “Oil specifications”.
- Casters: confirm that all 4 casters roll smoothly. The front casters should swivel freely through 360°. The rear casters are rigid, i.e. do not swivel. Confirm that the rear casters are secured in their respective receivers.
- Fasteners: check each fastener connection (nuts, bolts, pins, etc.). Tighten loose connections. Replace all damaged hardware.
- Hydraulic hoses and electrical wires: check each wire and hose for damage (frays, kinks etc.).
- Floor locks: apply and disengage the floor locks (one on each side of the frame). Confirm normal operation.
- Labels: labels should be easily readable, undamaged, and located as shown in the “Labeling diagram” on p. 19.

Oil specifications: At least once per year change the hydraulic oil. Change the oil as soon as it becomes gritty or looks milky (indicating that water is present). With the chute in the fully lowered position, drain the oil and replace it with either Dexron transmission fluid or anti-wear hydraulic oil viscosity grade 150 SUS at 100°F (ISO 32 cSt at 40°C).

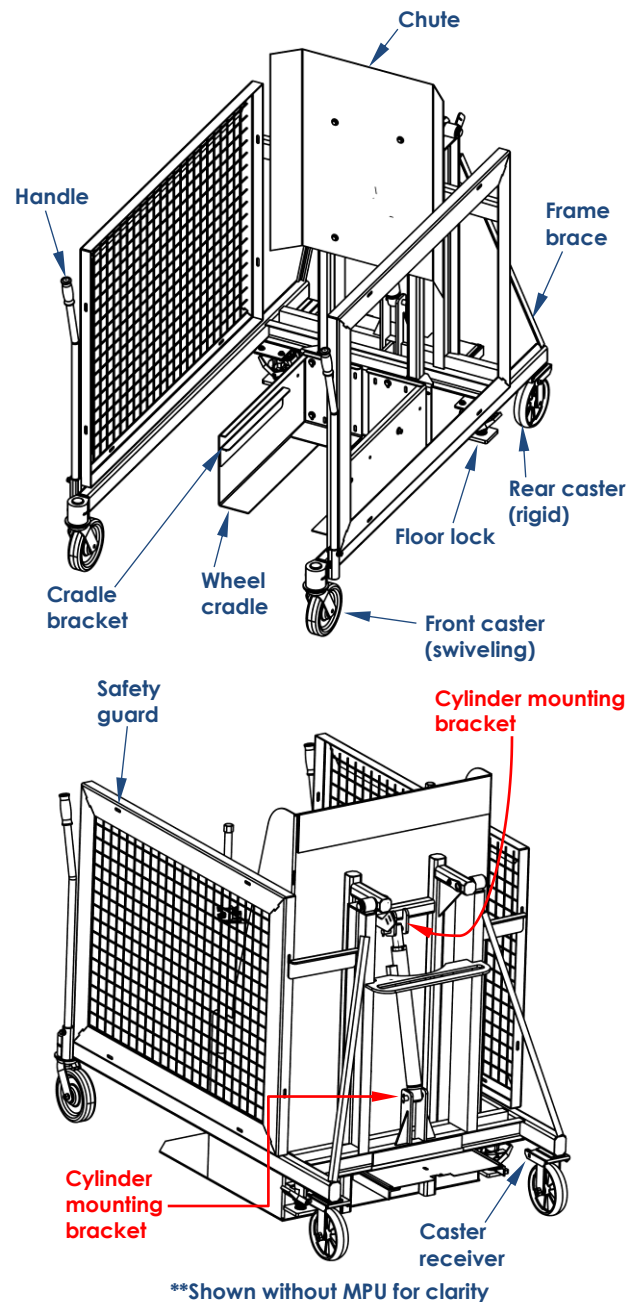

Record of Satisfactory Condition – TCD-U [Refer to *EXPLODED VIEW* on either p. 7 or p. 8.]

Before putting the machine into service, make a record of its appearance and functions. Photograph the modular power unit, frame, chute, retainers and rails, handles, casters, safety guards, and fasteners (bolts, nuts, etc.). Take close range photographs of all labels. Cycle the chute all the way up and back down. Record observations about how the cylinder extends and retracts, how the chute rotates, and all sounds heard. Collate the photographs and written descriptions into a single file. Mark the file appropriately to identify it. This record establishes satisfactory condition. During future inspections, compare your observations to this record to determine whether the machine is in satisfactory condition. *Do not use the dumper unless it is in satisfactory condition.* Purely cosmetic changes, like damaged surface coating (paint or powdercoat) are not changes from satisfactory condition. However, touchup paint should be applied as soon as damage occurs.

Inspections – TCD-U series dumpers

Before each use, inspect the listed components:

- Modular power unit, pendant controller, wiring: Remove the cover. Examine wires for frays, cuts, tears, etc. Inspect the oil reservoir, hoses, and fittings for leaks, kinks, punctures (DC-powered units) Check battery charge status. Recharge the battery, if necessary.
- Hydraulic system: Check the hoses for pinches, kinks, punctures, and leaks. Check connections for leaks, etc.
- Bin retainers and clamp rails: Examine the retainers for damage such as bends, cracks, and looseness. Each clamp should maintain position along the rail (i.e. should not slide). Rails should be straight and rigidly welded to the chute
- Frame: Check the welds and overall condition of the safety guards, pivot points, cylinder brackets (on the frame and the chute), handles, and chute. Look for cracks, damaged welds, severe wear, and corrosion.
- Cylinder and limit switches: Cycle the chute through a complete dumping sequence (fully rotated and back to the ground). When the chute reaches maximum dumping height, the power unit should stop running. Lower the chute. The piston should extend and retract smoothly without binding or jerking. Listen for unusual sounds that might indicate binding during operation. Watch for unusual movement. If you observe any unusual sound or movement, do not use the dumper until it has been restored to normal operating condition.

At least once per month, inspect the dumper as follows:

- Oil level: remove the cover from the modular power unit. Then, fully raise the chute (to the 45° "dumping position") and observe the level of oil in the reservoir. The surface of the oil should be 1 to 1½ inches below the fill port. If oil is needed, add oil as specified below in "Oil specifications".
- Casters: confirm that all 4 casters roll smoothly. The front casters should swivel freely through 360°. The rear casters are rigid, i.e. do not swivel. Confirm that the rear casters are secured in their respective receivers.
- Fasteners: check each fastener connection (nuts, bolts, pins, etc.). Tighten loose connections. Replace damaged hardware.
- Hydraulic hoses and electrical wires: check each wire and hose for damage (frays, kinks etc.).
- Floor locks: verify that both floor locks operate normally (one on either side of the frame).
- Labels: labels should be easily readable, undamaged, and be located as shown in the "Labeling diagram" on p. 19.

Oil specifications: Change the hydraulic oil *at least once per year*. Change the oil as soon as it becomes gritty or looks milky (indicating that water is present). With the chute in the fully lowered position, drain the oil and replace it with either Dexron transmission fluid or anti-wear hydraulic oil viscosity grade 150 SUS at 100°F (ISO 32 cSt at 40°C).

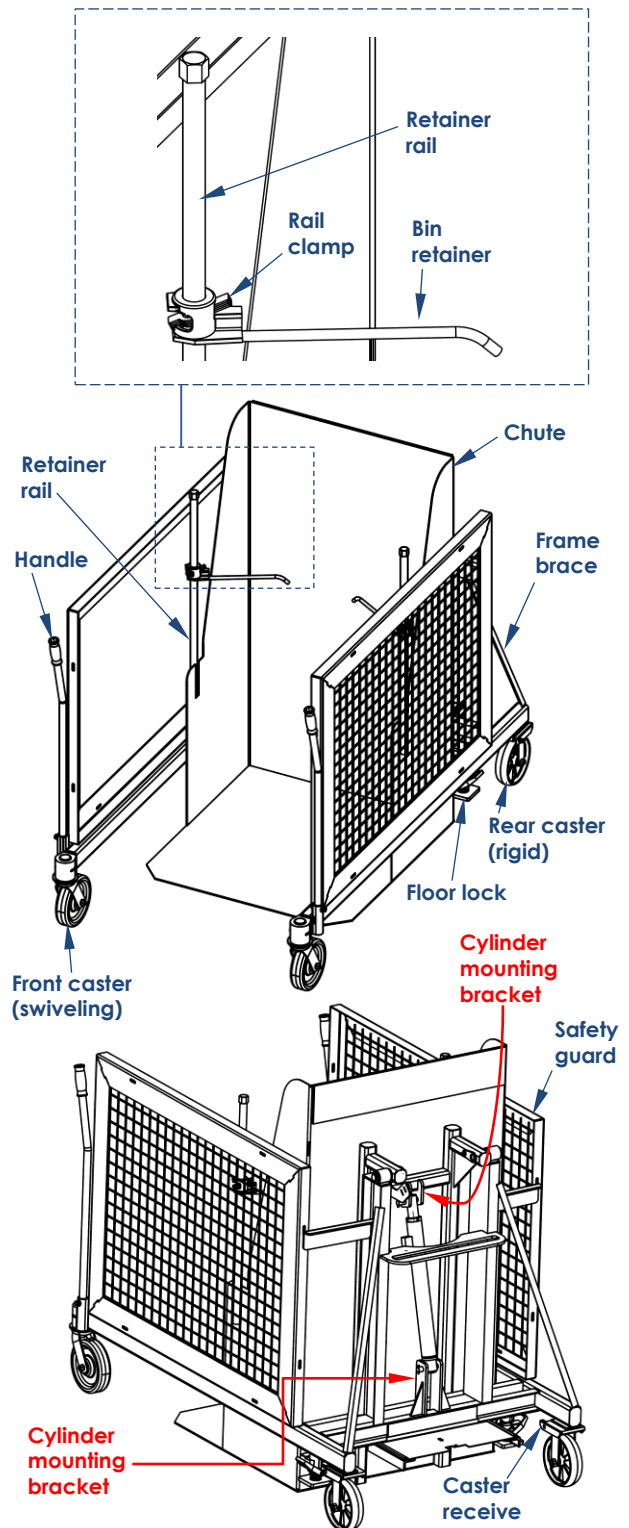

**Shown without MPU for clarity

Troubleshooting

⚠ WARNING

DO NOT attempt to resolve any issue discussed below UNTIL the chute is fully lowered and the power supply is disconnected.

Contact [TECHNICAL SERVICE](#) to discuss any issue that is not addressed in this guide or if you need assistance implementing a solution described in this guide.

<u>Issue</u>	<u>Possible cause(s)</u>	<u>Solution</u>
1. Power unit doesn't run when UP button is pressed.	1a. Transformer fuse is blown. b. No/low supply voltage. c. Upper-travel limit switch is engaged or bad. d. Faulty connection in control circuit. e. Bad control transformer. f. Open motor relay coil. g. (DC units) Low battery voltage.	1a. Test with meter; replace if bad. b. Test with meter. Check fuses, breakers, and overloads to determine the cause. c. Inspect and test switch. Replace if bad. d. Test all parts of circuit with meter. e. Check for 24 VAC; replace if bad. f. Test with meter; replace if bad. g. Test with meter. Charge battery if low.
2. Motor runs properly, but chute doesn't move. Motor and pump are quiet.	2a. Incorrect motor rotation. b. Pump failure. c. Low hydraulic fluid level.	2a. Verify motor shaft rotates counterclockwise. b. Consult factory for replacement. c. Ensure reservoir is filled.
3. Motor hums, chatters, or buzzes, or some type of squeal can be heard, but the chute either does not move or only moves very slowly.	3a. See 2b above. b. Excess voltage drop to motor due to power wire size too small, wire run too long, or incoming voltage too low. c. (3-phase motors) Motor is "single-phasing". d. Pressure relief opening at full pressure. e. Contamination holding open the lowering valve or the check valve.	3a. Same as 2b. b. Check power installation for adequacy. Check incoming voltage <i>while motor is running</i> . Correct problem(s). c. Determine cause of loss of voltage on one phase; correct. d. Check for structural damage or binding of the rollers, etc. Check for chute overload condition. e. Remove and inspect. Clean the valve with mineral spirits.
4. Chute elevates, then drifts down.	4. See 3e above.	4. Same as 3e.
5. Chute lowers too slowly.	5a. Flow control spool is stuck. b. Pinched hose. c. Velocity fuse locking (chute only slowly creeps down).	5a. Remove plug from FC port; push down on the center of the flow spool to ensure it moves freely. b. Check pressure, supply, and return hoses for kinks. c. Same as 7 (below).
6. Chute lowers too quickly.	6a. See 3e. b. Flow control spool is stuck.	6a. Same as 3e. b. Same as 5a.
7. Spongy or jerky chute motion.	7. Air in the hydraulic cylinders.	7. Bleed air per procedure described on p. 10 of this manual.

Labeling diagrams

The unit should be labeled as shown in the diagram. However, label content and location are subject to change so your product might not be labeled exactly as shown. Replace all labels that are damaged, missing, or not easily readable (e.g. faded). Order replacement labels by contacting the [Parts Department](#) online at <https://www.vestil.com/page-parts-request.php>. Alternatively, you may request replacement parts and/or service by calling (260) 665-7586 and asking the operator to connect you to the Parts Department.

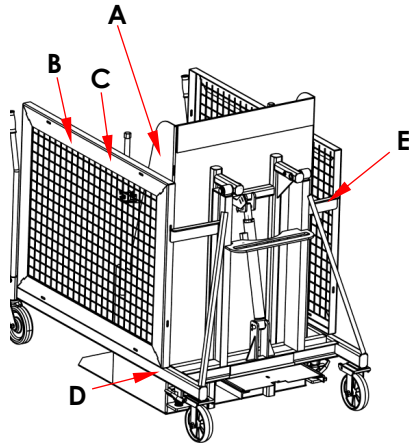

A: Label 725 (applied to both sides of chute)

▲WARNING	
This machine has a drum chute that elevates and pivots. The operator and/or bystanders might sustain serious personal injuries if the drum dumper is improperly used. Reduce the likelihood of injury by conforming use to the following recommendations:	
<ul style="list-style-type: none"> • DO NOT exceed maximum rated load. • DO NOT operate dumper unless BOTH rim clamps securely engage drum. • DO NOT lift people with chute or allow people to ride on chute. DO NOT pass beneath or stand under chute when raised or tilted or allow others to do so. • DO NOT leave elevated or tilted drum unattended. Immediately after dumping drum, return chute to vertical position, fully lower it, and remove dumped drum. • DO NOT modify machine in any way. Modifications may cause malfunctions and might make dumper unsafe to use. • Instruct all people to clear area BEFORE operating dumper. • DO NOT load or operate dumper UNLESS securely attached to floor. 	
<small>725</small>	

B: Label 208 (side guard, both sides)

▲WARNING	▲ADVERTENCIA	▲AVERTISSEMENT
KEEP CLEAR OF PINCH POINT	MANTENGASE ALEJADO DEL PUNTO DE CORTE	SE TENIR À DISTANCE DU POINT DE PINCEMENT
<small>208A</small>		

C: Label 220 (side guard, both sides)

▲WARNING	▲ADVERTENCIA	▲AVERTISSEMENT
KEEP CLEAR WHEN IN USE	MANTENGASE ALEJADO CUANDO SE ESTA OPERANDO	SE TENIR À DISTANCE LORS DU FONCTIONNEMENT
<small>220 Rev. 0311</small>		

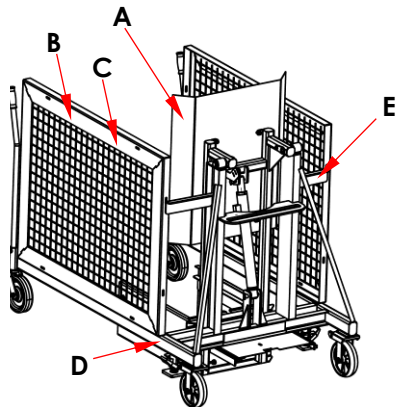

D: Label 212 (both sides)

▲WARNING	▲ADVERTENCIA	▲AVERTISSEMENT
Immobilize by applying all caster brakes and/or floor locks when in use, loading, and unloading.	Inmovilice aplicando todos los frenos de las ruedas y / o bloqueos del piso cuando esté en uso, cargando y descargando.	Immobiliser en appliquant tous les freins des roulettes et / ou les verrous de plancher lors de l'utilisation, du chargement et du déchargement.
<small>212 Rev. 0920</small>		

E: Label 1153 (on nosing of a step)

MODEL / MODELO / MODÈLE	_____
WEIGHT / PESO / MASS	_____
CAPACITY / CAPACIDAD / CAPACITÉ	_____
SERIAL / SERIE / SÉRIE	_____
<small>UNITS: 2.2 lb. = 1kg 1" (or 1in.) = 2.54cm</small>	
1153	

Modular Power Unit (MPU)

The labels shown below are applied to original/first generation power units. Trash dumpers built after 12/01/19 receive 2nd generation modular power units (MPU-GEN2). There are separate manuals for MPU-GEN2 power units. These manuals include labeling diagrams. If you purchased a trash dumper on or after 12/01/18, then you should receive an MPU-GEN2 instruction manual. Refer to the *Labeling Diagram* in that manual.

Label 206 (close to or on oil reservoir)

ISO 32 / 150 SUS	
HYDRAULIC OIL OR NON-SYNTHETIC TRANSMISSION FLUID	
ACEITE HIDRAULICO O LIQUIDOS DE TRANSMISION NO SINTETICOS	
HUILE OU LIQUIDE HYDRAULIQUE NON-SYNTHEIQUE	
<small>206 Rev. 1003</small>	
<small>VESTIL MANUFACTURING CORPORATION • Phone (260) 665-7586 • www.vestil.com</small>	

Label 295 (front and back of MPU)

▲WARNING	
Enclosed battery contains hazardous chemicals.	
DO NOT handle enclosed battery UNLESS wearing eye protection and other appropriate personal protective equipment.	
DO NOT directly contact skin with battery.	
DO NOT expose to sparks or extreme heat; battery contains explosive gases.	
▲ADVERTENCIA	
La batería incluida contiene materiales peligrosos.	
NO use la batería incluida A NO SER que lleve protección de ojos y otros equipos de protección apropiados para el personal.	
NO tenga contacto directo en la piel con la batería.	
NO exponga a destellos o a calor excesivo, la batería contiene gases explosivos.	
	
<small>295 Rev. 0111</small>	

[AC Units only] **Label 248 , 249 , 250 , or 251** (electrical system specifications)

NOTICE	NOTA	AVIS
POWER SUPPLY: _____ V/ Phase/ HZ		
CONTROL VOLTAGE: _____ V AC		
CORRIENTE: _____ V/ Fase/ HZ		
VOLTAJE DE CONTROL: _____ V CA		
ALIMENTATION ÉLECTRIQUE: _____ V/ Monophase/ HZ		
VOLTAGE DE CONTRÔLE: _____ V AC		

- 248** = 115VAC, 1-phase
- 249** = 208-230VAC, 3-phase
- 250** = 460VAC, 3-phase
- 251** = 208-230VAC, 1-phase

LIMITED WARRANTY

Vestil Manufacturing Company ("Vestil") warrants this product to be free of defects in material and workmanship during the warranty period. Our warranty obligation is to provide a replacement for a defective, original part covered by the warranty after we receive a proper request from the Warrantee (you) for warranty service.

Who may request service?

Only a warrantee may request service. You are a warrantee if you purchased the product from Vestil or from an authorized distributor AND Vestil has been fully paid.

Definition of "original part"?

An original part is a part used to make the product as shipped to the Warrantee.

What is a "proper request"?

A request for warranty service is proper if Vestil receives: 1) a photocopy of the Customer Invoice that displays the shipping date; AND 2) a written request for warranty service including your name and phone number. Send requests by one of the following methods:

<u>US Mail</u>	<u>Fax</u>	<u>Email</u>
Vestil Manufacturing Company 2999 North Wayne Street, PO Box 507 Angola, IN 46703	(260) 665-1339 <u>Phone</u> (260) 665-7586	info@vestil.com Enter "Warranty service request" in the subject field.

In the written request, list the parts believed to be defective and include the address where replacements should be delivered. After Vestil receives your request for warranty service, an authorized representative will contact you to determine whether your claim is covered by the warranty. Before providing warranty service, Vestil will require you to send the entire product, or just the defective part (or parts), to its facility in Angola, IN.

What is covered under the warranty?

The warranty covers defects in the following original, dynamic parts: motors, hydraulic pumps, motor controllers, and cylinders. It also covers defects in original parts that wear under normal usage conditions ("wearing parts"), such as bearings, hoses, wheels, seals, brushes, and batteries.

How long is the warranty period?

The warranty period for original dynamic components is 1 year. For wearing parts, the warranty period is 90 days. Both warranty periods begin on the date Vestil ships the product to the Warrantee. If the product was purchased from an authorized distributor, the periods begin when the distributor ships the product. Vestil may, at its sole discretion, extend a warranty period for products shipped from authorized distributors by up to 30 days to account for shipping time.

If a defective part is covered by the warranty, what will Vestil do to correct the problem?

Vestil will provide an appropriate replacement for any covered part. An authorized representative of Vestil will contact you to discuss your claim.

What is not covered by the warranty?

The Warrantee (you) is responsible for paying labor costs and freight costs to return the product to Vestil for warranty service.

Events that automatically void this Limited Warranty.

- Misuse;
- Negligent assembly, installation, operation or repair;
- Installation/use in corrosive environments;
- Inadequate or improper maintenance;
- Damage sustained during shipping;
- Collisions or other accidents that damage the product;
- Unauthorized modifications: Do not modify the product IN ANY WAY without first receiving written authorization from Vestil.

Do any other warranties apply to the product?

Vestil Manufacturing Co. makes no other express warranties. All implied warranties are disclaimed to the extent allowed by law. Any implied warranty not disclaimed is limited in scope to the terms of this Limited Warranty. Vestil makes no warranty or representation that this product complies with any state or local design, performance, or safety code or standard. Noncompliance with any such code or standard is not a defect in material or workmanship.

