

TOOLS REQUIRED



Allen Wrench

(Included)



Phillips
Screwdriver

(Not Included)



2 - People
Recommended

ASSEMBLY RATING



EASY —————> DIFFICULT

The Assembly Rating is a 5-point system showing the level of effort needed to assemble a specific product.

BED



- Please keep instructions for future reference.
- Check the quantity and irregularity of parts and hardware before you start.

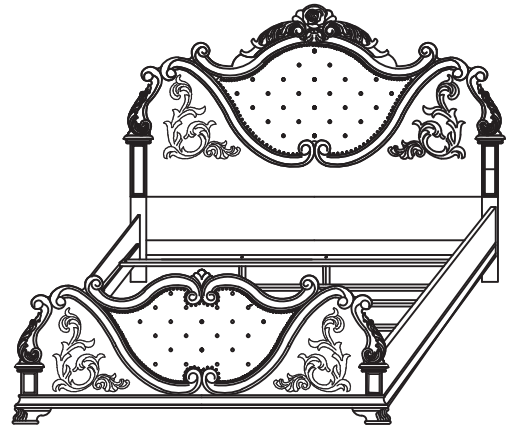

PARTS

#1 1pc



Headboard

#2 2pcs



Headboard leg(L&R)

#3 1pc

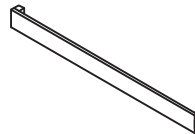

HB Cross bar

#4 1pc



Footboard

#5 2pcs

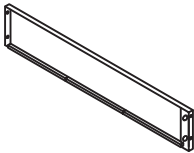

Siderail

#6 4 pcs



Slat

#7 4pcs

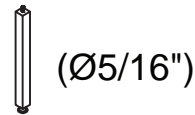

Slat support leg
250x30x30mm

HARDWARE

#A 8pcs



Bolt Ø5/16" x 2"

#B 12pcs



Lock Washer Ø5/16"

#C 12pcs



Flat Washer Ø5/16"

#D 1pc

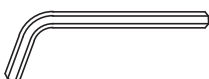

Allen key M4

#E 8pcs



Screw #4 x 32mm

#F 8pcs



Ø5/16" * 3-1/4"

HARDWARE

#G 8pcs



Half Moon Washer
(Ø5/16")

#H 8pcs



Hex Nut (Ø5/16")

#I 1pc



Wrench 14mm







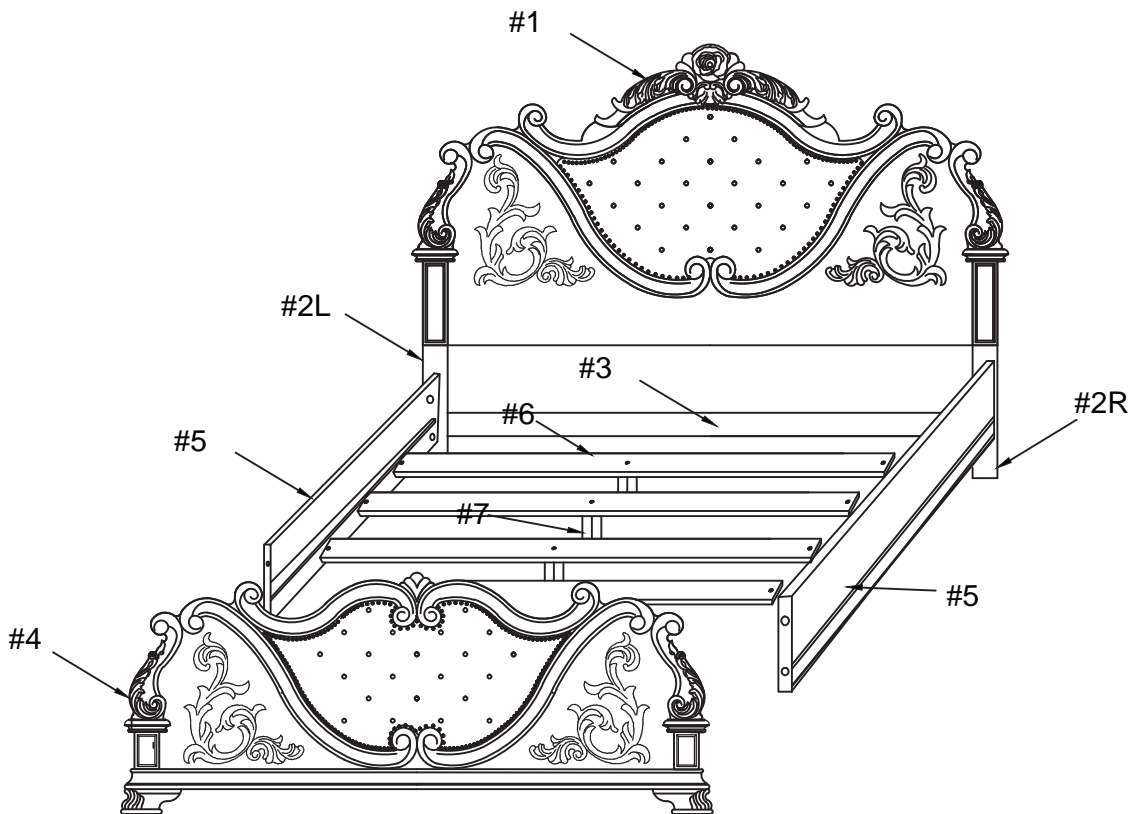









#J 4pcs



Bolt Ø5/16" x 1-1/2"



QUEEN is packed in 3 cases

Carton	Disignation	Part		Hardware
HEADBOARD	Headboard	#1		
	Headboard leg(L&R) x 2pcs	#2		
	HB Cross bar	#3		
FOOTBOARD	Footboard	#4		 #A x8pcs  #B x12pcs  #C x12pcs  #D x1pc  #E x8pcs  #F x8pcs  #G x8pcs  #H x8pcs  #I x1pc  #J x4pcs
	Slat x 4pcs	#6		
	Slat support leg 250x30x30mm x4pcs	#7		
RAILS	Siderail x2pcs	#5		

ASSEMBLY INSTRUCTIONS

Align the Headboard leg L&R (#2) to the back of Headboard (#1) and secure by using Bolt (#A) with Lock washer (#B) and Flat washer (#C).

1

Part #1 x1pc

Part #2 x2pcs

Hardware #A x8 pcs

Hardware #B x8 pcs

Hardware #C x8 pcs

Hardware #D x1 pc

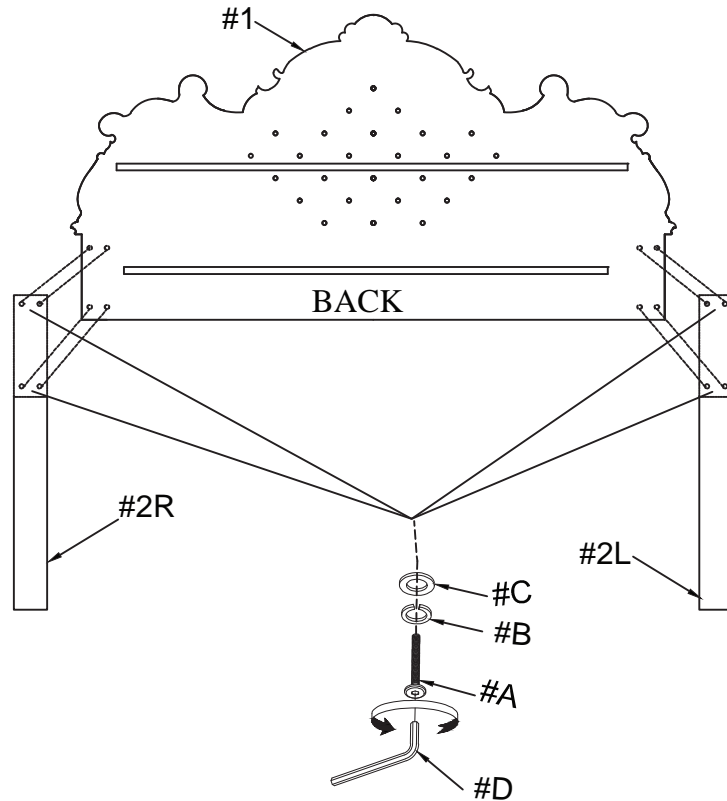

2

Part #3 x1pc

Hardware #J x4 pcs

Hardware #B x4 pcs

Hardware #C x4 pcs

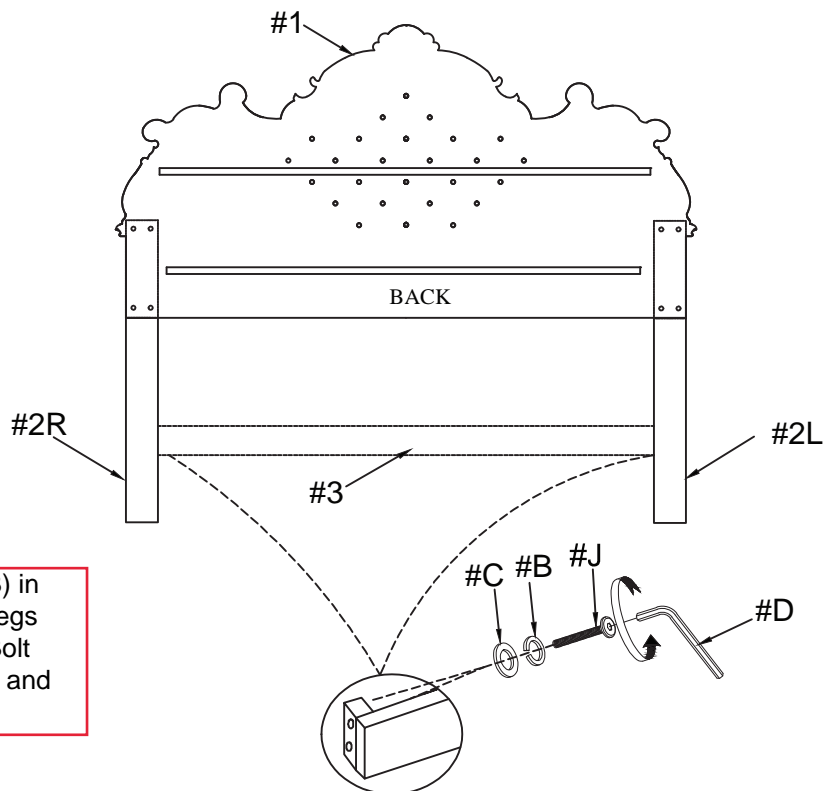

Insert the HB cross bar (#3) in between the Headboards legs (#2) and secure by using Bolt (#J) with Lock washer (#B) and Flat washer (#C).

ASSEMBLY INSTRUCTIONS

3

Part #1 x1pc

Part #4 x1pcs

Part #5 x2pcs

Hardware #H x8 pcs

Hardware #G x8pcs

Hardware #F x8pcs

Attach Part # F to the Headboard legs (#2) and the Footboard (#4). Align the Side rails (#5) and secure with Half moon washer (#G) and Hex nut (#H).

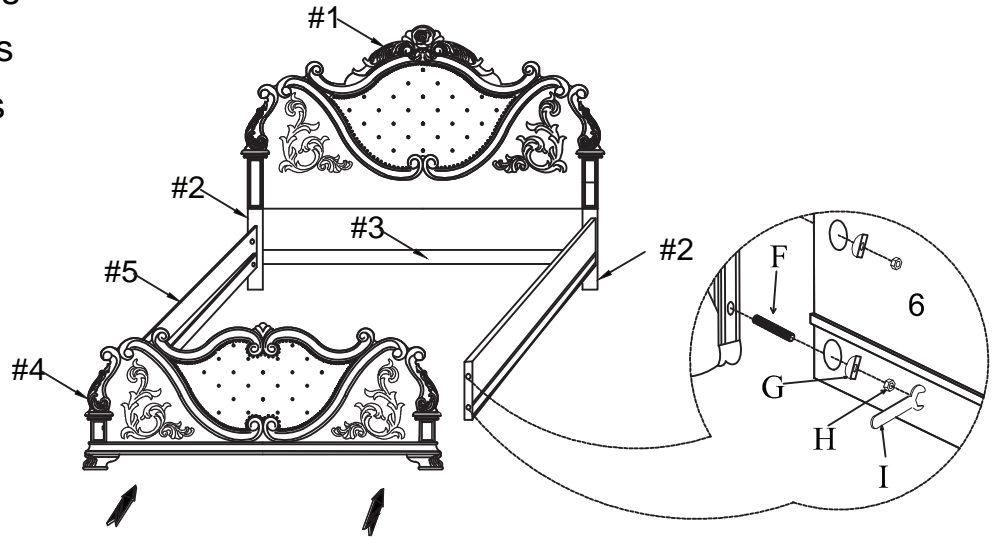

4

Part #6 x1pc

Part #7 x1pc

Twist the Slat support leg(#7) onto the Slat (#6). Use levelers to adjust the height of the support leg.

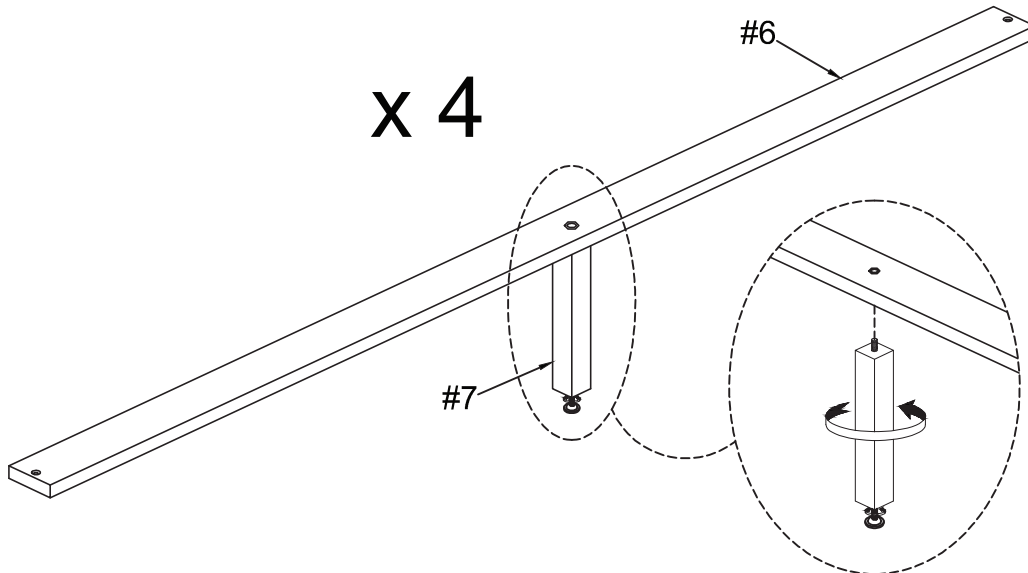

ASSEMBLY INSTRUCTIONS

5

Hardware **#E** x8 pcs

Align Slats (#6) with evenly within the frame and secure by using Screw (#E).

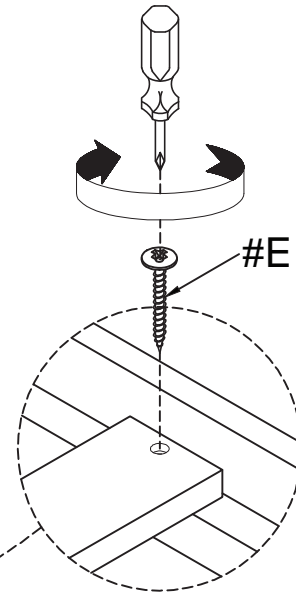
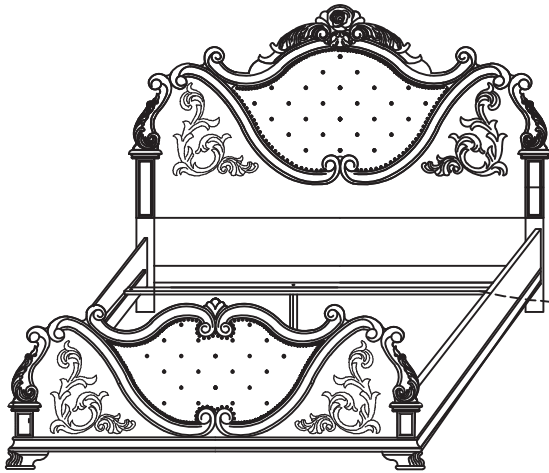

#5

6

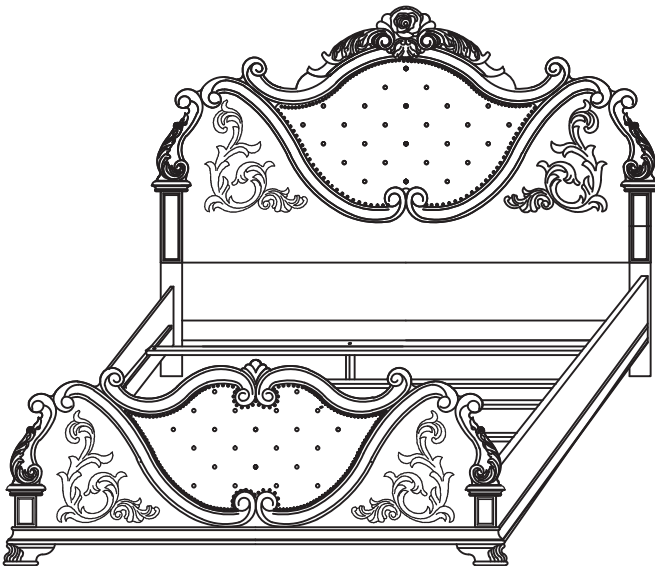

ASSEMBLY COMPLETED



Please ensure the furniture rests on an even and flat surface. If the product wobbles or feels loose, double-check all bolts and/or screws are properly tightened and secured.

✓ Keep this handy!

Please retain this instruction manual and any order-related information for future reference.

✓ Lift, don't drag!

To avoid damage to product please always LIFT the product when transporting or adjusting the placement.