

ASSEMBLY INSTRUCTION | Montageanweisung | Instructions de montage
Istruzioni per l'assemblaggio | 組み立て指示 (くみ立てしゅうじ) | Instrucciones de montaje

1. Please read the assembly instructions carefully before assembling and check all the parts.
2. DO not touch the cut surface of tube
3. Please ensure that you assemble the parts according to the assembly sequence specified in the instructions.

1. Bitte lesen Sie vor dem Zusammenbau die Montageanleitung genau durch und kontrollieren Sie alle Teile.
2. Berühren Sie die geschnittene Oberfläche des Rohres nicht.
3. Stellen Sie sicher, dass Sie die Teile nach der vorgegebenen Montagefolge zusammenbauen.

1. Veuillez lire attentivement les instructions d'assemblage avant de procéder à l'assemblage et de vérifier toutes les pièces.
2. Ne touchez pas la surface coupée du tube.
3. Assurez-vous de monter les pièces selon la séquence d'assemblage précisée.

1. Leggere attentamente le istruzioni di montaggio prima di assemblare e verificare tutti i componenti.
2. Non toccare la superficie tagliata del tubo.
3. Assicurarsi di assemblare i pezzi seguendo la sequenza di montaggio specificata.

1. 組み立てる前には、組み立て手順を注意深く読み込んで、すべてのパーツを確認してください。
2. タイプの切断面に触らないでください。
3. 指定された組み立て順序に従って、部品を正しく組み立てるようご確認ください。

1. Por favor, lea detenidamente las instrucciones de montaje antes de ensamblar y revise todos los componentes.
2. No toque la superficie cortada del tubo.
3. Asegúrese de montar las piezas siguiendo la secuencia de montaje especificada.

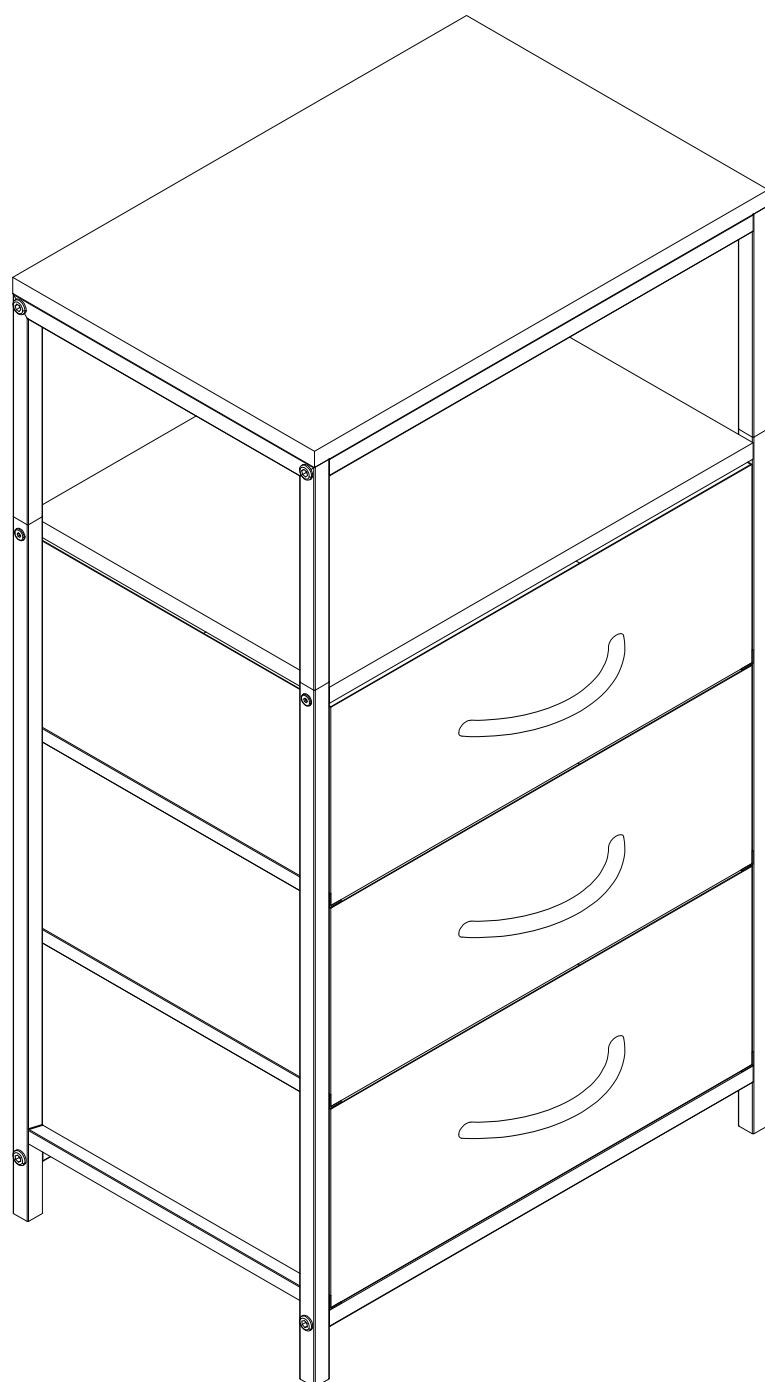

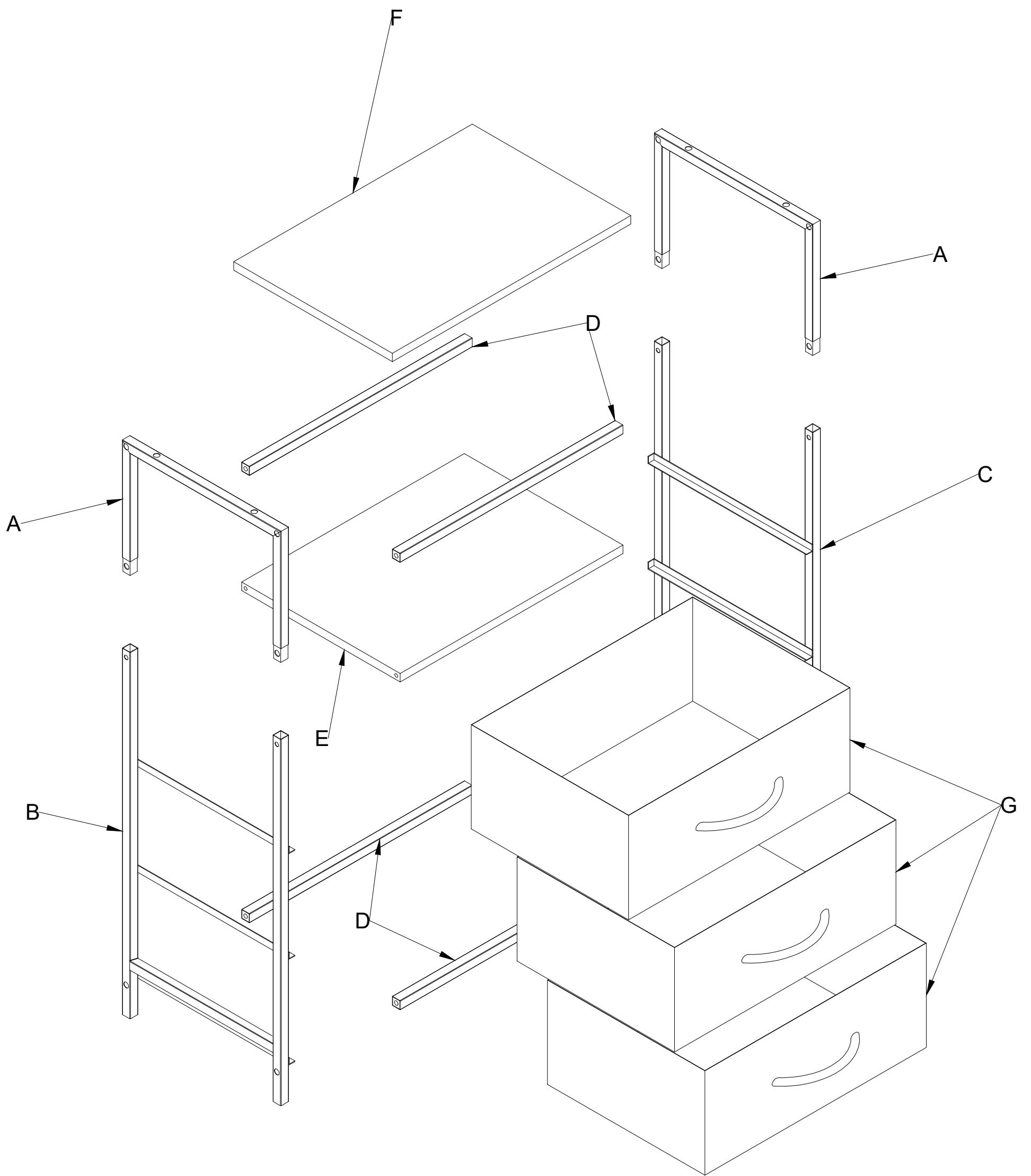

A

x2

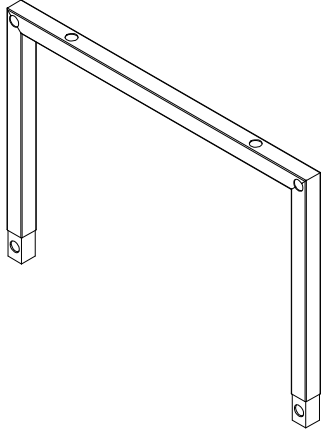

B

x1

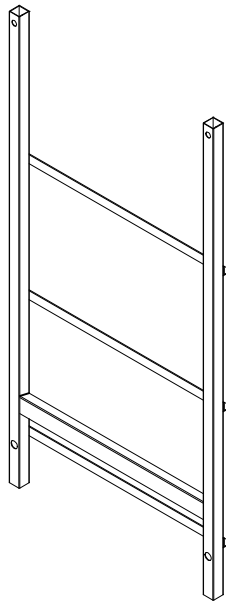

C

x1

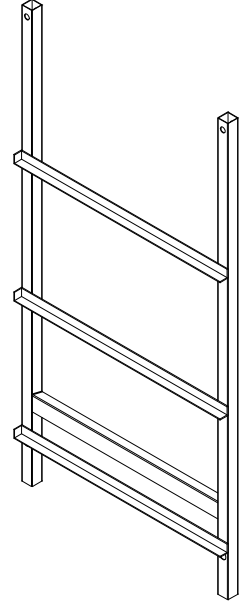

D

x4

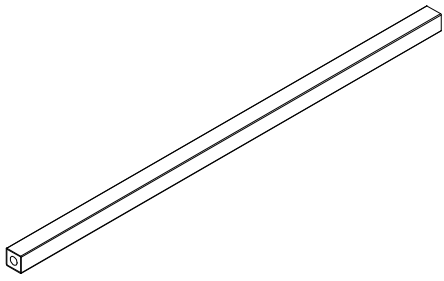

E

x1

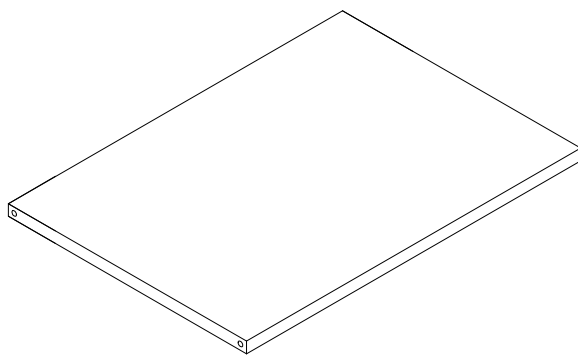

F

x1

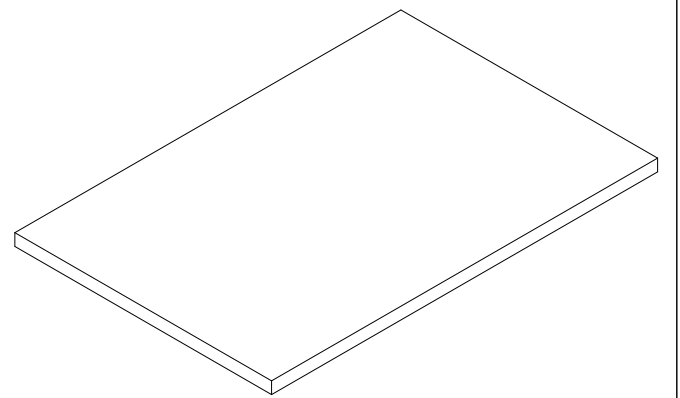

G

x3

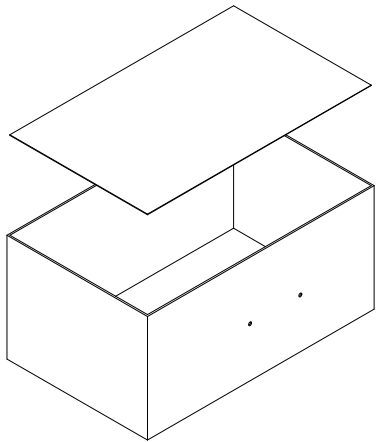

1

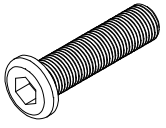

Qty:8

2

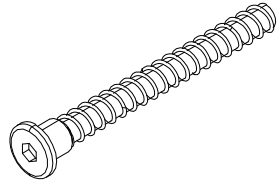

Qty:4

3

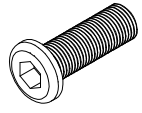

Qty:4

4

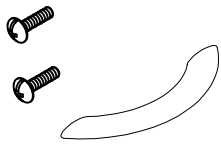

Qty:3

5

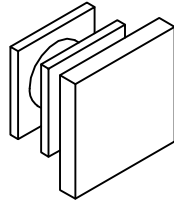

Qty:4

6



7

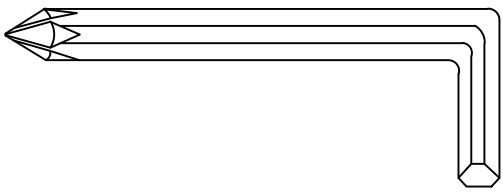

1

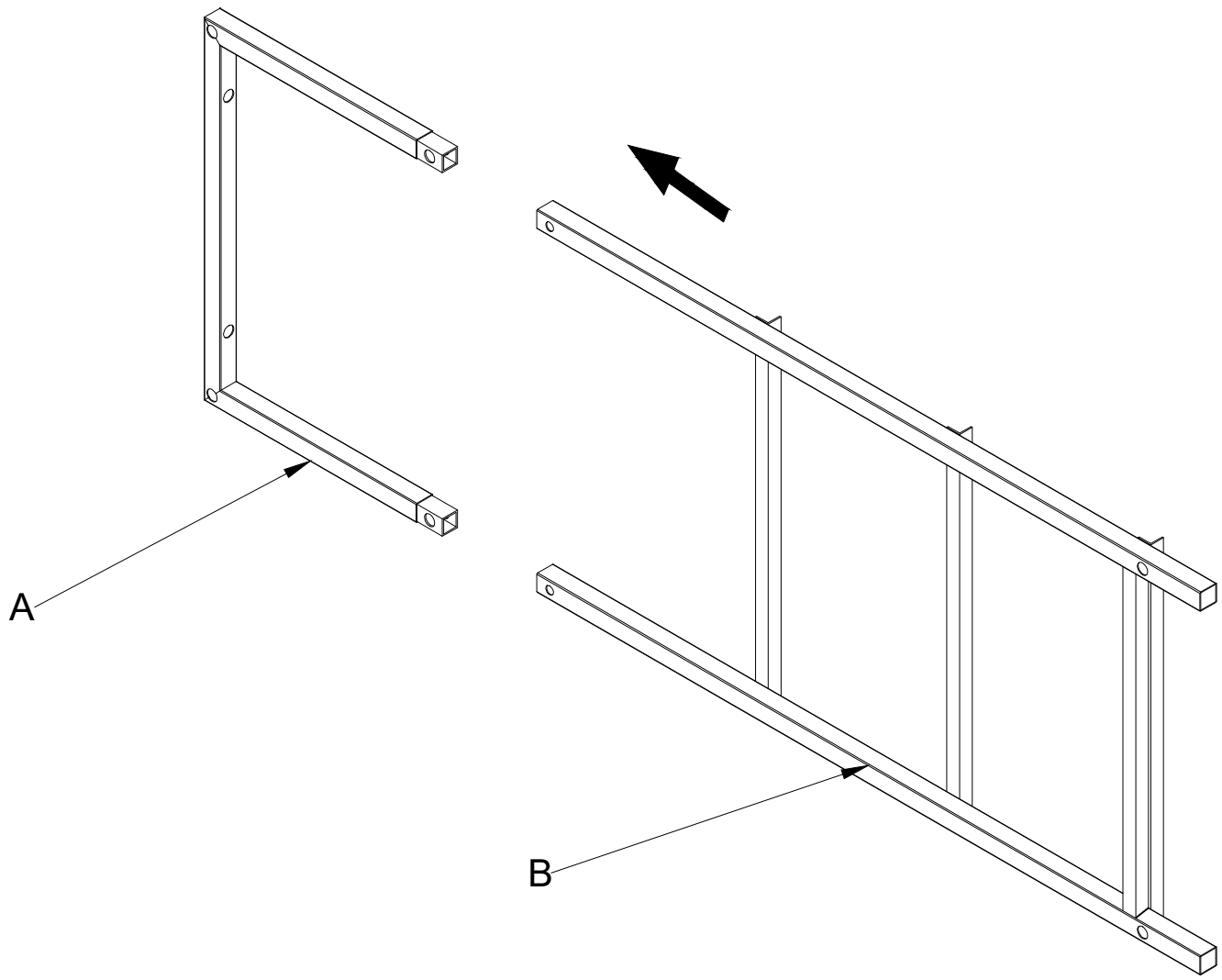

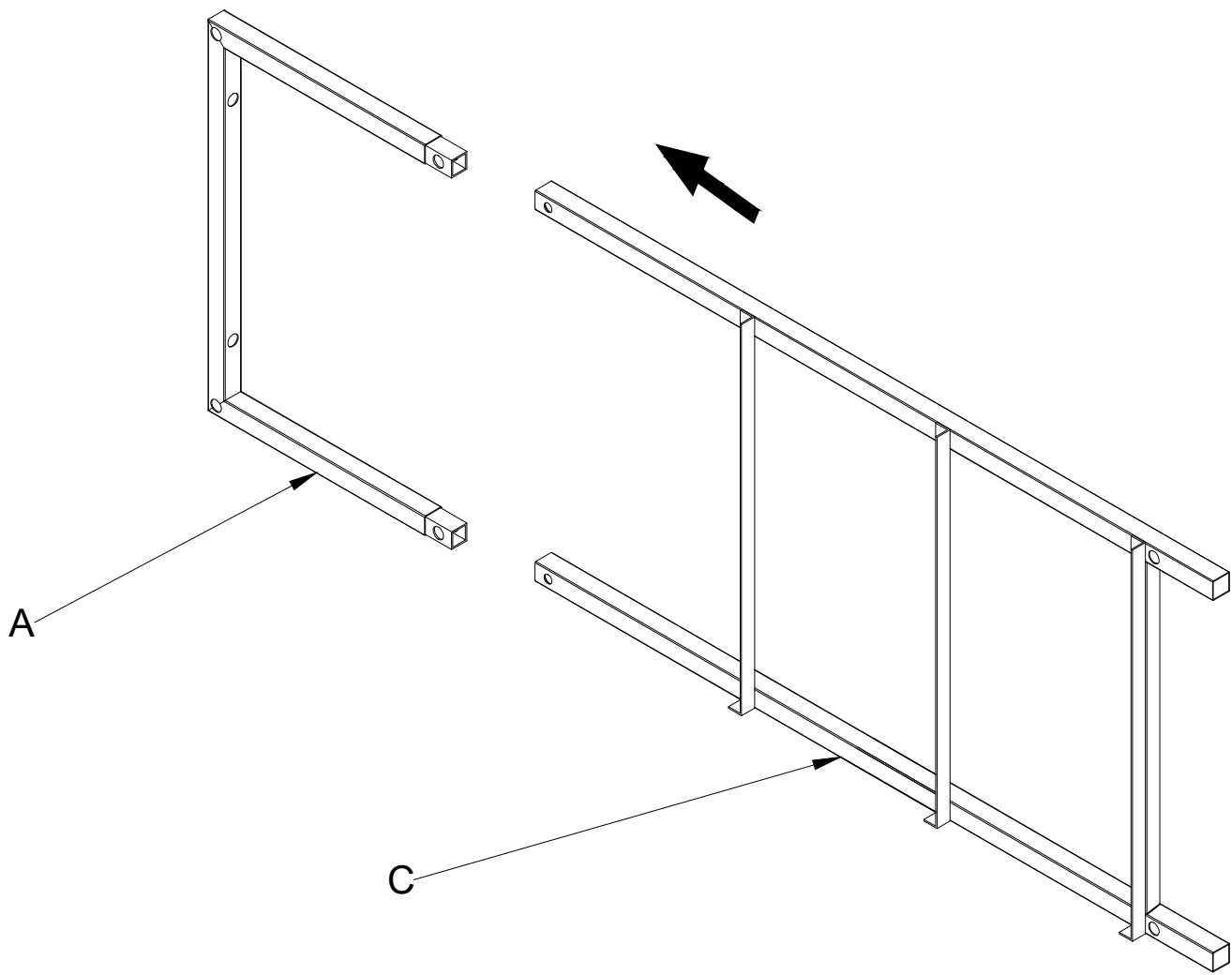

2

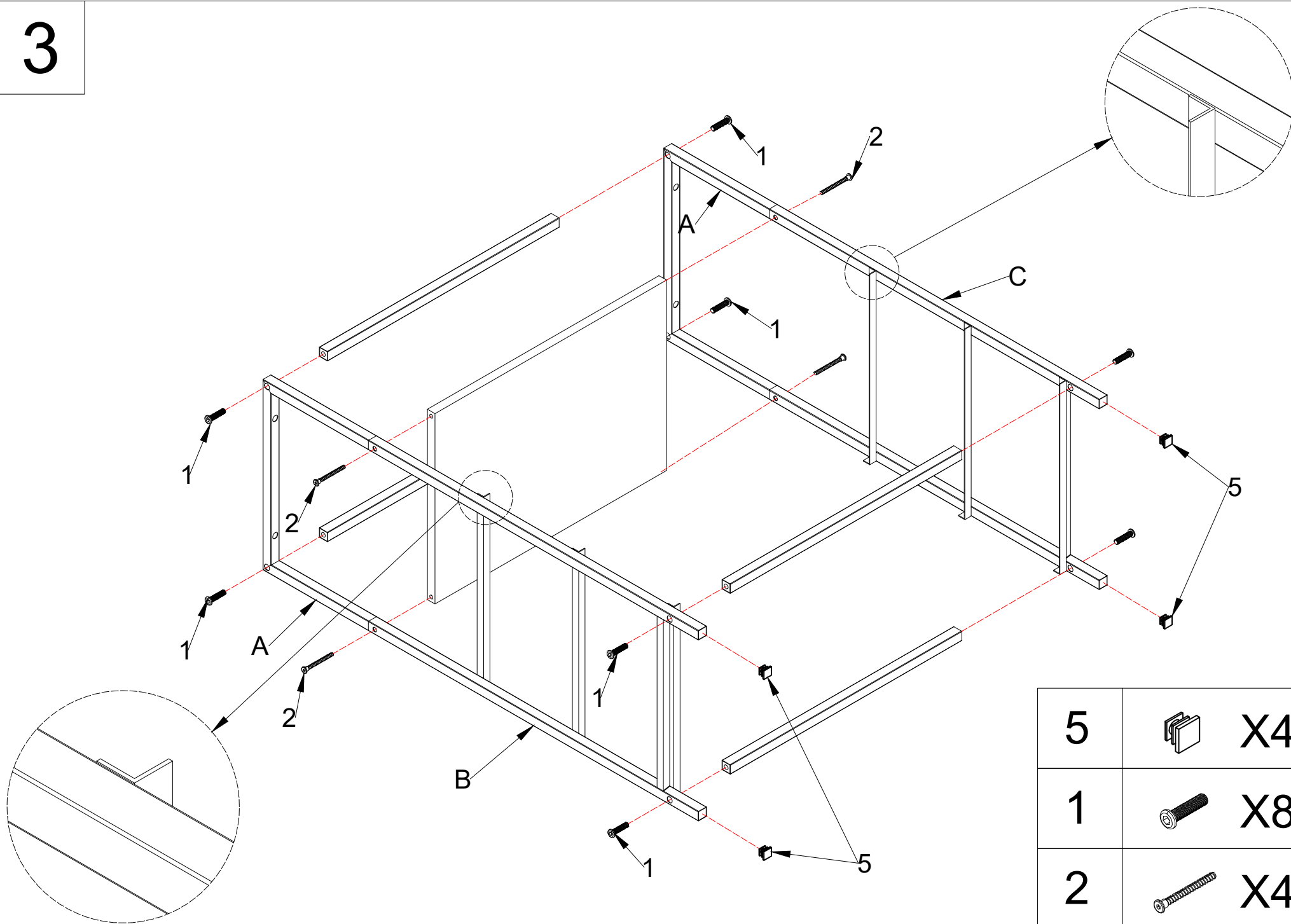

3



5		X4
1		X8
2		X4

4

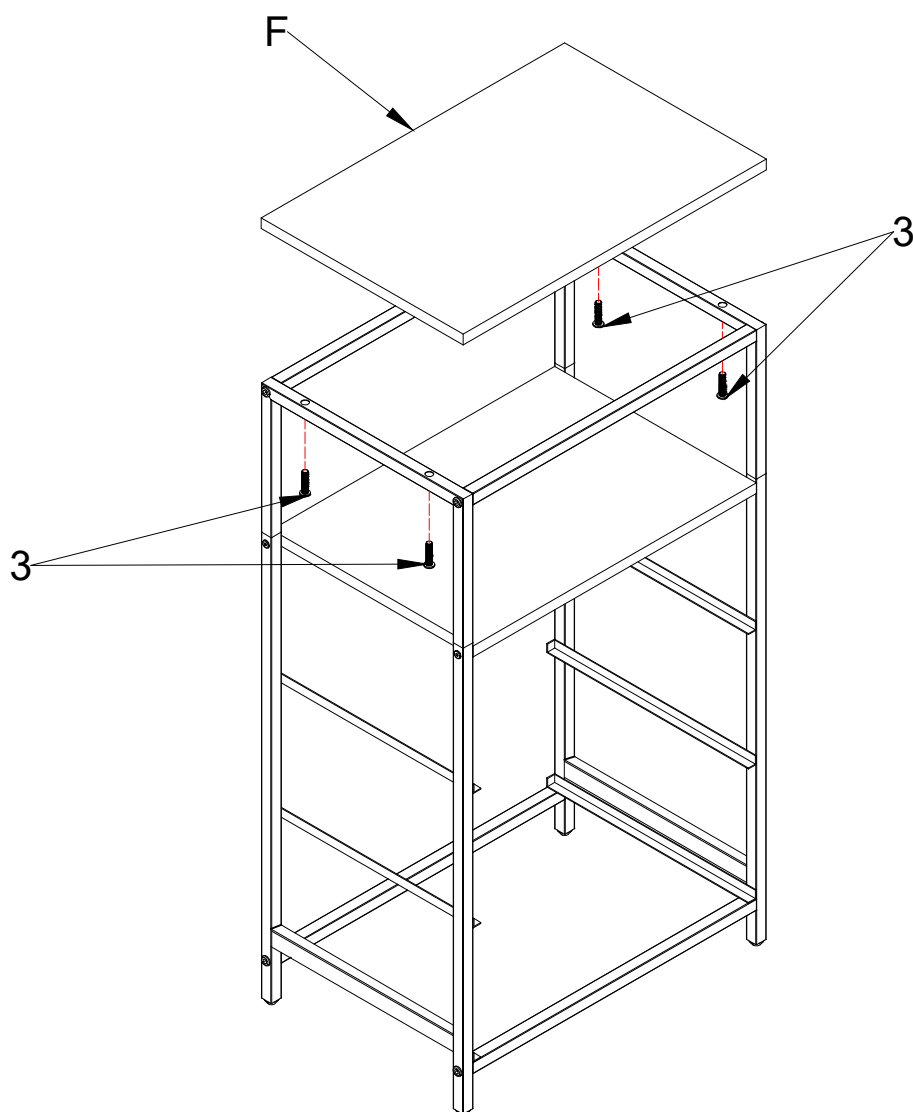

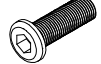
3		X4
---	---	----

5

X3

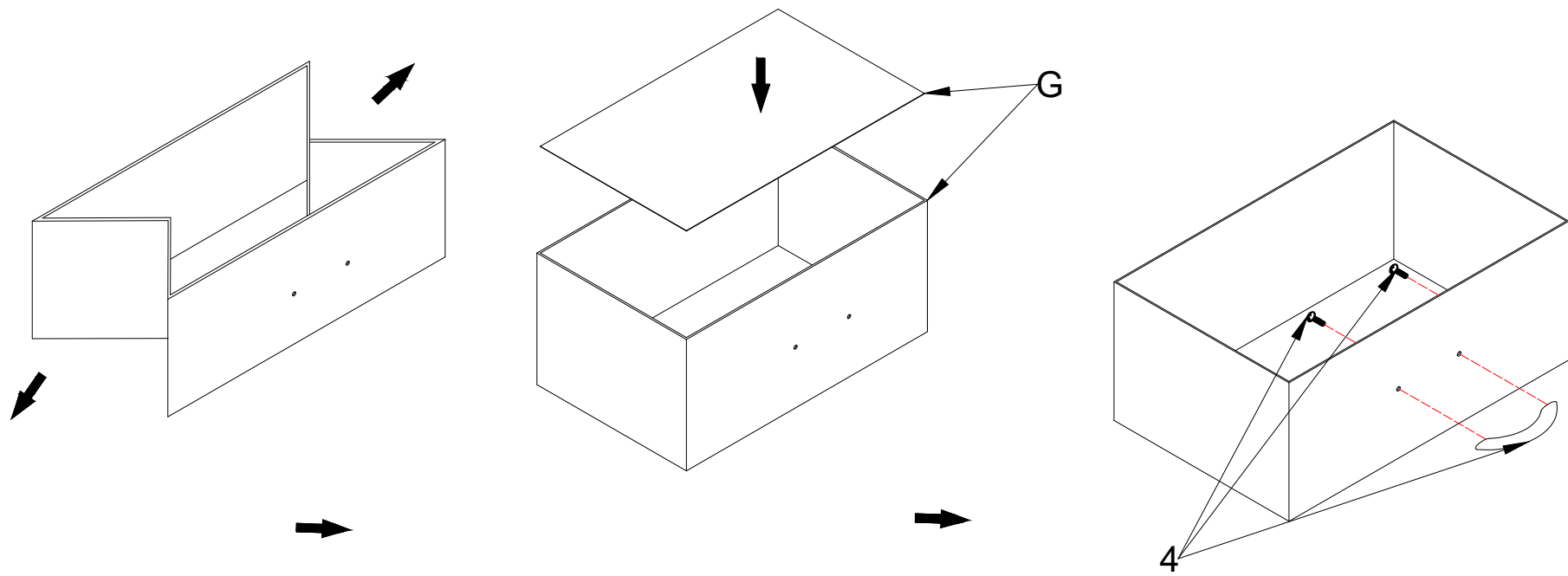

4



X3

6

X3

