

## **“Limited” Warranty**

This warranty is between and the original purchaser and is valid only when accompanied by the original purchaser’s sales receipt showing original date of purchase and location of purchase. Replacements under this warranty revert to the date of original purchase for future warranty. Maintain this warranty document and your sales receipt in a safe place.

or its authorized dealer can accept or reject warranty claims based on its findings. This warranty applies in normal residential use only. Normal residential use only is described as using the product on a level surface with all legs touching the floor with an equal distribution of weight. The product is to be used with standard mattresses only. This warranty is invalid if the product is not used for its intended purpose. We can make substitutions as required of materials, components, and sub-components of comparable value and utility. We reserves the right to refuse service and invalidate the warranty when, upon inspection, the product failure is caused by factors other than defective workmanship or materials.

Manufacturing defects include when the product has become defective where it will not support the mattress properly.

Sales and use taxes, plus shipping and handling charges are the responsibility of the consumer. Consumer is required to deliver damaged product to the authorized dealer.

Certain items are not covered by this warranty. These include, but are not limited to the following:

1. Components subjected to abuse including abuse intended to simulate failure.
2. Damages caused by shipper, dealer, or installation crew such as scratches, dents, fabric tears etc.
3. Any part which merely exhibits normal wear yet functions essentially as new.
4. The disclaims liability for any aspect of installation and any inconvenience caused by a defective part of a component.
5. Tears, punctures, dents, or any damage caused by improper installation.
6. Items sold “as is” and Floor Model Units.
7. The warrants only the products listed at the top of this page. This warranty does not extend to any mattress that may be placed on the listed products.
8. Weight Capacity – King, California King, Queen, Double size – 700 Lbs. Twin size – 400 Lbs.

**Platform Bed**  
**Assembly Instruction**  
Contains One Bed and Hardware

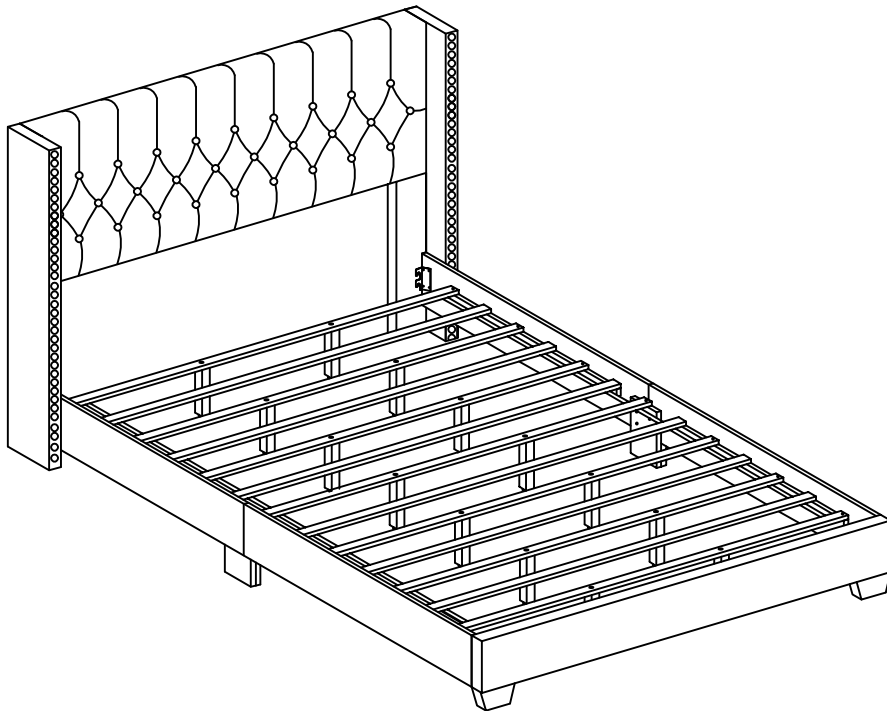

**IMPORTANT NOTE:**

Carefully remove all the parts from the box. Arrange on a flat surface and verify you have all of the following parts and hardware

**TOOLS REQUIRED:**  
Phillips Screwdriver

# PARTS LIST

**A. Headboard (1 pc)**

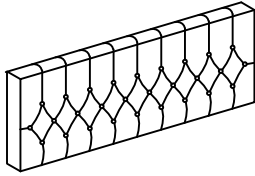

**B. Footboard (1 pc)**



**C. Side Rail (4 pcs)**

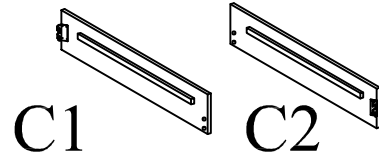

**D. Headboard Legs (2 pcs)**

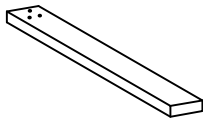

**E. Footboard Legs (2 pcs)**

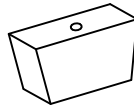

**F. Side Rail Leg (2 pcs)**

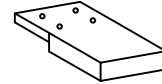

**G. Wood Slat System (1 pc)**

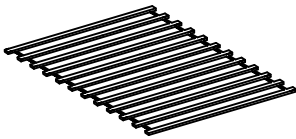

**H. Center Leg (14 pcs)**

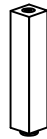

**I. Side Wing (2 pcs)**



# HARDWARE LIST

**J. 20mm Bolt (8 pcs)**

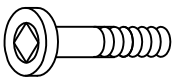

**K. 30mm Bolt (8 pcs)**

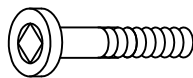

**L. 40mm Bolt (18 pcs)**

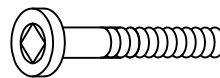

**M. 50mm Bolt (8 pcs)**

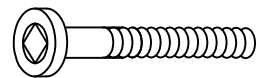

**N. Large Hex Key (1 pc)**



**O. Small Hex Key (1 pc)**

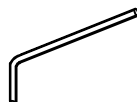

**P. Spring Washer (10 pcs)**



**Q. Flat Washer (12 pcs)**

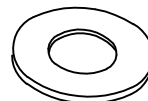

**R. 32mm Screw (14 pcs)**

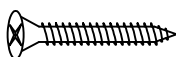

# ASSEMBLY INSTRUCTIONS

## STEP 1

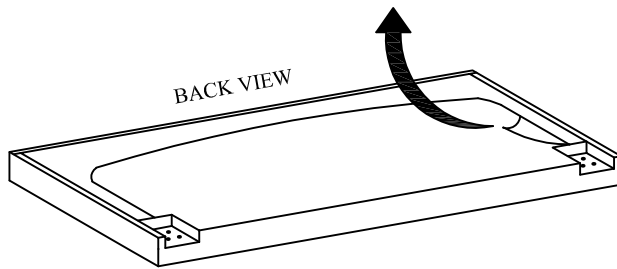

Unzip the black fabric on the back of the headboard and remove the parts. Zip the black fabric closed after parts are removed.

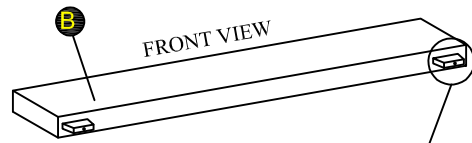

Attach the Footboard Legs (Part E) to the Footboard (Part B) using two 50mm Bolts (Part M) and Large Hex Key (Part N). Secure tightly.

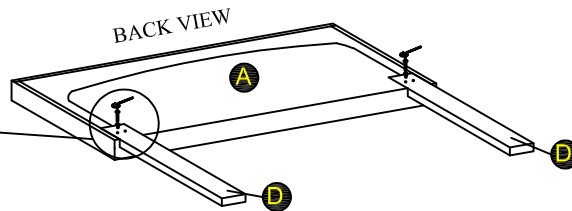
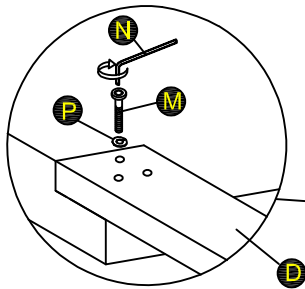
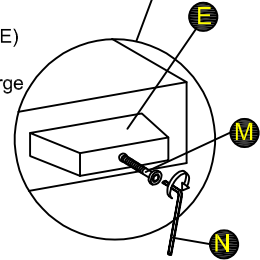

Attach Headboard Legs (Part D) to the Headboard (Part A) using three 50mm Bolts (Part M) and three Spring Washers (Part P) per leg. Secure tightly using Large Hex Key (Part N).

## STEP 2

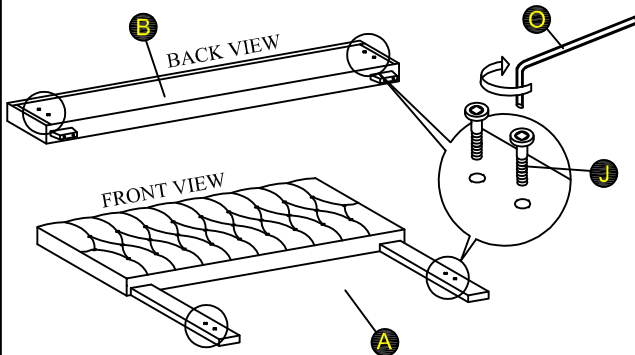

Attach the eight 20mm Bolts (Part J) to the headboard leg and footboard using the Small Hex Key (Part O). Do not tighten.

## STEP 3

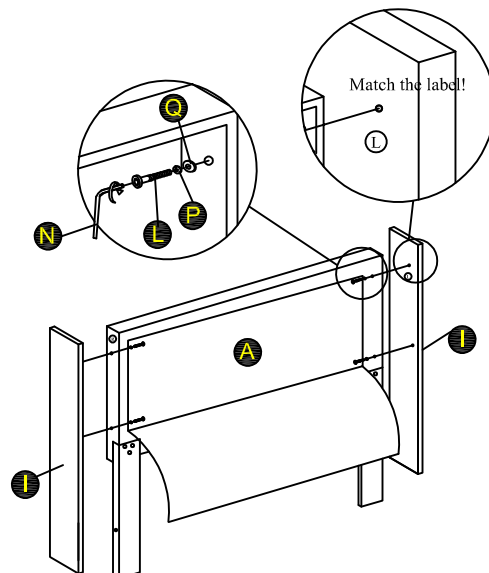

**Attention: Zip the black non-woven fabric after tighten the Screw !!**

Attach the four 40mm Bolts (Part L), four Spring Washer (Part P) and four Flat Washer (Part Q) to the headboard using the Large Hex Key (Part N).

# ASSEMBLY INSTRUCTIONS

## STEP 4

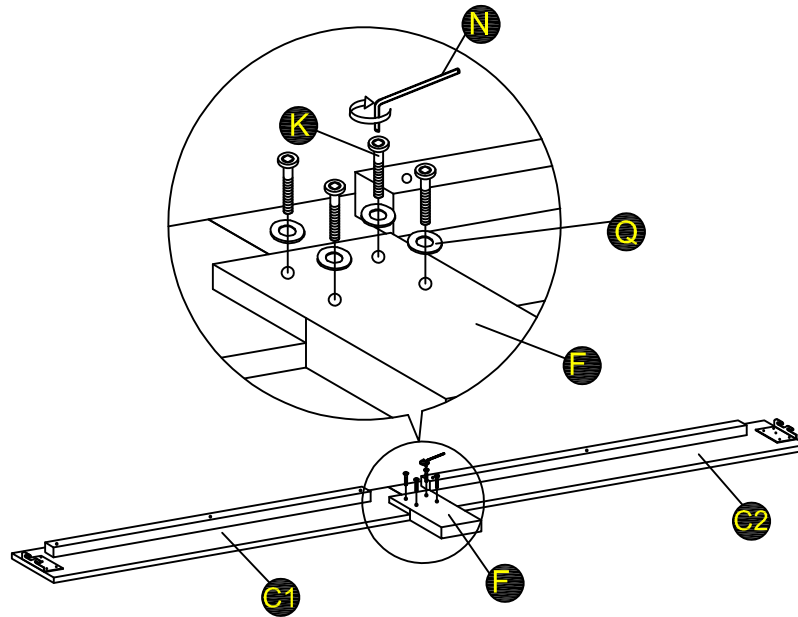

Attach the Side Rails (Parts C1 & C2) to Side Rail Leg (Part F) using four 30mm Bolts (Part K) and four Flat Washers (Part Q). Secure tightly using Large Hex Key (Part N). Repeat this process for the other Side Rail.

## STEP 5

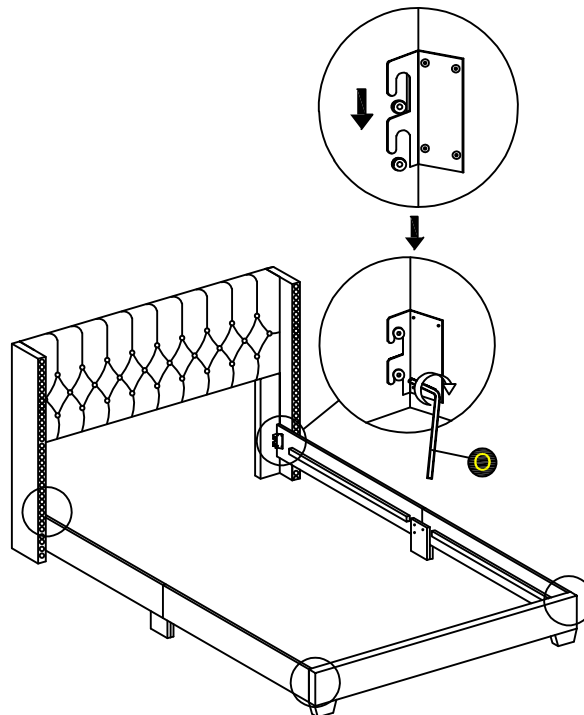

Attach the Side Rails to the Headboard (Part A) and Footboard (Part B) by sliding the side rail brackets onto the bolts on the Headboard Legs (Part D) and Footboard (Part B). Secure tightly using Small Hex Key (Part O).

# ASSEMBLY INSTRUCTIONS

## STEP 6

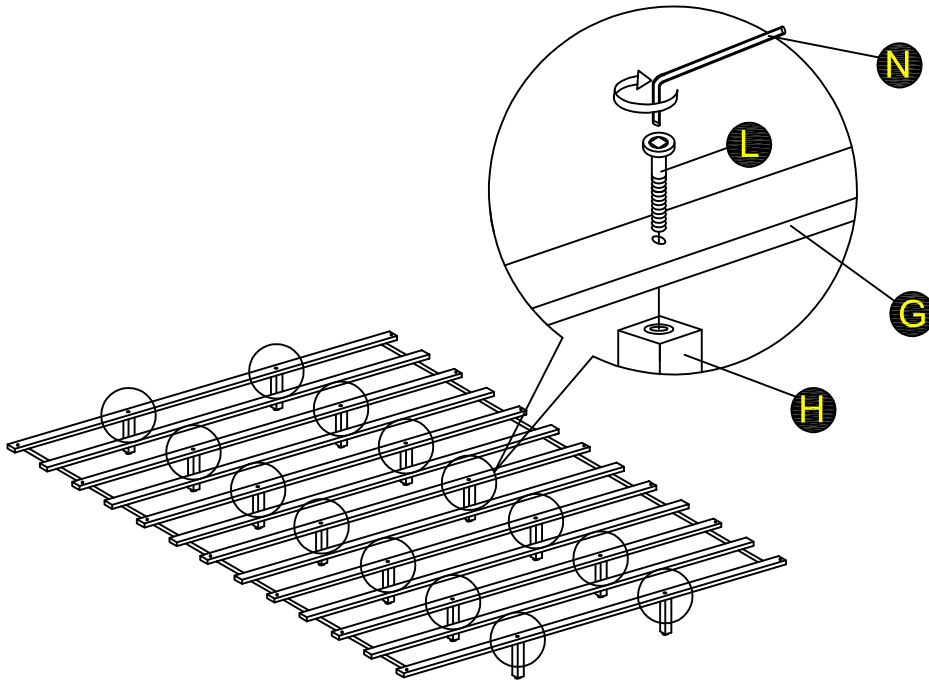

Attach the Center Legs (Part H) to the Wood Slat System (Part G) using 40 mm Bolt (Part L) and Large Hex Key (Part N) to tighten.

## STEP 7

