

DOUBLE DOOR WALL CABINET

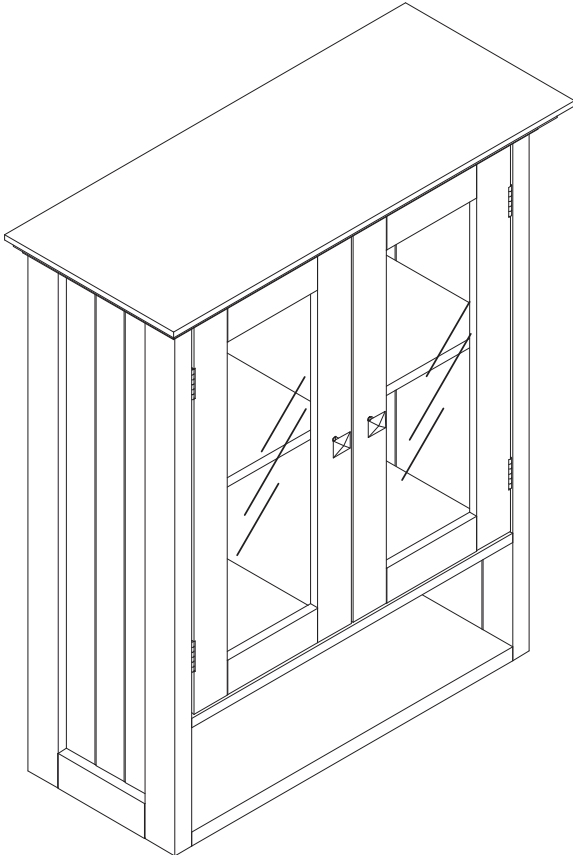



Questions, problems, assembly help, missing parts?

No need to return the product, we will gladly help and ship your replacement parts free of charge
Please call Customer Service

In order to assist you in a timely manner, please have the following information ready:

Model # _____ Part Number or Letter _____

Purchased at _____ Date of Purchase _____

If you wish to return the product, please contact the retailer where the product was purchased.

IMPORTANT : Please read this manual carefully before beginning assembly of this product. Keep this manual for future reference.

SAFETY INFORMATION

Identify all the parts and hardware. Do not discard of the packaging until you have checked that you have all of the parts and hardware required. Hardware package may have spare parts.

WARNING: This item contains small parts which can be swallowed by children and pets. Keep children and pets away during assembly. To avoid danger of suffocation, always keep plastic bags away from children and pets. We recommend that you assemble this unit on a carpeted floor to avoid scratches. If using power tools, set the tool to low torque to avoid damage.

May require 2 people for ease of assembly.

CARE and MAINTENANCE

To clean, use a soft or slightly damp cloth, then wipe with a clean, dry cloth. Dust with soft dry cloth.

Do not use ammonia-based cleaning products, as they will damage the finish.

Do not leave liquids or damp cloths on this furniture.

To avoid dulling of the finish, do not place furniture in direct sunlight.

Please inspect and tighten all screws or bolts on a regular basis to ensure proper performance and safety of your item.

PRE-ASSEMBLY INFORMATION

PARTS DESCRIPTION

A

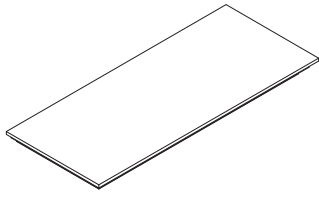

CABINET TOP
QTY 1

B

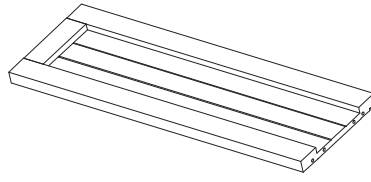

LEFT SIDE PANEL
QTY 1

C

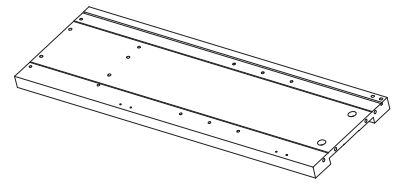

RIGHT SIDE PANEL
QTY 1

D

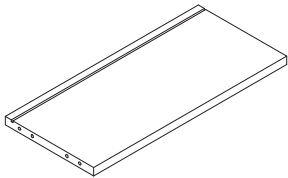

BOTTOM PANEL
QTY 1

E

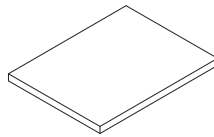

ADJUSTABLE SHELF
QTY 2

F

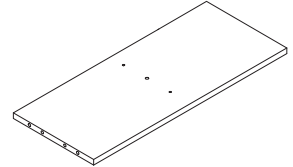

MIDDLE SHELF
QTY 1

G

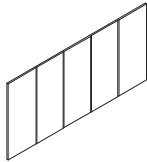

BOTTOM BACK PANEL
QTY 1

H

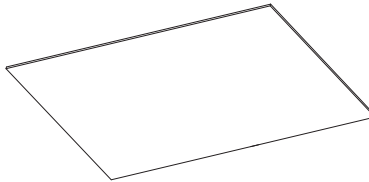

TOP BACK PANEL
QTY 2

I

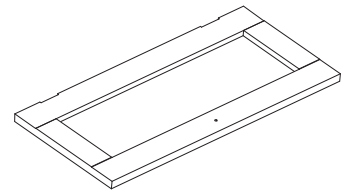

RIGHT SIDE DOOR
QTY 1

J

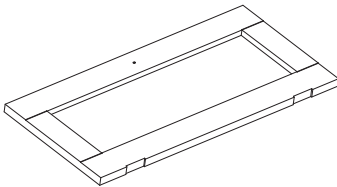

LEFT SIDE DOOR
QTY 1

K

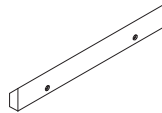

REAR BOTTOM CROSS BAR
QTY 1

L

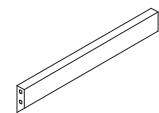

REAR TOP CROSS BAR
QTY 1

M

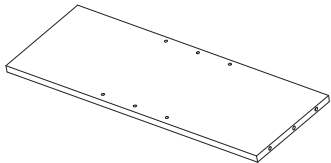

SUPPORT PLATE
QTY 1

N

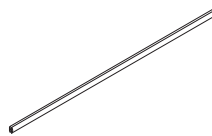









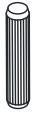





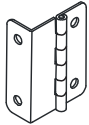
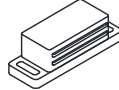

CONNECTOR
QTY 1

NEED HELP? For help with assembly or if you are missing a part,
Please call customer service

PRE-ASSEMBLY INFORMATION

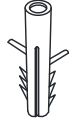
HARDWARE DESCRIPTION

| | | |
|--|---|--|
| <p>1</p>  <p>WOOD DOWEL QTY 20</p> | <p>2</p>  <p>CAM BOLT QTY 14</p> | <p>3</p>  <p>CAM LOCK QTY 4</p> |
| <p>4</p>  <p>CAM LOCK QTY 10</p> | <p>5</p>  <p>SCREW QTY 18</p> | <p>6</p>  <p>SCREW QTY 4</p> |
| <p>7</p>  <p>METAL HINGE QTY 4</p> | <p>8</p>  <p>MAGNET QTY 2</p> | <p>9</p>  <p>METAL PLATE QTY 2</p> |
| <p>10</p>  <p>SCREW QTY 2</p> | <p>11</p>  <p>HANDLE QTY 2</p> | <p>12</p>  <p>SCREW QTY 2</p> |
| <p>13</p>  <p>SCREW QTY 2</p> | <p>14</p>  <p>SHELF SUPPORT QTY 8</p> | <p>15</p>  <p>SCREW QTY 2</p> |
| <p>16</p>  <p>PLASTIC ANCHOR QTY 2</p> | <p>17</p>  <p>CAP QTY 6</p> | |

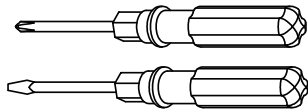

Required -
Flathead screwdriver
Phillips screwdriver
Rubber mallet
Not Included

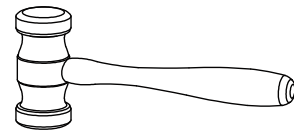

NEED HELP? For help with assembly or if you are missing a part,
Please call customer service

COMPONENTS-KEY DIAGRAM

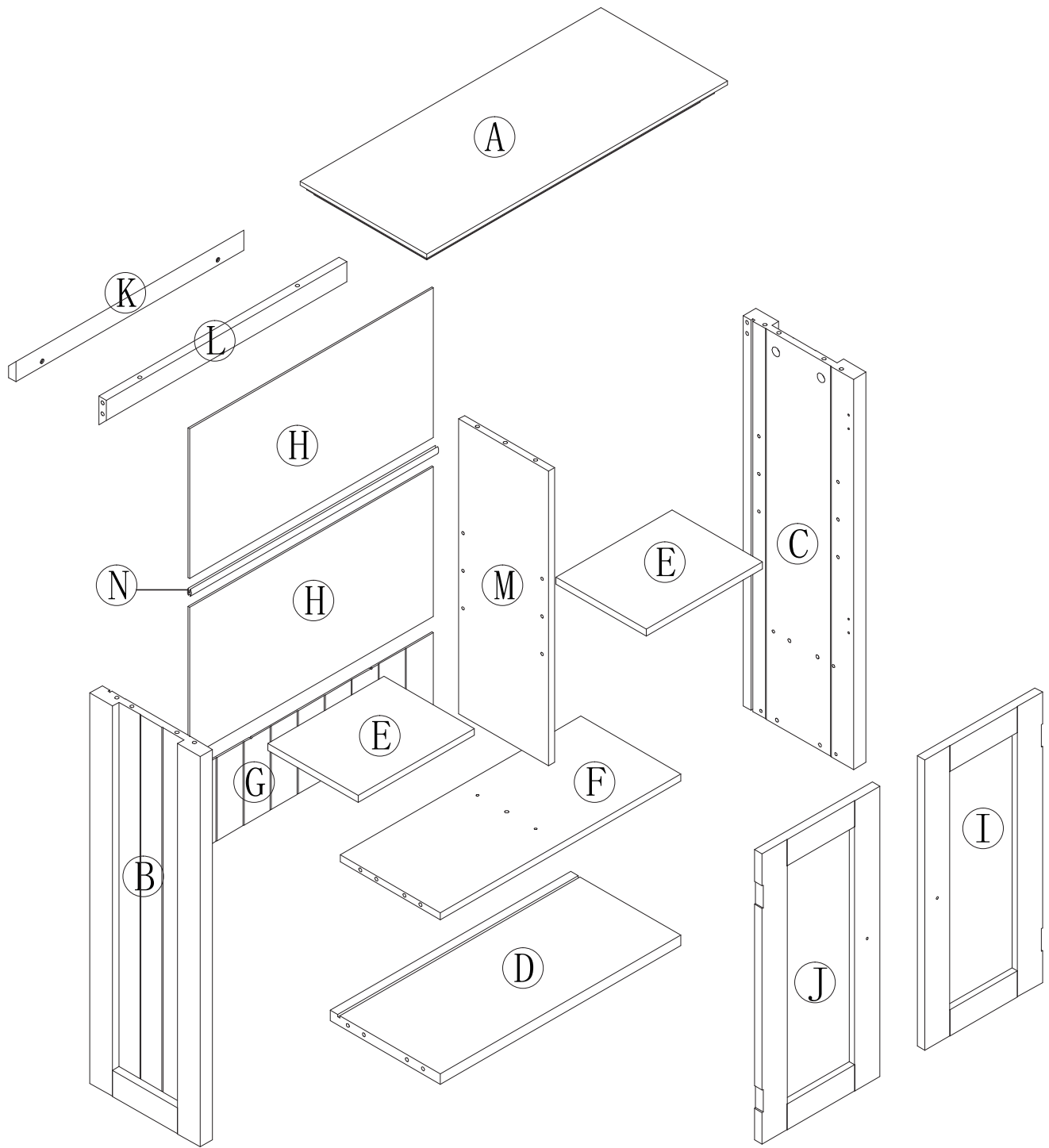

ASSEMBLY

STEP 1

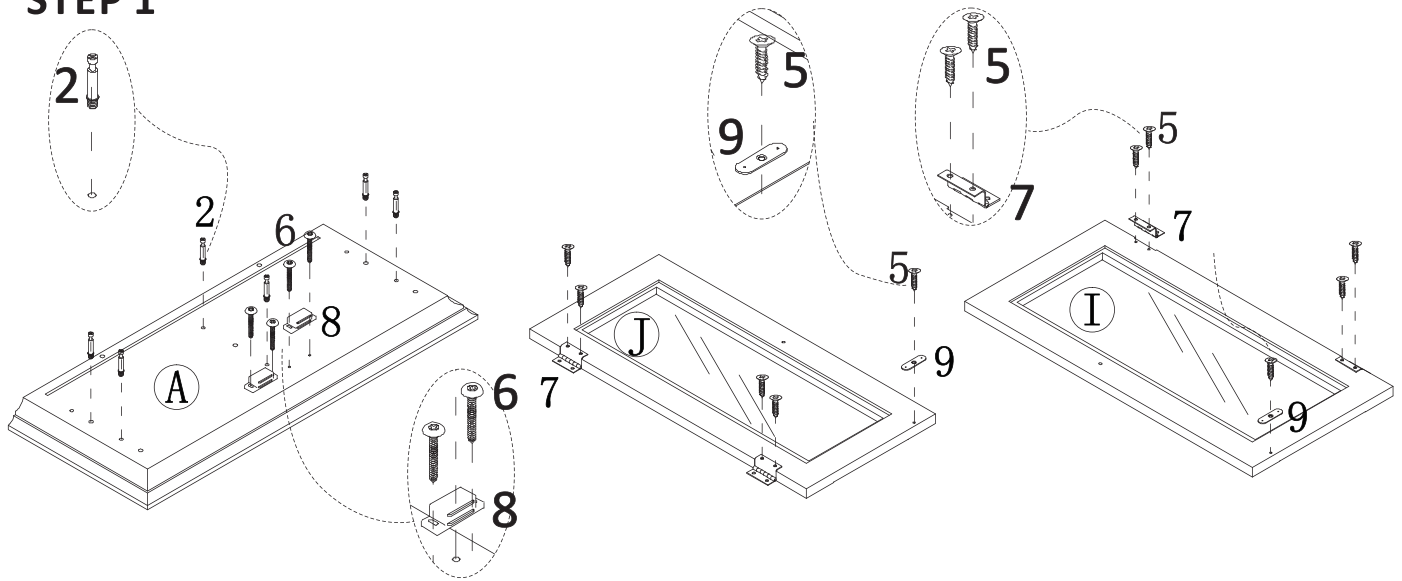

Assembling Cabinet Top, Left Side Door and Right Side Door

1. Lay down the cabinet top (A) and screw six cam bolts (2) into the pre-drilled holes using a Phillips screwdriver.
2. Attach two magnets (8) to the cabinet top (A) by inserting four screws (6) through the holes on the magnets (8) and tighten using a Phillips screwdriver.
3. Lay down the left side door (J) and attach two metal hinges (7) to the door by inserting four screws (5) through the holes on the metal hinge (7) and tighten using a Phillips screwdriver.
4. Attach the metal plate (9) to the door (J) by inserting one screw (5) through the holes on the metal plate (9) and tighten using a Phillips screwdriver.
5. Lay down the right side door (I) and attach two metal hinges (7) to the door by inserting four screws (5) through the holes on the metal hinge (7) and tighten using a Phillips screwdriver.
6. Attach the metal plate (9) to the door (I) by inserting one screw (5) through the holes on the metal plate (9) and tighten using a Phillips screwdriver.

STEP 2

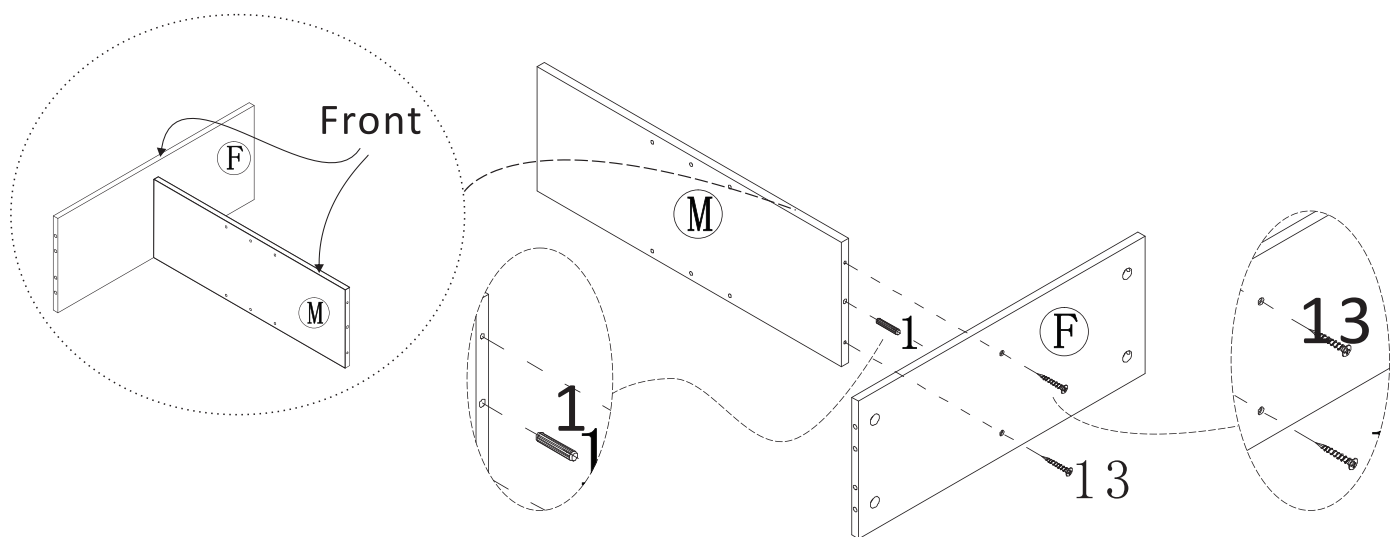

Assembling Middle Shelf and Support Plate (Divider)

1. Attach support plate (M) to the middle shelf (F) by inserting one wood dowel (1) into dowel hole on support plate (M) and the middle shelf (F).
2. Insert two screws (13) through the holes on the middle shelf (F) and tighten using a Phillips screwdriver.

ASSEMBLY

STEP 3

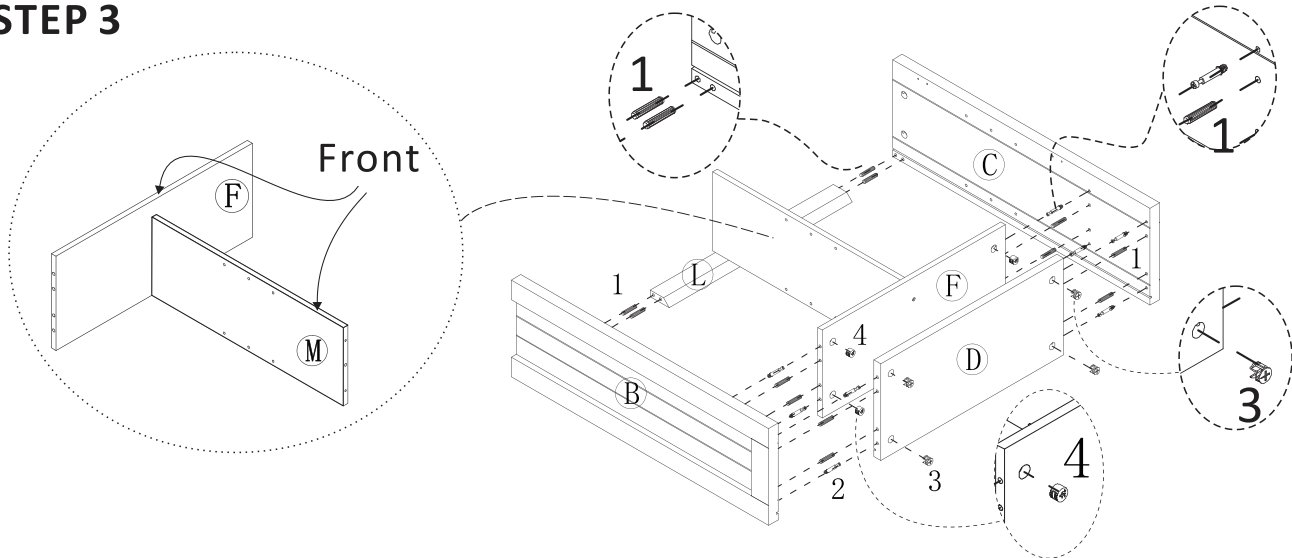

Assembling the Left Side Panel, Right Side Panel, Middle Shelf, Bottom Panel and Rear Top Cross Bar

1. Lay down the left side panel (B) and screw four cam bolts (2) into pre-drilled holes using a Phillips screwdriver.
2. Lay down the right side panel (C) and screw four cam bolts (2) into pre-drilled holes using a Phillips screwdriver.
3. Attach the middle shelf (F), bottom panel (D) and rear top cross bar (L) to the left side panel (B) by inserting six wood dowels (1) into the dowel holes on the left side panel (B), middle shelf (F), bottom panel (D) and rear top cross bar (L).
4. Insert two cam locks (4) into the cam lock holes on the middle shelf (F) and insert two cam locks (3) into the cam lock holes on the bottom panel (D), and rotate clockwise to secure cam bolts are in place using a Phillips screwdriver.
5. Attach the middle shelf (F), bottom panel (D) and rear top cross bar (L) to the right side panel (C) by inserting six wood dowels (1) into the dowel holes on the left side panel (B), middle shelf (F), bottom panel (D) and rear top cross bar (L).
6. Insert two cam locks (4) into the cam lock holes on the middle shelf (F) and insert two cam locks (3) into the cam lock holes on the bottom panel (D), and rotate clockwise to secure cam bolts are in place using a Phillips screwdriver.

STEP 4

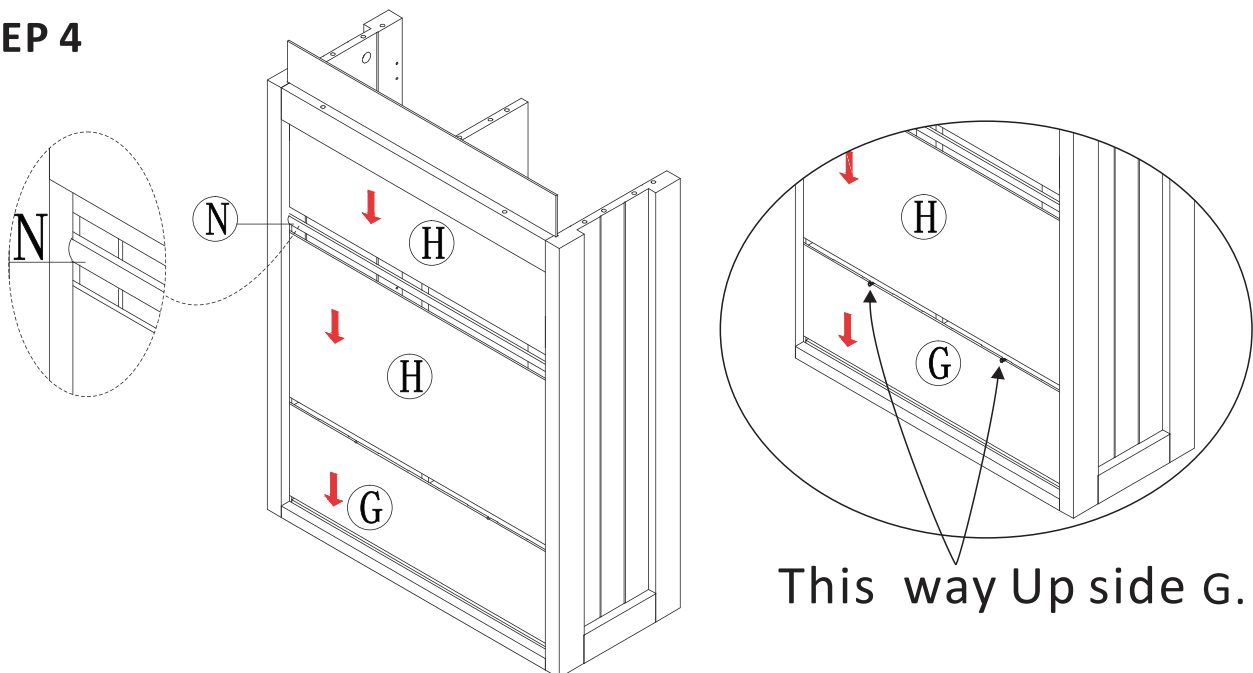

Assembling the Top Back Panel and Bottom Back Panel

1. Insert the bottom back panel (G) into the groove of left side panel (B) and right side panel (C).
2. Insert the one top back panel (H) into the slot of left side panel (B) and right side panel (C). Connect the other top back panel (H) with the panel connector (N).

ASSEMBLY

STEP 5

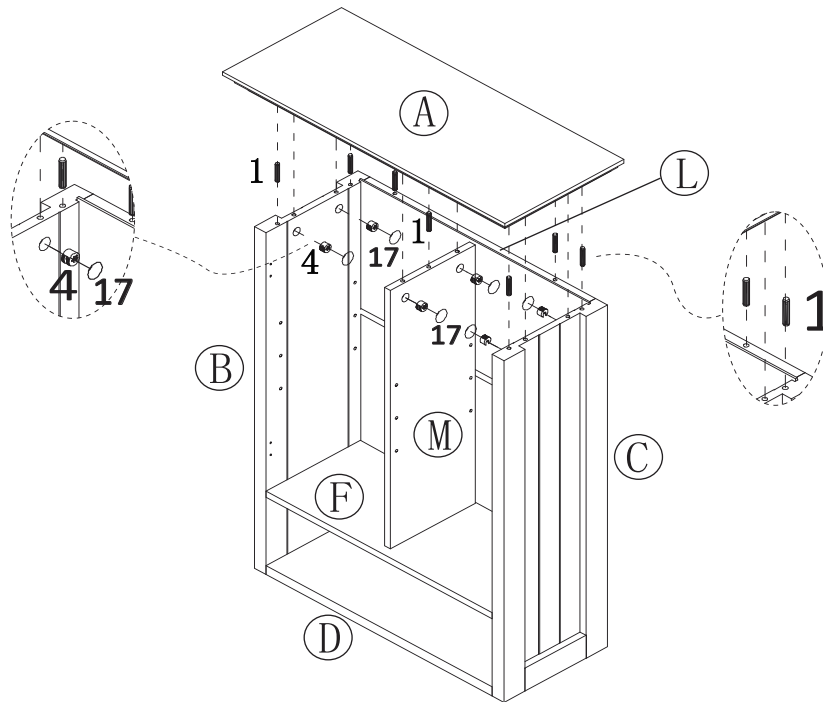

Assembling Cabinet Top

1. Attach the cabinet top (A) to both pre-assembled left side panel (B) and right side panel (C) and rear top cross bar (L) and support plate (M) by inserting seven wood dowels (1) into the dowel holes on both tops of left side panel (B) and right side panel (C) and rear top cross bar (L) and support plate (M) .
2. Insert six cam locks (4) into cam lock holes on left side panel (B) and right side panel (C) and rear top cross bar (L) and support plate (M) and rotate clockwise to secure cam bolts in place using a Phillips screwdriver.
3. Cover the cam locks with caps (17) on left side panel (B) and right side panel (C) and support plate (M).

STEP 6

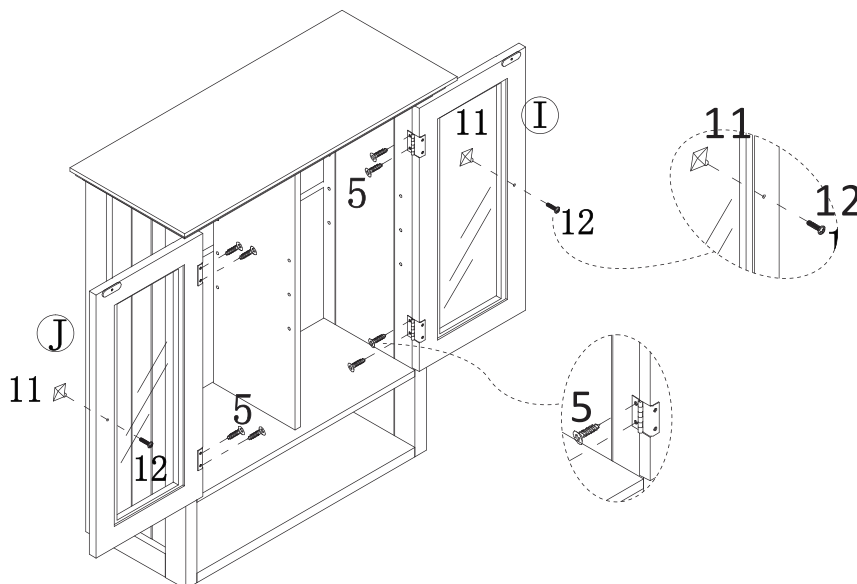

Assembling Left Side Door and Right Side Door

1. Attach the left side door (J) to the left side panel (B) by inserting four screws (5) through the holes on the door hinges and tighten.
2. Attach the right side door (I) to the right side panel (C) by inserting four screws (5) through the holes on the door hinges and tighten.
3. Attach the handles (11) to both doors (I) and (J), by inserting two screws (12) through holes on both doors (I) and (J) and tighten using a Phillips screwdriver.

ASSEMBLY

STEP 7

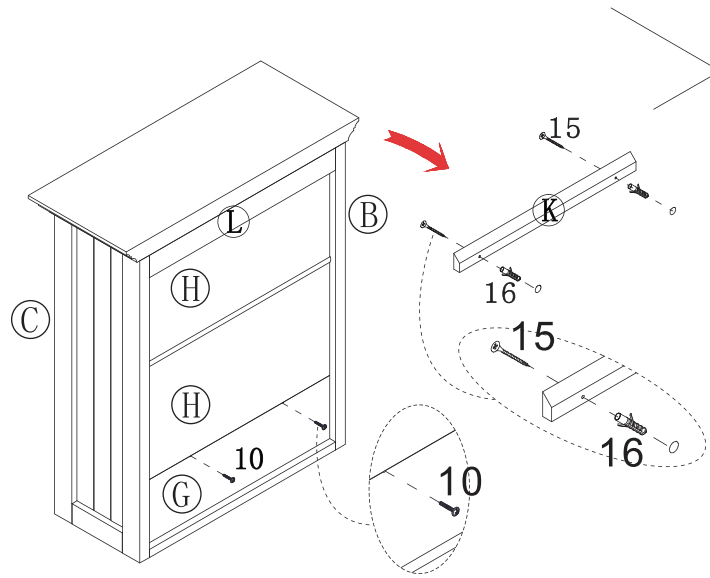

Assembling Rear Bottom Cross Bar

1. Insert two screws (10) into the holes of bottom back panel (G) and top back panel (H) using a Phillips screwdriver.
2. Drill two holes in the wall according height of holes on the rear top cross bar.
3. Insert two plastic anchors (16) into the holes. Using the two screws (15) to lock rear bottom cross bar (K) on the wall.

STEP 8

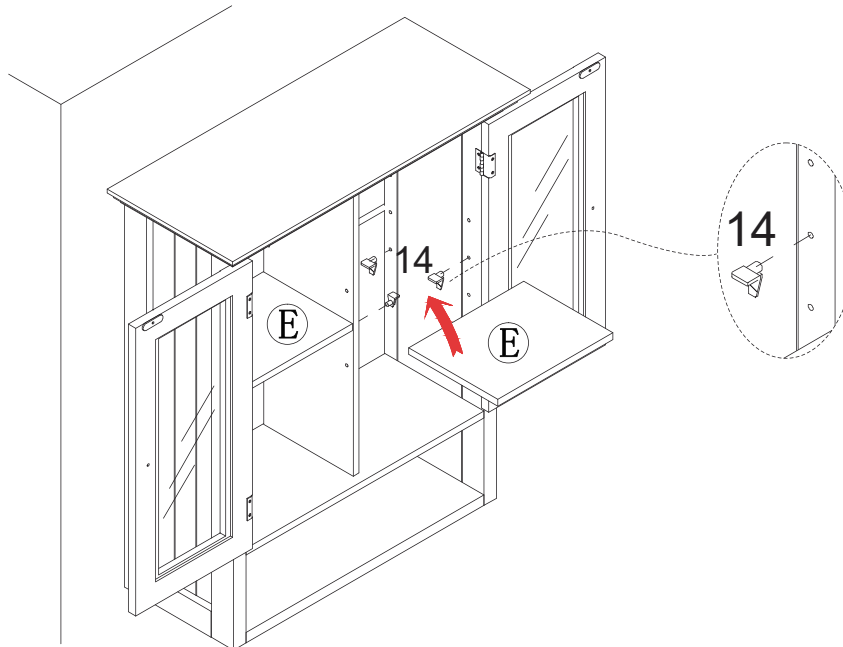

Assembling Adjustable Shelf

1. Insert eight shelf supports (10) into holes in the cabinet on both side panels (B) and (C) and support plate (M) at the same level.
2. Insert the two adjustable shelves (E) into the cabinet on the top of the shelf supports.

WARRANTY

Thank you for purchasing a product. These products have been made to demanding, high-quality standards and are guaranteed for domestic use against manufacturing faults for a period of 12 months from the date of purchase. This warranty does not affect your statutory rights.

In case of any malfunction of your product (failure, missing parts, etc.) please contact us at our toll free service line or by email

We reserve the right to repair or replace the defective product, at its discretion.

This product is guaranteed for 12 months if used for normal purposes. Any warranty is invalid if the product has been overloaded or subject to neglect, improper use or an attempted repair by other than an authorized agent. Heavy-duty or daily professional/commercial usage are not guaranteed.

Due to continuous product improvement, we reserve the right to change the product specifications without prior notice.